



This is a digital copy of a book that was preserved for generations on library shelves before it was carefully scanned by Google as part of a project to make the world's books discoverable online.

It has survived long enough for the copyright to expire and the book to enter the public domain. A public domain book is one that was never subject to copyright or whose legal copyright term has expired. Whether a book is in the public domain may vary country to country. Public domain books are our gateways to the past, representing a wealth of history, culture and knowledge that's often difficult to discover.

Marks, notations and other marginalia present in the original volume will appear in this file - a reminder of this book's long journey from the publisher to a library and finally to you.

Usage guidelines

Google is proud to partner with libraries to digitize public domain materials and make them widely accessible. Public domain books belong to the public and we are merely their custodians. Nevertheless, this work is expensive, so in order to keep providing this resource, we have taken steps to prevent abuse by commercial parties, including placing technical restrictions on automated querying.

We also ask that you:

- + *Make non-commercial use of the files* We designed Google Book Search for use by individuals, and we request that you use these files for personal, non-commercial purposes.
- + *Refrain from automated querying* Do not send automated queries of any sort to Google's system: If you are conducting research on machine translation, optical character recognition or other areas where access to a large amount of text is helpful, please contact us. We encourage the use of public domain materials for these purposes and may be able to help.
- + *Maintain attribution* The Google "watermark" you see on each file is essential for informing people about this project and helping them find additional materials through Google Book Search. Please do not remove it.
- + *Keep it legal* Whatever your use, remember that you are responsible for ensuring that what you are doing is legal. Do not assume that just because we believe a book is in the public domain for users in the United States, that the work is also in the public domain for users in other countries. Whether a book is still in copyright varies from country to country, and we can't offer guidance on whether any specific use of any specific book is allowed. Please do not assume that a book's appearance in Google Book Search means it can be used in any manner anywhere in the world. Copyright infringement liability can be quite severe.

About Google Book Search

Google's mission is to organize the world's information and to make it universally accessible and useful. Google Book Search helps readers discover the world's books while helping authors and publishers reach new audiences. You can search through the full text of this book on the web at <http://books.google.com/>

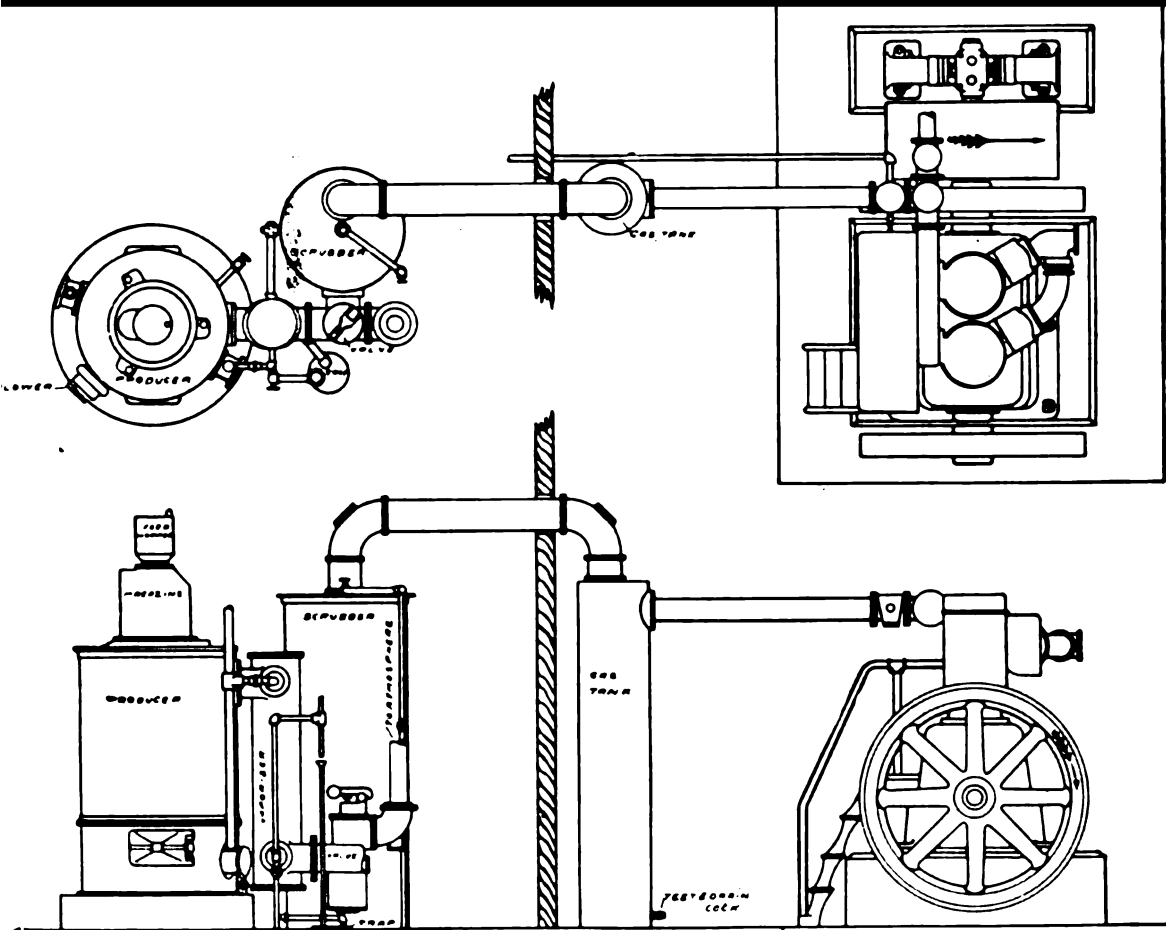

Gas engine

317528

NEW YORK PUBLIC LIBRARY

BEAU DE ROCHAS 1862

CLEVE

BRADY

HUGHES

BARSANTI

MATHEVILLE

MEYERS

ATHURSON

OTTO

LEBON

TRACY

LEBON

LEBON

LEBON

LEBON

LEBON

LEBON

LEBON

LEBON

LEBON

LEBON

LEBON

LEBON

LEBON

LEBON

LEBON

LEBON

LEBON

LEBON

LEBON

LEBON

LEBON

LEBON

LEBON

LEBON

LEBON

LEBON

LEBON

LEBON

THE GAS ENGINE

A MONTHLY MAGAZINE

Devoted to the interests of the
GAS-ENGINE INDUSTRY
STATIONARY · AUTOMOBILE · MARINE
JANUARY, 1905

CONTENTS

EDITORIAL	1
THE COST OF NATURAL GAS OPERATION	2
MODERN TWO-CYCLE VS. FOUR-CYCLE GAS EN- GINE PLANTS	4
GAS ENGINE SPECIFICATIONS	8
GAS ENGINE THEORY AND PRACTICE	9
LAYING TELEPHONE CABLES	13
THE MARINE OIL ENGINE	14
WOOD GAS FOR GAS ENGINES	17
A SUCCESSFUL MOTOR CANOE	18
THE EFFICIENCY OF THE GAS TURBINE	19
INTERNAL COMBUSTION ENGINES AT KEY WEST	21
ALTERNATING CURRENT ELECTRIC TRACTION	21
AUTOMOBILE DEPARTMENT	22
A BRITISH AGRICULTURAL MOTOR	23
AN ENGLISH VIEW OF AIR-COOLING FOR MOTOR CAR ENGINES	25
MOTOR BOAT PAPERS	27
THE COMMERCIAL MOTOR CAR PROBLEM	28
WILE GAS PRODUCER	29
GASOLINE ENGINES IN NEW ORLEANS	31
THE "B & C" FRICTION CLUTCH PULLEY	32
TRADE PUBLICATIONS	33
INDUSTRIAL ITEMS	34

Vol. VII

PUBLISHED BY
THE GAS ENGINE PUBLISHING CO.
CINCINNATI · OHIO

No. 1

VFA



Edison Primary Batteries

Formerly
EDISON-LALANDE

These batteries are extremely simple in construction; the battery consisting of a copper oxide plate contained by two grooved copper supports, which are bolted together by a copper bolt at the bottom of the oxide plates, and two zinc plates, the whole being suspended from the cover.

The liquid is a solution of high-grade caustic soda on which is floated a layer of oil to prevent evaporation and to avoid creeping.

Completely described in catalogue No. 4. Send for it.

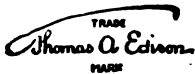

New York, 83 Chambers St.

EDISON MFG. CO.

Factory, Orange, N. J.

Chicago, 304 Wabash Ave.

Gordon Battery

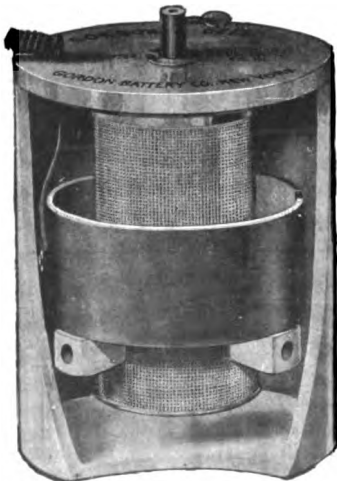

For IGNITION.

Easy to handle
and easy to re-charge.

Only one connection to unfasten and the whole cell can be taken apart.

Guaranteed long life and efficiency.

ASK FOR CATALOGUE.

GORDON BATTERY CO.,

439-445 East 144th St.,

NEW YORK, N. Y.

Index to Advertisers

Buyers' Guide, page 10

For Sale and Wants, page 13

Altemus, C. L. & Co. -	9
Binsse Machine Co., The -	8
Boker, Hermann & Co. - - - -	2
Bullock-Beresford Mfg. Co. The	4th Cover
Byrne, Kingston & Co. - - - -	6
Carlisle & Finch Co. - - - -	7
Columbus Machine Co. - - - -	2
Dayton Electrical Mfg Co. - - - -	8
Draftsman, The - - - -	2
Dyke, A. L. - - - -	9
Edison Mfg Co. - - - -	2nd Cover
Fischer Special Mfg. Co. - - - -	9
Fort Wayne Foundry & Machine Co. -	7
Gillespie, L. W. & Co. - - - -	9
Gordon Battery Co. - - - -	2nd Cover
Hardy, R. E. Co. - - - -	9
Induction Coil Co., The - - - -	9
International Power Vehicle Co. - - -	7
Jacobson Machine Mfg Co. - - - -	8
Johns-Manville Co., H. W. - - - -	4
National Coil Co. - - - -	1
Neustadt Co., J. H. - - - -	9
New Era Gas Engine Co. - - - -	9
Obermayer Co., S. - - - -	7
Olds Gasoline Engine Works - - - -	1
Patterson, Gottfried & Hunter, Ltd. -	6
Perfection Magneto Co. - - - -	7
Powell, The Wm. Co. - - - -	8
Reliance Mfg. Co. - - - -	5
Remy Electric Co. - - - -	9
Richardson Engineering Co. - - - -	9
Roberts, E. W. - - - -	4th Cover
Roth Bros & Co. - - - -	7
Sargent, C. E. - - - -	7
Temple Pump Co. - - - -	2
Turner Brass Works - - - -	6
Union Drop Forge Co. - - - -	1
Watkins, The Frank M. Mfg. Co. - - -	5
Westinghouse Machine Co., The - - -	1
Wilson, H. B. & Co. - - - -	2

THE GAS ENGINE.

STATIONARY—AUTOMOBILE—MARINE.

PUBLISHED MONTHLY BY

The Gas Engine Publishing Co.

Blymyer Building, Cincinnati, Ohio.

ADVERTISING RATES ON APPLICATION. Address All Communications to the Company.

Entered at the Postoffice at Cincinnati, Ohio, as Second Class Matter Feb. 20, 1899.

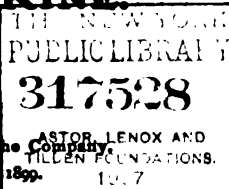

VOL. VII.

JANUARY, 1905.

No. 1

Domestic Subscriptions, \$1.00 per Annum.

Single Copies, 10 cents.

Foreign, \$1.50 per Annum.

A Wisconsin newspaper states that a "double explosion gasoline engine" has been invented. It adds that the "engine is on the same principle as a steam engine."

It is said that a make and break igniter has been used recently on a motor operating at a speed of 3,000 r.p.m., there being no difficulty in securing proper ignition under the conditons.

In this season of anti-freezing mixtures we note that at least one of the automobile companies is advocating a compound which will remain fluid at 10 degrees below zero, will not crystalize, will not injure the metal, etc. An oil that answers the same description, and which has been highly recommended for the use is an ice machine oil, which will stand a very low temperature without congealing—as it is a low cold test oil.

With the assembling of Congress there has arisen considerable agitation of the subject of low-taxed alcohol for industrial uses. There is before Congress a bill, known as the Boutelle free alcohol bill, which we referred last year. This bill, if passed, will provide that alcohol used for manufacturing and industrial arts, shall be free of tax when suitably denaturalized. European nations have all passed such laws, and have accordingly profited by the use of low-priced alcohol for industrial uses.

The Department of Agriculture has reported that untaxed alcohol could be profit-

ably sold in this country for 15 cents per gallon, and several authorities have stated that it could be furnished at as low as 10 cents per gallon. There are thousands of uses to which such alcohol can be put with profit to the people of the United States. Among these is that of fuel for internal combustion engines. In view of the increasing price of gasoline during the last five years, the ultimate probability of our having to use some other liquid fuel has frequently been under discussion by those interested. Alcohol offers at least a partial solution, but in order to be cheap enough for this use it must be freed from the tax at present placed upon it. We hope that the Boutelle bill will be passed at the present session of Congress, and its passage is not at all unlikely in view of the efforts that are being put forth in the matter.

One hundred persons in an Indiana town recently petitioned the Town Council to pass an ordinance prohibiting the installation of a gas engine within "hearing distance" of a residence in the town. Later the Council appropriated \$20, which was placed at the disposal of a committee to "investigate and experiment and ascertain the proper method of procedure necessary to muzzle the exhaust from gas engines." This town is in the midst of the Indiana oil fields, and we are surprised that the Council and 100 citizens of the town should be so far behind the times as to find it necessary to appropriate \$20 to learn how to muffle a gas engine properly.

THE COST OF NATURAL GAS OPERATION.

By ALBERT STRITMATTER

The prospective user of a gas or gasoline engine naturally desires to know in advance about what it will cost him for fuel to operate his engine. He is usually told that on gasoline it will not exceed a gallon per H. P. per ten hours, on natural gas it will not exceed about 15 cu. ft. per H. P. per hour, and on artificial gas about 20 to 22 cu. ft. per H. P. per hour. These apply to engines on full load, and on less than this there is a gradual increase in consumption per H. P. as the load decreases below the full load.

It is not always possible to secure infor-

haust is used, which permits part of the burned gases to escape through this port, instead of the exhaust valve. The engine takes in a fresh charge of air, when cutting out charges, thereby scavenging the cylinder instead of sucking back exhausted gases as is the case with nonscavenging engines. Electric and tube ignition are supplied on the engine, but the writer has not data as to whether the latter was used on any of the engines in question. Natural gas, costing 25 cents per thousand cubic feet, was used for fuel.

H. P. of Engine, Inc	6 to 10	12 to 20	22 to 30	35 to 40	45 to 50	60	80	Total
No. of Engine	14*	7†	13‡	12,	6	3	2	57
Total H. P.	114	116	344	455	296	180	160	1664
Totals hours run, per day	94	52	130	103	62	36	30	487
Total cost for gas, per mo.	\$46 50	\$30 75	\$181 00	\$188 90	\$132 25	\$63 25	\$66 00	\$708 75
Average H. P.	8.14	16.57	26.45	37.91	49.16	60	80	29.2
Average hours per day	6.7	7.4	10	8.6	10.3	8.7	10	8.56
Average monthly cost per H. P.	40.79c	26.50c	52.61c	41.52c	44.86c	35.14c	41.25c	42.60

*One engine ran but one hour per day, and two but two hours.
†One engine ran but five hours per day.

‡One engine ran but two hours per day, and one but four hours.
§One engine ran but two hours and one but one and a half hrs.

mation as to the cost of operation of engines under actual conditions of installation. That is, the prospective customer may feel that the cost of operation when under the supervision of experts is not as much as it will likely be under his own less expert care.

The engines, the cost for fuel for which is given herewith, were not in the hands of experts. It is not known exactly what power they were developing, for they are rated at the power at which they are sold. It is not known just how many hours each day each one operated, but this is known very closely, as it was known in each case what the working hours of each plant were. It is not claimed that the figures are any indication of what may be done under expert service, but that they are the actual figures secured from engines installed and running under ordinary conditions.

First, as to the engines themselves. They were all of the four-cycle type, governing on the hit and miss plan. An auxiliary ex-

These figures show a cost per H. P. per month so low that no engine manufacturer would guarantee them. Assume a guaranteed fuel consumption of not to exceed 15 cubic feet of natural gas per H. P. per hour. This would mean 150 cubic feet per day of 10 hours, or 3,900 cubic feet per H. P. per month of 26 days. At 25 cents per thousand cubic feet this would mean 97.5 cents per H. P. per month, which is the guaranteed maximum rate on full load.

The figures given in the accompanying table show about half this guaranteed maximum rate. We must assume that the figures are correct, for the engine manufacturer, as well as the users of the engines, stand back of them. The low cost must, therefore, be due to the fact that the engines were running on less than full load, which is as should be.

But there was considerable difference between the various engines of the same size. For instance, one 40 H. P. engine cost

\$13.50, another \$20 and another \$30, while one of the 80 H. P. cost \$30 and the other \$36. This was largely due, no doubt, to the difference in actual load carried by the engines, for each of those just mentioned ran 10 hours per day.

The value of these figures lies, not in their statement of actual costs in any individual case, but in showing that under ordinary cases there should be a much less fuel

bill than would be indicated by the maximum amount which the engine makers are willing to guarantee. In this case 57 engines, aggregating 1,664 H. P., are considered, and the average among them should be worthy of consideration. Is it any wonder that manufacturers of gas engines advertise that the engines will pay for themselves in a year or a year and a half when operating under such conditons?

PEAT GAS FOR GAS ENGINES.

The superior inherent economy of the gas engine over the steam engine, and the prevalence of peat deposits in the Austro-Hungarian Empire, have naturally turned the attention of Austrian technical men to the possibility of employing gas made from peat as a fuel for gas motors. So far as the production of gas from peat is concerned, the chief difficulties lie in avoiding the formation of tar and in achieving economical working. According to Herr E. Hubendick, who discussed the matter recently in the Austrian *Metallurgical Journal*, if tar is formed, it has to be separated, with consequent loss of heating power and complication of the plant. On the other hand, if gas is made without tar, it is difficult to attain a sufficiently good working duty in the generator. A Deutz plant at Goldenburg has shown a consumption per H.P. hour of 2.8 pounds of cut peat containing 16.5 per cent of water. With a Koerting generator for peat fuel, it has been found that the consumption varies per H.P. hour from 6.2 to 1.65 pounds, according as the calorific power of the peat changes from 2250 to 9000 B.T.U. per pound. The calorific value of moor peat is 7740 B.T.U. per pound, of meadow peat 9000, and of bog peat 8460 in the anhydrous state, or with 25 per cent of moisture present, 5525, 6480 and 6065 B.T.U. per pound respectively. Average

peat of a calorific power of 6300 B.T.U. per pound shows a 50 per cent greater cost for the development of power when used as solid fuel to generate steam than when gasefied for use in the gas engine. As to whether peat gas can compete with semi-water gas, anthracite, or coke, the author considers this a question of locality. On the Austrian sea board, anthracite is the most suitable fuel; but in the interior peat gas is the cheapest source of power. The cost of installation is about the same for steam or gas power; but the maintenance charges are lower with gas engines than with steam engines. Gas which will serve for motor use can be made without difficulty from peat, and the generator may be used when convenient for other fuel.

The gasoline engine has been put to many varied uses, and has made possible many outfits (especially in portable service) that would never have been built except with a gasoline engine to deliver power. A New York construction company has built a portable cable hauling device which enables the telephone company to draw in 5,000 feet of cable daily, a task which formerly required nine men for three days. The device consists of a 7 H.P. gasoline engine mounted on a specially constructed wagon with the necessary friction clutches, drums, etc.

MODERN TWO-CYCLE VS. FOUR-CYCLE GAS ENGINE PLANTS.

By FRANK C. PERKINS

It is now generally conceded that the four-cycle double-acting gas engine has the same advantages over the single-acting four-cycle internal combustion engine as the double-acting steam engine has over the single-acting steam engine. Until recently high-power gas engine engineers were not in favor of using stuffing boxes, and this, without doubt, retarded the development of the double-acting gas engine of both the two-cycle and the four-cycle types. The modern high-power gas engine of the two-cycle, as well as the four-cycle types, are now beyond the experimental stage, being designed with efficient stuffing boxes proper lubricating systems and efficient cooling arrangements for the pistons, valves and cylinders.

The Koerting two-cycle engine repre-

sents one of the best constructions of this type for large powers, is highly efficient and is claimed by prominent engineers to possess many advantages over the double-acting four-cycle engines. The confidence of eminent American engineers in two-cycle gas engines of large powers is demonstrated by the fact that the largest steel plant power houses in the world at Buffalo, N. Y., are being equipped with these engines by the Delavergne Machine Co., of New York, the total capacity being 40,000 H.P.

The largest steel plants in America, as well as in Europe, are now utilizing the blast furnace gases for operating high-power gas engines in the steel plant power houses, not only for generating the necessary current for operating the various electrically driven machine tools, but also for

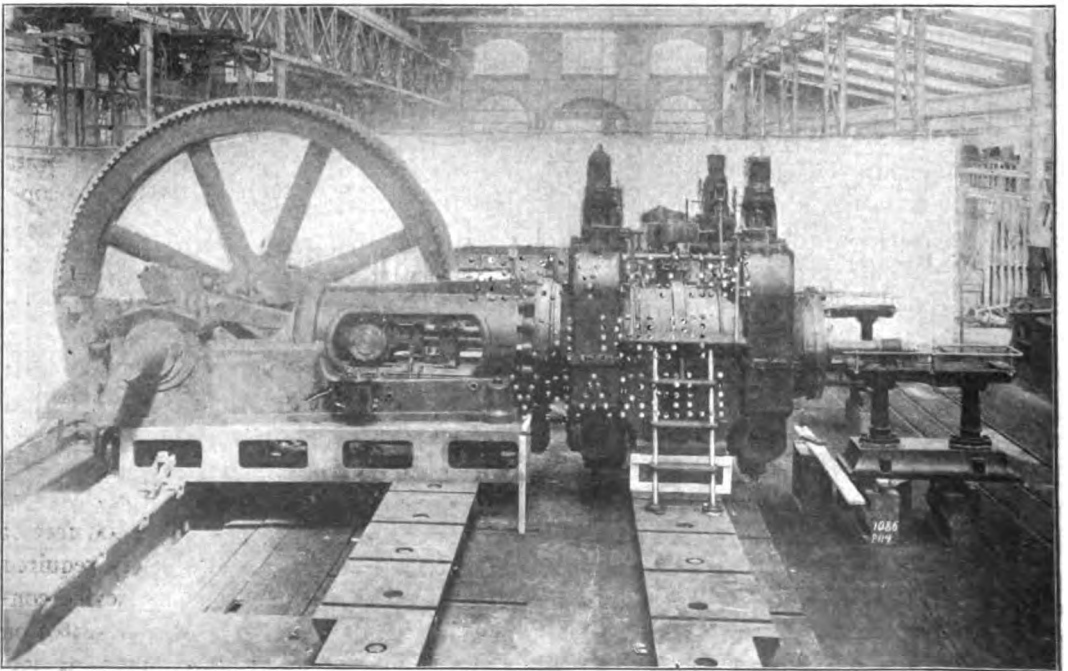

600 Horsepower Four-Cycle Engine.

driving the great blowing engines which until recently were operated by steam engines supplied with steam from boilers which utilized the waste blast furnace gases as a fuel.

At the Lackawanna Steel Works, in Buffalo, N. Y., one power house is being equipped with sixteen 2,000 H.P. gas engines driving blowing engines, while the electric power plant include eight 1,000 H.P. double-acting gas engines of the Koerting type, driving electrical generators of both the alternating and direct current type. Many engineers of prominence are just as strongly in favor of the four-cycle gas engine, claiming this type to be far more satisfactory in every way for large powers. In a comparison between the two-cycle and four-cycle systems, the American engineers constructing the Nurnberg double-acting four-cycle gas engine make the following statement :

“The two-cycle, or Clerk cycle, system possesses features which at first glance ap-

pear to offer numerous advantages. The distribution of effort attained with a cylinder of this cycle, if double-acting, is exactly the same as that attained with a double-acting steam cylinder; consequently to obtain an impulse at every stroke only a single working cylinder of the two-cycle double-acting type is required, as compared with two working cylinders necessitated by the four-cycle double-acting system.

“To attain this two-cycle action the products of combustion must be discharged from the working cylinder and a fresh charge of gas and air admitted to same, during a very small fraction of the time of each stroke; while with the four-cycle system, one full stroke is available for the driving out of the products of the previous combustion and another full stroke for the drawing in of the fresh charge. The air and gas for a two-cycle gas engine must, prior to the opening of the admission valve, be subjected to the pressure necessary to insure their sufficiently rapid expulsion, by them, from the

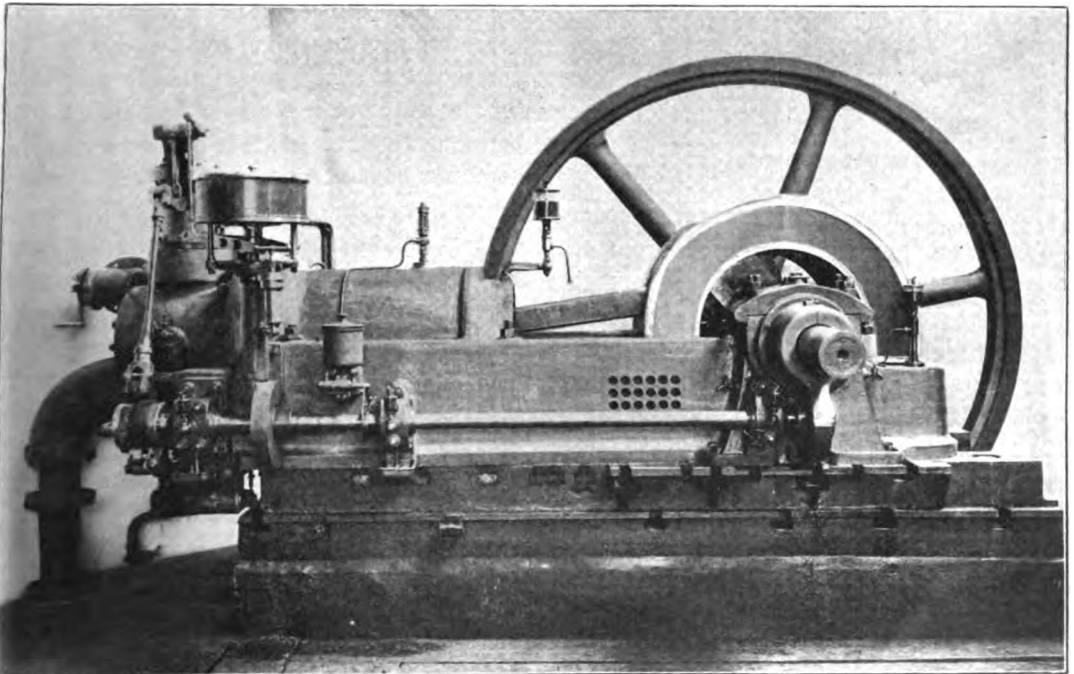

80 Horsepower Four-Cycle Engine.

working cylinder, of the products of the previous combustion. For this purpose it is necessary that, in addition to the working cylinder of the engine there be provided a gas compressing cylinder and an air compressing cylinder each with its piston and driving mechanism, its valves and valve gearing. For the same distribution of power, therefore, the four-cycle double-acting gas engine requires two working cylinders which, in all their details, are exact duplicates one of the other; while the two-cycle double-acting gas engine requires three

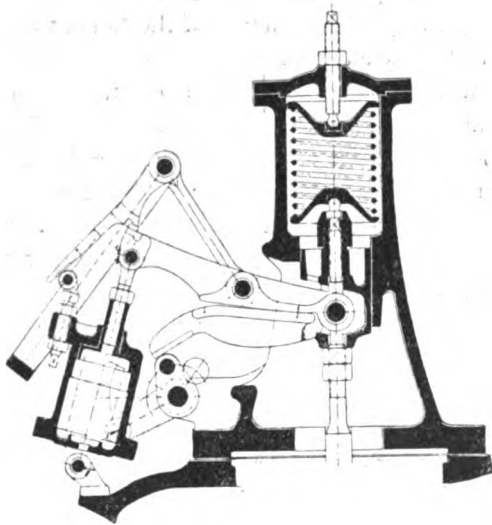

Nurnberg Valve Gear

cylinders, each with its piston, gearing, valves, etc., and each differing from the other two.

“In the compressing cylinders of the two-cycle engine the air and gas are subjected to a pressure of eight to ten pounds per square inch, and as they are admitted into the working cylinder at a moment when this is open to the exhaust and opposes to them no back pressure, other than that due to the friction of the exhausting products of combustion through their passages; the pressure in the inflowing air and gas merely spends itself in velocity, and the power consumed in sub-

them to this pressure is, therefore,

absolutely lost, so far as power development is concerned.

“Careful tests prove that under favorable conditions at normal speed the power consumed by the air and gas compressing cylinders of a modern two-cycle double-acting gas engine amounts to about 13% of the normal indicated power developed in the working cylinder, and that, provided the speed remained constant, this power consumed by the pumps also remained constant, even though the load upon the engine decreased to its minimum. In other words, leaving out of consideration the purely mechanical losses resulting from the friction of the moving parts of the engine, the two-cycle double-acting gas engine to develop 1000 I.H.P. must actually develop in its working cylinder 1130 I.H.P.; the same engine when working at half load, that is, developing 500 I.H.P. must actually develop in its working cylinder 630 I.H.P., this being equivalent to an indicated efficiency of only 79½%. Under lower loads the efficiency of the two-cycle engine would, of course, rapidly decrease still farther. Results slightly better than this have been obtained under conditions especially prepared for the test; but it is also a fact that trials, the correctness of which is beyond question, made on a most modern two-cycle double-acting gas engine under conditions of actual operation have shown a lost power double of that mentioned above. It is true that by the application of somewhat complicated mechanism the I.H.P. absorbed by the gas pump may be somewhat reduced, as the load upon the engine decreases and the quantity of gas to be delivered into the working cylinder diminishes; but as this arrangement would affect only the gas compressing pump and that only at under loads it is very questionable whether the slight increase in efficiency obtained thereby would warrant the complication.

“As compared with the above the dia-

grams from a four-cycle double-acting gas engine show a lost work of from $2\frac{1}{2}$ to 5% of the normal indicated power developed in the working cylinder; thus a four-cycle double-acting gas engine to develop 1000 I.H.P. must develop in its working cylinder 1035 I.H.P.; the same engine when working at half load, that is, developing 500 I.H.P., must develop in its working cylinder 535 I.H.P., this being equivalent to an indicated efficiency of about $93\frac{1}{2}\%$.

"As previously stated, no attention has been paid, in the above calculation, to the

under pressure into the working cylinder of a two-cycle gas engine, at a time when the exhaust passages are open, is very liable to result in the loss of unburned gas through the exhaust ports in the cylinder wall, such loss being entirely impossible in a four-cycle machine into the working cylinder of which the gas is drawn by the working piston itself, and at a time when the exhaust valves are tightly closed.

"Yet another consideration in favor of the four-cycle double-acting system in preference to the two-cycle double-acting system is the greater difficulty of lubricating the cylin-

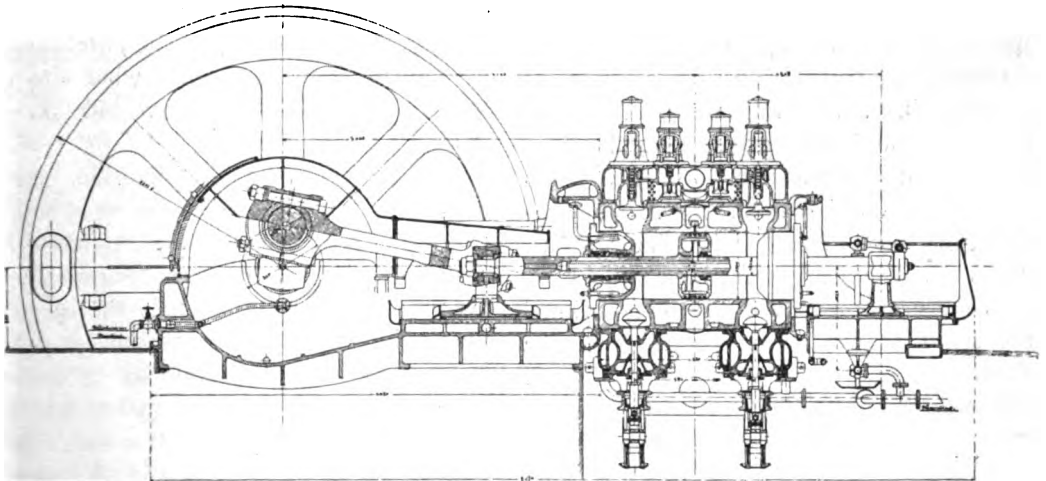

Nurnberg Double-Acting Engine.

purely mechanical efficiency of the engines, so far as it is dependent upon the friction of the moving parts. In engines of both systems the reciprocating parts would be of approximately the same weight and subjected to about the same pressures. The sole difference between engines of the two systems which would affect their mechanical efficiency is, therefore, the difference between the internal friction of the two compressing pumps with their moving parts belonging to the two-cycle machine, as against that of the second working cylinder and it is not to be supposed that the former would be any less than the latter.

"The fact that the gas must be forced

der of the latter machine. The piston of the two-cycle engine, in consequence of its function of exhaust valve, must have a length almost equal to the stroke of the engine, and passes over the exhaust slots in the cylinder wall immediately after these slots have been swept over by the hot exhausting gases, and at its maximum piston speed."

The accompanying illustration shows the double-acting four-cycle engine constructed by the Gas Motoren Fabrik Deutz for the power plant of Fried Krupp for use on blast furnace gases at Essen a.d. Ruhr, while the accompanying drawing shows the details of construction of a Nurnberg engine and valve gear.

GAS ENGINE SPECIFICATIONS.

By A. A. ANDREWS.

Some months ago a gas engine manufacturer was called several hundred miles to figure on a fairly large-sized engine. The bid was to be placed through the architect for the building and specifications had been drawn up covering the entire building and machinery. The engine manufacturer was asked to bid on the engine alone. He asked to see the specifications and on reading them over said at once that he could not submit a bid. When asked why not, he called the attention of the architect to the fact that the specifications called for a vertical engine, throttling governed. The engine he built was a horizontal, hit and miss governed engine. The architect at once recognized the error of the specifications, which were so worded, in addition to the above specifications, that but one make of engine could be received under the specifications.

We recently received elaborate printed specifications from a city engineer in the East, covering a water works plant. About the same class of limitations on the gas engine were made as in the case just referred to. We know of but one make of engine on the market that would answer the description. And yet the engineer thought that in sending out his specifications he was inviting competitive bids. As a matter of fact, but one engine could be supplied if the specifications were adhered to.

More than one architect has admitted under such circumstances that his specifications were copied from a catalogue, and that he did not know how to draw up specifications which would permit of competition, and yet compel all bids to be for the same work. It is intended in this article to bring out some of the points that might be covered in such specifications.

In the first place, unless the purchaser of the engine has determined that he wants

nothing but a certain type of engine, it is unnecessary for him to specify in detail the type. If he will have nothing but a multi-cylinder vertical engine, it is all right to specify it. But if he wishes bids on horizontal engine, he can not secure them by specifying a vertical engine.

Ordinarily an engine manufacturer objects to guaranteeing that his engine "will do the work required," and makes the objection that if he guarantees his engine to deliver so many brake horsepower that is all that should be necessary. The purchaser of the engine should determine what size engine he needs, and then have bids on engines of that power.

Matters such as style of ignition, size of bore, stroke, piston speed, etc., need not be covered in the bid unless the purchaser has some preference. It is often desirable, however, to specify approximately the speed of the driving pulley, or else state that it should be of sufficient speed and size to connect properly to a certain driven pulley, which is to run at a given speed. If connection is made by a clutch or friction clutch pulley it should be so stated.

The location of the engine, tanks, etc., should be specified ordinarily, as the amount of piping, belt, etc., is determined by such locations. Not only this, but certain room is usually set aside for the engine and it is sometimes inconvenient and interferes with other plans not to have this followed out.

Of course, if no water tank is required it should not be specified, but the specifications should call for connecting to city service pipes or whatever provision is made.

There should, of course, be specifications relating to the first-class material and workmanship, as well as such guarantees as to fuel consumption, speed regulation, defective parts, etc., as may be desirable. The main

thing to avoid, however, in justice to all parties concerned, is the specifying of items which are unnecessary or not particularly desired, and which, if prescribed, prevent other types from being entered. The writer has a set of specifications before him in which the diameter of the cylinder walls, the bore and stroke of the cylinders, the shape of the bed, etc., are specified. Under the head of lubrication it is stated that all bearings shall be properly lubricated, and it then goes on to specify exactly where lubricating cups, etc., shall be placed.

The object of specifications, where they are used, is to secure a uniform quality of work and material covered in the estimates. If the competing parties have to guarantee only "to do the work required" one man may figure on a much larger engine than another. To secure bids on the same size engine, the power rating is specified. The specifications, therefore, should cover exactly what is required, but should not make limitations which merely cut out certain engines, unless the purchaser desires not to consider bids on such engines.

GAS ENGINE THEORY AND PRACTICE.

Readers of the *American Machinist* have long been interested and have profited by the articles over the name of W. Osborne. Occasionally he starts out with a statement of apparent truth and leading toward a certain conclusion. Next follows a story which shows how completely wrong was your acquiescent acceptance of the intentionally doubtful statement with which he started out. The regular reader of W. Osborne finally comes to the state of accepting no initial statements, but waiting until the end to see where the argument leads. And as a rule, the conclusions arrived at are sound and sensible.

In a recent talk on gas engines he makes the following remarks:

The theory of the gas engine seems very simple. It is only necessary to draw in a mixture of gas and air, compress it somewhat, explode it, let it expand (doing work while it is expanding), exhaust it and repeat the series. Certainly, certainly. That is very simple; anyone can understand that.

For all of its simplicity it seemed wonderful when finally, after hard and continuous pulling on the flywheels, that first engine did consent to make a few revolutions. There were several wonderful things about

it. It seemed wonderful that it would run at all. It seemed wonderful the way it would refuse to run at all. It seemed wonderful that having started to run nicely it would not run forever if it was not stopped. In looking back it seems wonderful to think of the number of now simple things that we did not know about that engine.

As I held a position where I was to an extent responsible for the making and running of these first oil country gas engines, I can give you at first hand some of the experiences of a *corporal* of industries.

Most mechanics who don't give up and get drunk when things go wrong, try to think of something to do when they get into trouble that will get them out, and I tried to think out that gas engine.

In the first place, there must be some relation between the volumes of gas and of air. They must be gotten into the cylinder. They must be kept in. They must be compressed. They must be ignited. They must be gotten out. This engine ignited with a hot tube, and it must be heated, and kept hot. After some particularly mysterious and vexatious development with the engine, the theory would be gone over and over, but I always seemed to get back to the same

place, and then I would try to think which of these conditions it was that I was not filling.

One of the most common offenses of this new prime mover was its habit of stopping. Sometimes it stopped from one cause and sometimes from another, and very, very often it seemed to stop from just no cause at all. And in starting it seemed to be as unreasonable, for sometimes it would start at the first trial, and sometimes hours of effort did not get it going, nor discover why it would not go. To add to the perplexity it would frequently happen that after every one had been worn out trying to get it started and would go away and leave it for awhile it would start very readily. No amount of reasoning would convince some of the first users of the gas engines in this section that they were not like human beings, with their likes and their dislikes, with their liking for being coaxed, and their dislike for being driven, and indeed the reasoning by which the possession of these qualities was proven was often very logical, in view of the way they behaved.

While it was not very easy to decide why an engine would start up and run one day and positively refuse to do it another, it was not much easier, in those days, to decide why it started for different people who had widely different ways of coaxing it. There were two valves on the engine and one man would tell you that when his engine "balked" he could always start it by taking down the largest of these valves, wiping it off and replacing it. Another man would tell you that the small valve was the one to take down, while still another one would let you into the secret that the oil on the piston head got sort of stale and by pulling the piston head out and cleaning the old oil off and putting on some new the engine would just be glad to run.

Whatever one might think of the reasoning, still the fact remained that some of

these men were able to keep the engines going without much trouble, while others were wearing themselves and us in the shop all out.

One day an elderly man, who was quite badly crippled up, came to the shop. He was running one of the engines and had been quite successful where a much younger and stronger man had failed and abandoned the job. In answer to a query as to whether he ever had any trouble, he replied that he occasionally had, but not very often.

"When you do have trouble what do you do?"

"I go and sit down on a nail keg, and stay there for twenty minutes."

That was a remedy that would appeal to lots of men. It was easier than pulling out a head or taking down a valve. I wanted to know all about it. Perhaps it would pay us to furnish a nail keg as part of the outfit of the engine.

"I don't suppose it would be safe to sit on a box, would it?" I ventured. "If you should move around on the lease, do you suppose the engine would mind it much?"

"I happened to have the nail keg to sit on, and if I go out on the lease I am apt to get busy about something and stay much longer than the twenty minutes, and after all of my experimenting that is about the least time that it takes her to get over one of her fits. I have to handle her just right to have her do it in that time."

Here was a man worth learning from, and I kept him going and found that he pulled the wheels around to a certain position.

"There is one thing certain. When she gets mad about something and stops before I stop her, I will have to do a job of petting and coaxing before I can do anything with her. Just like a woman for all the world. She never refuses to start in the morning when I first start up."

These three things, being hard to start after having stopped, being moved to a cer-

tain position, letting stand for twenty minutes, let some light into my head, and after the man had gone I went down to an engine that was running on the testing block and turned off the gas gradually until it shut down. Calling some help, we tried to start it without success. Moving it to the described position (which was with the exhaust valve wide open) it was left for some time. At the next trial it started without trouble.

It was then shut down in the same way as it had been before, and with the gas shut tightly off it was moved back and forth several times, and then it was tried again and started without trouble. The experiment was tried several times, always with success, and the mystery was solved.

How simple it is now that we know all about it, and what a lot of backaches and

profanity was scattered around before we found out, and all because we did not know that the cylinder was full of gas while we needed gas and air to get an explosion.

It will be readily seen that when an engine is stopped by turning the gas off it makes several revolutions before coming to a stop and during this time it is drawing in air alone. When the gas is turned on to start, it is diluted with the air already in the cylinder, as well as by the air being drawn in with it. When there is gas in the cylinder instead of air, it is not much wonder that things don't go.

A man may have a cylinder full of air to start with, but by not getting the gas adjusted right he may pull in several charges and not get started, and by this means get a mixture too rich to ignite, and the remedy is the same.

ELECTRIC LIGHT OUTFITS.

The Richardson Engineering Company, Hartford, Conn., are making a specialty of gas engine driven electric light plants in small units.

As is well known, the proportionate cost of fuel and labor for operating a plant is much greater during the hours when less power is required than during the time when the demand for power nearly equals the capacity of the plant. In other words, the cost of fuel and labor is much less for furnishing a certain amount of power during twenty-four hours if the plant can be run on a nearly constant load to its full capacity for twelve hours, and then be shut down, than is the case where the full capacity is demanded for only a few hours each day, but the plant has to be kept in operation during the entire twenty-four hours, much of the time on a light and widely fluctuating load. In order carefully proportioned to the generator set.

The motive power can be used at various

times when the electric light plant is not in service, for refrigeration, for pumping water, sawing wood, churning, grinding corn, cutting fodder and operating other forms of machinery. At many times it will

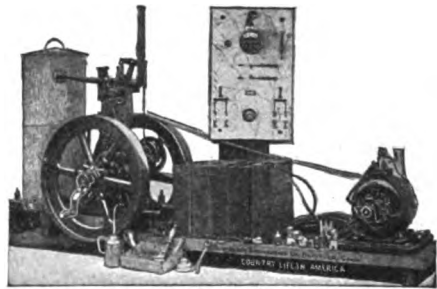

be found a great convenience in many isolated places to have a small refrigerating plant, making one independent of a remote ice supply. A pump outfit will also prove economical and to accomplish the above results, there is included a storage battery

to make these outfits still more practical and a great value to many, both for water supply for the house and for the purpose of sprinkling the lawns directly from the pump and for fire purposes. In most out of town places where more or less wood sawing is to be done, the power is very profitable and a great labor saver.

Quite a number of good sized plants are furnished, the one shown herewith being a 20-light outfit.

The complete outfit consists of the following: a 2 H. P. vertical gas or gasoline engine, floor space set up with generator, 2 x 9 x 4 feet high; shipping weight, 1,600 pounds including generator, a suitable generator with belt; marble switchboard with voltmeter and ammeter, circuit breaker, end cell switch; pilot light; all necessary switches with fuses, etc.; 10 cells of 80 amp. hour

storage batteries; 20 incandescent lamps. any candle power desired, 8 and 16 c. p. generally furnished; fixtures consisting of clusters, brackets, plain receptacles, drop lights, etc., all necessary wire, cleats, rosettes, screws, tape, etc., for ordinary sized house and full directions and plans for setting up and operating.

This outfit will light five 16 c. p. lamps for eight hours or seven lamps for five hours on one charge of the batteries.

The manufacturers will supply these outfits with or without the engines. Inasmuch as they are making a specialty of this class of outfit, the makers claim that they are able to determine exactly what is needed for this class of service, and furnish it without endeavoring to supply a cheap, poorly constructed outfit. Complete instructions are furnished with the plants.

THE JACOBSON GAS ENGINE.

This engine has a number of very valuable features in design to suit the American conditions. In the first place, these engines are all designed with removable cylinder bushings. In case an engine has to be put in to run on natural gas, which, of course, is very rich, it will give more H. P. than when running on lighter gases, such as producer gas, suction gas or blast furnace gas. This has been a good deal of drawback in selling larger units in the natural gas field, where there has been a question as to how long the natural gas would last, and where these engines have afterwards given only from about 70 to 75 per cent of the rated H. P. on producer gas in case of the failure of the natural gas.

With this new improved engine, there is a new scavenging system that will clear the compression space in the engine as a standard, and it will then run equally as well on producer gas in case the natural gas gives

*. With the removable cylinder bushing

system mentioned above, a larger cylinder may be substituted for the natural gas cylinder, and with this increased cylinder diameter, the engine can be arranged to obtain the same amount of H. P. as its initial rating. The engine is worked on the graduated charge system, but has one additional feature that, when the load becomes so light that there is not a large enough filling for the proper compression, and therefore it is doubtful whether or not the charge will ignite, the gas is cut off entirely, and just gives enough air into the cylinder to release the vacuum that there would otherwise be in a common throttling engine, and in that way there is obtained higher efficiency in the fuel consumption than by any other system. These new features can be used in engines up to any size and for any purpose where a gas engine is adopted.

The engine is built in units from 6 to 200 H. P. by the Jacobson Machine Manufacturing Company, Warren, Pa.

LAYING TELEPHONE CABLES.

The American Telephone Journal recently described a system used in laying telephone cables.

The apparatus consists of a 6 H. P. vertical gasoline engine, direct connected to a geared winding drum, actuated by a friction clutch. Both devices are mounted on one base. This makes a compact and self-contained machine, which is mounted on an ordinary platform wagon. This wagon carries a gasoline supply tank and a small water tank for cooling the engine, together

Frank B. Hall, in 7 hours and 40 minutes, 14,719 feet of 200-pair cable were laid by a force of nine men. The best previous record was made in St Louis in 1898 when nine men and a foreman stretched 7,556 feet of 120-pair cable in 8½ hours. Chief Engineer Hall expresses himself as believing that the above described machine is without doubt the best method of stretching cable yet discovered. The 6 H. P. Fairbanks-Morse combined vertical engine and winding gear is provided with a 16-inch drum and a 5-



with the necessary tools and apparatus used in cable laying. The operation of the machine is especially simple, after the engine is put in motion, by turning on the gasoline and pulling the engine over the dead center the engine is kept running continuously, and by means of a friction clutch operated by an end lever the winding drum can be started and stopped at the will of the operator. A small spool or nigger head is located on the outer end of the shaft carrying the winding drum. By means of these two drums it is possible to meet all of the requirements of fast and slow pulling.

This apparatus was recently installed by the Independent Telephone Company at Salt Lake City, Utah, and while in that city a new world's record for laying telephone cable was established by the crew in charge. Under the direction of Chief Engineer

inch winch or nigger head. The wagon upon which the apparatus was mounted was constructed with a 3½-inch running gear, with a heavy bed made of best 6 x 8 Oregon pine. The engine is provided with a regulating device which is arranged so that it can be operated from either side of the running gear, and by means of which the engine speed can be controlled as desired. With a ½-inch wire rope fastened to the end of a large cable, and passed through the subway to the engine, a pull of any distance can be made. As much work has been accomplished by the use of the above described apparatus in five minutes as would have been accomplished formerly by four men in two hours. It would appear that from the description and the records, that an apparatus of this kind would find great favor among many of our larger telephone companies.

THE MARINE OIL ENGINE.

By JOHN F. WENTWORTH

Articles have been written the last few months in which the gas plant, composed of gas engine and a gas producer, has been favored over all kinds of power for marine use. Inasmuch as the producer gas plant is no further advanced toward perfection than the oil engine, it would seem questionable to predict, too certainly, the defeat of the crude oil Otto-cycle engine by the producer gas plant. The writer has made a study of the oil engine for several years, and feels that a few remarks about the apparent merits of different kinds of power, as compared with the oil engine, in the shape that the oil engine is now, may not be out of place.

The producer gas plant on shipboard must use a grade of gas having a heat value of about 150 B. T. U. per cubic foot of gas at 60 degrees F. and atmospheric pressure. This is above the average for producer gas. Illuminating gas has an equivalent of 600 B. T. U. in place of the 150 B. T. U. before stated. However, the richest gas is enough more expensive so that it can not compete with the leaner gas. Owing to the use of the producer-gas, the M. E. P. of the marine gas engine can not be more than 70 pounds. The efficiency of the producer-gas engine is not reduced on account of the comparatively low M. E. P., since the leaner gas allows a pressure of compression of about 170 pounds, against a maximum pressure of compression of 90 pounds with gasoline or illuminating gas. The lower M. E. P. will be a disadvantage only in causing the engine to be more bulky as well as heavier per H. P. Recently some reliable figures on the efficiency of different size producer-gas engines have appeared; they are given below. The figures are not all for the same make of engine, but as those turned out by the leading manufacturers differ only in small features, and not in general principle, and

also since these engines have all the same high-grade workmanship, a comparison of four engines, although of different makes, may be considered a comparison of four engines of the same make.

Make.	B. H. P.	Thermal Efficiency, per cent.
Westinghouse	50	24.6
Crossley	140	26.85
Crossley	400	29
Crossley	400	29
Premier	500	30.38

These figures are based on the brake horse-power and the total energy of the fuel used in the cylinder. For engines of above 500 H. P. per cylinder it appears that the efficiency would be above 30 per cent. The efficiency of the producer on land does not run above 85 per cent, and it is very probable that this figure will not be exceeded on shipboard. This will make the net efficiency of the gas-producer plant about 25 per cent. The temperature of the air and gas in the producer as it is drawn over the incandescent coals must be more than twice the absolute temperature of the atmosphere. This means that for each brake horsepower of the producer-gas engine two cubic feet of gas per minute must be drawn through the hot coals in the process of the formation of the gas. It appears to the writer that it will be necessary to have a bulky apparatus to accommodate such a flow of gas. If it is possible to draw the air through the producer at a high velocity, or perhaps at a pressure above the atmospheric pressure, the bulk of the weight of the producer can be reduced. It would seem, however, that the producer would weigh about as much as the same power steam boiler, in spite of any improvements which may be made to the producer.

In order that the producer-gas plant may

have a fair show against the oil engine, the weight of the producer and its auxiliaries will be taken here to weigh but 75 pounds for an equivalent of the steam I. H. P. This figure is probably about one-half the actual weight.

In considering the crude oil engine there are several very great advantages which it has over the gas engine. The fuel fed to the former engine is rich, and for that reason the M. E. P. will be higher than the M. E. P. of the producer-gas engine. This increase in the M. E. P. should have an effect to decrease the weight per horsepower. Since the fuel is not fed into the cylinder of the engine till it is needed, and pressure of compression can be used in the oil engine from the 500 pounds, which the Diesel uses, to a pressure of 90 pounds or lower, if desired. Theoretically the efficiency of the internal combustion engine should increase with the pressure of compression or inversely with the clearance; however, owing to the upper limit of the ignition pressure, which is obtained in the internal combustion engine, the efficiency would not increase even theoretically beyond a certain point. The actual efficiency of the engine depends upon the indicated efficiency and the mechanical efficiency. It is probable that the mechanical efficiency begins to fall off after the pressure of compression passes 100 pounds. The maximum efficiency of the internal combustion engine should be at about the point corresponding to a compression pressure of 200 pounds. This has not yet been proved to be the point, but will be settled soon, and when settled can be used as the compression pressure for the oil engine, while the gas engine can not exceed a compression pressure of 90 pounds with a rich gas, or 170 pounds with the leaner gas. Owing to the fact that the oil engine can choose its own conditions, it is probable that 35 per cent efficiency is not at all unlikely. For marine work it seems best to have an

engine of the four-cycle, single-acting type, although if this is an error on the part of the writer, it does not affect the oil engine, as it can take any form which is possible to any internal combustion engine.

For an intelligent comparison between the merits of different plants using coal and oil, each fuel should be taken at prices so that the cost per unit of heat available will remain the same. The reason for this is that vessels are now being fitted to burn oil in place of coal. It is probable that the fuel oil is not much more expensive than coal on a basis of the heat units per pound of fuel.

The steamship *Mariposa*, running between San Francisco and Tahiti, was converted into an oil burner over two years ago, and for the comparisons made here the data were obtained for the most part from the report of the Bureau of Steam Engineering, 1902. The price of fuel was not stated, but coal at \$3.00 a long ton seems to be about fair. The calorific value of the coal will be assumed about 14,000 B. T. U.; that of the crude oil about 19,000 B. T. U. Coal would cost 13.4 cents a hundredweight, and oil at the same cost per B. T. U. would cost 13.4 cents for 73 pounds. On this basis steam power would cost the same, as far as the fuel was concerned, regardless of whether coal or oil was used. Oil at 13.4 cents for 73 pounds is about equivalent to 1.41 cents per gallon.

The *Mariposa* is 314 feet long, 41 feet beam, and 22 feet mean draft. The vessel was, at the time of being remodeled, fitted with tanks to carry 905.43 long tons of oil, sufficient to last the round trip from San Francisco to Tahiti and return, a distance of 7,098 nautical miles. The I. H. P. of the vessel is 2,500, and therefore the B. H. P. must be given about 2,100. The power of the auxiliaries was not given. The second trip of the *Mariposa* was more economical than the first, owing to the experience gain-

ed on the first trip, and perhaps, also, on account of the fact that it was made at a slightly slower speed. On this second trip 734.14 tons of oil were consumed. On a basis equal to \$3.00 per ton for coal, this oil would be worth \$4.09 per ton, or the total fuel consumed on the trip would be worth about \$3,000. The average efficiency on the trip may be assumed to have been about 9 per cent, based upon the B. H. P. of the main engines. As the power of the auxiliaries is not known, it will be necessary to credit the main engines with the assumed power consumed by them; 995 tons of coal, at the above mentioned calorific value, would have been required to get the same results as were obtained with the 734 tons of oil. Using a gas producer and gas engine for the power we shall have to reduce the efficiency of 25 per cent to 20 per cent to allow for the extra power in the auxiliaries. The producer would use 448 tons of coal at \$3.00 a ton, or a total of \$1,344 for fuel for the producer-gas plant. Using oil engines for power, the efficiency of 30 per cent would have to be reduced to 24 per cent to allow for the auxiliaries. The equivalent of 2,500 steam I. H. P. would require 267 tons of oil at a value of \$4.09 a ton, or a total value, for the oil engine plant on the trip, of \$1,093.

In Table I. the weights are obtained for total machinery, by assuming that for both steam plants 300 pounds per I. H. P. for the producer-gas plant 280 pounds, and for the oil engine 205 pounds.

Supposing that the *Mariposa* be equipped with any one of the four different types of power mentioned before, with fuel to make the trip to Tahiti and back, the different weights will be as per Table I.

In any engine plant the wages are always an appreciable part of the expense of operation of the plant. Table II. is the actual engine-room force of the *Mariposa* when coal was burned, and also when oil was the fuel; also an estimate of the crew necessary for using a producer-gas plant

and an oil-engine plant, with what seems a fair schedule of wages under the four conditions:

It happens in this case that the wages per month go directly with the cost of fuel per trip since the *Mariposa* makes one trip per month. As stated before, no data was available upon the subject of salaries, but figures given out are no doubt near enough to actual wages, including cost of feeding the men.

It is probable that the first cost of the oil engine plant will ultimately be considerably less than the cost for the same power steam plant. The oil-engine plant will weigh less than the steam plant, and there is no reason to expect that the cost per ton of machinery will be greater than for the steam engine.

The total cost per month for operating the *Mariposa* with the four kinds of power, accounting for the fuel used and the wages paid, may be estimated at \$4,920 for the first case, \$4,035 for the second, \$2,575 for the third and \$1,833 for the oil engine plant. The saving in dead weight over the steam engine using coal is 261 tons for the second case, 568 for the third and 833 for the oil engine plant. This saving in dead load, which could be utilized for carrying more cargo, should be worth about \$3.00 a ton at the very least for the round trip of 7,000 miles. The saving in dead weight, if used up with cargo at this figure, would pay all the expenses of operating the oil engine plant, and leave a surplus of \$656. The cost of operation of the oil engine plant (with all space taken which was available for cargo) would be \$5,576 less than the cost for the steam plant with coal, \$3,908 less than the steam engine using oil, and \$1,530 less than the producer-gas plant.

There is no question but what the writer has taken the figure for the oil too low; but supposing that the price of the oil is doubled, the increase in the price of fuel for the oil engine will not much more than eat up the surplus of 656 left from the extra

cargo carried after taking out the cost of help and fuel. A barrel of oil contains 42 gallons. At twice 1.41 cents a gallon the barrel of oil will be about \$1.20.

To the writer it seems that the stir which is now being made in favor of the turbine of one kind or another will be comparatively short lived. For large powers there are great obstacles to be overcome before the steam turbine will be a success. The large power in a vessel naturally calls for a large propeller with a low number of revolutions. The turbine, on the other hand, to be of its least weight per horse power, must be comparatively small diameter, and have a high number of revolutions. The two conditions may be partially met, but the result will not show either the propeller or the turbine to

its best advantage. There does not seem to be any objection to the design of an engine plant for ocean liners having a power equal to 60,000 I. H. P. and using the crude oil Otto for the power. This could probably be done with twin screws, eight cylinders on a shaft, each cylinder generating about 4,000 H. P. This power could be put into a liner about 600 feet long and better time made than is possible with any practical sized steam vessel. Knowing what is being done in the line of developing the crude oil Otto, and what the promise is for the future, it seems very evident to the writer that any future important stride in marine engineering must be made not with the producer-gas plant or the turbine, but with the crude oil engine.—*Marine Engineering.*

TABLE I.

	Machinery.	Fuel.	Total.	Fuel.	Saving.
Coal burning steam.....	335 tons	995 tons	1330 tons	\$3,000
Oil burning steam.....	335 tons	734 tons	1069 tons	3,000
Producer-gas (coal).....	313 tons	448 tons	761 tons	1,344	\$1,656
Oil engine plant.....	229 tons	267 tons	496 tons	1,093	1,907

TABLE II.

	Coal Steam.	Oil Steam.	Producer-gas.	Oil Engine.
Chief engineer.....	1 @ \$150—\$150	1 @ \$150—\$150	1 @ \$150—\$150	1 @ \$150—\$150
Assistant engineer....	3 @ 100—300	3 @ 100—300	3 @ 100—300	3 @ 100—300
Oilers.....	3 @ 60—180	3 @ 60—180	3 @ 60—180	3 @ 70—210
Firemen.....	12 @ 45—540	3 @ 45—135	6 @ 45—270
Coal passers.....	12 @ 40—480	6 @ 40—240
Water tenders.....	3 @ 60—180	3 @ 60—180
Messenger.....	1 @ 30—30	1 @ 30—30	1 @ 30—30	1 @ 30—30
Storekeeper.....	1 @ 60—60	1 @ 60—60	1 @ 60—60	1 @ 60—60
Totals.....	36 1,920	15 \$1,035	21 \$1,230	9 \$750

WOOD GAS FOR GAS ENGINES.

Wood gas is used in the power plant of the Montezuma Copper Company at Nacozari, Mexico, to drive gas engines. There are eight, all told, of the Crossley type, 18.5 inches by 24 inches, in cylinder sizes, each belted to a 65 kw. direct current 250 volt generator. The gas is manufactured in Loomis-Pettibone producers, and to secure an adequate firing zone in the producer a bed of coke is employed, as it was feared that apertures might be burned through a

bed of charcoal alone, allowing tar to pass through untransformed into fixed gas. The analysis of the gas, given by Mr. J. Langton in a paper before the American Institute of Mining Engineers, is as follows: Carbon monoxide 14 per cent, hydrogen 20 per cent, marsh gas 2 per cent, carbon dioxide 16 per cent, oxygen 0.1 per cent, nitrogen 47.7 per cent. Calorific value per cubic foot at sea level and 60 degrees Fahr., 132 British thermal units.

A SUCCESSFUL MOTOR CANOE.

By ARCHIBALD W. SMITH.

Great interest has been aroused in the development of small motor craft, and while there are many classes of motor boats, so far as we know the motor canoe described here is the only successful one in operation.

It is an ordinary stock paddling canoe 18 feet long, 35 inches beam, 14 inches deep, and as seen in cut No. 1 there is built on from about the center of the keel to the stern a "skeg," through which the shaft runs to a



Canoe with Skeg, Propeller, Etc.

point sufficiently low to keep the propeller submerged under all conditions, which, as far as I can find out, was the main difficulty experienced by others.

This "skeg" not only answers the purpose mentioned, but also provides a good long bearing for the shaft, and stiffens the canoe considerably. It is fastened through by bolts sufficiently long to be riveted underneath to the one-inch half-oval iron which serves as a protection to the keel, and is carried from the bow to the stern, at which point it projects as a shoe protecting the propeller blades from injury either while running or landing. The rudder is attached to this shoe, and steering can be controlled from any part of the canoe, as an endless cord runs through screw eyes and pulleys attached to the gunwales.

Motive power is supplied by a two-cycle single cylinder 1 H.P. gasoline engine, set up exactly in the center of the canoe. It is fastened to a bed made from two 4-foot

pieces of ash, laid longitudinally, with two cross pieces formed to fit the shape of the bottom of the canoe. These pieces also act as braces, and are fastened from the outside by brass screws.

The propeller shaft from the engine to the skeg is encased in brass tubing, and is supported by two bearings about two feet apart. This stationary casing also acts as a bearing where it enters the skeg, and the shaft can always be kept lubricated, and, notwithstanding the 9-foot length of the shaft, there has been no side play.

The gasoline tank (capacity three gallons) is in the bow under the decking, and a lead pipe conveys the gasoline to the carbureter. This worked all right in smooth water, but where rough water is the rule I advise cylindrical tanks placed amidships. Battery box, spark coil and switch, together with the connecting wires are water proof, and are within easy reach of the party running the engine. The discharge pipe from the water jacket is run through the muffler. A tool box is used as a seat by the party running the engine, and while one person can easily operate the canoe, I found that with carrying two or three people better speed could be obtained. Four adults can sit comfortably in the canoe, and an average speed of a little



Canoe Landing.

over ten miles per hour during the past season was obtained with the equipment described.

The cost of the canoe equipped is about \$180, and when fully loaded the draught is less than 12 inches.

It is impossible in a short description like this to give details, but I am confident that this type is not only the ideal one for pleasure seekers, but that it will also appeal to prospectors, explorers and surveyors, who

need something portable, safe, speedy and strong enough to stand hard usage. As an illustration, I might state that in August, with fairly choppy weather, on Lake Ontario, we carried in the canoe four adults and two children and towed for several hours an 18-foot rowboat containing as many more people.

I found the canoe very steady in the roughest weather, easily steered and quite dry.

THE EFFICIENCY OF THE GAS TURBINE.

With the rapid and successful development of the steam turbine it has occurred to a number of engineers that a similar successor to the gas engine in the form of a gas turbine might readily be made. Some experimental work has been done, both in the United States and in Europe, but very little information has been made public, this indicating that the practical results have not been attended with that degree of success which would warrant any commercial undertakings. It now appears that Messrs. Armengaud and Lemale have been running an experimental turbine, driven by the direct products of the combustion of petroleum at constant pressure, and that this machine has been in operation for more than a year in the works of the *Societe des Turbomoteurs* at Saint Denis, near Paris.

In a recent issue of the *Schweizerische Bauzeitung* this machine is described in a contribution by M. Alfred Barbezat, who proceeds to develop a theory of its action by means of which the efficiency for any given temperature range may be computed. The mathematical nature of the article is such that it can not be reviewed at length, but must be studied in the original, although the results are expressed in graphical diagrams which are useful as means of applying the results. A section of the generator

and machine is also given, showing the extreme simplicity of the apparatus, and its applicability as a motor.

It is not maintained that the gas turbine will give a higher thermal efficiency than the reciprocating gas engine, but it is believed that to all the great advantages of the gas engine will be added those of the steam turbine, including simplicity, continuity of action, lightness in proportion to the power developed, economy of space, together with freedom from the incumbrance of boiler and furnace. An important advantage especially is seen in the substitution for the intermittent action of the Beau de Rochas cycle, of a continuous tangential impulse upon the rim of the wheel, the gain in this respect being greater for the gas turbine over the gas engine than in the case of the steam turbine over the reciprocating steam engine.

In the Armengaud and Lemale apparatus the combustion takes place in a pear-shaped vessel, the air and petroleum being delivered under pressure at the large end, through a special form of burner.

The burner is of annular form, the liquid fuel being delivered in the middle and the air around it, while the gases and products of combustion are discharged from the other end, through a suitable diverging

nozzle, directly against the double buckets of the wheel, this latter being similar in construction to a Pelton water wheel.

The combustion chamber is protected against overheating by a water jacket arranged in the form of a spiral passage formed in the thickness of its walls, the water thus becoming continually hotter and hotter as it proceeds, until it is finally discharged in the form of vapor into the interior of the chamber through a series of small holes arranged around the entrance of the discharging nozzle. The intense heat at this point adds to the expansive force of this vapor of water, and thus all the heat which has been absorbed by the water jacket is delivered with the hot gases against the turbine wheel as energy. The air, liquid fuel, and circulating water are delivered by suitable pumps deriving their power from the turbine itself, so that the available power is the difference between that generated by the turbine and that absorbed by these pumps. In the Armengaud and Lemale generator a temperature of 1,800 deg., C., is maintained in the combustion chamber, the constant expansion of the gases and vapor of water causing a stream of high velocity to be discharged through the nozzle upon the buckets of the turbine wheel.

M. Barbezat takes the data derived from these experiments, and discusses them in accordance with the thermodynamic theory

of gases, drawing curves corresponding to the energy evolved as well as that consumed by the air compressor, from which it appears that with a temperature of combustion of about 1,800 deg., C., and a temperature of discharge of 920 deg., C., in the gases delivered against the wheel, the efficiency of the apparatus will be about 18 per cent.

In this case the initial pressure is about 15 kilogrammes per square centimetre, or about 212 pounds per square inch, and this performance is not better than is already obtained with the reciprocating gas engine, and is decidedly lower than is given by the best petroleum motors, such as the Diesel. At the same time, the advantages of the continuous rotary motion, together with the simplicity of the machine, renders it important that thermal efficiency alone should not be made the criterion by which the machine is judged. It is also possible that higher pressures may be used to advantage, and that the temperature range can be increased, so that still better results may be attained. The fact that a practical gas turbine has been made and operated continuously is in itself a matter of technical interest worthy of note, and if the machine receives but a portion of the attention which has been given to the steam turbine or the reciprocating gas engine, it is probable that further improvements will be made.—*The Engineering Magazine*.

A ST. LOUIS EXHIBIT SOLD.

The complete World's Fair exhibit of the Weber Gas and Gasoline Engine Co., of Kansas City, Mo., which was in service in the Steam, Gas and Fuels Building during the Exposition period, has been sold to the Christopher E. Hertlein Company, one of the largest and oldest manufacturers of dress and cloak trimmings in New York. The plant consists of 150 H.P. Weber engine and 150 H.P. Weber suction gas pro-

ducer, direct connected to a 75 K.W. Western electric generator. The plant will be located in the heart of New York City,

This is said to be the first producer gas power plant to be located in New York City. The engine and producer secured the highest award for the Weber people at the St. Louis Exposition, and that it should be located in New York is owing to the fact that it is being supplied to the manufacturers.

**INTERNAL COMBUSTION ENGINES AT
KEY WEST.**

One of the first of our southern enterprises to take advantage of the cheap oil of Texas, was the Key West (Fla.) Electric Company, a company that owns the electric light and railway franchises for the city and island of Key West. Over a year ago this corporation, foreseeing the evident economy of oil burning engines over steam engines, made their first installation of internal combustion engines. After a year's trial on both railway and lighting service, they are making a complete substitution of the new power. The scarcity of fresh water on the island, the only source of which is rain, makes the internal combustion engine particularly serviceable for this locality. The internal combustion engines do away with all the difficulty of securing water for steam plants, and at the same time reduce a fuel bill of something over \$24,000 per annum to less

than \$6,000. Such economy in a small plant is easily understood only when it is remembered that coal costs \$5 a ton in Key West.

It is said that the Key West company was the first corporation to make use of gas engines in operating a trolley line. There will soon be a 600 H.P. of these engines in full operation in their power house, and then the steam plant will be entirely shut down.

In addition to the above advantages, the use of gas engines reduces to a minimum accident fire insurance, and the other very serious question in hot climates, that of furnishing firemen and engineers in the steam plant, is entirely removed. In some cases in the south three shifts of men have been necessary during the heated season, because of the additional heat of the steam boiler and engine. With the internal combustion engine no skilled attendance is necessary.

ALTERNATING CURRENT ELECTRIC TRACTION.

The Warren & Jamestown Street Railway Company, Warren, Pa., is installing an alternating current, single-phase, electric railway system, to operate between Warren, Pa., and Jamestown, N. Y.

The power station will be located at Stoneham, Pa., two miles from Warren. The initial equipment will consist of two Westinghouse gas engines, each of 500 B. H. P. They will be of the horizontal single-crank double-acting type, direct connected to two 260 kw. Westinghouse generators furnishing current at voltage sufficient for direct use upon the high tension transmission line. The power equipment also comprises a 55 H. P. Westinghouse gas engine for operating air compressor and exciter unit.

An interesting feature of the system is the arrangement for operating the alternating current motors upon the direct current trolley lines within the city limits of the termini.

The Warren & Jamestown Street Railway is not a newly organized system, as it has operated part of the present lines for a period of eleven years. Three years ago the company began experimenting with the use of gas power, with sufficient success to influence them in the now exclusive adoption of gas engines for their entire power generation. The operation of the new system will be watched with much interest by the engineering public, and its success will mark an important advancement in modern electric railroading.



An English firm proposes to use a solid fuel for internal combustion engines. A naphthalene ball is the fuel. Exhaust heat reduces the solid to the consistency of treacle. The engine is started on gasoline, then runs on heavy petroleum and finally naphthalene. An injector forces the fuel into the engine.

Speaking of two French manufacturers deciding to bring out six-cylinder cars, a Frenchman recently said: "If we compare motors of the same horsepower, but different as to the number of cylinders," he said, "and if these motors are driven at the same speed, we will find that, by taking for a base the weight of the flywheel of the one-cylinder motor at 100, the weights of flywheels of the other motors will be as follows: For two-cylinders at 180 degrees, 0.63; for two cylinders at 240 degrees, 0.20; for four cylinders at 180 degrees, 0.07; for six cylinders at 120 degrees, 0.01."

Reliability covers very completely the essential features of any class of machinery. No matter whether its price is relatively high or low, no matter whether it is in common use or not, it must be reliable to be a commercial success. Tests for reliability are, therefore, always in order. In the main, the test of reliability must be conducted by the public, for it does not matter if the manufacturer finds the machine reliable; his customers must find it reliable. The general reliability, as determined by the users of a machine under the conditions of service, will

in time become known more or less generally. But, for the advantage of those who have not had opportunity to learn of the reliability as determined by every day use, the manufacturers frequently endeavor to show, by reliability tests of their own, the durability and general satisfactory characteristics of their machines.

The trouble with such reliability trials is that they either do not represent the actual conditions of use to which the machines will be put, or else they are conducted in the hands of expert operators who know, if any one can know, what to do in any emergency, as well as in ordinary useage.

The Automobile Club of Great Britain and Ireland has adopted new rules covering the long-distance reliability trials held by it. First, a "day" is to consist of thirteen hours, eleven of which may be spent in operating the contesting car. A day's run must not exceed 200 miles, while the whole trial will cover a distance of not less than 500 miles. During the morning half an hour may be spent adjusting the car, and later in the day one and a half hour may be spent in washing, adjusting, etc. Observers will have control throughout the trial. A speed of not exceeding 19½ miles per hour may be attained for the average run. Voluntary stops may be made for reasons made necessary by other traffic, etc. Involuntary stops mean the stops caused by failure of any part of the car, or for adjustments or repair, which, if not made, would result in such failure. Fuel, water and lubricating oil consumptions during the trial are to be noted.

A BRITISH AGRICULTURAL MOTOR.

An English contemporary gives the following information relative to an agricultural tractor in use there, employing a gasoline motor for power:

Motor car owners who are also landowners, farmers and agriculturists generally, will doubtless be greatly interested in one of the latest developments of the gasoline motor and its successful application to a major portion of agricultural and farm work. The agricultural motor is now an accomplished fact, and has fully proved that it can do almost any kind of farm labor and much useful work besides.

A high-speed gasoline engine, it is almost needless to state, can be geared down to perform any kind of work requiring slow movement combined with maximum power, thus rendering it capable of being turned to account to perform any kind of traction work that can be done by horses, while at the same time, by means of an auxiliary belt pulley, it can be used as a stationary engine to drive all kinds of machinery used in dealing with agricultural produce.

The latest form of agricultural motor is somewhat like a small motor car for one rider, but has only three wheels. The engine is about 18 B. H. P., of the horizontal type, with two opposed cylinders, and runs at from 650 to 800 r. p. m. The transmission is by chains or gearing, and one motor has two clutches—one for forward motion and one for reverse. The two rear wheels are about nine inches wide, and usually have transverse grips fitted on the treads similar to traction engine wheels. The front wheel is usually the same width, but has also fitted on the center of the tread a solid rubber tire, the advantage of this being that the machine can be turned in a very small space, the solid rubber ridge on that wheel gripping the ground well.

The broad wheels enable the machine to

travel over any kind of rough or soft surface, without sinking into the ground. Its total weight is only a little over a ton, and the weight is evenly distributed over the three wheels. The machine performs quickly any kind of farm work, and at a much cheaper cost than would be possible with horse traction. It also has the advantage that it can be applied to all existing agricultural implements and machinery now in use, and that no special implements are necessary.

The machine has a wide range of usefulness, for it will haul plows (for one, two, or three furrows), reaping and binding machines, mowing machines, sowing machines, cultivators, scuffles, and all implements requiring tractive power. It will also drive threshing machines, chaff cutters with any number of knives, winnowing machines, and can also be used for pulping roots, grinding corn, pumping, milling, and, in short, any other farm work which has hitherto required the use of horses or a stationary engine of any kind. It can also be used for cart or haulage. For stationary engine work it has an outside pulley wheel connected with the engine. The machine when used to haul carts can thus take produce to market, so that it is equally useful on the road, the field, or in the farmyard.

The price of the machine is about \$1,500, with all necessary fittings, and will quickly save its cost even on a comparatively small farm. With ordinary care it requires little attention, and when not in use, costs nothing for upkeep. Any person of average intelligence can learn to manipulate it in a short time. It is always ready to perform any work required, and is economical in use.

There are various forms of agricultural motors, but the one principally referred to is the invention of Mr. Dan Albone, of Biggleswade, Bedfordshire, England, a great

A NEW COIL COMPANY.

The Kokomo Electric Company has been incorporated at Kokomo, Ind., for the purpose of manufacturing a full line of high-grade electric ignition apparatus for gas engines, including spark coils, both jump and primary, storage batteries, dynamos and magnetos, spark plugs, commutators and timing devices, switches, wire terminals, etc. This company has purchased the factory and plant of the E. S. Huff Company, of Detroit, Mich., moved it to Kokomo, and added a large amount of new machinery, making it one of the best equipped factories of its kind in the country. A large amount of the stock

of the Kokomo Electric Company is held by members of the firm of Byrne, Kingston & Co., who will handle the entire output of the new plant. Mr. George Kingston, general manager of Byrne, Kingston & Co., will also manage the Kokomo Electric Company, with Mr. E. S. Huff as electrical engineer. The output of this factory, which is already in operation, added to the list of carbureters, mufflers, circulating pumps, oiling devices, steering wheels, etc., of their own manufacture will give Byrne, Kingston & Co. one of the most complete lines of accessories manufactured by any one firm in the country

THE COMMERCIAL MOTOR CAR PROBLEM.

It will be readily appreciated that if the manufacturers of typewriters had offered these machines to business men, without at the same time providing competent operators for them, and making adequate arrangements for supplies, repairing, etc., the typewriter would never have come into universal use as it is today. The introduction of the commercial motor car presents a similar problem to that which confronted typewriter manufacturers. The economy of the typewriter was difficult to demonstrate, because it represented an additional outlay and the employment of an operator, an added expense, while the saving in the time of the important men of a concern could not be demonstrated without considerable actual use, furthermore many business men accustomed to writing letters were loathe to attempt dictation, to which they were unaccustomed.

These were very serious obstacles, and yet they have been so completely overcome that there is not an intelligent man who today combats the economy and utility of the typewriter in business.

The obstacles to the introduction of commercial motor cars are very similar. Their first cost is greater than the horse-drawn vehicle, they require special operators, as the driver of a horse can not operate a motor car without first having been taught how to do, so, and provision must be made for supplies and repairs that will keep the vehicle in good running order. Further, the saving secured by the use of motor cars can not be demonstrated except by a somewhat extended practical use and busy business men do not wish to have the additional bother of looking after this new method of making deliveries, but would rather stick to the horse conveyances to which they and their employees are accustomed.

It will, therefore, be seen that the commercial motor car makers' problem is almost exactly the same as was the typewriter makers', and therefore the commercial motor car maker and the dealer who handles them should study carefully the methods which so successfully introduced the typewriter.

The typewriter manufacturer did not try to sell his product until he was prepared to

AN ENGLISH VIEW OF AIR-COOLING FOR MOTOR CAR ENGINES.
--

Air-cooling is at the present time of very little importance in motor car constructional practice—or, at least, in British motor car practice. The average motorist, when air-cooling as a possible development of the motor car is mentioned, gives a most contemptuous sniff and smiles. He agrees that it has been used—and used very successfully indeed—for motor cycle work, but he points out at the same time that on the heavier forms of motor cycle air-cooling is rapidly becoming obsolete, and that water-cooling is taking its place. However, because this attitude is taken here, and although British motorists are almost completely ignorant of air-cooling in practice, our fellow-workers in the States are taking up the question very thoroughly—so thoroughly that many automobile manufacturing firms there are producing cars the engines of which are air-cooled. Moreover, since these cars are made and the firms do business and prosper, it is very evident that air-cooling under the conditions which American automobiles have to compete with when in the land of their production is both possible and satisfactory. Let us come nearer home, and consider for a moment the well-known Lanchester car, which so many wise motorists deride continually because it is air-cooled. There are few cars more reliable, and there are few which will run as far without attention. A Lanchester engine will run, day in, day out, without stopping and without giving trouble from its cooling system; but it is air-cooled. True that this system is a specialized one, and that the propulsion of the cooling apparatus (fans) absorbs a good deal of power; but the fact still remains that the system is practical, has stood the test of use, and the cars so arranged bear favorable comparison with the water-cooled machines of equal power.

Air-cooling is, perhaps, the oldest form of cooling for internal combustion engine cylinders, since in the early days of gas-engine development—long before the autocar engine was put into practical shape—the original gas engine, embodying the inventions of Lenoir and others were, we believe, without cooling jackets, the heat simply being dissipated from the outer surface of the cylinder. Coming into the range of automobile practice, we have many examples of more or less successful air-cooled engines, although many of us have a very present recollection of the defects of those engines. For motor cars, air-cooling was dropped very quickly, giving place, of course, to the now universal water-cooling system. Lanchester was the only inventor of note to maintain it, and he employed a specialized system. As regards air-cooling among British manufactured cars, the Lanchester was and is without a rival, either good, bad or indifferent.

On the Continent only two makers, as far as we know, continued to manufacture air-cooled engines of high power, and even these gradually died out, until at the present time there is not a single high-powered motor car engine made with air-cooling on the Continent, to the best of our belief. In America, however, the case has been different; air-cooling has there been regarded as a desideratum, and, consequently, much ingenuity has been brought to bear upon the solution of the problem, with the result that there are, in all probability, a score of makers throughout the States, each of more or less note, who pin their faith securely to air-cooling as applied to the engines they manufacture. A glance through the advertisement pages of practically any American automobile journal will probably reveal several of them, and from a study of the small illustrations generally accompanying the ad-

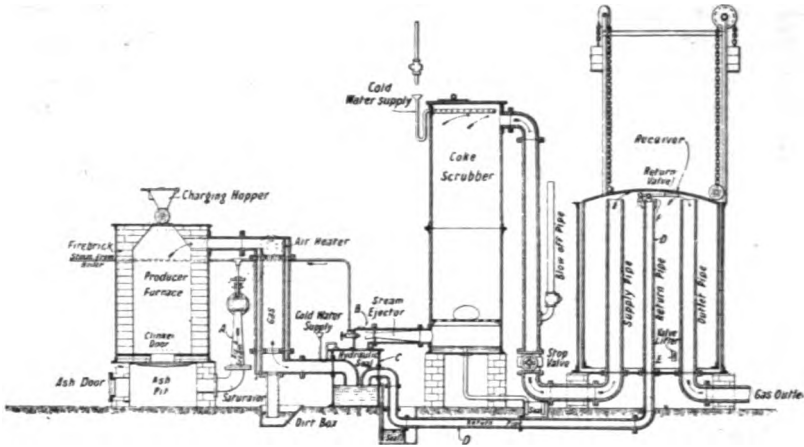

sucking gas from the producer, sucks it from the regulating gas receiver through the return pipe to the seal box, whence it is re-circulated.

The gas, circulating in this way, prevents any fresh gas from being withdrawn from the producer until the bell regulating receiver again falls and closes the return valve. Obviously, only air and steam are drawn through the producer when the ejector is sucking upon it, and in amount required to make the quantity of gas to keep the receiver full. As a result there is secured a uniform quality of gas.

These producers have an open ashpit, so the fire can be cleaned without interfering with the gas making. Anthracite coal, coke, or charcoal is recommended for these producers in small plants. Bituminous coal may be used in large ones, but bituminous producers require more attention than those using other fuel.

While the automatic producers may be used for supplying gas for power and fuel, the suction type is used where power alone is required, and where space is limited and

the coal is fairly uniform. They occupy less space than the automatic type, but more costly and special fuel and do not have the regulation for uniform quality of fuel. From 5 to 15 per cent of their engine power, depending upon the size plant, is required to produce a draught, and for a successful installation gas engines should be installed of ample capacity to do this and make up for non-uniform quality of gas. Anthracite coal, charcoal or coke may be used for fuel.

The third type of Wile producer, the "water bottom producer," furnishes large quantities of hot gas for fuel to take the place of coke or coal fires. Gas may be furnished at a total cost of 18 cents per 1,000 cubic feet. This type derives its name from the water bottom trough with which it is provided.

The automatic and suction types of producers are built in units from 500 H. P. down to very small sizes. The Wile Company gives the following annual fuel cost for a brake horse-power, for 300 days, 10 hours a day, for different kinds of fuel:

	Per B. H. P.	
Producer gas, coal, \$3 to \$5 per ton.....	\$4 50	to \$7 50
Producer gas, coke, \$3 to \$5 per ton.....	\$6 75	" \$6 50
Natural gas 25c to 30c per 1000 cubic feet.....	\$9 75	" \$11 75
Coal gas, 75c to \$1. per 1000 cubic feet.....	\$40 50	" \$45 00
Gasoline, 12c to 16c per gallon.....	\$45 00	" \$60 00
Electric current 3c to 6c per unit.....	\$60 00	" \$100 00
Steam, coal \$3 per ton.....	\$9 00	" \$36 00

GASOLINE ENGINES IN NEW ORLEANS.

A recent fire in New Orleans has caused an unwarranted attack on gasoline engines there. The fire referred to was in another industry and was occasioned by carelessness in the use of gasoline. At once the authorities have rushed to the conclusion that a gasoline engine is dangerous. In one case the Chief Engineer of the Fire Department is reported as having said that "the room in which the engine is located is 16 by 8 feet, with the gasoline tank in the ground twelve feet distant." If the tank is situated twelve feet distant from any building, and if the gasoline is taken to the engine by a small pump and there is the usual provision for overflow back to the tank, there can be no possibility of a fire from the engine if the supply and

overflow pipes are properly connected up. The only possible chance for a fire would be when filling the tank, and as the insurance companies usually require this to be done in day light, there is very, very little chance of a fire. In fact, the danger from fire in such case is less than the danger in having a tank wagon in the streets. Certainly the danger is much less than the possibility of a boiler explosion from the many poorly built, ill-cared for plants in use in many cities.

It is to be sincerely hoped that the authorities of New Orleans will not handicap the use of so admirable and safe a power, merely because some one in the city has been careless in the use of gasoline for cleaning garments.

CASTING ALUMINUM.

The matter of casting aluminum is assuming such prominence, that a little general information on this subject will not come amiss. It is important to make the mold suited to the casting. For instance, a plain bar can be molded up as hard as may be, and if well vented, will come out perfect. On the other hand, a thin ring, unless molded up soft enough to allow the metal to compress it, will be sure to tear apart. Hence, wherever the metal is to enclose the sand, this must be left as soft as possible, to allow for compression during the cooling of the casting.

Ram the sand as little as possible, use as dry as possible, vent freely, and you are pretty safe. Aluminum is quite brittle at the critical temperature, hence the least strain at that time injures it. Cores should be soft, and coated with graphite. The sand should be new, and while no facing is necessary, a

good dusting with soapstone can be recommended. The slicking tool should never be used on a mold.

Melt the aluminum in a plumbago crucible, previously rubbed up with graphite. When the metal is melted, it should be poured at once. Gates should be wide, and of a generous area. Big feeder heads are not advisable, as they do not feed, but rather draw away the metal from the casting. The metal should not be too hot, a good claret color is sufficient, when observed by putting aside the skin with a stick. Fluxes are unnecessary; occasionally, however, cryolite may be used to advantage. All sodium salts should be kept away. Zinc can be added, though the metal should not then be sold as an aluminum casting. Up to 15 per cent can be used safely. Tin should also not be added to the aluminum.—*The Mechanical World.*

THE "B. AND C." FRICTION CLUTCH PULLEY

There are special points connected with the attaching of a friction clutch pulley to gas engines which make it advisable to use a clutch specially constructed for the service. The "B. & C." clutch bolts directly on the flywheel of the engine and takes the place of the regular driving pulley. Where engines are used in shops, driving a line of shafting, it is particularly advantageous to have the clutch pulley on the engine where it can be easily adjusted and oiled.



"B. & C." Friction Clutch Pulley, Front View.

Figure 1 shows the front view of the "B. & C." clutch, while the application of the clutch is shown in Figure 2. This view also gives a good idea of the construction of the clutch, which consists of three main parts: the pulley, the carrier, which is bolted to the arms of the engine flywheel and acts as a journal for the pulley, and the gripping mechanism, which consists of a gripping plate, spindle and cam levers. The clutch has a side grip, which eliminates the effect of centrifugal force and insures a positive release.

Two rollers are mounted on the end of the spindle, which works in and out through a hole in the gripping plate, and journaled on

the end is the operating hand wheel, which can be held in the hand regardless of the speed of the engine. Bearing on the rollers are cam levers, which in turn are pivoted on the gripping plate, and lugs on the levers abut against the adjusting screws. These adjusting screws go through a flange on the carrier, and are locked in place by the lock nuts, which also hold the gripping plate in position.

In the operation of the clutch, when the spindle is pulled out against the stop, the pulley is free to turn on the carrier journal and when pushed in is gripped in a circular vise and turns with the engine flywheel. The load can be taken up as gradually as desired by pushing in the handwheel slowly, and released at will by pulling it out.

Messrs. Patterson, Gottfried & Hunter, Ltd., 150 Center street, New York City, are the distributors of the "B. & C." clutch, and will be pleased to send prices with full particulars and a copy of their latest illustrated catalogue on application.

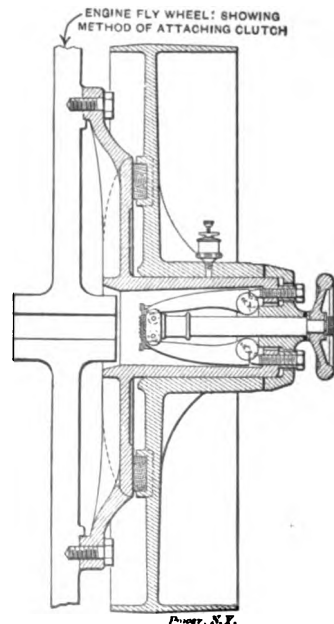

"B. & C." Friction Clutch Pulley, Sectional View.

TRADE PUBLICATIONS.

"The Rambler Magazine" is the title of a new monthly to be issued by Thos. B. Jeffery & Co., Kenosha, Wis.

The Winton Motor Carriage Co., Cleveland, O., have issued a very fine catalogue showing their 1905 four-cylinder vertical cars.

Pumping Machinery is the title of a 132-page catalogue just issued by Henry R. Worthing, of 114 Liberty street, New York City.

The Hill Tool Company's "Facts About Tool Holders" is a small catalogue from the Hill Tool Company, Anderson, Ind. It lists tools for facing, boring, turning, etc.

For several years we have been using one of the American Steel and Wire Co.'s desk calendars, and have just received the 1905 pad. It is supplied with a suitable wire and iron frame.

The Wm. Powell Co., Cincinnati, O., have just issued a very attractive souvenir of their "White Star" values, in the shape of a watch charm. It will be sent free to engineers on application.

The "Reliable" engines, 1½ H. P. and up are built by the Reliable Machine Company, Anderson, Ind., which company has recently purchased ground and will erect a building especially for their own use.

The Marion Motor Car Co., Indianapolis, Ind., employ an air cooled four-cylinder motor in their cars, and a catalogue received from them devotes considerable space to explaining the features of their motor.

A very complete and excellent line of automobile parts is shown in the 1905 catalogue just received from the J. H. Neustadt Co., St. Louis, Mo. Everything necessary for complete cars, and several styles of many parts, are listed.

A recent automobile advertisement states that a horsepower is the power required to "lift 33,000 pounds one foot per hour." *Printer's Ink* remarks that perhaps that is the horsepower of the car in question.

The Lambert Gas and Gasoline Engine Company, Anderson, Ind., have a well-printed catalogue in two colors, showing the "Lambert" engines. This company recently moved into a new concrete factory built for their special use.

The Perfection Magneto Company, Anderson, Ind., send us a small folder describing the merits of their "Perfection" magneto for ignition use. Among other specially attractive features they mention interchangeability of parts, and the fact that they make but one style of machine, claiming that this one will do the work, and therefore several types are unnecessary.

From the Stearns Gas Engine Works, Los Angeles, Cal., we have received a catalogue of Stearns engines. An illustration of the engine in four colors occupies a prominent position. The engines are of the hit and miss type and are built in units from 2 to 20 H.P. Mr. Stearns has recently returned to Los Angeles after an extended trip through the East, purchasing new machine tools, etc.

The Bessemer Gas Engine Company, Grove City, Pa., is one of the few companies making a business of converting steam into gas engines. The gas engine cylinders and parts may be attached to any steam engine having an overhanging cylinder. A new catalogue from this company gives complete information relative to these outfits, as well as the Bessemer gas engine, which is built in units from 5 H. P. up. Engines are built for electric light, ordinary commercial and oil field service.

INDUSTRIAL ITEMS.

A large gas engine is being installed at the Upper Sandusky (O.) water works.

The Simpson Heater Co., Newark, O., will buy a 50 H.P. engine March 1st.

It is reported that Fairbanks, Morse & Co. are bringing out suction gas producers.

F. L. Bane, Brecon, O., contemplates buying a 2 H.P. gasoline engine for sawing wood.

The Globe Iron Works Co. recently removed from Minneapolis to Menomonie, Wisconsin.

A Columbus gasoline engine was recently installed at the Russell & Baer coal mine, Pomeroy, O.

The Lawrenceburg (Ind.) Granite & Marble Works have installed a pneumatic plant for cutting tombstones. A gas engine furnishes the power.

W. S. Sheppard, consulting expert on power, has removed from 34 Ward street to 21 Lawrence street, Newark, N. J. Mr. Sheppard is making special grades of oils for gas engine and automobile uses.

Springfield Gas Co., Lancaster, O., has recently installed an engine of 1,000 H.P. at their pumping station near the mouth of Clear Creek. A steam plant was the former method of operation.

"Captain Tolman says he will be on hand next spring with a new 16 H.P. gasoline engine in his boat, and thinks he can make more money than a big steamer can on the Omro-Berlin route."—Berlin (Wis.) *Journal*.

We have an inquiry from a gas engine salesman who desires to hear from manufacturers of trucks on which to place gasoline engines for traction rigs. We shall be pleased to hear from interested manufacturers.

The S. Obermayer Company, Cincinnati, O., manufacturer foundry supplies and gasoline lubricants for gas engine cylinders, has been awarded the highest award and gold medal at the St. Louis Exposition, on plumbago, foundry facings and foundry supplies of all kinds.

In a bunch of press clippings we recently noticed mention of sales of gas or gasoline engines for the following classes of services: Printing press, circular saw, meat market, ditching machine, pumping water, sausage grinder, machine shop, hook and eye factory, repair shop, grain elevator, electric generator, portable sawing outfit and boats.

The plant of the Jackson (Mich.) Engine and Motor Co. is operated by a 15 H.P. gas engine. It operates the entire plant, consisting of seven lathes, five emery wheels, two planers, a shaper, saw and wood lathe, and also furnishes power for a 125-light generator. The total cost for operation is 95 cents a day.

"No competition under the sun." This is the claim put forth in a circular received from the Wooley Foundry and Machine Works, Anderson, Ind., who state that they are the only manufacturers of gas engines who have adopted the automatic system of governing. This company is also prepared to furnish suction gas producers.

The Automatic Machine Co., of Bridgeport, Conn., have recently installed one of their 60 H.P. four-cycle three-cylinder engines for Ockers & Co., of New Haven, Conn. This is said to be one of the largest and most complete outfits in the business. The boat is 72 feet over all, 20 feet beam, 5 feet draught, 35 net tons, 40 gross tons and has a capacity of 2,500 bushels of oysters, and recently caught 1,000 bushels in two and one-half hours. It has an average speed of ten miles per hour.

THE GAS ENGINE.

STATIONARY—AUTOMOBILE—MARINE.

PUBLISHED MONTHLY BY

The Gas Engine Publishing Co.

Blymyer Building, Cincinnati, Ohio.

ADVERTISING RATES ON APPLICATION. Address All Communications to the Company.

Entered at the Postoffice at Cincinnati, Ohio, as Second Class Matter Feb. 20, 1899.

VOL. VII.

FEBRUARY, 1905.

No. 2.

Domestic Subscriptions, \$1.00 per Annum.

Single Copies, 10 cents.

Foreign, \$1.50 per Annum.

Bound volumes may now be secured for the year 1904. The price of these is \$2.00 each.

We were somewhat delayed in getting out the book, "Suction Gas," by Mr. Haenssger, but we now have a stock of them on hand, and orders can be filled on receipt.

We have also exhausted the fourth edition (sixth thousand) of Mr. Roberts' "Gas Engine Handbook," and have issued the fifth edition, making the eighth thousand. No changes have been found necessary since the last edition, and the present edition is identical with the last one.

The practice of indicating gas engines is by no means as common as it should be among engine users. The article in another column on gas engine troubles gives an instance of how trouble may be located, or saved, by an indicator.

A contemporary calls attention to the fact that modern agricultural machinery has made farm work less laborious than in the older days and that today the chores around the farm constitute the drudgery rather than the easier portion of the work. Farmers who have purchased gasoline engines have found that not only was much of the drudgery banished, but the engine made possible conveniences not otherwise obtain-

able except at a much greater expense. The farmer's wife has water in her kitchen, runs her churn with the engine, has firewood sawed by the power of the engine, etc. The farmer's stock has plenty of water in dry as well as wet seasons, and is supplied with ground feed. In fact, the gasoline engine is doing its share to lighten the labors of the farm and add luxuries not heretofore possible.

"The ingenious American who can make the windmill a success for operating other farm machinery, besides pumping, will have secured his fortune," says the United States Consul at Windsor, Nova Scotia. About the nearest that has been attained, it seems to us, is the gasoline engine.

An English patentee claims advantages from the use of a fan-like projection placed on the end of the connecting rod and projecting from the piston pin toward the inner end of the piston. The motion of the fan creates a draft of air in the piston, cooling same.

A correspondent in an English paper, in commenting on the "specifics" recommended for reducing London fogs, says: "The best means of bringing about reduction are, of course, the abolition of the factory chimney by the adoption of motive power supplied by gas," etc. The gas engine is not only economical, reliable and convenient, but also a good smoke preventer.

G A S E N G I N E P U M P I N G P L A N T S

When the earlier makes of gas engines began to reach the state where they could be depended upon with certainty, the first stage of gas engine construction was over with. The engine had then passed from a condition of purely experimental value to a stage of genuine commercial usefulness, for there are few places in which power is used, where it is possible, or at least practicable, to use for power an engine which may stop at any time, or refuse to start when required. To say nothing of the labor lost, the delay in output of a factory means a great loss if the shop is shut down by reason of failure of the engine to run when needed.

But when the engine could be counted on with absolute certainty to start when wanted and to run continuously when started, the usefulness of the gas engine advanced quite materially. This reliability and certainty of meeting any requirements is particularly essential in certain classes of work, as, for instance, in an automobile. In some cases, failure to fulfill these requirements means a terrific loss of property, and possibly of human lives. Such is the case in city pumping plants, particularly when water is required for fire service. Possibly the fact of there being such absolute need of certainty in the operation of the engine has prevented to some extent the adoption of gas engines for municipal water works plants. However, these installations are increasing in number and the satisfactory service of the plants in operation adds materially to the arguments that may be presented in urging their adoption.

Aside from the saving in the cost of fuel in most plants, which apply just the same as in other gas engine installations of any given size, there is a special saving due to the intermittent manner in which

many municipal plants are required to be run. For instance, in a small town in Ohio, where such a plant is now being installed, there is required for ordinary uses but a small size engine. To provide adequate service for fire protection, however, about a 35 or 40 H.P. will be installed, which will give ample capacity in case of fire. This engine, however, in ordinary circumstances, will keep the town supplied with water by running the engine and pump but two days each week. The remainder of the time the engine need not operate, provided it is not required for supplying water for fires. It is quite evident that there will be considerable saving effected by not being obliged to keep the engine under way all the time, this saving accruing from saving in the fuel as well as the time of the engineer, who may possibly be used on other work a portion of the week.

It may be said that a steam plant might be utilized with the same advantages, but this is not the case for the reason that a fire may break out at any time, when the pumping plant would have to be called into service. The gas engine outfit may be started off at once, while a steam plant would not be able to respond promptly unless steam were kept up all of the time.

Of course, there are the other advantages which apply to all gas engine plants, in that there is no hauling of coal or ashes; cost of repairs, etc., should be less; there is no lost fuel in starting up, or in shutting down, etc.

Taking even the larger plants in which gas producers may be used in conjunction with the gas engines, the fact that the manufacturers will guarantee and can produce a horse-power per hour for each pound of coal as against from three to five pounds of coal for even well-equipped

and well-handled steam plants, it is evident that the gas engine pumping station is a very marked improvement

Philadelphia has a special high-pressure gas-driven plant for fire protection, and the reports from its tests have been very flattering. In a large city such a plant

has the advantage (which does not always apply to small towns) of occupying so much less space than would be required for the equivalent steam outfit, that the saving in cost of ground for the gas engine pumping plant is quite a material amount.

S O M E G A S E N G I N E T R O U B L E S

An English correspondent of the *American Machinist* gives some interesting troubles which he has encountered with gas engines. He describes the trouble with a 30-H. P. engine, with water getting into the cylinder, as follows:

"The usual symptoms—refusing to start and bursting tubes—were present. I diagnosed it as a leaky liner joint. The liner was drawn and a new joint carefully made, every precaution being taken. The facing on the end of the liner and its seating in the combustion chamber were scraped, a new asbestos ring was inserted and the liner pulled into place. Imagine my surprise on starting up the engine to find that water was still as much in evidence as ever. The boss of the place (a printing office) was getting sore, and I was wondering already what he would have to say about the bill. There was nothing to do but pull the jacket down again and take out the liner. This time the joint faces were skimmed in the lathe and I felt pretty sure that they would hold this time. After working all night so as to get them started at 8 o'clock next morning, we got the liner back into place and again started up. Alas! the troubles were by no means over, the water whistled down the air valve spindle and out of the lubricator on the top of the cylinder. It could not be the liner, and the exhaust chamber was as dry as a bone. The office had been standing a day and a half and Mr. Printer was naturally getting past holding. We were all pretty well played out, too. The liner was not

cracked, the joints were tight, and yet water in comparatively large quantities was getting in. It looked as tho' we must throw the job up when some trivial circumstance, now forgotten, directed our attention to the air pipe.

"'Get that foot plate up,' the fitter said to one of his mates, indicating the iron plate covering the pit in which the air box stood. 'Now get the top flange off.' The man took the flange off, and to our astonishment discovered that the air box was full of water. The mystery was, of course, solved—the engine had been pumping water on every charging stroke. A leak at some time or gradual condensation had filled the air box, which in this engine was sunk rather low. It all looked so simple, but I have never met with a similar case before nor since. Whenever a man goes from our shop now to see a gas engine with a water trouble the air box isn't overlooked."

"A set of slides off an old slide type engine was sent us one day to be refaced," continues the writer. "The job was done by a skilled hand and returned. Two days after a letter came saying the slides were not properly done and would not hold and that they were being returned to us to be done over again. The letter concluded by saying that of course we would have to bear the expenses incurred by the second refacing. We replied, saying we could not understand why the slides should be wrong, as they had been done in a proper manner and tested on a special test plate before be-

ing sent out. The slides came to hand and were found to be correct. We wrote back, informing our clients of this and asking them to try them again and look in other directions for the trouble. Another letter came, saying the slides were as bad as ever and that we must send down to see to them. We agreed on condition that they should pay the bill if we proved the slides were faced right. On examination our fitter discovered that the lugs on the cylinder end which kept the slide cover in position were bearing against the cover and keeping it away from the slide. This was caused by the thinning of the slide by continual re-facing, and a few rubs with a file put it right."

In another case: "I found the engine stopped with the belt on the tight pulley. After a lot of effort by as many men as we could find room for on the flywheel, we got the belt over on the loose pulley. The engine was got off with a little trouble, but as soon as we attempted to put the load on she started missing fire and in a minute or two stopped. I examined the gas bag, tried the valves up and down, tried the compression, and all appeared right. I was thinking about sending for the indicator when I happened to inquire which wall the exhaust was taken. The attendant said it went a long way to the back of the building and up level with the roof. I inquired if there was a silencer. He said there was a box on the end of the pipe, but he didn't know anything about a silencer. The vagueness of the answer made me suspect that there was a silencer and from his apparent ignorance of it that it had probably not been cleaned since its installation. Up to the roof we went, and sure enough there was a silencer. 'Fetch up a $\frac{3}{4}$ -inch spanner and get that flange off and yell out when you have done it.' Leaving him with these instructions, I went below and waited for him to yell, which he shortly did. As I ex-

pected, the engine rattled off with the load immediately. That silencer gets cleaned out once a year now.

"Go down to Mr. Bootmaker's and look over his gas engine. He says she has sprung a leak.' Jim goes again this time and presently reports that he has drawn the piston and there certainly is a leak, but it doesn't seem to come from either of the joints. As the engine is a small one and the shop quite handy, I tell him to arrange to get the cylinder off and bring it home at shutting-off time tonight. On examination it looked as tho' Jim's version was right. The liner and exhaust joints both appeared tight. Was there a crack? Before taking the liner out we decided to put the force pump on to see if we could detect the spot the water came from. We filled up the jacket, blanked up the bottom water connection and stuck the pump on the top one. A few strokes enlightened us. The water was coming from the indicator hole. We could only conclude that the boss through which the indicator hole traveled from the outer shell of the jacket to the combustion chamber was cracked in the water space. We plugged up the hole on the inside and stopped the leak. If a stranger ever comes to indicate that engine there will be trouble.

"Another hot-bearing difficulty which we traced to an unusual cause was experienced with a large single-cylinder engine giving 120 B.H.P. The engine was some years old when the bearings on the big end of the connecting rod started to run hot. The mechanic employed on the establishment had exhausted his ingenuity and given it as his opinion that new bearings were wanted. We were rung up to give a figure for this and as a result inspected the faulty brasses. They were a heavy, well-made set (the journal was 8 inches diameter), they were not worn or damaged in any way and we could assign no reason for their failure. As it appeared to us to be folly to make new brasses when no defect could be dis-

covered in the old ones, we suggested that we make an examination of the engine. The brasses were scraped and the journal smoothed down and a red lead fit obtained. The lubricator was seen to and the engine started on castor oil. All went well for a while, but as soon as the load was put on trouble began. We went over this routine of refitting the brasses several times, as we found that when heated they had a tendency to close on the journal. To obviate this we shaped the edges of the brasses so that they

should bear on the outsides and thus any tendency to expand would cause them to open instead of close. Still the heating continued and at last we decided, as a means of calculating the pressure on the bearing, to indicate the engine. This decision saved us, for the indicator at once discovered an abnormally high initial pressure, due to pre-ignition, which was eventually traced to a faulty igniter. This was corrected and the bearing gradually cooled down, and has since given no further trouble."

GAS FOR POWER.

At a recent meeting in Glasgow of the Scottish Junior Gas Association, the President made the following remarks relative to power production:

The importance of the gas industry in affording an economical means of utilizing coal can not be urged too insistently in the present extravagant age. The rate at which our stock of coal is now being diminished is 220 million tons per annum, and is increasing. Many and differing computations have been made regarding the life of the coal-fields; but no doubt at all exists that a time will eventually come when these will be exhausted. That the welfare of the nation is closely bound up with the future of the coal-fields must be evident to all; for from this mineral is derived the energy, whether it be applied by steam, gas or electricity, which drives mills, propels ships, locomotives, and tram cars, lights and heats cities, and does the one thousand and one things which make life as we know it possible. Other sources of power in nature exist, such as water falls, winds, etc.; but none other is of so much practical importance—at least, in this country, although other lands, notably the United States of America and Switzerland, are more favorably situated with regard to water power.

Energy is obtained from coal chiefly by

means of the steam engine, the gas engine with coal gas, or the gas engine with producer gas. The steam engine, considered as a heat engine, is most uneconomical. Probably the average thermal efficiency of all steam driven plants in operation will not exceed 4 per cent. Of course, this figure is greatly exceeded in well-equipped central stations, such as those for the supply of electricity. Such stations will probably convert about 8 per cent of the heat of the coal into electric energy at the switch board, and that is all. There are no residuals of any kind; the remainder is lost—part having gone down the exhaust pipe, and part up the chimney to pollute the atmosphere. In the case of an electricity supply company, probably not more than about 7 per cent of the energy of the coal will be delivered as current to the consumer.

How different is the result where energy is obtained from coal by either of the other methods. In the manufacture of coal gas, about 20 per cent of the heat of the coal may be obtained as gas, about 47 per cent as coke, and, in addition, the crude residual products obtained have a value according to market fluctuations. Indeed, carbonization in closed chambers, such as gas retorts or coke ovens, with recovery of bye products, is a most economical process. The gas may be dis-

tributed in mains with very small loss; and if it be used for power purposes in a gas engine, 25 per cent of its heat may be converted into useful work.

With the gas producer, about 80 per cent of the heat of the coal may be converted into a combustible gas, and 25 per cent of this may be converted into brake horsepower in a gas engine. There are no bye products which may be recovered except sulphate of ammonia.

It will thus be seen that, so far as economy

in fuel is concerned, the steam driven plant is quite outclassed. In evidence given before the Royal Commission on Coal Supplies, Mr. Beilby estimates that if the average steam engine were entirely superseded, the 52 million tons of coal used annually for power purposes would be reduced to 11 million tons. From this it will be seen that, considered solely from the point of view of national economy in coal, the gas industry deserves well of the community by affording an economical means of utilizing coal.

ELECTRIC IGNITION APPLIED TO INTERNAL COMBUSTION MOTORS

On December 5, 1904, Sir Oliver Lodge, of Birmingham University, delivered a lecture on "Ignition as Applied to Internal Combustion Engines" before the Automobile and Cycle Engineers' Institute, in which he said that from the point of view of combustion a gaseous mixture, instead of a kind of spray, was the best and most rapid.

To achieve ignition the combustible mixture had first to be raised to a certain temperature, a critical temperature locally, and if it ever fell below that the flame expired. Ignition meant the raising of a small part of the mixture to such a temperature that combustion took place, and the remainder of the gas ignited by spreading. The necessary condition of this spreading was that other molecules susceptible of combustion should be within range of those previously fired, therefore it was necessary for the spreading of combustion that other molecules should be within such range, for there was a certain point beyond which ignition could not be spread. But supposing that between the combustible molecules there were inert ones, then of course the combustion would not spread unless some means were taken of bringing each combustible molecule within the sphere of influence of another. What would bring them into such sphere of influence? First of all, having more of them

in proportion to the nitrogen and other materials, and subsequently bringing active molecules into closer companionship by compression. Rarefaction prevented ignition from spreading and prevented explosion, but concentration and compression assisted it. But as the atoms were not stationary, but flew about, the disturbance if it lasted an appreciable time, would assist combustion, because the chances were that one or other of the combustible molecules would come within range of each other, and would be caught by the ignition and would spread it. As the molecules moved faster the higher the temperature, therefore temperature assisted combustion and explosion. Different gases possessed different rates of motion. For instance, atoms of hydrogen moved about four times as fast as the molecules of oxygen, so that any excess of hydrogen would assist combustion. It would be thought the exact chemical mixture would be the best for combustion, but this had been found not to be so, as the hydrogen being the lighter body, its atoms moved faster, and therefore the excess of that gas was preferable. Now the effect of diluting the mixture was just the same as rarefaction. He did not know if they knew of Dalton's law, namely, that every gas had a vacuum to enter, and that every one occu-

pied a space independent of the other; the one knowing nothing about the other as far as static distribution was concerned, so that the extra gas might mix with the combination as water mixed with sand, without disturbing the sand. So it was with gases; each kept the same distribution as before, as their molecules had different rates of motion, the lightest moving fastest, and the predominance of the lighter constituents favoring the spread of combustion. It might be asked if the presence of these foreign bodies made any difference in combustion. In some cases it did. Perhaps it made a difference to the sphere of influence. Dilution with other gases might have a retarding influence upon the combustion. It might possibly bring about a slowness of combustion. They might ask why some explosions were more violent than others, and why some were weaker? In the weaker explosion the combustible molecules probably went off on the meandering path spreading their combustion, and therefore the explosion would be slow, but with mixtures that were richer the molecules would be closer and more rapid explosion would ensue. If an increased rate of combustion was wanted with the poor mixture then they must compress it, and ignite it in several places. He then demonstrated by means of a Bunsen burner (the glass tube or burner conveying the combustible mixture being of considerable length) how the rate of combustion in a combustible mixture can be observed. The question whether it was better to ignite gas near the piston or near the base of the cylinder was sometimes put, and was a very proper question to put. It would be suggested that as one of the walls was running away, so to speak, and the ignition took place at or near the piston, the latter had time to move off, whilst that portion of the mixture farthest from it was in the act of being fired. He demonstrated his meaning by the analogy of a shell in a gun, thereby suggesting that ignition close to the piston

was the better, because the initial impulse would be given to it more quickly, and the combustion would not have to follow up the piston as it otherwise would have to do if the ignition took place in the crown of the combustion chamber.

In a slow-speed engine, a slow burning mixture might be used with advantage, because a more lasting blow, more of a push, was obtained. The walls of the gas engine were cold, and therefore they put out a flame in contact with them, hence you were bound to have a certain amount of combustible material unburnt. If only the walls of the cylinder were red hot better combustion would be obtained. It seemed absurd to work with the walls of a cylinder red hot, but he wondered if a century hence engineers would be satisfied with water-jacketing. He did not think water-jacketing was right, because it lowered the temperature at a place where it was wanted hot. If only you could let the air and gas into a hot vessel it would certainly be more economical. It did not seem beyond the province of invention to achieve that result. The only way that he saw hot material could be used was by some arrangement of a turbine, the Pelton wheel, which might be red hot. A gas engine on that plan might work. It might not be the most efficient way, and he did not pretend to solve the problem; he only said he never looked at this water-jacketing as the final solution. He thought better might be done.

He demonstrated his meaning with regard to the effect of hot and cold jackets upon combustion by passing a lighted taper between the cold coils of a small tube. While the tube remained cold the lighted end of the taper was extinguished, but so soon as the coil had been heated to a red heat the taper was kept alight when placed between them, thus showing how the combustion would be aided by the hot walls of a cylinder. In the ignition of explosive charges much advance had been made

The gun of today was not very different—in barrel, shot, shell, bullet or powder—from what it was centuries ago; but what was different was the mode of ignition. These arrangements had been altered, and these were the respect in which the modern rifle differed from the ancient gun. So it had been the case of the internal-combustion engine.

In referring to the various methods which had been employed in ignition, the speaker said that the tube method had the advantage of not opening to the air at all. If air were compressed sufficiently it became red hot, and if oil were injected into the hot air it would ignite it. A little spray injected into a highly compressed air was all that was wanted for its ignition, and this experiment was easily shown in a physical laboratory. Electric ignition might be regarded as almost a natural method of setting up combustion, because what was combustion after all? It was only electrical action. The force of chemical activity was electrical attraction at close quarters—an electrical attraction between molecules. What they worked at in a laboratory was visible chemical action at a distance. So combustion was an electrical process.

Self-induction was not by any means thoroughly understood. It might really be called electric inertia. It used not to be known that electricity possessed any inertia, but it did, and to start an electrical current was very much like starting a barge on a canal, taking a little time to get up speed. When the electric current was steady it was because the propelling force and the resistance were equal, and so the electricity was

moving by reason of its own inertia obeying the first law of motion.

The inertia of a circuit depended upon, and was proportionate to, the amount of magnetism. They would have a lot of inertia with a good current, and the best way of stopping it, if required, would be to take a little time over it and use a little gentle force. Put an obstacle in the way and the obstacle would get smashed. There were many ways of stopping a current with inertia. One was to put a film of air into the path. If a film of air were put into the current it would be smashed by the inertia of the current trying to get through it. That was called self-induction. The more suddenly one put a film of non-conducting air in the way the more violent would the spark be. He saw in a journal that there was being brought out a cam with a spring which released suddenly, in the case of weight contact; this might possibly be a good plan.

The speaker introduced his own improved method of ignition, which differs from the present high tension system by coil, in that instead of the high tension current from the coil being taken direct to the plugs it is taken to Leyden jars, and the tertiary induced current from the outer coats alone being conducted to the plugs. The Leyden jar, or condenser, acts in a way analogous to a spring and stores up the current gradually, and throws it out again with violence. As a result of this system plugs were shown sparking in oil and in water, and generally reversing the normal ideas which at present prevail as to their treatment when fitted in the usual gasoline motor.

BOOK REVIEW.

Dry Batteries—By a dry battery expert. 59 pp., 5x7¼, paper. Price 25 cents.

This book gives detailed instructions for the manufacture of dry cells of any shape and size, especially adapted for automobile,

launch and gas engine work. It is written "by a dry battery expert," who is said to have made every kind of cell, and Norman H. Schneider (H. S. Norrie) has furnished additional notes and 30 original illustrations.

CORRESPONDENCE

Editor The Gas Engine:

We have been doing some wood sawing that beats anything we have heard of in that line, and think it might be of interest to your readers to know what can be done with a gasoline engine of small power.

If any of your readers have beaten this record, we would like to hear of it, not that we wish to challenge them to a wood-sawing contest, but because we would like to know what others are doing in our lines of work.

Our rig is a 6 H.P. engine with a 36-inch saw mounted on a truck. We use a magneto with governing pulley for igniting, and with this we start without a battery. We keep an eight-cell dry battery at home for emergencies, but rarely have use for it.

We use a small water tank and about ten to fifteen gallons of water with a small circulating pump for cooling the engine. We can run all day without changing the water, and in cold weather we drain it all out at night, and avoid all trouble of freezing, and have only four to six pails of water to put in in the morning.

During the winter of 1902-'03 we used a 4 H.P. engine with a 36-inch saw, but in 1903 we sold that rig and bought a 6 H.P. engine and 36-inch saw.

In the winter of 1902-'03 with the 4 H.P. engine and 36-inch saw, on the farm of Mr. John Garland, Coal Valley, Ill., we sawed inside of four hours, a pile of pole wood which measured an equivalent to 32 feet long and 5 feet high. The length of the poles running from 10 to 18 feet, and up to 15 inches in diameter. This was all cut in 16-inch lengths.

During the winter of 1903-'04, with our 6 H.P. engine and 36-inch saw, on the farm of Mr. Peter Leaf, Coal Valley, Ill., we sawed in six and one-half hours forty

cords of pole wood, 128 cubic feet to the cord, all cut in 16-inch lengths. In this job the poles were in three piles, so we had to move twice.

During the same winter with the same rig, on the farm of Mr. Wm. Brown, Coal Valley, Ill., we sawed in five hours fifteen cords of cordwood in 16-inch lengths and sixteen loads of pole wood in 16-inch lengths. We did not get the measurement of the pole wood, but there must have been at least fourteen cords.

Two of us go with the rig and change off feeding every fifteen minutes. We use from five to six gallons of gasoline a day.

With the same engine we also run a two-roll Cyclone shredder, with blower attachment, to its full capacity with ease. Also a hay press, baling sixty bales of hay per hour, which is not load enough to interest the engine at all.

Should any of your readers wish to satisfy themselves as to these records, let them write to the men for whom we did the work.

It is a mistake to think it necessary to have an 8 or 10 H.P. engine with which to saw wood. We have no trouble at all in starting our engine in the coldest weather.

During the fall of 1904 we had a job of building a stone arch over a small stream near us. We used our well-drilling machine and the 6 H.P. engine as a hoist, and rigged up a derrick with a couple of strong poles and some rope. We could easily handle and put in place stone blocks 2 feet by 2 feet by 5 feet.

We also own a steam portable engine, but our light gasoline rig beats that all to death. Our engine weighs but 1,040 pounds, making it extremely handy for all kinds of work. Yours very truly,

Orion, Ill

Nicely & Jones.

WINDMILLS AND GAS ENGINES

The Bureau of Statistics, Department of Commerce and Labor, has issued a special consular report relative to windmills in foreign countries. While intended to cover more particularly the possibilities in the use of American-made windmills, several of the consuls indicate that the gas engine is established in their districts. U. S. Consul Wallace, at Crefeld, Germany, says that windmills are in use in his district and that the only dissatisfaction he heard expressed by the owners or operators of these windmills was because of the uncertainty of the wind, and to remedy this defect a few of the mills were being provided with small engines of 25 or 30 H.P., for use in times of extended calms, which last sometimes over a period of two weeks, in which there will not be sufficient wind to furnish the necessary power to operate the machinery.

He adds that a small gasoline engine would fit the wants and conditions of the little mills for occasional use during calms.

They could be attached at so little cost and the addition would be of so much advantage that sales of such engines should be readily made.

The consul at Mannheim, Germany, states that a 2-H.P. gasoline engine has been installed in his district to keep the windmill going during calm weather.

Oil, gas and gasoline engines are mentioned as being in use in the Transvaal colony; Ciudad Juarez, Mexico; Kingston, Jamaica; Marseilles, France; Bergen, Norway; Lisbon, Portugal, and Barcelona, Spain.

At Melbourne, Victoria, the consul states that oil engine pumping plants are being used invariably on the large cattle ranches, orchards, etc. In Syria windmills have been tried, but petroleum engines have given better satisfaction. The consul at Winnipeg, Manitoba, states that in the wheat-growing section gasoline engines will probably grow in favor.

SOME SUGGESTIONS TO SPARK PLUG USERS

The R. E. Hardy Co., 225 West Broadway, New York City, have issued a folder giving suggestions to spark plug users, from which we quote the following:

In all forms of gasoline internal combustion engines employing jump spark ignition, the most difficult and severe duty falls upon the spark plug, which must resist three hundred and fifty pounds pressure per square inch, must stand a high temperature (it is exposed to flame under pressure at a temperature of 3,000 deg.) and in addition it must perfectly insulate a high pressure electric current of from 10,000 to 25,000 volts. It is exposed to deposits of carbon which tend to allow the spark to escape by

providing a path for it to go where the combustible gas cannot get to it. Thus causing misfires or total stoppage of motor. The spark plug is thus seen to be the most important part of the machine, and also the part which most needs to be thoroughly understood and carefully handled.

In case of failure to ignite at all, the first thing to inspect is your coil, see that vibrator works when circuit is on, next remove wire from top of plug, hold it $\frac{1}{4}$ inch from metal parts and observe if spark will jump the gap. It must be capable of jumping at least six times the space of gap between spark points inside, as the resistance of hot gas under pressure is much greater than

free air. If spark is weak a new battery or coil is required; but if this cannot be supplied at once a plug having shorter spark gap may be made to work, or the one in hand may have gap shortened by turning bolt inside of porcelain (first removing cap and loosening nut) till best position is found. The best distance for most circumstances is 1-32 inch, but with weak battery better results may be secured by a shorter gap. While with strong spark capable of jumping greater resistance a more certain ignition is secured by having a somewhat wider gap; it all depends on the power of coil and battery what width is best, and you should never make changes unless sure that you have extra plugs with you, or are certain

that you know what the result will be. If the spark is good the plug should next be removed and inspected for carbon deposit, or cracks in insulation. Carbon deposit will not take place unless you are feeding too much oil, or burning more gasoline than can be completely consumed. If carbonized the deposit may be washed out with gasoline or kerosene and a small sliver of wood. If tube is cracked or broken a new one must be inserted. If sparking end of plug appears all right the next thing is to remove nuts and cap from top of plug, and see if it is wet or coated with carbon inside. If wet it must be wiped dry and replaced; if black it must be cleared and a new packing inserted.

TWO IGNITION TIMERS

"Two Leading American Products" is the title of a circular received from C. L. Altemus & Co., The Bourse, Philadelphia, Pa. The front page contains a half-tone of "The American Girl," and also of the "Altemus Timer," the products referred to by the title. This timer does away with more than one coil in multi-cylinder engines, saves trouble from possible defective wiring of many coils. It occupies a space of but 3 by 2¾ inches.

This device consists of a polished, hard rubber case with removable glass front,

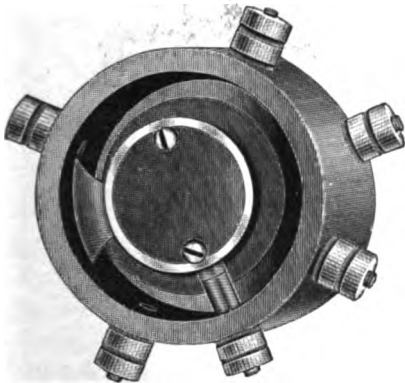

The Altemus Distributor

with full one-inch bearings, lubricated by means of a compression grease cup. It contains a bronze disc, from which extend the primary contacts of tool steel. Throughout one revolution these points pass over and connect with a push pin set in the rubber casing, and wired direct to one of the primary posts of the coil. In this manner the primary circuit is opened and closed. Fastened to the primary disc is another disc of hard rubber, from which extends a core, having on its periphery a brass ring, against which is a brush connected to the secondary current. Projecting radially from this ring is another small arm, which passes over the heads of the plug terminals set equi-distant apart in the rubber casing. Since this arm does not touch either the terminal heads or the rubber casing, there is no wear whatever on arm or contact points.

The commutator is geared to the main shaft of a two-cycle engine or fastened to the cam shaft of a four-cycle engine, by means of which the primary and secondary discs above described are rotated.

The primary contact is so placed that it will engage just about when it is desired that a spark shall be produced in any particular cylinder, the secondary arm being already in position to distribute the

high tension current to the proper plug terminal. It will, therefore, be seen that the circuit of a primary winding of an induction coil is completed after the completion of the circuit of the secondary winding of said coil, so that a spark is caused to pass between the terminals in the desired cylinder at any predetermined time.

By means of a lever the spark may be advanced or retarded in all cylinders simultaneously.

The "Bowles" primary timer is also a product of this company, which is made for engines with from one to four cylinders. The contact points in this timer are hardened steel with quick snap away, but no hammer blow, each point having special spiral push spring.

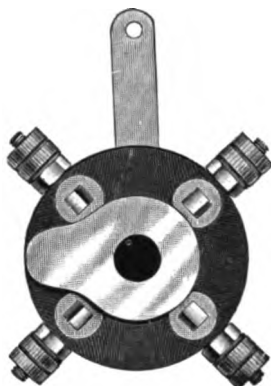

The Bowles Timer.

THE GOODSON IGNITION SYSTEM

The Goodson igniter is an electric generator of the magneto type, provided with a spring impelling device, connected to a crank on the armature whereby the armature is made to rotate within the magnetic field for a portion of a revolution at a speed which is entirely independent of the speed of the engine, and which is sufficient to generate the required current to produce a good spark. The igniter is connected directly to the engine shaft by a sprocket wheel, and is so arranged that as the shaft turns it puts the spring impelling device under tension, and is so timed with reference to the position of the piston that the spring impelling device is tripped into action at the proper time, giving the armature a quick impulse and producing the spark. It is so constructed on a rocking base that the time of the ignition can be varied at will, while the engine is in motion.

One of the features of this system is the magnetic spark plug. It consists of an or-

pair of electrodes, inserted in a cast iron body, which is screwed directly into the cylinder head or ignition chamber of the engine. When the impulse of electricity energizes the electro magnet, the armature is attracted and brought rapidly against the



cores of the magnet. This causes the movable electrode to separate from the stationary one, thus breaking the circuit and producing a spark. A little spring attached to the armature closes the electrodes, when it is ready for another impulse of current.

Rust, carbonized matter or oil have no effect whatever on the points. When all

three conditions are encountered, an equally good spark is obtained as with clean points. A metal cap fitted over the the plug protects the magnets, etc., from dirt, oil, moisture or accidental striking.

The Goodson ignition system is guaranteed to produce a sufficient spark to start a gas or gasoline engine without the use of batteries or spark coil. The usual

guarantee against defective parts is also made.

The manufacturers of the system are the Goodson Electric Ignition Co., Providence, R. I., who state that the Fairbanks Co., of New York City, and the Ruggles Machine Co., of Poultney, Vt., have adopted the system as the standard equipment for engines made by them.

GASOLINE AND WATER SEPARATOR

It is a well-known fact that all gasoline has more or less water in it. This may come from the process of manufacture, transportation, snow or rain, and sometimes it gets in through the elasticity of the retailer's conscience, but, however it may get there, it is a great source of annoyance and responsible for no little profanity.

As may be easily observed, gasoline floats on water by reason of the difference in specific gravity, and in settling to the bottom of a tank, often forms a cake of ice during a cold night, or settling to the lowest point of the piping it has been known to freeze and burst the supply pipe. It can also be easily shown that the presence of even a small percentage of water in the gasoline interferes decidedly with the working of the engine, when this water is fed through the same valve or carbureter as the gasoline, and often causes serious delays from stoppages without an apparent cause, and a positive refusal to start again.

This trouble makes itself felt just as the supply tank is nearly empty, and often you will hear the operator say that his gasoline was no good, and he had to throw it away and get new, while the true cause of his trouble was the water mixed with the gasoline, and his engine is built to run on the latter, rather than on the former. It is true that water may be fed into the intake pipe of a gasoline engine,

between the mixing valve and the cylinder, if fed in small and regular quantities, forming a ready means of internal cooling, and resulting, some claim, in improved economy of gasoline, but this is a very different matter from feeding the gasoline to the engine mixed with water, since the succession of even a few drops of water passing through the mixing valve will result in the loss of impulses, and so weaken the engine that a stoppage is the result.

Heretofore there has been nothing to overcome this difficulty, short of drawing off the greater part of the barrel of gasoline from the top and throwing away of remainder at no little loss. The Eureka separator, which was especially designed to overcome this trouble, has proved during six months' practical test to be fully equal to doing the work intended, and the manufacturers now feel confident in offering it to the trade as the best and only separator that will take the water out of gasoline, so that it can be drained off by the means provided. It is an extremely simple device, light and small, and has no moving parts, except the drain cock. The supply pipe from tank is connected at the bottom of the separator, while the delivery pipe leading to the engine is connected at the top, thereby permitting the flow of gasoline, the passageway leading to this pipe extends far enough below the level of the

gasoline to provide an air or vapor cushion in the chamber above the level of the gasoline, resulting in a uniform pressure of the oil at the needle valve or carbureter, greatly improving its working.

The arrangement of the lower part does not permit the incoming gasoline to stir up or agitate the separated water,

which lies quietly in a pocket by itself. The separating material is placed in the center of the device, which can be easily taken apart for examination if necessary. These separators are made in three sizes, and can be had of the leading supply dealers or direct from the Eureka Separator Co., of Rockford, Ill

ELECTRIC LIGHT OUTFITS

Through the misplacing of linotype lines in the article on page 11 of our January issue, several paragraphs appeared rather mixed. The outfits, consisting of engine, generator and necessary accessories, furnished by the Richardson Engineering Co., of Hartford, Conn., are supplied with a suitable storage battery. In the marine type the elements are assembled in rubber jars, which are provided with tight-fitting covers to prevent spilling of the acids.

The stationary battery outfit is not sealed, as this is unnecessary. A third type is the 40 ampere hour stationary battery, which consists of but two plates to each cell, a positive plate of one cell being joined to the negative plate of the next with solid straps, doing away with all bolt connections.

The storage battery is a very desirable element of a small isolated electric light plant. Obviously it will often be undesirable, if not impossible, to keep an engine and dynamo in constant operation ready to supply current at such times throughout the 24 hours when light may be required. Such a proceeding would necessitate duplicate machinery and a double shift of labor, an expense not warranted by the results. The ability to make the plant furnish light at any time during the 24 hours is, however, readily attained by the addition of an accumulator, or storage battery to the outfit. Take for example the No. 3 outfit. This plant will furnish

current for 20-16 c. p. lamps, but even if the house be wired for this number, it is not likely that over six lamps will be burning at one time. The cost of operating the plant, however, is nearly as great under the conditions as it would be if the full number of lights were burning. In other words, a capacity equal to 14 lights may be stored in the battery with but little additional cost. With a battery of proper capacity, the engine may be operated at the most convenient period in the 24 hours, irrespective of whether this period occurs when the lights are wanted or not. Often times where the demand for light is small, as in summer, when the days are long, the engine will very likely not be required to operate more than once a week. It follows, of course, that if on some special occasion it is desirable to have burning more lights than the dynamo and engine can furnish, the battery acts as an enlarger of the plant, since it can be filled earlier in the day, and helps the dynamo carry the load when necessary. The battery may be connected to the lighting system all the time, so that if late at night one or two lights are required for emergency, it will not be necessary to resort to the old kerosene lamp.

In addition to furnishing outfits for small lighting plants, the manufacturers state that they are able to furnish plants up to 1,500 light capacity. These may be furnished with or without the storage battery feature.

ANSWERS TO INQUIRIES

It is our purpose to answer in this column inquiries of general interest which relate to the gas engine or its accessories. The questions will be answered in these columns only, and we reserve the privilege of refusing to answer any question which is not, in our judgment, of interest to the subscribers of THE GAS ENGINE.

All matter intended for this department should be addressed to The Editor of THE GAS ENGINE, Blymyer Building, Cincinnati, Ohio. The name and address of the sender must accompany the inquiry in all cases as evidence of good faith. The initials only of the sender will be published, together with the postoffice and state.

Write on one side of the paper only, and make all sketches and drawings on a separate sheet. Mark each sheet with the name and the address of the sender.

(a) At what temperature F. may kerosene be converted into gas and used in place of gasoline? (b) In a two-cylinder gas engine, how should the cranks be located for best results?

C. W. T., Chicago, Ill.

(a) Kerosene vaporizes at from 300 to 575 deg. F. It is not, however, necessary to bring the kerosene up to this temperature for use in the engine. After an engine has got hot by starting on gasoline it will usually run successfully on kerosene, and even some of the other distillates. Ordinarily kerosene engines draw in the air from around the exhaust pipe or air shaft surrounded by hot water from the engine. (b) In a four-cycle engine the cranks should be both on the same side of the crank shaft. In the two-cycle engine at 180 deg.

As I am a subscriber of your magazine, I am taking the liberty to write you for some information in regard to concrete foundations for gas engines from 100 H.P. Please give me the proportions of Portland cement, sand and broken stone, and also what effect freezing weather would have on the concrete, and also state

what effect salt would have if it is used in the mixing of the concrete.

J. H. E., Ridgway, Pa.

The usual proportions for Portland cement are to one of the cement, two of ground sharp sand and five parts of gravel or broken stone. Concrete must not be laid without salt in freezing weather. Salt is used a great deal in laying of concrete in winter to the amount of about 5% of the water used, however, it is not best to use salt if it can be avoided, as it does not in any way strengthen the concrete and its hygroscopic action tends to keep the foundation damp in wet weather.

On page 125 of your "Gas Engine Handbook" formula (6) reads

$$R = \frac{380}{(H) .21}$$

This, I presume, could not be used for automobile engines. For example, let H=6, then R becomes 268, which would be entirely too small for an automobile

Can you tell me what constants might be used for automobile engines instead of 380 and .21?

A. W. L., West Duluth, Minn.

Instead of using this formula it is best to take the speed of the piston at 800 feet per minute. The piston speed being twice the stroke in inches multiplied by the r.p.m., and divided by 12.

(a) I am designing a two-cylinder vertical gas engine to develop 100 H.P., what should be the bore, stroke, revolutions, diameter of crank shaft, length of main bearings, and weight and diameter of flywheel? (b) In case a third cylinder were added, making engine 150 H.P., what then should diameter of crank shaft be, and what changes should be made in flywheel? (c) What changes in these details are necessary when engine is used

on producer gas? (d) What advantage in an engine of this size has a small bore and long stroke over an equal bore and stroke?

W. E. M., Elizabeth, N. J.

(a) We should recommend 14½-inch by 18-inch at 235 r. p. m., crank shaft 5¼-inch diameter, main bearings 10½-inch long, diameter of flywheel 72-inch, weight of rim 1,775 pounds for electric light work. (b) The same diameter of crank shaft holds in this case. The flywheel may be one-third lighter. (c) This bore and stroke will give about three-fourths as much on producer gas as on natural gas or gasoline. As the flywheel is proportioned to the indicated H.P. this could be made smaller in proportion, also on account of the smaller initial and mean effective pressure the crank shaft and bearings need not be so large. Theoretically the best efficiency is given when the stroke is 1½ times the bore.

(a) We have a 6½-inch by 9-inch four-cycle engine running at 250 r. p. m. which the makers claimed to be 5 H.P., but from which we can get only 15 amperes with a dynamo whose fields take one ampere, from which we figure the engine develops only 2½ H.P. (b) Please state what should be the diameter of each valve and also their lift? (c) What should be the dimensions of the compression space?

What would be the result if we bolted a plate ½-inch thick on the back of the piston? Would it endanger the crank shaft by reason of increased compression and greater velocity?

A. M. H., Erie, Pa.

(a) Not knowing the voltage which is given off by your dynamo we can not tell you whether your figures are right or not, but it must be remembered that the efficiency of a small dynamo is very low indeed, quite often being but 50%. In this case your engine would be developing the full power claimed for it, but it will not give much over 5½ H.P. on

natural gas, and is doing fairly well if it gives 5 H.P. (b) According to your figures the valves should be 1 11-16-inch diameter for the inlet and 1 ⅛-inch diameter for the exhaust. The valve lift should be ¼ the diameter. (c) The compression space should contain 90 cubic inches, but not knowing the exact shape of your cylinder from the sketch submitted nor the volume of the valve chamber we can not tell you just exactly what the length should be. (d) Bolting on a ½-inch plate would increase the initial pressure, and unless your crank shaft is unusually strong it may twist it or break your connecting rod. We think the best way for you to tell what your engine is doing is to make a brake test with a prony brake. If it does not develop 5 H.P. there is a deficiency somewhere.

Please give the size of ports in a two-cycle 5 x 5 in. Also the compression space necessary to get the best results. Is it possible to run a two-cycle engine 1,200 r.p.m. without a skip or miss?

For a high-speed engine the inlet and exhaust port should each be 2 ⅝-inch around the cylinder and the exhaust port should measure 15-16-inch in the direction of the stroke and the inlet port ⅝-inch. The bottom of the port should be even with the top of the piston, when the latter is at the bottom of its stroke. The compression should be about 85 pounds per square inch, and the compression space 29% of the piston displacement. If the engine is made of the three-port type with compensating vaporizer it may be run at even a higher speed than 1,200 r. p. m.

Would you kindly state through your next issue of THE GAS ENGINE if 1-inch piping is large enough for a 4-inch by 5-inch gas engine running 600 revolutions and would it do at 900 revolutions? The

valves have a $1\frac{3}{8}$ -inch opening. I refer to the intake pipe above. The exhaust has a $1\frac{1}{4}$ -inch pipe.

J. B. W., Kenosha, Wis.

A 1-inch inlet and a $1\frac{1}{4}$ -inch exhaust piping are large enough for 600 r. p. m., but for 900 r. p. m. both pipes should be $1\frac{1}{2}$ -inch.

Will you kindly inform me by what means indicator cards are taken in the largest gas engines, and how high the measured pressures run?

G. W. L., Washington, D. C.

Indicator cards for large gas engines are taken by means of an indicator like the ordinary steam engine indicator, but with a $\frac{1}{4}$ -inch area piston and a specially heavy pencil movement. Practically all indicator manufacturers make gas engine indicators. The pressure runs as high as 400 to 450 pounds for the maximum initial pressure.

Will a kerosene engine with automatic ignition, such as hot heads, chambers or tubes, run smoothly under the following conditions: For example, if the engine is a 50 H.P. and the fuel valve is set so that the engine runs smoothly and evenly when under full load, then if all the load but about 5 H.P. be thrown off, will they run as smoothly on this light load and continue so for probably an hour or more without making any change whatever with the fuel valve or paying any attention whatever to the engine? I should think the cylinder head would cool off on continued light load and affect the timing of the ignition, thus requiring a richer charge, necessitating a change of the fuel valve or the pump regulating the charge so small as to be very lean in mixture. (b) Would not electric ignition be more satisfactory? (c) Also, can kerosene be vaporized satisfactorily by induction into the cylinder, being vaporized by the cur-

rent of air drawn in? This to be done without hot heads, chambers or heat of any part of cylinder or exhaust. Would this give a good mixture? I have always been under the impression that kerosene would not vaporize satisfactorily without the aid of heat, such as hot heads or heat from the exhaust. I have lately heard of an engine having an electric spark and a mechanical vaporizer by suction running with kerosene. (d) Would not a gasoline engine run smoother and govern better under light loads, having a hit and miss governor holding the exhaust open, rather than one which only lets the fuel valve stay closed, allowing the cylinder to scavenge, thereby changing the condition of the mixture of the next charge? These questions are some derived from conditions which occur in a stone polishing plant which we run by gasoline engine.

W. N. M., Quincy, Mass.

(a) The engines you refer to do not as a rule run smoothly on light load for exactly the reasons you mention. (b) Electric ignition has been used successfully in quite a number of kerosene engines. (c) Usually some method of heating the kerosene or the air before entering the engine is employed, such as drawing the air from around the hot exhaust pipe. (d) So long as the fuel valve is closed absolutely we do not believe there will be a great deal of difference in the operation of the engines. However, if there is a slight leak in the fuel valve there is apt to be an overcharge of fuel when running by cutting off the fuel instead of when holding the exhaust valve open.

(a) With a propeller large enough to overload a two-cycle engine until its r. p. m. were four-fifth of what it should be, could a second engine (duplicate) be coupled direct and still not have too much power for the same propeller? (b) Would the crank shaft of the "aft" engine

need to be heavier than necessary for its regular work or would it do? (c) If the crank shaft were strong enough, is the idea of "direct connecting" two 2 H.P. two-cycle engines practical? (d) Would this differ essentially from a double cylinder engine? Tandem.

(a) We believe that the propeller would run one-third faster with the second cylinder. We do not believe it will have too much power. (b) No, the same size crank shaft will answer. (c-d) The scheme is perfectly practical and would not differ essentially from a double cylinder engine.

(a) In a 5x6 two-cycle marine engine, at what point should I place pet cock for relieving compression in starting? (b) What is lowest compression that will give an explosion?

C. A. K., Saginaw, Mich.

(a) Place cock at half stroke. (b) Explosions will occur at atmospheric pressure.

In calculating the weight for the rim of the flywheel suitable for a 6 H.P. gasoline automobile engine I am having considerable trouble in getting a rational answer. Will you kindly show me how

it is figured? The data I use is as follows: H.P.—6. Diameter at center of gravity of rim—12.75. Speed—1,200 r. p. m. Coefficient of unsteadiness—.335 Using the formula No. 22, page 163, of the "Handbook," the result obtained is 7 pounds, which is obviously wrong. Will you kindly show me where I have made a mistake and the proper way of calculating this?

The discrepancy in your results is due to first, using what is evidently the B.H.P. of the engine for the I.H.P., and the maximum speed of the engine instead of its lowest speed. In absence of cylinder dimensions, we will assume the mechanical efficiency of the engine to be 75%. Then the I.H.P.—8. Then take the lowest speed at which the engine should run giving its full impulse. This will be when climbing grades on high gear with the throttle wide open, and assuming it to be 300 r. p. m. the formula becomes, substituting this figure, and $\frac{1}{4}$ the I.H.P., as the engine runs at $\frac{1}{4}$ speed.

$$\frac{2 \times 111,600,000,000}{(12.75)^2 \times (300)^3 \times .335} = 152 \text{ lbs.}$$

If there are to be two wheels make each with 76-pound rims.

TESTS FROM FOREIGN EXCHANGES

At Puteaux, France, a suction gas producer supplies service to eight Crossley gas engines, the total capacity being 300 H.P. In a test of the plant 27,000 cubic feet of gas was produced per hour. The temperature of the gas on leaving the producer was 874 deg. Fahr.; on leaving the cooler, 464 deg.; in the scrubber, 81 deg., and in the purifier, 79 deg.

At Wolverhampton, England, a 12 H.P. gas engine was run 76½ hours, consuming 23,054 cubic feet of coal gas, at a cost of 50c per 1,000 cubic feet, amount-

ed to \$11.53. An electric motor was then used to drive the same load, for the same time, and the cost of current amounted to \$20.02, showing a saving of the gas engine of \$8.49. The motor had been built specially for the test, while the gas engine had been in use eight years.

A gas producer plant at Calcutta, operating with gas coke of 12,411 B.T.U. for fuel, showed 1.325 pounds of fuel per kw. hour, or .92 pound per B.H.P. hour.

Two four-cylinder, vertical, four-cycle engines of 300 H.P. each, on producer gas

from anthracite pea coal in England showed 1.48 pound of coal per kw. hour in the producer and 1.67 pound in the producer and accessory boiler used for raising necessary steam.

A 250 H.P. German gas producer plant, with a double-acting gas engine; recently

tested .744 pound of coal per B.H.P. hour, the coal showing 14,600 B.T.U. per pound. The producer consumed 140 pounds of water per hour, the scrubbers 3,186 pounds; the cooling water in the piston was 17.6 pounds per B.H.P. hour. The gas left the scrubber at 338 deg. F.

FARM USE OF GASOLINE ENGINES.

I purchased some time ago a 3 H. P. engine, a silage cutter and a twenty-three-foot elevator. The silo being in one corner of the barn right beside the door, I built an ell 10 x 23 feet beside the driveway to the barn and put my cutter and carrier in it. Having a large door opposite the cutter, I could drive a load up alongside and take from the load to the cutter.

This makes filling the silo very simple and easy. I also bought a steel frame saw bench and saw and when wood-cutting time comes I removed the cutter and put the saw in its place. I haul my wood directly to the saw and when it is all hauled it is all sawed. After this is done I can load my

machine onto a sled and go out and cut about 125 cords for my neighbors. When I return home I can put a rip saw in the place of the wood saw and use it

I propose to buy a feed grinder and do my own grinding. Another plan is to build an ell on the other side of the driveway parallel with the cutting room and have a dairy room and icehouse in it, running a shaft across the roadway under ground. This will enable me to cut silage, saw wood, rip boards, grind feed, separate milk and churn with the power practically stationary. These are some of the possibilities of the gasoline engine.—C. L. Wyman, in *Homestead*.

GAS ENGINES FOR WARSHIPS.

The German navy officials at Berlin are giving close study to the possibilities of gas engines for propelling warships. The Admiralty is having a large vessel fitted out for experiments. A discussion on the subject attracted unusual attention at a recent session of the German Society of Naval Architects. The chief paper was read by Engineer Capitaine, of Frankfort-on-the-Maine, who predicted that gas will displace the present steam engines, as well as the turbines.

According to the engineer's calculations the present machines utilize only 12 to 14 per cent of the coal's energy, whereas gas engines utilize 26 per cent. The speaker

described his invention, which he copiously illustrated by models and magic lantern pictures, whereby he proved that gas can be successfully adapted to driving marine engines.

The Thornycrofts are now building a vessel to be fitted with a 100 H. P. gas engine, according to the German engineer's plans. The latter doubts whether the existing types of gas machines are available to above 1,000 H. P., but he says his invention solves the problem for larger sizes.

The merits of the new machine, besides doubling the energy from coal, will be a great saving in room and in weight.

—*Cincinnati Enquirer*.

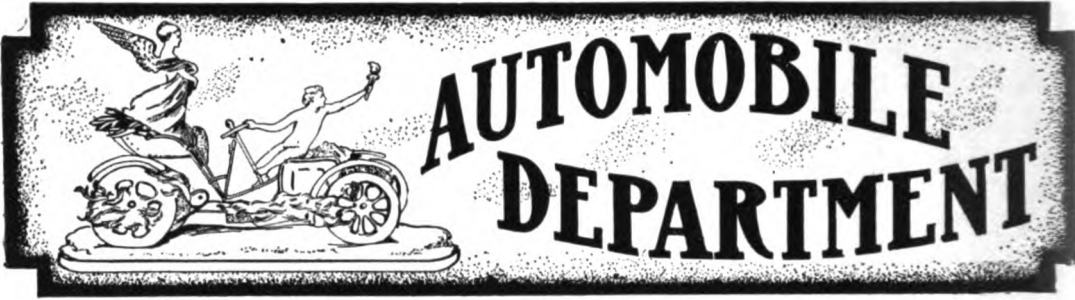

Although we have on several occasions published articles on repairing cracked water jackets, we frequently receive inquiries from new subscribers as to how it may be done, and therefore repeat the information.

The best way to try and stop up a leaking water jacket is to make up a strong solution of sal ammoniac with boiling water. Pour this into the jacket when the outlet holes in the jacket have been stopped up, and allow to stand for a day, or longer is necessary.

This can be done for a small leak, and a larger one may be stopped by taking a chisel and cutting a V along the line of the crack, which may then be calked and a piece of soft copper well worked into the V, which will often do the work.

Another way is to fit a piece of steel plate over the crack so that tapping holes can be drilled round the crack outside it, then a piece of steam joint rubber can be used to pack between the plate and jacket, and 3-16-in. or ¼-in. set screws hold it together and make a satisfactory joint.

At the last meeting of the American Society of Mechanical Engineers, Mr. Sanford A. Moss read a paper on the influence of the connecting rod on the engine forces. He gave a method of taking into account the influence of the weight and inertia of the connecting rod upon the forces transmitted by the ordinary mechanism of steam and gas engines. He con-

sidered the connecting rod as partly a rotating part concentrated at the crank pin, and partly a reciprocating part concentrated at the crosshead pin, and by mathematical analysis determined the proportion of the weight of the rod which is to be taken as representing each part. He found that a division of the weight of the rod by two very closely represented the correct division. The proportion of the rod which he considered to be essentially a rotating member he balanced by introducing a weight opposite the crank pin which should have the same centrifugal force, this weight being additional to that required for balancing the crank and crank pin. The other half of the rod he added to the weight of the reciprocating parts in order to determine the counterbalance necessary to offset the effect of those parts. At the conclusion of his paper he discussed the effect of the direct weight of the rod as distinguished from its inertia effect, this discussion being general and applying to cylinders of all angles of inclination to the horizontal.

The Northern Illinois Telephone Co. employs motor cycles for its "trouble hunters." The motor cycle carries the rider's spurs, dry batteries, wire and other appliances he may need in making repairs to the lines. The fuel cost is about 25 cents a day. One man now does the repair work formerly done by three men, and at the same time saves \$9 per day over the expense of maintaining horse-driven vehicles for the work.

THE SHOW MECHANICALLY CONSIDERED

By E. W. ROBERTS.

I had really hoped to see some approach to standard construction this year, but the outlook is worse this year than it was last. When you see the manufacturers who stand at the head of the list in output, make an entire change of model and mechanism each season, and this year more radical than ever before, the adoption of one general type as in the locomotive is seemingly very far in the future. For example, this year's show marks the adoption by a large number of builders of the four-cylinder vertical engine. Note Winton, Stearns, Cadillac, Autocar and many others who have heretofore built horizontal engines and most of them under the body. This radical change brings forth a question, Why is it done? The answer is simple. The public is learning to choose and knows more about the advantages of the various types. With all respect to those who still cling to the horizontal engine many of whose cars are excellent, I must say that the preference for a vertical engine under a hood at the front of the car is well justified. No matter how accessible by lifting the floor or the body, much of the work on a horizontal engine must be done when lying on your back in the road with the oil dripping in your face. True much of this is avoided when a horizontal engine is placed under the hood. The tendency this year is toward the shaft drive and the abandonment of the chain. This is just the opposite of the practice of the foreign cars as shown at the importers' show where with one or two exceptions all the cars had the double-chain drive. The double-chain drive avoids the use of the divided axle since the wheels run on the end of a stationary axle just as do the wheels of a wagon. On the other hand, the shaft drive may be entirely enclosed

and the gears and their accompanying parts run in oil. By careful design and construction there is nothing to prevent the cage and the tubes of the shaft drive being made as still as the axle in the double-chain drive. Under the very best conditions, the chain has a slight advantage over the bevel gear in efficiency, but under operating conditions, where the chain is dirty and the shaft and gear run in oil, the shaft drive has a decided advantage over the chain.

What is quite new in this year's practice is the enclosed intermediate shaft on machines using the bevel gear. This usually consists of a tube which keeps dust from both the driving gears and the universal joints. While at least one of the large builders, the Locomobile Co., is using plain bearings, the roller and the ball bearing seem to be losing but little in popularity, and in the Hotchkiss car exhibited at the importer's salon, the engine has ball crank shaft bearings.

One point that is worthy of note more than any other, is almost entire disappearance of the suction inlet, on large cars and small. The arrangement of the valves in the majority of the four-cylinder engines is on opposite sides of the cylinder head, using what is called the T-head construction. A few have the valves on the same side of the cylinder in order that one camshaft may be employed, while several engines have the valves placed in the top of the head opening directly into the compression space. Whatever the disadvantages of this construction, it has invariably been found that placing the valves in this position has resulted in materially increasing the power of the engine. In fact, one manufacturer told me last summer that he could get nearly 25 per cent more power by placing his valves

in this position. Much of the difficulty of operating valves in this position disappears when the camshaft is placed on the cylinder head either at the side or the top and operated by bevel gears through an intermediate shaft.

The sliding gear is used on at least 50 per cent of the cars exhibited, the planetary and the individual clutch systems dividing the honors for second place. Whatever may be said against the sliding gear, it is certainly positive and saves a multiplicity of clutches. In general the type of sliding gear transmission is one that gives a direct drive on the high gear with no gears in action. The tendency is also toward the adoption of a gear in which any ratio may be picked up without passing through any other. There is also a tendency to return to the selective system for the shifting lever, using a slotted quadrant with but two ratios in a slot and passing from one slot to another through an opening in the center. While this arrangement on the face of it has a clumsy look, an experienced operator can feel his way from one point to another much easier with this system than with the notched quadrant.

For ignition purposes the jump-spark system is head, neck and heels ahead of the hammer break. In spite of the fact that the coilmakers disapprove, the use of one coil with distributor for multiple-cylinder engine is growing in favor. It is liked for several reasons. It cuts down the amount of apparatus and simplifies the wiring, and, more important than all, it gives a more even operation of the engine.

The use of a direct-gear magnet to with distributor and one coil or transformer is a welcome addition. The magnet to is usually so wired that sufficient voltage for ignition is given when the engine is turned over slowly. This makes the use of a battery unnecessary and simplifies the ignition system greatly, as

the only wiring is from the distributor on the magnet to the spark plugs.

For the spark plug, the mica-cored plug has possibly a shade the best of it, although there were quite a few porcelain plugs exhibited and shown on the cars. The plug maker is discovering that shellac is detrimental to the success of a mica plug and many of them are abandoning its use altogether. Those who do use it to any extent are baking the plugs, so I understand. While great promises have been made during the past year, no new material for plug insulation has appeared, an earthenware core being shown only by Herz & Co., who have been using this material for several years.

The vaporizer is slowly but surely passing to a general adoption of the compensating principle. To explain, it should be said that when gasoline is drawn into the air passages by the air current during its passage by a nozzle, the action is peculiar. As the speed of the air current increases the proportion of gasoline that is picked up is greater in proportion to the volume of air than at slow speeds. In order to keep the mixture constant without manipulating the gasoline valve some means must be employed to introduce pure air between the gasoline nozzle and the engine cylinder. In vaporizers made several years ago this was done by moving a valve by hand. This proved unsatisfactory, as the regulation of the mixture by hand in this way was mostly guess work and required skill to obtain the best results. By putting this auxiliary air valve under the control of the air current itself an increase in the speed of engine and consequent increase in speed of the air current opens a compensating shutter and allows fresh air to enter between the nozzle and cylinder, diluting the otherwise too rich mixture. There is still another way of obtaining this compensating action, that is by placing the nozzle at the throttle opening so that as

the throttle is opened to admit more air to the engine, the construction around the gasoline nozzle is enlarged and the speed of the air current surrounding the nozzle is decreased. In this type of vaporizer, which I call the "automatic," the gasoline valve must be opened, as the throttle is opened in order to keep the mixture constant.

In general the pressed steel side frame as well as pressed steel hangers for the engine and the transmission are so generally used as to be considered standard practice. Quite a number of machines have either a pressed steel or an aluminum pan beneath the engine and the transmission. Longer and wider springs are used this year, and the general adoption of the side entrance tonneau has caused the wheel bases to be lengthened. Very few side entrance cars have wheel bases less than ninety inches, and the majority of the larger cars run to wheel

bases of over one hundred inches. In the foreign cars much longer wheel bases appear, the F. I. A. T. building cars of 114-inch and 128-inch wheel base.

The side entrance tonneau has certainly captured both the public and the builder. In this revolution the public seems to be to blame. Even so long as two years ago several manufacturers considered seriously the adoption of this style of body, but it seems that the buyer wanted the French type and got it. The change is advantageous in every way and many are glad to see the passing of the rear entrance. The front is generally a box radiator and a straight hood. The front seat is usually divided and well upholstered, black being the favorite color, as it does not soil easily. Those cars at the show which were upholstered in fancy colors can not be considered examples of the usual practice, as they were for exhibition purposes only.

NOTES OF THE NEW YORK SHOW

Of the cars shown at the New York show even a greater percentage than hitherto were powered with gasoline engines, showing that this type of engine is increasing, if possible, in the popularity for this class of service over other types of machines. A few electric vehicles and fewer still of steam machines were shown, but the gasoline car unquestionably holds the main field.

As was to be expected, the type of gasoline motor used is not so well defined as the fact that some style of this kind of motor must be used in the greater percentage of cars sold. Not including the commercial cars, there were 207 gasoline vehicles displayed. Of these a fraction over 87 per cent were water cooled. One machine was both water and air cooled. There were one four-cylinder, two two-cylinder and nine single-cylinder horizon-

tal engines. Of the double-opposed type there were 39. In the vertical types 127 were of the four-cylinder style, while there were from five to a dozen each of the one, two and three-cylinder. There were two of the three-cylinder oblique type. While over 88 per cent of the motors last year were equipped with the jump spark system, this year shows over 90 per cent. Batteries predominate over ignition dynamos to the extent of five of the former to one of the latter. Two compound engines and two two-cycle types compete with the 203 four-cycle makes.

Governors, automatic carbureters, etc., are gaining ground, while the spark gap (for which so much was promised) has about disappeared.

A gasoline power lawn mower, exhibited by the Coldwell Lawn Mower Co.,

attracted much attention. The engine propels the whole machine and drives the cutter as well.

The Dayton Electrical Mfg. Co. showed a new coil which carries four cylindrical vibrator or nonvibrator coils.

A novelty shown by the Constant Spark Plug Co. is a plug, either end of which may be used for ignition. The end not used acts as a double spark gap, and has a brass cap ring with a mica sheet over the opening, so as to make the opening visible.

The H. H. Franklin Mfg. Co. showed six models, one a light runabout with the 12 H. P. four-cylinder air-cooled engine. A 30 H. P. touring car has cylinders 5 by 5 instead of 5 by 4 as in last year's models. The regular cast iron cylinder is used.

Apperson Bros. Automobile Co. showed their 40 H. P. Mechanically operated valves are used on the 25 and 40 H. P., but the inlet valves of the 50 H. P. motor are triple-seated automatic.

The Peerless Motor Car Co.'s cars are equipped with magneto and jump spark ignition. The valves and removable cages are on top of the cylinders.

The Duryea Power Co.'s three-cylinder phaeton is rated at 12 H. P., with $4\frac{1}{2}$ by $4\frac{1}{2}$ -inch cylinders. An alternating magneto without coil or batteries furnishes the ignition. Either jump spark coil or a magnetic spark plug are supplied. The cylinder heads incline toward the rear of the car.

In the four-cylinder vertical car of the Premier Motor Mfg. Co. the motor is placed transversely on the front of the frame over the springs. Mechanically operated valves, jump spark ignition, and air cooling by radiating flanges cast on the cylinder are used.

Four double opposed cylinders, rated at 30 H. P., constitute the engine of the Springer Motor Vehicle Co.

The Mitchell Motor Car Co. showed

two models which are made with either water or air-cooled motors.

John L. Dolson & Sons cast each cylinder in their 20 H. P. double opposed motors with half of the crank case.

The Eisenhuth Horseless Vehicle Co. again showed their compound motors which have two vertical high-pressure cylinders with the low-pressure cylinder between them.

Two-cycle motors were, of course, the feature of the Elmore Mfg. Co.'s exhibit. During the last year there were several rumors that the two-cycle type would, in 1905, be adopted by quite a number of other manufacturers, but they have seemed to stick to the four-cycle. The Elmore motor is a horizontal, twin-cylinder engine of 16 H. P., $4\frac{1}{2}$ -inch bore and 4-inch stroke. Make and break ignition is used, and the carbureters have a self-regulating device to suit the speed of the motor.

The horizontal, double-opposed motor of the Northern Mfg. Co. is placed on the forward end of the frame, the crank case extending rearward and the shaft longitudinally. Two cylinders comprise the muffler. They are placed under the frame and as the exhaust enters one cylinder at the front it is carried back to the rear of the second cylinder and escapes at its forward end.

The 50 H. P. motor of the Austin Automobile Co. is comprised of four vertical cylinders of $5\frac{1}{2}$ -inch bore and 5-inch stroke.

The James Brown Machine Co. incorporate air cooling in their three-cylinder motors. They adopt the plan used in some stationary engines of aiding in cooling the exhaust valve by placing the inlet valve so that the cool gas entering the cylinder is driven toward the exhaust valve. An automatic carbureter is used.

The cooling pins used by the Knox Automobile Co. are claimed to increase the cooling surface 32 times. The flywheel

arms have this year been given a fan-shape to aid in removing the hot air from the cylinder.

E. R. Thomas Motor Co. added a 60 H. P. racer to their exhibit of 40 and 50 H. P. cars.

Radiating surface of 1,600 square inches per cylinder is claimed for the air-cooled system of the Corbin Motor Vehicle Corporation. The 24-28 H. P. four-cylinder engine has the cylinders cast separately with soft steel combs set in grooves in the cylinders.

Five cars were shown by the Packard Motor Car Co., pressed steel frames being used.

Timing of ignition is effected in the cars of the Locomobile Co. of America by using helical cams and shifting the cam shaft.

Four and six cylinders are used in the cars of the Sturtevant Mill Co. The cylinders are arranged in the double-opposed manner. The larger engine is rated at 40 H. P. A system of centrifugal clutches is arranged in the fly-wheel. Each clutch consists of a number of thin plates which are forced together by weights, balanced by springs. Overcoming the tension of the springs causes the clutch to engage. The gears and sets of clutches are arranged so that the engine starts with low gear engaged, and by increasing the speed the speed changes are made automatically. Spark lead is automatic and the carbureter is throttled by a foot button.

The carbureter of the Royal Motor Car Co. employs the exhaust gases in a jacket to keep the mixing chamber at the proper temperature.

The tendency to get away from unnecessary parts is shown by the motor used in the car of the Standard Motor Construction Co. This is a four-cylinder motor without a crank case, except that formed by a protector when the engine is in place.

Air cooling seems especially appropriate for automobile sleighs, and a 4 H. P. air-cooled motor is used on the product of the American Motor Sleigh Co. The motor is direct connected to a counter shaft on which are three wheels. Rollers on rods travel on the cam track inside these wheels and operate rods on which are spikes to "kick" the sleigh along.

The Frayer-Miller car, of the Oscar Lear Automobile Co., embodies the blower system of air cooling. The 24 H. P. four-cylinder engine has separately cast cylinders which are provided with aluminum jackets, fitting on lugs cast from the cylinder wall. A blower in front of the engine furnishes a current of air through a pipe on top of the cylinder and leading to the jackets. The valves are placed on opposite sides of the cylinders, the spark plug between them.

By placing the four vertical cylinders with the shaft crosswise to the frame, the Marion Motor Car Co. exposes them to a natural draft.

Among the exhibits of the English Napier cars is a six-cylinder 45 H. P. chassis. A hydraulic pressure controls the air inlet.

The combined air and water-cooling system is shown by the Reliance Motor Car Co. in their 16 H. P. double-opposed motors. Below the combustion space air cooling is provided, while water cooling is used on the warmer portions of the cylinder.

One of the new exhibitors this year is the Reo Motor Car Co., who show a double-opposed motor $4\frac{3}{4}$ -inch bore and 6-inch stroke. The valves, which are on the upper side of the cylinder, are mechanically operated. An automatic carbureter is attached to each cylinder.

The Cadillac Automobile Company has added a four-cylinder model to their line. The cylinders are cast separately and have mechanically operated valves. The cam shaft mechanism varies the lift of the

valve and its timing by means of an oil pressure device and governor.

The Olds Motor Works, in addition to their old lines, show a new type of commercial wagon, in which there is a two-cylinder vertical motor, placed under the seat.

A twenty-passenger car is shown by Mack Bros., in which there is a four-cylinder engine.

Combined water and air cooling is again exhibited in the cars of the Maxwell-Briscoe Manufacturing Co. The valves and combustion space are water-cooled, the balance air cooled.

The Model Gas Engine Works have so arranged their bodies that they may be tilted up for inspection of the machinery.

Combined water and air cooling are used by the Covert Motor Vehicle Company.

All cars of the Winton Motor Carriage Company have this year four-cylinder vertical motors. Water cooling, with a special anti-freezing mixture, is used. But one float feed, water-jacketed carbureter, is used.

Copper water jackets are used on the 20 to 40 H. P. Pope-Toledo motors.

F. B. Stearns shows only four-cylinder cars, cylinders cast in pairs, $4\frac{3}{8}$ inch bore, $5\frac{1}{4}$ inch stroke. They are completely water jacketed.

The smallest car on exhibition is that of the Detroit Automobile Manufacturing Company, in which there is a $2\frac{3}{4}$ H. P. motor, air cooled, single cylinder.

The Motsinger Device Manufacturing Company showed their auto-sparker, equipped as heretofore with a governing device.

Byrne, Kingston & Co. exhibited their all brass Kingston carbureters, which are applicable to stationary as well as marine and automobile motors.

The G. H. Curtiss Manufacturing Company showed, among their motor cycles, the original Curtiss motor, which was used by Captain Baldwin in his airship Arrow at St. Louis last year.

The American Coil Company showed a line of coils, dynamos, plugs, etc. The R. E. Hardy Company displayed their line of "Sta-Rite" plugs, coils, etc.

A GASOLINE PROPELLED FIRE ENGINE

A gasoline motor chemical fire engine has been constructed for Leicester, England, by the Wolseley Motor Car Company. Owing to the hard nature of the work which this appliance has to fulfill, the vehicle has been designed upon substantial lines. The chassis is built of channel steel of heavy section, reinforced with stiff gusset plates and traverse members, riveted together. The wheel base is 9 feet 6 inches, and the track 4 feet 9 inches.

The wheels are of a special type. The rear wheels are slightly larger than the front, being 40 inches and 30 inches in diameter respectively. The wheels are of the wooden artillery type, but are specially reinforced with heavy wire spokes. The ad-

vantage of this arrangement is that not only is there additional strength in the wheel, but it can withstand very severe side strains, such as collisions with projections in the roadway, or the edging of the sidewalks, and the danger of collapse through rounding corners at high speed is appreciably reduced. The driving wheels are shod with heavy solid tires, while the front wheels are fitted with thick pneumatic tires to support the heavy weight of the vehicle. The wheel hubs run on plain phosphor-bronze bearings and the axles are made in one piece of best steel.

The car is driven by a four-cylinder horizontal engine, developing 24 H. P., running at a normal speed of 750 r. p. m. A single

float-feed spray vaporizer is employed, while the ignition is of the ordinary high-tension type with accumulators and trembler coil. Cooling is effected on the usual system, the water from the engine passing into a battery of flanged radiating tubes and being cooled by a current of air induced by a high-speed fan driven by the engine. The water then passes into the tank, and thence to the engine.

Ample lubrication is effected from the dashboard to all parts. The change speed gear is of the general sliding type, a new pair of wheels being brought into action each time the speed is changed. Four speeds forward and one reverse are provided, the forward gear giving speeds of 7, 11, 15 and 20 miles per hour respectively. The transmission is through the ordinary cone friction clutch mounted on the crankshaft and connected by a chain to the gear-box. Chain drive from the countershaft of the trans-

mission to the sprockets on the road wheels is employed. Adequate double-acting brakes, both foot and hand, acting on the drums cast on the sprockets of the road wheels are provided. The gasoline tank has a capacity for 10 gallons. The chassis is constructed to carry safely a load up to 28 hundredweight.

In the front of the engine is fitted a large double-beat alarm gong to give warning of approach along the streets.

The body is of substantial build, with seat in front for two men, including the driver, with a box seat at the back to accommodate two more on either side. At the rear of the chassis is a step for the accommodation of a fireman, and sufficient space for two first-aid chemical cylinders. Brackets are fitted on either side to carry a short ladder, while the equipment of the engine is completed by a chemical cylinder and hose reel.—*Scientific American*.

WOOD ALCOHOL AS AN ANTI-FREEZING MIXTURE

The *Autocar* has been testing a solution of wood alcohol as an anti-freezing mixture.

At first a five per cent solution was used, but as the water in the carbureter jacket froze up, it was deemed advisable to increase at once to ten per cent. It must be clearly understood, however, that the mixture was never circulated round the carbureter, for the tap was turned off right up to the time the freezing took place; therefore, there could have been nothing but pure water in that part. With the ten per cent solution all was well through some hard frosts early in December, but a little more alcohol was added so that the strength was about fourteen per cent. With a view to testing the efficiency of the mixture, the car was left out of doors for two frosty nights in suc-

cession without any harm arising from this harsh treatment. The proof of a matter of this character is undoubtedly in the testing of it in an everyday manner.

The question of danger from ignition arose and the solution was poured over a bricked path and lighted matches were thrown down on to it; four were ineffectual, but the fifth ignited the spirit. The flames produced were just the same as burning whisky, excepting that they did not appear to produce so much heat. When diluted with water there did not appear to be the slightest possibility of setting fire to the solution as it is used in the radiator.

Loss by evaporation was not at all apparent nasally, but there was no mistaking it when the cap was off the tank or radiator filler.

SELF-PROPELLED RAILWAY CAR.

The inexpensive service at short intervals of time between local points, and the additional advantages for branch lines are two of the reasons that are calling into being the self-propelled railway car. Storage battery cars have been tried and abandoned in Europe. Steam cars have also been tried with more or less success. But the car that is most looked forward to is the car to be propelled by an internal combustion engine. Such a car is said to be in experimental use by the Jamestown, Chatauqua & Lake Erie Railway. Another is being tried by the Chicago, Burlington & Quincy Road at Aurora, Illinois.

It is said that the Lake Shore & Michigan Southern have placed an order for several 100 H.P. gasoline engines to be used on a number of passenger cars, the intention being to establish a service for local business between Toledo and Cleveland, and at other points where electric trolley lines offer competition to the steam railroads.

Another road in the same section of the country, the Ann Arbor, is expecting to meet a projected electric line with a motor car service of every two hours between Toledo and Ann Arbor, Mich.

The Clover Leaf Road is reported to have under consideration drawings for gasoline propelled motor cars. Passenger, special milk and express cars may be put into service.

The car illustrated herewith has been contracted for by the Southern Pacific Railroad Co. The engine is being built by the International Power Co., Providence, R. I. The General Electric Co. will furnish the electric parts, and the American Locomotive Co. will supply the trucks and frame work. Four two-cylinder engines, using crude oil

for fuel, will supply the power to operate the dynamos, which supply the current for running the car.

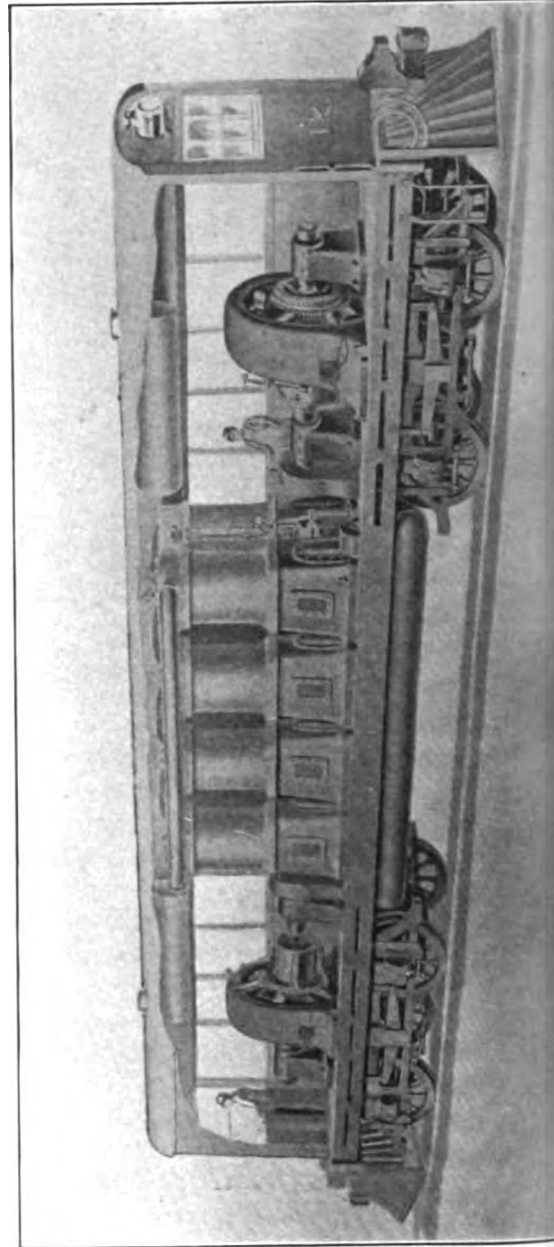

TRADE PUBLICATIONS.

Harry C. Gosper, of Elmira, N. Y., sends us a very neat little calendar, which is sent out in behalf of the Gosper gas engines, which are manufactured by F. J. Humphreys, of Skaneateles, N. Y.

The Wm. Powell Co., of Cincinnati, O., have issued their customary calendar, in behalf of their "White Star" valve. The pad is a weekly one and of sufficient size to be easily read at quite a distance.

"Lava" is the title of a booklet from the American Lava Co., Chattanooga, Tenn. There is much information relative to this commercial article, which is popularly supposed to be a natural volcanic substance.

The Fahnestock Transmitter Co., 132 Havemeyer St., Brooklyn, N. Y., are sending out a mailing card showing their spring binding post, which grips battery wires without the use of a binding post.

The Losch Engine Co., Ltd., of Reading, Pa., send a circular of the Losch coal oil engine, which is of the two-cycle type. The governor controls both the air and the fuel, maintaining a constant ratio in the mixture.

"Gas Work vs. Guesswork" is the title of an extremely attractive folder issued by the Marinette Gas Engine Company, Chicago Heights, Ill. The cover design shows a "gateway of profit," which may be opened by dollars, and leads to a Walwrath engine.

The Westinghouse Electric & Mfg. Co., of Pittsburg, are sending out a 1905 diary. In addition to the usual features of these pocket diaries, there is given much electrical and mechanical data, such as amount of power required for electrically-driven machine tools of various kinds, equivalents of electrical units, heat value of some American coal, performance of a 175 H.P. Westinghouse gas engine, com-

parative cost of power generated by a steam plant and by a coal gas works using part of its output for generating electricity by gas engines.

John Fox & Co., 63 West Eleventh St., Covington, Ky., list engines from 1 to 4 H.P., inclusive, in a circular received from them. These are four-cycle engines. This firm is also bringing out a two-cycle type. They also deal in second-hand engines.

The Peru (Ill.) *Daily Tribune* recently published an edition in behalf of the various industries of Peru. Among others was a description of the Peru foundry, machine shops and boiler works, owned by Mr. Charles Brunner. In 1872 Mr. Brunner began the manufacture of gas and gasoline engines, which are built in several styles.

"Standard" marine motors from 12 to 300 H.P. are shown in a well-illustrated and well-printed catalogue of the Standard Motor Construction Co., 180 Whiton St., Jersey City, N. J. This same company makes a special spark generator which is guaranteed to give a spark at as low of 30 r.p.m.

The Dean-Waterman Co., of Covington, Ky., are bringing out a new catalogue of their "Dean" gas engines. A special feature of the catalogue will be the listing of various "Dean" engine installations under the various business classifications, for easy reference for the prospective purchaser.

Circular of a valveless, automatic gas and gasoline engine is being sent out by the Robertson Mfg. Co., of Buffalo, N. Y. The piston covers and uncovers the inlet and exhaust ports, which are cast in the cylinder. The engine is double-acting and has electric ignition. The manufac-

turers state that as an experiment one of the engines was submerged in four feet of water, with only the supply and exhaust pipes extending out of water, and under these circumstances it ran for a number of hours until the fuel was shut off.

The January issue of *The Blacksmith and Wheelwright* celebrated the twenty-fifth anniversary of the founding of the paper. A souvenir number was issued and it contained many special features. The cover was a very attractive one, showing the outside and the inside of the customary blacksmith shop.

The Dayton Electrical Mfg. Co., 139 Reibold Bldg., Dayton, O., have issued a catalogue which illustrates and describes the Apple ignition apparatus. They are showing the Apple igniter which sells for \$15, the Apple dynamo with spring and plain base, their friction and belt governors and their storage batteries, spark plugs, spark coils with vibrators,

The Marinette Gas Engine Co., of Chicago Heights, Ill., have issued a new catalogue of their "Walrath" gas and gasoline engines, which are of the four-cycle, throttling governor type. A folder accompanying the engine bears the title of "The Full Dress Gas Engine," and its contents give special points of advantage. Both catalogue and circular are well printed and well illustrated.

The Commercial Electric Company, Indianapolis, Ind., have a very well printed bulletin, No. 35, of electric generators, etc. This company is making a special gas engine generator, which is equipped with a fly-wheel, the hub of which is cast with an extension or sleeve. On this sleeve is placed the pulley, so that the shock or pull of the belt is felt by the fly-wheel and taken care of instantly.

Some of the best advertising specialties that we have seen recently are received from the Advance Mfg. Co., of Hamilton, O. This company has used a hand in their advertising literature in the past, and one of the circulars just received shows the "Hamilton" portable engine on a hand. On the back of the circular are some original ideas as to the human temperament as indicated by little tricks of the hand, etc. Another card from this firm gives a calendar for January, 1905, beside which is a "Hamilton" engine shown on a peach, bearing the appropriate words, "It's a peach." Most practical of all, however, is a three-bladed, durable pocket knife, on the celluloid handles of which appear a "Hamilton" engine with the name and address of the firm. While more expensive to send out than circulars, the advertising value is certainly much greater in giving away such a lasting evidence of the good qualities of the "Hamilton" engine.

I T E M S .

The following were given by an English speaker as the average B. T. U. consumed per 1 H. P. per hour by steam, gas and oil engines, respectively: 13,011, 8,817 and 5,930.

Most engineers, says *The Engineer* (of London), will be surprised to learn that the gas engine dates back to 1820, when an internal combustion motor was shown in operation at Cambridge. According to a let-

ter by Mr. F. J. Jervis-Smith, of Trinity College, Oxford, it was the invention of the Rev. W. Ceal, Fellow of Magdalen College, Cambridge. A full account of his engine is given in volume I, page 217, of the "Proceedings" of the Philosophical Society of Cambridge—a paper read November 27, 1820. A new form of parallel motion is described, and what the author calls "ardent spirit" and turpentine and vapor of oil are suggested as possible substitutes for gas

R E A C H L E S S D O U B L E S P R I N G G E A R
--

The accompanying illustration shows a running gear built on specifications of a thoroughly first-class mechanic, who constructed a car according to his own ideas. One of the chief points is the double spring construction, the one spring being used to take up the vibration from the wheels in contact with uneven roads, and the other spring being attached to the body. This means that in actual service, when the vehicle is standing still, but the engine is running at full speed, the disagreeable motion to which passengers in most automobiles are subjected, is entirely eliminated.

The chassis shows all the mechanism in the center and rear, leaving the front

carrying only the weight of the radiator. The entire chassis is furnished in parts by the J. H. Neustadt Co., of St. Louis, Mo., to be constructed by the purchaser. All parts are finished, except painting. No machine work is necessary. Suitable bodies may be supplied according to the purchaser's requirements.

This is but one of the many specialties furnished by the J. H. Neustadt Co., consisting of everything in the way of parts for automobiles.

The company recently issued a very complete 95-page catalogue of their products. There are shown air-cooled and water-cooled engines and various styles of gears and bodies.

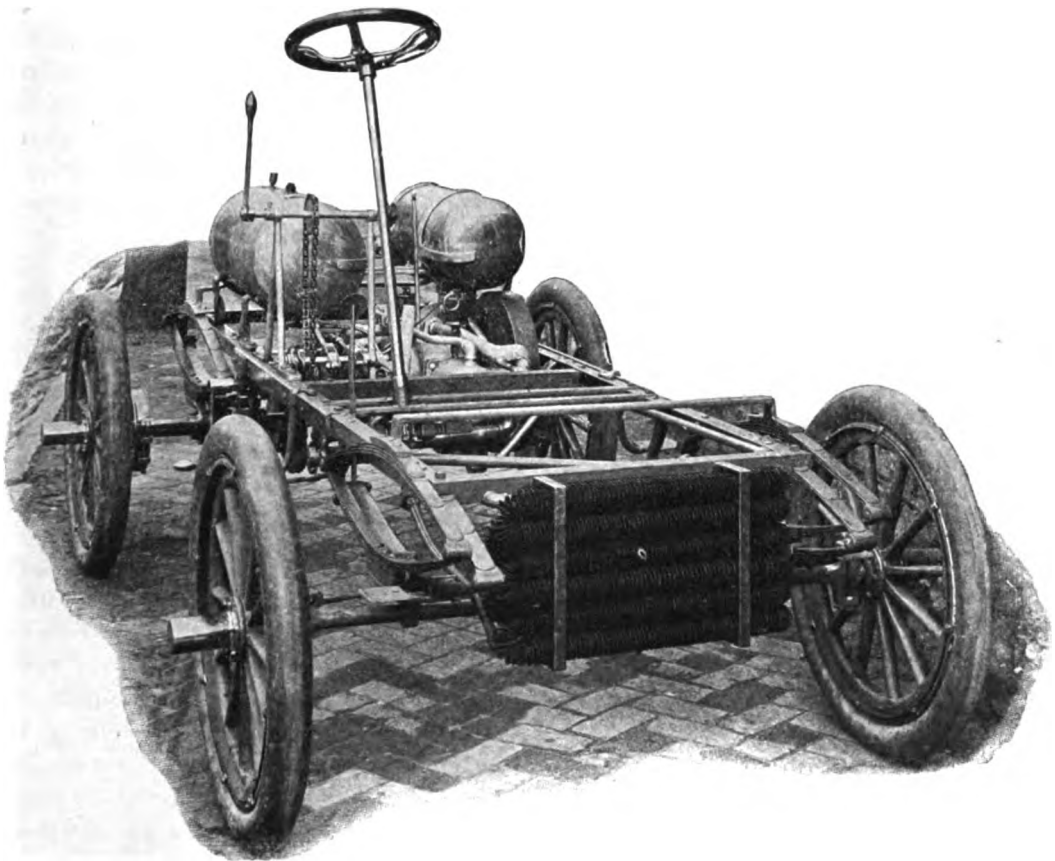

INDUSTRIAL ITEMS.

The Meriam-Abbott Co., of Cleveland, O., has been succeeded by the Bruce-Meriam-Abbott Co.

The Newport (Ky.) Milling Co. is installing a 15 H.P. Fairbanks-Morse engine in their elevator.

A mortgage of \$60,000 has been filed by the King Gas and Gasoline Engine Co., of Battle Creek, Mich., successors to the Coburn Machine Co., to pay up indebtedness and increase their capacity.

The Frontier Gasoline Motor Co., of Buffalo, N. Y., has been organized to manufacture, lease and sell gasoline motors. Capital \$10,000. Directors are Louis Ducro, W. H. Ahlers, George F. Graf and Oscar R. Cheney.

Prof. C. M. Woodward states that a cost of 2.15 mills per H.P. hour for fuel was the record of the three Diesel engines used at the St. Louis Exposition. The work done was measured at the switch-board, and the fuel was Indiana oil, costing three cents a gallon in car-tank lots.

A correspondent in Mexico states that for the past two years he has been operating three gas engines, aggregating more than 300 H. P. on gas made from charcoal. He is now experimenting with a suction gas producer to use wood and soft coal, as well as anthracite and charcoal.

The Fischer Special Mfg. Co., manufacturers of spark plugs, spark coils and electrical and mechanical apparatus, have moved to their new factory, 2076-2078 Reading road, Cincinnati, O. Owing to increased business and to better accommodate their patrons, they have erected a large and commodious plant, equipped with up-to-date machinery, thereby enabling them to give first-class work and prompt service.

The Shell Lake (Wis.) Boat Co. has been organized with a capital stock of \$25,000. G. L. Schwab, formerly with the Pearson Boat Construction Co., Duluth, is Superintendent and Manager. Gasoline launches will be built.

In the Presidential address of an eminent English electrical engineer the speaker said that he had had the installing of two four-cylinder 300B.H.P. gas engines, which, running under varying loads and with varying thermal efficiencies of gas, were equal to the best steam engines for steadiness of running.

The factory of the Morton Traction Co., York, Pa., has been closed at York, and that company has joined the Ohio Mfg. Co., at Upper Sandusky, O., where they will have increased facilities, as well as an improved location, being nearer the traction engine territory. The company makes traction rigs on which gasoline engines may be mounted, constituting gasoline traction outfits.

Several months ago we published a description of the "Monitor," a gasoline-propelled canal boat used between Cincinnati and Lockland. A second boat of the same type, called the "Ajax," was put into service the last of November. Five or six more boats of the same class are in process of construction. Motors built by the Clifton Motor Works, Cincinnati, are used for power.

The Western Launch and Gas Engine Works, Mishawaka, Ind., which manufactures "Recreation" launches and "Western" gas engines, will remove its office and works to Michigan City, Ind. The company has been reorganized under the name of the Western Launch and Engine Works, Inc. The company will build boats of all kinds, from a small rowboat to a 75-foot cabin yacht.

THE GAS ENGINE.

STATIONARY—AUTOMOBILE—MARINE.

PUBLISHED MONTHLY BY

The Gas Engine Publishing Co.

Blymyer Building, Cincinnati, Ohio.

ADVERTISING RATES ON APPLICATION. Address All Communications to the Company.

Entered at the Postoffice at Cincinnati, Ohio, as Second Class Matter Feb. 20, 1899.

VOL. VII.

MARCH. 1905.

No. 3.

Domestic Subscriptions, \$1.00 per Annum.

Single Copies, 10 cents.

Foreign, \$1.50 per Annum.

"This gas engine business is a campaign of education," said a gas engine manufacturer recently in talking about the business in general. The truth of his remark is admitted by all who are in touch with the trade. A user of a gasoline engine in a letter to us expresses the opinion that the gas engine business is in the hands of unprincipled men who are putting out engines which will not run and which should properly be consigned to the scrap heap. His opinion is based largely on the experience he has had with an engine which did not come up to the specifications of the one he thought he ordered. Without knowing anything further about his case than his own statement, which we have no reason to doubt, we must say that the gas engine business is largely one of education. The manufacturer or dealer who can successfully educate his customers to the point of giving the engine proper care is the manufacturer who is most successful. To secure this proper care, intelligent handling is necessary. Intelligent care is the result of a knowledge of the operations of the engine, of how it should operate, and an ability to determine where the trouble is in case it does not operate as it should.

The wide distribution of good gas engine literature among users and prospective users of engines is one way in which to create this intelligent care. For this reason money spent in catalogues and instruction books, in explaining the operation of the engine, is money well spent.

For the same reason the spread of such literature as is published in this magazine is a help to every manufacturer of engines, for it adds to the "campaign of education." It has been the policy of this magazine since the time of its beginning, over six years ago, to add to the educational campaign and to impress on the minds of users and prospective users of gas and gasoline engines the necessity of properly understanding their engines. To assist in this, articles of an educational nature are constantly being published by us.

In another column will be found reference to some tests made in France for the production of power gas from hay, straw and other farm vegetable products. This indicates one of the possibilities of producer gas and the gas engine. So wonderful have been some of the experiments of the last few years that the possibilities opened up are far beyond what would have been dreamed of by even the most visionary of advocates forty years ago. And yet we must bear in mind that possibilities are not actual commercial successes today. Whatever they may be in the future—even the immediate future—we must remember that for present day commercial installations, commercially successful plants must be used. As one manufacturer recently put it: "Our fear is that there will be a wave of disappointment experienced if there is any extensive

adoption of some of the ill-digested systems now offered to the public." This manufacturer has been experimenting with a power gas producer for over three years, but will not put it on the market until he is satisfied that he has overcome all of the difficulties which he has experienced in the past. From what we hear, not all other manufacturers have been so observing of the necessity of supplying a commercially successful plant. We would not for one moment be understood as saying that all such plants offered are not commercial successes when installed under the conditions prescribed by their manufacturers today. The fact is that there are many of them in successful operation, but we have learned of some fail-

ures which, as above indicated, show that the manufacturer had not completed all his experiments before placing his producer on the market.

We have been asked why we have not published a list of the gas engine awards at the St. Louis Exposition. Our reason for not doing so was that, although the officers promised on some half dozen occasions to give us an official list of the final awards, they have never done so. While from outside sources we have learned of some of the awards, yet we understand that as originally made the awards were contested and later changed, and we have not felt justified in publishing a list which had not been authorized

GETTING FUEL TO THE GAS ENGINE.

By ALBERT STRITMATTER.

Fuel is necessary for a gas or gasoline engine, and yet it is strange how many engine users will forget that unless fuel is supplied to the engine it will stop. How many times do gas engine experts go to locate trouble with an engine, only to find that the gasoline tank is empty?

A gas engine manufacturer, in talking of this matter recently, told the writer that he had sold an engine some 200 miles from his factory and the Sunday following its shipment he was called up by telephone by the purchaser, who stated that on the day before (Saturday) he had gotten the engine installed nicely, and it went off almost at the first attempt, but Sunday morning when he went to pump some water for his stock, he couldn't start the engine at all.

"Are you sure that there is gasoline in the tank?" asked the manufacturer.

"Well, I'm pretty sure," was the reply. "I filled it up yesterday morning."

"That's just about long enough ago to make it certain that you need some more

in it by this time," answered the manufacturer.

The customer promised to see if this was the trouble, and, after some further admonitions, left the telephone. Later he wrote that after filling the tank the engine went off all right.

Another manufacturer, in the course of a talk on the subject of educating the user of an engine, mentioned a case where an engine had been installed for operation on gas. Some time afterwards the customer wrote that he had been unable to start the engine and that he had employed a local machinist, who claimed to have had some gas engine experience, but this man had given up the job after three days' time on it.

After correspondence, the manufacturer sent one of his men, on the agreement that the expense would be borne by the customer if nothing was found wrong with the engine. Otherwise, the manufacturer was to stand the expense.

When the expert arrived he refused to

touch the engine until the customer showed him what method was used in trying to start. Not getting the engine started, the expert sent for the local machinist and had him try to start the engine, but he also failed.

Then the expert said to the machinist: "You turn on that gas cock by the meter, and then try to start it."

As is customary, a cock was placed in the gas pipe at the engine and another in the pipe near the meter. The latter had in some way been shut off and neither the user of the engine nor the machinist had discovered that the engine was not getting gas.

This same manufacturer mentioned another case, similar to that first mentioned. He was called out into the country to see what was the matter with an engine, and on reaching the place asked the owner of the engine to put a stick into his gasoline tank and see how much gasoline he had in it. The result was that the tank was discovered to be almost empty.

In another case a gasometer had been used to regulate the gas pressure. This is a galvanized iron receptacle partly filled with water and having through its bottom the gas supply pipe, which opens right into the gasometer. A floating top extends over the opening of the pipe and into the water, holding the gas in the gasometer. When the pressure inside the float raises the top to a certain point a valve in the supply pipe is shut off. The engine sucks gas from the gasometer and as the gas is taken from it, the floating top lowers and the supply pipe valve opens. Now the weight of the floating top creates a certain pressure of gas in the pipe line from the gasometer to the engine, and this assists the sucking action of the piston in giving a full charge to the engine. The user of the engine learned by experience, therefore, that in starting the engine there would be a proper size

charge of gas admitted if the dial cock in the supply pipe were set at a certain point.

A sort of gas bag was later put in, instead of the gasometer. This was really nothing more than a large opening into which the gas could be collected until the engine should need it. After it was put up, the engineer could not start the engine. If the gas was taken from the gasometer the engine started off all right, but when switched back to the gas bag would not start.

This set the engineer to thinking, and all of a sudden it dawned on him that the weight of the gasometer top created a certain pressure in the gas pipe to the engine, but the gas bag did not have this same weight and therefore the gas in the bag and in the pipe leading to the engine was not under such pressure. Therefore, when the gas valve opened the gas did not flow as freely into the cylinder. Consequently, it was necessary to open the dial gas valve to a further point to admit sufficient gas, at this lower pressure, to make an explosive mixture. As soon as this was done, the engine started off promptly.

But gas and gasoline do not constitute the whole fuel used by the engine. Air is just as necessary for the engine, and is an important constituent of the fuel mixture. The writer has known of some cases where the air pipe was too small, or was clogged up, or was so long and tortuous with turns and bends that the air got to the engine with difficulty. In other cases air was taken from the room in which the engine was installed, and there was not sufficient ventilation to give the engine plenty of air.

A case of this kind which comes to mind was a retail store where a 2 H. P. engine was used to operate a blower for a system of carrying change cases in a compressed air tube. The engine was put

down in the cellar, where parts of the stock were kept, and where everything was as nearly air-tight as possible, to prevent the accumulation of dust on the stocks. Not satisfied with this, the people built an airtight partition around the engine and blower, leaving barely enough room inside the partition for a person to get in and shut the door.

The result was that the engine, which was to take its air from the engine room, could hardly get sufficient air to keep itself moving. In fact, this was about all it did do, and dissatisfaction was the result.

And the dealer who sold the engine could hardly convince the user of it that the engine required air

The user of an engine can not be too strongly impressed with the fact that any derangement of the fuel feeding or mixing devices means loss of power, and increased fuel consumption, because the full possible power is not acquired from each charge. It is cheaper to burn gas or gasoline and air in the proper mixture than to burn gas and gasoline with too little air. Gas usually comes in through a meter, while air doesn't.

POWER GAS FROM VEGETABLE PRODUCTS.

Last summer and fall a series of experiments was made by Menier Bros., Noisiel, France, to investigate the possibility of generating power gas from vegetable products. An account of the experiments was laid before the Academie des Sciences and the following information was taken from the Comptes Rendus in which the account appeared.

A generator of the Riche type and a 70 H. P. Duplex gas engine were used in all the tests, the engine being prepared for gas of low calorific value.

Where a small quantity of power is required on farms, it is often customary to employ coal and either portable or stationary engines to produce it. The coal has sometimes to be conveyed at considerable cost to the spot; and as the engines are not always well constructed, it requires considerable fuel to produce 100 H. P. Even when petroleum or heavy oil is employed, the cost is still high, though less than that of coal. The experiments at Noisiel were undertaken with the view of effecting economy in this respect, and at the same time of disposing of certain vegetable products. A poor

quality of hay, wheat and oat straw, poplar and plane tree leaves, rushes, reeds, and moss were found to give such satisfactory results that a suggestion was made for the formation of a syndicate to put up works and supply a group of farmers who employ 40 or 50 H. P. and upwards. For running these works, no mineral fuel would be used except a little coke or charcoal.

The hay used was obtained from swampy meadows in the department of the Marne. Its percentage composition was: Ash, 5; water, 14; nitrogen, 1.5; potash, 1.2; soda, 0.07; lime, 0.6; magnesia, 0.27; silicic acid, 1.5; sulphuric acid, 0.2; and phosphoric acid, 0.3. With this material, an effective horsepower was obtained by using 2.2 pounds. No special care was taken in charging the generator; the hay being thrown in and slightly pressed down with a pole. At the bottom of the generator there was formed a potassium clinker, which it was found could be utilized as manure. The straw of wheat and oats gave, on the whole, better results. The wheat straw was of the following percentage composition: Ash,

4.2; water, 13; nitrogen, 0.52; potash, 0.87; soda, 0.08; lime, 0.26; magnesia, 0.10; silicic acid, 3.60; sulphuric acid, 0.11; and phosphoric acid, 0.21. An effective horsepower was obtained with 2.3 pounds.

The next experiments were made upon produce of another kind—viz., rushes, reeds, and moss. It was found that these materials could only be treated profitably when they contained little water. Fallen leaves were tried; the leaves being gathered in the autumn. The beech leaves had the following percentage composition: Ash, 4.7; water, 14; nitrogen, 1.3; potash, 0.23; soda, 0.05; lime, 2.12; magnesia, 0.30; silicic acid, 1.5; sulphuric

acid, 0.075; and phosphoric acid, 0.22. With 1.3 pounds of these 1 H. P. was obtained. Oak leaves, with much the same composition, gave similar results. Chestnut leaves required 1.32 pounds.

The final experiments were made with sawdust, shavings, and scraps of wood. It was found that poplar tree sawdust had the following percentage composition: Ash, 2.8; water, 15; potash, 0.74; soda, 0.18; lime, 1.1; magnesia, 0.2; silicic acid, 0.008; sulphuric acid, 0.14; and phosphoric acid, 0.3. To produce 1 H. P. with sawdust, it was necessary to use almost 4 pounds, but with shavings, this quantity of power could be obtained with not quite 3 pounds.

THE GAS ENGINE IN ICE CREAM FACTORIES

The ice cream factory is one of the types of factories which require some kind of power at an economical cost and yet which will not require the attention of an expert mechanic to keep it in operation or repair. The gas or gasoline engine has been adopted by many of these factories as the ideal kind of power for such a plant. Not all of these installations use small-size engines, and at Warren, Pa., there is an ice cream company using a 50 H. P. gas engine with a reserve plant consisting of a 30 H. P. gas engine and a 20 H. P. steam engine.

In the *Ice Cream Trade Journal* Mr. Albert McDougal calls attention to the advantage in the use of a gas engine in ice cream factories, as follows:

A paramount necessity in the ice cream factory of today is a reliable source of power, but it is wholly unnecessary that economy be sacrificed to secure it.

There are some manufacturers who still pin their faith to the steam engine regardless of cost of installation and operation, the complicated nature of the

plant required and the necessity of employing a licensed engineer, who in all likelihood will ever be found "too busy" to do more than look after his engine. This is difficult to understand, for surely economy is as necessary in the ice cream business as elsewhere.

For small plants—and the average plant is small—where from 5 to 10 H.P. is more than ample, the initial cost and operating expense of a steam power plant are prohibitive. Both reason and the pocket demand that another source of power be found—and attention is turned to the gas engine or the electric motor. The convenience of the electric motor appeals to many so strongly that cost of operation is hardly considered—until after the bills begin to come in. The wiser manufacturer investigates thoroughly—and installs a gas engine, to the lasting benefit of his pocket.

Larger users of power are less easily weaned of their preference for the "good, old, reliable" steam engine. I shall not attempt to question the reliability of the

steam engine, but shall content myself with asserting the equal reliability and greater economy of the gas engine.

It has been shown repeatedly by competent authority that even where horsepower into the hundreds is required, certain types of gas engine are more economical than steam engines, just as reliable and much easier to manage; but, as my particular purpose at this time is to present facts of interest to average power users in the ice cream field, I shall deal with average power units.

Leaving aside first cost, relatively a matter of lesser importance, let us look into cost of power or operating expense. The comparative tables presented in connection with this article are compiled 12 H. P. engines, averaging 5 H. P. for 10 hours:

STEAM ENGINE. COAL	GAS ENGINE. GAS	ELEC. MOTOR CURRENT
Fuel.....\$.70\$.70\$1.75
Oil & Waste.070605
Water.... .030000
Att'dance 1.0010	Att'dance .10
<u>\$1.80</u>	<u>\$.86</u>	<u>\$1.90</u>

20 H. P. Engine full power 10 hours.

STEAM ENGINE. COAL	GAS ENGINE. GAS	ELEC. MOTOR CURRENT
Fuel.....\$3.20\$2.00\$6.40
Water.... .100000
Oil & Waste.201515
Att'dance 2.001010
<u>\$5.50</u>	<u>\$2.25</u>	<u>\$6.65</u>

from statistics of a series of tests applied under average working conditions. They are based on New York gas and electric current and on coal at \$2.60 per ton. No water charge is set against the gas engine, as only a small tankful is required for use in cooling the cylinder. Wear and tear is not included, as in any case that depends largely upon the make of machine and the attendant.

As further showing the economy of the gas engine, I may cite a statement that appeared in the *Electrical Review* to the effect that a given volume of gas utilized in a gas engine coupled to a dynamo produced in incandescent lamps three times as much light as would have been produced had the gas been burned direct at gas jets, and in arc lamps the production of light was as eleven to one. On this showing the logical conclusion is that if the electric motor is to equal the gas engine in point of economy of operation, power to generate the current for the motor must be furnished at one-third the cost of gas engine power—an undertaking that would seem to be somewhat difficult. Test this conclusion by another examination of the table of cost for steady full power. It will be seen that one supports the other perfectly if allowance be made for a very trifling difference in conditions.

NAPHTHA AND GASOLINE ENGINES.

We are occasionally asked the question: "What is the difference between a naphtha boat and a gasoline boat?" A writer in *Railway and Marine News* recently answered the question by saying that the simplest answer would be that naphtha uses the gasoline in the same manner that a steam engine would use water and its force generated by the expansion of naphtha or gasoline, by heat into vapor under pressure which is

forced through the cylinders of the engine, which in turn exhaust, or discharge their contents in the base of the engine. From there the gases are returned through a condensing coil under the boat and are cooled by the water through which they pass, and the gases in passing through this condensing coil are cooled and condensed back again into gasoline, which is returned by gravitation into the tank from which it came.

In the naphtha engine the gasoline is heated in a coil by a blast of gasoline gas in flame and this engine has a large heating chamber usually encased in a large brass tube or stack, and to the popular mind it can best be distinguished from a gasoline boat by the roar from the smoke stack which passes out above the engine.

A gasoline engine is operated by the explosive force of gasoline gas. In this engine the gasoline is not burnt and there is no fire about the gasoline engine. The gases are made in a device attached to the engine called the carbureter, or mixing valve,

wherein a blast of air is thrown against a spray of gasoline and the two coming together, the carbon in the gasoline is readily distributed through the air in the mixing valve and from thence it is taken into the cylinder in the engine. As the piston in the engine passes upward toward the top of the cylinder it compresses the gas and at the proper time an electric spark is discharged into the gases, thereby causing an explosion which forces the piston down into the cylinder, and this operation continues, making a succession of explosions which propel the engine.

**NOTES ON THE THERMAL EFFICIENCY OF
MODERN MOTIVE-POWER ENGINES.**

Such is the title of an article by Mr. B. H. Thwaite, which appears in the current number of the *Vulcan*—a monthly newspaper published in Manchester. In it the author expresses his dissent from the views which have been recently expressed and discussed as to the practicability of constructing a really efficient and economical gas turbine, and proposes, as an alternative, a combination of the steam turbine and the reciprocating gas engine. He appears to have been led to this by the difficulty as to compression when applied to the gas turbine. This is no doubt a real one, although possibly over-rated by the adherents to the reciprocating type of engine. As Mr. Thwaite points out in the article, compression in the ordinary Otto cycle is effected within the power-developing cylinder, and, consequently, with a minimum of loss; whereas with the gas turbine it must be effected as a separate operation, and would be inevitably attended with considerable loss, resulting from the flow of the compressed fluid through contracted areas, such as the ports and other connections of the compression cylinder. He foresees, moreover, that the ideal power gas of the fu-

ture will be one in which carbon monoxide is the supreme agent of heat production, and in the use of which a high degree of compression is necessary to secure a sufficiently sensitive ignition. If, he says, a turbine gas engine is to be economic, its fuel agent must be a gas that will be ignitably sensitive with comparatively low degrees of pre-compression, such as is oil vapor, or a gas rich in hydrocarbons. This condition, however, brings with it the difficulty of a higher range of temperature in the working cylinder, and the danger of overheating of the actuating organs of the engine. These considerations lead him to conclude that the most practical solution of the problem how to obtain the highest degree of efficiency from the fuel employed, is to work the two power-producing agents—the gas engine and the steam turbine—in harness together.

The great progress which has been made during recent years in the construction of internal combustion reciprocating engines of high power encourages Mr. Thwaite to believe in the practicability of such a combination, in which would be utilized for steam production not only the sensible heat, which at the present time

is lost in the necessary cooling of the gas to the temperature of the atmosphere, but also the heat absorbed by the water employed to keep cool the working cylinders and some of the actuating organs of the gas engine, and likewise the exhaust gases of the latter. The steam thus generated would be available for driving a steam turbine; so that the two types of power generating machines would be acting in interdependent connection for a common service. Thus the absolutely perfect combustion of the gaseous fuel in the working cylinder of the gas engine would provide a great part of the thermal potential required for driving the steam turbine. The gasification process and the gas engine exhaust stages would be drawn upon to secure part of the balance of heat; the remaining thermal requirement being satisfied by direct combustion of the gaseous fuel in the steam boiler furnace. The steam turbine and its steam generating accessories would serve for starting the gas engine, and provide also the reversal motion requirements. The operation of such a combination is thus described: "The rapid starting of the gasification process with fan propeller, driven with steam initially generated with solid fuel to be subsequently displaced with gas, starting of the high-power vertical gas engines with the steam turbine; the reversal of the gas engines by the steam turbine, which will, of course, be compounded and equipped with condensers; the proportion of the gasification product required to be used in the steam generator will be small because of the thermal assistance given by the gas engine, hot jacket water, etc."

It is claimed that the application of this combination to ocean steamships might result in a total thermal saving of 55 per cent. on the best existing marine engine practice, besides a lessened consumption of water; while the tell-tale trail, to say nothing of the discomfort to passengers of

smoke issuing from the funnels of steamships, would practically disappear. For battle ships, it possesses additional features of strategic value. During an engagement, for example, the steam generating plant could be shut down altogether, and there would be no danger of self-destruction should the steam boilers be pierced with shot or shell; while the piercing of the funnels (of small proportion compared to those of existing practice) would not interfere with the efficiency of the gas engines. The fuel would be fed into the high-pressure gas generators automatically; so that the stokers' work in the boiler stoke hole of a battleship would be deprived of its terrors, and, owing to the reduction in the weight of fuel required for a given power, the storage space would represent more extended running power. A like proposition for inland service would assist in the prevention of smoke, and enable recovery to be made from bituminous fuel of the condensable hydrocarbons and ammonia; the program of operations involving only temporary use of solid fuel.

It will be seen that the scheme is a complicated one, and can evidently be applied only on a large scale. Indeed, the article commences with a statement which prepares the reader for this, by saying that "the economic supremacy of the principle of centralization in modern work of power-energy-development, and the distribution and transmission of such power electrically, is now proved beyond cavil."

In a paper read at a recent meeting of the American Street Railway Association, Mr. E. D. Meier stated that a 500 H. P. Diesel engine was being installed to operate a portion of the Sheboygan & Elkhart Lake Railway; that the German Diesel Company have built four engines of 400 H. P. each, four cylinders each (100 H. P. to the cylinder), which is being erected for the street railway and lighting plant at Kiew, Russia.

GAS ENGINES FOR FACTORY POWER

By G. M. HILL

Until very recently the installation of gas engines for factory purposes was of a very limited scope, owing to several reasons.

First, the gas engine was unknown to the average engineer, and was therefore mistrusted in favor of the old reliable steam engine.

Second, gas engines were only of fairly small capacities utilizing a very small quantity of power and fuel. It was less easy to get at that time to find a gas engine of any size that would prove economical and reliable. The reason for this was that the gas engine had not yet been developed to the point where it could be trusted to run for long periods of time.

The third reason why gas engines might not be used in factories was the fact that the machinery of the factory was not adapted to the use of gas engines. The machinery of the factory was designed for the use of steam engines, and the gas engine was not adapted to the use of steam engines.

The fourth reason why gas engines might not be used in factories was the fact that the gas engine was not adapted to the use of steam engines. The machinery of the factory was designed for the use of steam engines, and the gas engine was not adapted to the use of steam engines.

The fifth reason why gas engines might not be used in factories was the fact that the gas engine was not adapted to the use of steam engines. The machinery of the factory was designed for the use of steam engines, and the gas engine was not adapted to the use of steam engines.

The sixth reason why gas engines might not be used in factories was the fact that the gas engine was not adapted to the use of steam engines. The machinery of the factory was designed for the use of steam engines, and the gas engine was not adapted to the use of steam engines.

The seventh reason why gas engines might not be used in factories was the fact that the gas engine was not adapted to the use of steam engines. The machinery of the factory was designed for the use of steam engines, and the gas engine was not adapted to the use of steam engines.

The eighth reason why gas engines might not be used in factories was the fact that the gas engine was not adapted to the use of steam engines. The machinery of the factory was designed for the use of steam engines, and the gas engine was not adapted to the use of steam engines.

...the gas, while of only one cubic foot, forms an atmosphere of ... purposes for manufacturing ... hydrogen, it admits ... for very high ... without ...

this industry has already obtained a firm foothold among our manufacturers, and it would seem that the time is not far distant when the comparatively wasteful steam engine and steam boiler will be almost entirely replaced by gas and producer gas-engine plants.

In addition to supplying a means for the practical operation of the larger sized gas engines, the gas producer has added an impulse to the large gas engine trade which is very marked, for without a fuel gas of this description the sale of large engines was entirely restricted to the natural gas fields, while now it is practical to install a high-power gas engine plant wherever coal and water are available, with the result that although until quite recently quotations on gas engines of 1,000 H. P. or over could only be obtained from European firms, at the present time of writing no less than six American firms have submitted estimates for such high-power engines.

Visitors to the St. Louis Exposition had the opportunity to observe this type of machinery in actual operation; for a concern that is a pioneer in this line of work, had in actual service two power plants, one for the operation of the gas engine exhibits of one of our well-known engine manufacturers, while the other plant supplied gas for the testing plant of the United States Government in "The Gulch." Both these plants operated continuously and satisfactorily during the Fair, and their small coal consumption served as an object lesson to those who compared the workings of these plants with similar steam equipments.

Generally speaking, gas producers can be depended on to furnish one B. H. P. hour from $1\frac{1}{4}$ pounds anthracite pea coal, this type of fuel being the favorite for gas producer work, owing to the fact that the resultant gas contains no by-products to be gotten rid of by special machinery.

It can easily be estimated, with the data

now obtainable on the market, what the cost of an entire equipment of gas producers and gas engines, to replace a steam plant, would be; and while the first cost of the gas plant would appear considerably higher than the cost of a steam plant of the same capacity, the resultant economy would be so very great that it would pay a very high rate of interest on the money invested, and probably pay off the entire cost of the plant in about four years in addition.

In estimating on a gas producer power plant, the owner should first ascertain the exact maximum amount of power which he will be called upon to deliver, for gas engines, unlike steam engines, have no overload capacity whatever. Again, he should satisfy himself as to the cheapest and most readily obtainable fuel in his locality, as the builder of a gas producer can supply him with several types of gas producers designed for various grades of coal, both anthracite and bituminous, obtainable on the market; and furthermore, the cost of the plant will vary materially with the fuel to be employed. For example, a hard-coal plant will be much less expensive than one of the same capacity for soft coal, as in the latter case there are hydrocarbons in the gas which have to be removed by mechanical washers, or they would condense in the form of tar and gum up the engine.

Among the plants of this nature which have been in service sufficiently long to satisfy the most exacting demands may be mentioned that the Camden Iron Works, Camden, N. J., and that of the Erie Railroad Company, Jersey City, N. J. This latter plant has been in continuous service twenty-four hours a day for upward of five years since its installation, and indicates the thorough reliability of this type of plant when properly installed and efficiently handled.—*Scientific American*.

THE GAS TURBINE.

Among the rivals to the steam engine and the steam turbine, the gas turbine offers most enticing attractions, and the eagerness with which any authentic information concerning actual experiments in this line is sought is evidence of the extent to which the subject is being studied. Theoretically the gas turbine should be an operative machine from which an efficiency nearly, if not quite, equal to that of the four-cycle reciprocating internal combustion motor may be obtained. Practically there are many difficulties in the way, difficulties which it may require the utmost ingenuity of designer and constructor to overcome.

Thus the conditions of maximum efficiency in such a machine involve rotative speeds at which the centrifugal stresses become greater than the resistance of any available material of construction, while at the same time the working temperatures are indicated to

be those at which the resistance of almost any material would be gone anyhow. The efficiency of the gas turbine itself becomes also involved with that of the efficiency of some appropriate form of air compressor, and the rotary air compressor available for such purpose involves nearly, if not quite, as many constructive difficulties as those of the gas turbine itself. Nevertheless, we believe that the gas turbine will ultimately be made, and that it, or something like it, will be found superior to any steam engine which can be constructed. Meantime, the builders of reciprocating engines and of steam turbines will continue to produce their respective machines without fear of losing their business overnight, and the advent of the gas turbine will be heralded sufficiently far in advance to permit them to give themselves ample protection.—*The Engineering Magazine.*

THE USEFUL GAS ENGINE.

The gasoline engine has many advantages over any other power for farm use, unless it be electricity, and only in exceptional cases can electricity be obtained for power. Gasoline engines, when ignited by a battery, can be operated anywhere without danger from fire, and this is the great advantage over steam. It can also be started in a minute without waiting to get up steam, and when the work is done the expense stops at once. It requires no engineer, is automatic in action and self-regulating. At the Iowa State Fair last fall a traction gasoline engine was exhibited, and the operator would start it and get off and let it run around the circle with no attendant. The battery

is better for ignition than the flame, and is cheaper and safer.

For separating milk, churning, pumping, running saws, shredders, fanning mills, washing machines and grindstones, gasoline engines have proved by a wide experience to be entirely satisfactory. For threshing machines it is still an open question, for the smaller engines have so far recommended themselves better than the larger ones.

Stationary gasoline engines should be bolted firmly to a base of rock and mortar. If they can make the base tremble their work will not be satisfactory. In this locality practically all the country newspapers are printed with gasoline en-

gines, and sometimes a balky engine on an upper floor never gives a particle of trouble when it is removed to the lower floor and made solid. For small engines the style which uses the oil cooler instead of the water cooler has advantages, for water will freeze in the tank sometimes and cause much trouble. If a water cooler is used and it be a stationary engine, the best way is to have the water in the cistern or a tank and let the engine pump it for cooling, the water running back to the cistern to be used over and over again. The cistern is out of the way, and it will not freeze.

Small engines are usually more serviceable on the farm if portable and mounted. Even ordinary trucks work well, and shredding, wood sawing, etc., can be done anywhere. A few farmers can unite in buying a shredder of moderate capacity and a gasoline engine and circular saw

and change work and get their jobs done with no cash outlay but for gasoline, and suit themselves as to the time to do it.

The dairy farmer, however, needs an engine all to himself. He should have a farm separator, and should separate every day, of course, and so he needs the engine night and morning every day in the year, and he can use it for other purposes the rest of the time as desired. Some dairy farmers rarely move their engines, finding so much use for them around the dairy house that they depend upon traveling outfits for heavy work, threshing, etc. The ease of operating, the cheapness, the saving in work, the freedom from danger of fire, the compact form and small room required, and the readiness with which it can be started and stopped give the gasoline engine a great advantage over other kinds of motive power for the farm.— E. C. Bennett, in *Iowa Homestead*.

THE NEW-DUR EXPLODER.

It seems incredible to many people that the size of the spark in gas engine ignition has anything to do with the result, and some suppose that advancing the spark compensates for the small size, but this is not true. It seems to be quite well demonstrated that there is an explosive effect distinctly different from mere expansion, and if this explosion with consequent high pressure can be produced when needed, more power results than when simply ignited. Why there is a difference, one can only guess, but Mr. C. E. Duryea thinks that it is probable that in the case of the explosion the gases have sought a new relation, but have not had time to fit themselves into their new places, whereas in ignition pure and simple this change of condition is a progressive one, so that the extreme expansion at one point is modified by the final or minimum expansion at some other

point. Imagine, for example, a spoonful of sugar in a glass of water; the sugar being solid, displaces its bulk of water, but as soon as it dissolves it apparently enters the crevices in the water without perceptibly increasing the bulk.

It is well known that rapid crystallization is never so regular and beautiful and probably not so compact as that which takes place more slowly.

The "New-Dur" exploder shown herewith has been invented to explode (detonate) each charge of a gas engine instead of merely igniting it. That it does this, the size of the spark, the theory of construction, the testimony of its users and the results derived from it, all demonstrate.

It is not a magnetic spark plug and differs from all devices of this kind heretofore offered either for domestic gas lighting or for engines. The spark is produced

at a pre-determined instant and is not affected by the rate of vibration, sometimes early and sometimes late. When the circuit is connected, the exploder magnet instantly closes the sparking circuit through the spark coil and when the circuit is broken, the spark coil circuit instantly breaks, discharging its full intensity, made even more intense by the discharge of the magnet. The result is a

cuit. The magnet instantly attracts the armature and forces the reciprocating spark pin firmly into contact with the adjustable sparking point, thus closing the sparker circuit. This permits a flow of current through the coil, thence to binding post 2 and through the armature and sparking pin to the engine and ground wire of the generator. The resistance of the magnet winding is so great that but little current flows through it, which forces almost the entire output of the generator through the coil, thoroughly saturating it. When the magnet circuit is broken by the commutator the armature is released and flies back quickly under the action of its spring till it strikes the head of the sparking pin, (still held in contact by a light spiral spring) and knocks it out of contact with a velocity exceedingly great, due to the extreme lightness of the needle and the rapid movement of the armature. The superior results of the hammer-blow make-and-break are much improved by the fact that never before has the moving part been as light and susceptible of such rapid movement as in this device. The entire strength of the current is available to

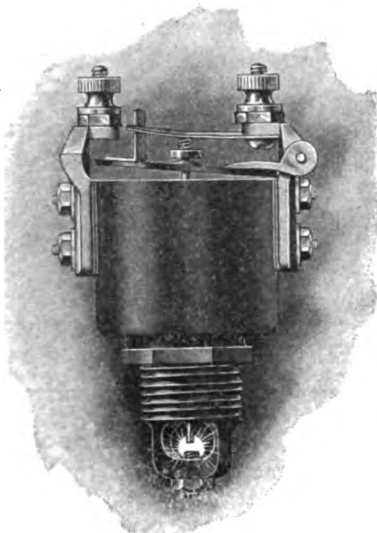

The New-Dur Exploder.

spark superior to anything before shown for the purpose; with easier starting, greater power, steadier running, less misfires and less jerking and straining of the gears, chains, bearings and other parts.

The accompanying diagram shows an exploder connected to one brush of a triple commutator, with wiring indicated for other cylinders and to the generator. Any suitable source of electricity may be used, but unless otherwise ordered, the exploders are wound for regular direct current magneto. From the generator, the electric current flows, when connected by the commutator, through binding post 1 to coil of the magnet, finally grounding on the shell of the magnet and returning by the way of the engine and the ground wire of the generator to complete the cir-

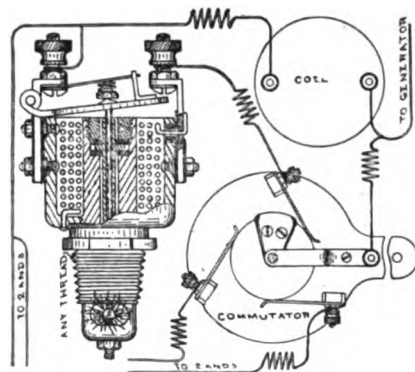

close the contact and since magnetic pull increases inversely as the square of the distance, the contact is always firm and sure in spite of oil or soot. Once in contact, an infinitesimal amount of current

suffices to hold the armature because of the short distance and the very great pull exerted by the magnet when once closed. This permits nearly all the current to saturate the coil, giving the largest spark possible even with a weak current. The breaking of the magnet circuit throws all the current through the coil, charging it to the fullest as the magnet discharges and in addition throwing into the coil the intense discharge impulse of the magnetic circuit, actually compounding the effect.

The device is made by the Duryea Power Company, Reading, Pa., who state in a recent letter:

"The one thing difficult to understand is that magnetic plugs as heretofore constructed can not give the best spark under all conditions. All magnetic igniters

heretofore used are held in contact by a spring, which must be strong to avoid interference by soot or any light resistance. If this spring is strong, a strong current is required to make the magnet break the circuit. If the spring is weak, the circuit is broken before the coil is saturated, with the result that the spark is weak in either case and does not compare with an ordinary make-and-break spark. In our device the magnet circuit receives the full strength of the battery until the sparking circuit is closed, after which the sparking circuit, because of its less resistance, gets the greater portion until the magnet circuit is broken, then the entire current with the kick of the magnet discharge brings the intensity of the coil to the highest, resulting in an enormous spark."

SOME LARGE GAS ENGINE WORK.

Two 4,000 B. H. P. gas engines direct connected to gas compressors were erected last summer by the Snow Steam Pump Works, of Buffalo, N. Y., at Pine Grove, W. Va., in the plant of the Hope Natural Gas Company. These pumps take the gas from the wells at a pressure of about 100 pounds and compress it to from 250 to 325 pounds to enable it to be delivered through about 170 miles of line to Cleveland, O. One of these pumps has been in operation most of the time since last July, furnishing gas to Cleveland and smaller Ohio cities.

Larger yet are three engines which the Snow works have under construction for the California Gas & Electric Corporation for use at its San Francisco plant. Each of these is to be suitable for direct connection to a three-phase, 400-kilowatt, 25-cycle generator operating in parallel with one or more similar units, and must be capable during load peaks to develop 5,333 B. H. P. They are to be of the four-

cylinder, twin-tandem, double-acting type, with cranks at 90 degrees to each other, and are to operate at a piston speed of about 800 feet. They will use a gas manufactured from California crude oil under the Lowe process, and containing some 632 B. T. U. to the cubic foot. The first of these engines is to be shipped on April 1; the second, June 1, and the third, August 1, of this year. The entire station equipment, including exciters and starting air compressor, will be operated by gas engines, all to be furnished and built by the Snow Company.

The same company has recently shipped and has practically completed the erection of seven gas-engine-driven gas compressors of 1,000 H. P. each, which are to be used for pumping gas to Columbus, Zanesville and many other smaller Ohio cities. Four of these are for the Logan Natural Gas & Fuel Company, and the other three for the Ohio Fuel Supply Company.—*Power.*

ANSWERS TO INQUIRIES

It is our purpose to answer in this column inquiries of general interest which relate to the gas engine or its accessories. The questions will be answered in these columns only, and we reserve the privilege of refusing to answer any question which is not, in our judgment, of interest to the subscribers of THE GAS ENGINE.

All matter intended for this department should be addressed to The Editor of THE GAS ENGINE, Blymyer Building, Cincinnati, Ohio. The name and address of the sender must accompany the inquiry in all cases as evidence of good faith. The initials only of the sender will be published, together with the postoffice and state.

Write on one side of the paper only, and make all sketches and drawings on a separate sheet. Mark each sheet with the name and the address of the sender.

(a) I would like to know what are the correct dimensions of the crankcase inlet, cylinder inlet and exhaust port for a high-speed two-cycle auto engine 4½-inch bore and 5-inch stroke. (b) What should the water jacket space be and also diameter of inlet and outlet pipes? (c) What should the compression space be? (d) I intend to place the spark plug on the inlet side of the cylinder, and when the piston is at the end of the compression stroke it will be cut off from the rest of the compression space, except by a space of ¼-inch between the end of the deflector and cylinder head. Would it work successfully?
J. D. S., South Bend, Ind.

(a) Crankcase inlet 1 1-16-inch by 1¾-inch; cylinder inlet ⅝-inch by 2-inch; exhaust 15-16-inch by 2-inch. (b-c) Water jacket space ½-inch; inlet 1¼-inch, outlet 1½-inch, compression space 1 7-16-inch long. (d) Place spark plug in the center of the cylinder head for best results.

Would you please give me the size of ports for two-cycle motor 2½-inch bore, 3-inch stroke to extend 2½-inch at right-angle to piston running at 1200 r.p.m. or

more? (b) Which is preferable for high-speed motors with touch spark ignition, an igniter mechanically operated or operated by piston?

J. H. C., St. Louis, Mo.

(a) Inlet port ⅜-inch by 1½-inch; exhaust port ½-inch by 1½-inch; inlet port to crankcase 9-16-inch by 1¼-inch. We do not believe anything could be gained by extending the port any further around the cylinder as you suggest. (b) The hammer break igniter operated from the outside is much the more satisfactory, but jump-spark ignition will probably give you more satisfactory results.

I have an engine that requires a spark coil with three wires. The coil is worn out. I have a spark coil with two poles and wish to know how I can wire for the two-pole coil.
F. D. C., Cocoa, Fla.

The two-pole coil is evidently a primary spark coil and will not answer for jump-spark ignition. Your best plan is to secure a new jump-spark coil.

I have a small two-cylinder automobile engine which is a four-cycle air-cooled, size of cylinders 2-inch by 5-inch, and fitted with a piston make-and-break igniter. (a) Do you think the motor could be installed in a small boat to run with any sort of satisfaction? I can cool it with a small fan. If you think it could be done, what size two-blade propeller would you advise and at what speed? (c) What H. P. would it develop at that speed?
J. E. H., St. Francis, Fla.

(a) There should be no trouble with the engine in a small boat provided a fan was used to cool it. (b) As the bore and stroke of the engine is so unusual we believe some mistake must have been made in the measurement. Making a rough guess we should say about an 18-inch

two-bladed propeller. (c) Not being sure of the bore and stroke we could hardly tell what H. P. the engine would develop.

What power will be developed by a 4¾-inch by 6-inch engine at 450 r. p. m.?
E. C. D., Mt. Oliver, Pa.

From 3½ to 4 H. P. for a four-cycle engine.

I have adjusted the vaporizer of my 3 H. P. two-cycle marine engine so it shows a blue flame at the relief cock in the dusk of the evening. When I stop, I switch off the current and then close the cock in the gasoline pipe, the fuel valve remaining untouched. I land, drag in the boat, turn on the current, open gasoline cock and at the first turn the engine starts, with the third explosion in the cylinder the fourth charge is ignited in the crankcase when the inlet port is uncovered, I hold that the crankcase ignition is due in this case to the excess of fuel in mixture on the third charge. Am I right, if not, why?

L. K. Smith, Grant, Fla.

This is the first time we ever heard of surplus of gasoline causing crankcase explosions. Usually they come from a weak mixture or too late ignition. Possibly if you have an igniter with variable lead your engine speeds up in the first three revolutions to make the lead too late and causes the crankcase explosions, or it may be that for some reason the first few explosions empty the crankcase and that the speed of the engine is not sufficient to draw in a good mixture.

Would you consider a 1-inch pipe large enough for intake of a 4-inch by 5-inch engine run at 600 r. p. m. if the admission valve is 1⅜-inch diameter?

G. B., Kenosha, Wis.

No. A 1-inch pipe is too small in area for the intake. If the piston speed of the

for about 1 sq. in. We believe you would get better results with a 1¼-inch pipe.

I have designed a cylinder making it air-cooled, using 16 flanges 3-32-inch by 5-32-inch by 1¼-inch. According to some engineers the width of the flange should not exceed 10 or 15 times the thickness, and I have used the average thickness and made the width equal to 10 times it. (a) Do you think I can keep the cylinder cool at 800 r. p. m. by the use of these flanges and a blower, delivering air at the exhaust and also on edge of each flange and at top? (b) I have used a spherical construction of piston and would like to have your opinion of it. It is certain that it would take a ball of gas ignited in center less time to be completely ignited than a layer of gas ignited on one side, and I have endeavored to use this principle by dishing the piston head. What weight flywheel should be used for a three-cylinder engine of these dimensions, 4.5-inch by 4-inch, to be 14-inch diameter? Would a 50 lb. rim be sufficient? (c) I have used a rather large exhaust, 3-inch by ¾-inch, using a formula for exhaust calling for about 2 by 13-16 inch. I have two transfer ports opening into the cylinder amounting to 3-inch by ½-inch, endeavoring in this way to reduce the tendency of the live gas to mix with the burnt gas. (d) The inlet to the crankcase is 3-inch by ⅝-inch. Would a large carbureter having two mixing valves be large enough to use for this engine, or should three smaller ones be used? (e) Will there be any advantage in using an automatic timer, the speed of the engine controlling the position of the contact and governing by throttle alone? (f) What H. P. should I get from a three-cylinder engine composed of cylinders like one in sketch? I have figured on 15 to 20 H. P.

G. G. J., Alleghany, Pa.

(a) There is no reason why you should not keep the engine cool if you have sufficient air current, although we believe it would have to be a pretty large blower to answer for such a large bore. (b) We are in doubt whether a spherical construction of the head will answer for a two-cycle engine, although it is certainly the best for a four-cycle. The position of the spark plug will probably give you trouble with sooting. We would suggest at least a 100-lb. flywheel. (c) For a piston speed of 800 ft. per minute, which is usual in an automobile engine, your exhaust is none too large. The proportions you refer to are for a 4-inch bore, and even this would be a little small. The size of your transfer port is also about right. (d) We

should increase the size of the inlet port in the crankcase, making the three openings 1-inch by 11-16-inch. Your vaporizer need not be any larger than would be necessary for one cylinder, provided the cranks are set at 120. We would suggest a vaporizer with compensating shutter rather than a mixing valve. (e) We believe that an automatically governed timer is a very good thing; however, it should be subject to hand control as well. (f) 24 H. P. at 1200 r. p. m. In general we should say that very much better results would be obtained by using 4-inch bore by 4½-inch stroke or similar proportions if higher power is desired. An engine of that size should give you 20 H. P. at 1200 r. p. m.

GAS AND GASOLINE ENGINES FOR COAL MINES.

The use of gas and gasoline engines for power purposes has been rapidly developed within the past few years, so that at the present time their use is no longer an experiment, and with the manufacturers of gasoline engines that stage is long since past, their object at the present time being to adapt the gasoline engine to as many uses as possible. In examining almost any catalogue of the leading manufacturers, one not familiar with these machines will be surprised to find to what extent this has been accomplished, as well as the combination in which they are made up. They are to be found successfully furnishing power for grain elevators, flouring mills, electric lighting, modern shops, combined with pumps for water works, hoisting machinery, air compressors, marine engines, and an almost endless variety of uses. And, where economy is an object, the gasoline engine, as it is called, will be found in favor, being not only economical, but safe, durable and simple, and can be run on gasoline, distillate, or crude oil, and so being adapted to

the fuel of almost any section of the country. Not only, however, is the economy of fuel an important factor in which the gasoline engine has to do, but in the attendance they require, skilled attention not being constantly required as with other motive power.

In connection with mining, it has been demonstrated that, notwithstanding coal costs nothing for fuel, still there is an economy in using a gasoline engine for power at the mines, and they are being successfully used for hoisting, pumping and running blowers, as well as the usual other machines about the mines. There are mines where these engines are located far down in the earth close by the seeps of water and are constantly and almost without attention sending the water to the surface hundreds of feet away, and at a very small cost of fuel or attention. At the same mines will be found another combination of gasoline engine and pump on the surface doing its duty in drawing water from the deepest excavation.—*The*

Inland Operator.



Ever since the automobile type of motor has begun to be developed, and ever since the automobile began to come into use, there has been an increased demand for a reliable handbook on the subject of the gasoline automobile. In another column will be found more general announcement of a new book by Mr. E. W. Roberts, "The Automobile Pocketbook." Mr. Roberts is too well known to the readers of this magazine, especially the older readers, to need any introduction. Whatever he writes is sure to be of interest and, what is possibly more essential, is sure to be of great value. The new work will be found of invaluable assistance to the designer, user, or prospective purchaser of a gasoline automobile.

Judging by the interest exhibited at the shows in the motors, the automobile buyers are acquiring more knowledge in regard to this most essential part of the automobile. While recognizing the value of efficient transmission, durable tires, etc., yet the engine is the essential portion. Trouble with the working of the engine is felt so immediately and so seriously that the successful automobile must have an engine which will give as little trouble as possible. The buyers recognize this, and most of them are going a step farther. They realize that for an automobile to be successful it must have the proper care and attention. Therefore the mechanism of the engine and other parts must be such that the operator can

understand it. The purchaser of a car is therefore appealed to by any car which appears to be so built that it may easily be understood by the operator. Along this same line is the increasing accessibility of parts, which aid in a study of the car, by being easily reached, as well as permitting of repairs with comparative ease.

General Greely, Chief Signal Officer in the United States Army, recommends, in his recent annual report to the Secretary of War, the continued experimenting with automobiles as parts of telegraph and balloon trains. He does not consider the automobile in its present state adapted to general transportation in the field. He remarks that the type equipped with internal combustion engines has especially valuable features from a military standpoint in that the quantity of fuel and water necessary is small.

One of the novelties in French automobiles is a complete car containing a kitchen, dining room, sleeping room and engine room. It is 32 feet long and mounted on solid wooden wheels. It is claimed that a speed of 20 miles per hour can be attained, the motor being of 20 H. P.

The French Admiralty has placed upon the rivers of the French Congo a police boat, 97 feet in length, equipped with two 30 H. P. engines. She is armed with quick-firing guns.

SOME NOTES OF THE CHICAGO AUTOMOBILE SHOW.

Among the new cars shown at the Chicago show that of the Adams Co., of Dubuque, Ia., is one that attracts special attention. The engine is a three-cylinder, air-cooled motor and revolves around a stationary shaft, placed vertically. The cylinders are bolted together, and to a cast steel flange with bronze bushings, forming bearings around the crankshaft. The air cooling is assisted by the cylinders revolving at a rapid rate, drawing in air at the center and expelling it rapidly at the ends of the cylinders.

In the Franklin cars mechanically operated valves and an auxiliary exhaust have been adopted.

Four cylinders in one casting is the feature of the Hammer Motor Co. It is rated at 24 H. P. The cylinder casting is made without a water jacket, which is supplied by one aluminium casting covering the upper portion of all four cylinders.

The Holsman automobile has a 10 H. P. double opposed motor, air cooled. The cylinder heads screw into the cylinder. Vane spokes in the fly wheels assist in the cooling.

The Dayton Electrical Mfg. Co. shows a new timer for multi-cylinder engines. A year or so ago there were few of these on the market, and the demand for a device of this kind has called forth several makes.

The combined two and four-cycle, three-cylinder engine of the North Chicago Machine Co., is a novelty. Intended to operate as a four-cycle under ordinary conditions, the two-cycle feature is used when great power is required, as in hill-climbing in an automobile, or in a heavy current in a boat. The operating mechanism is in the cam shaft, which may be shifted longitudinally by means of a clutch engagement at the two-to-one gear, so

that the valves may be timed and the spark made to operate the motor as a four-cycle motor. Shifting the cam to another gear wheel puts the motor into time with the main shaft and thereby gives each piston an impulse at each revolution. This is accomplished by means of the cam shaft operating the exhaust valves.

The "New-Dur" exploder, which is described more completely in another column, is shown by the Duryea Power Company.

The Frayer-Miller car, having the blower system of cooling, is an illustration of the fact that air cooling appeals to users of engines and that the satisfactorily air-cooled engine has some talking points which influence buyers. Air cooling is undoubtedly an advantage where it is successfully accomplished. What the public is demanding is to be shown that the various systems do not possess disadvantages which overbalance the account.

The Continental Engine Co. showed their line of engines, which are more fully described elsewhere.

Five hundred sparks per minute are claimed by the Duplex Coil Co. for their new coils. Two cores, two primary and two secondary windings are used, connected as one unit.

The air cooling of the Mahoning Motor Car Co. is accomplished by stringing, in spiral form, triangular copper wire on a copper ribbon $\frac{3}{4}$ -inch by 1-16-inch. Under pressure, the wire is then wound about the cylinder. Finally, by electroplating, there is secured a firm metallic connection between the cylinder wall and the radiating materials.

In a coil shown by J. M. Wilson a low-tension alternating current of high fre-

quency is used, being fed continuously to the primary coil. The reversals in the current are transformed in the coil into sufficient voltage in the secondary circuit to cause a hot flame in the cylinder. A powerful magnet furnishes the current.

The Remy Electric Co. show their magneto alternator for jump-spark ignition. In the device for a four-cylinder motor the speed is the same as that of the motor. Two impulses for each revolution of the armature are necessary, and as the armature is rotated a double cam operates the points breaking the primary circuit and causing a high tension current

to be delivered to the segment in the distributor. The segment is so set that when the cam breaks the primary it is directly in front of one of the terminal wires leading to a cylinder, but the segment does not touch the terminal, rather acting as a spark gap. Provision for timing the spark is provided by mounting the driven gear, which is upon the magneto shaft, on a sleeve. The magneto shaft and sleeve are slotted helically in opposite directions, and, by moving the swivel axially along the shaft, the angular relation of this driven gear to the armature is changed.

SOME TENDENCIES OF THE PARIS AUTOMOBILE SHOW

As long as it continued to be the case that automobile builders brought out radical improvements on their cars each year, the annual automobile shows were watched with eagerness to learn what novelty each exhibitor might have to show for the coming year. But as the automobile began to assume certain well defined features this novelty began to decrease each year. And every succeeding show seems not to have a larger proportion of novelties than had its predecessors.

Not that changes and improvements are not made each year, and not that novelties are not shown each year, but the tendency is against radical changes in methods of construction. For instance, side entrances to the tonneau are admitted now to be a feature which will soon succeed entirely the rear entrances. This change did not occur radically in one year, but last year the tendency was seen and this year it is even more evident. And so the automobile shows give the observer an idea of the tendencies of construction, which are therefore eagerly looked for.

At the Paris salon in December there were some novelties and some tendencies for the visitor to see, but not the wide variations that have marked some of the earlier exhibitions.

For instance, singly cast cylinders seem to be growing in popularity, owing to the ease with which they may be cast and machined, as compared with the two cylinder castings. Not only this, but the assembling and removal of singly cast cylinders is easier.

The tendency among European makers to adopt the mechanically operated inlet valve has been confirmed, and there were few automatic induction valves shown.

Again high-tension magneto ignition is very widely adopted. On at least one car an exhaust pot similar to that used in stationary service in this country has been used, and the exhaust pipe from the pot is six inches in diameter. Still another car had a water jacketed exhaust pot.

A few cars were equipped with copper water jackets. The Moto-Bloc car, which hitherto has had inclined cylinders, has adopted the vertical type. Double

ignition was adopted by the Darracq firm.

In a new type of gasoline electric car a four-cylinder engine has an elastic coupling with a dynamo which also serves the purpose of a fly-wheel. The shunt wound generating dynamo is rigidly connected with a transverse brace. The power developed by this generating plant is distributed direct to two motors gearing on to the back wheels.

A Belgian firm exhibited a car in which they had done away with a change speed mechanism, depending entirely on the throttling of the motor to give the various speeds. Quite a number of foreign built cars and a few American cars are advertised as having this flexibility of control, but this is the first instance of which we know when the makers had sufficient confidence in their claims to dispense with other change speed devices.

Regarding frames, by far the greater proportion were of the pressed steel type.

The tendency is undoubtedly to multi-cylinder engines, as was shown a year ago, and this has caused the general abandonment of the horizontal type of motor.

Ball-bearings are used by the Hotchkiss Company, the only bearing without balls being the connecting rod. Even the crank-shaft is equipped with the ball-bearings.

Carburation is one of the subjects which has not assumed a standard position and the tendency of last year toward a truly automatic carbureter was again shown this year. Hot water jacketing the carbureter has been employed in a number of cases.

The Decauville carbureter has the usual float feed chamber connected to another cylindrical chamber by a short length of tube. In this latter chamber

is placed a valve, adjustable by means of a thumb-screw. This valve is set once for all to regulate the quantity of fuel passing to the bottom of the cylindrical atomizing chamber, and when its proper position has been ascertained it is there secured by a lock-nut. Air is admitted through gauze at the sides of the bottom of the mixing chamber. Above the gauzed opening is set a movable cup forming a seat for an elongated cone, the top of which terminates in a stem, which projects through the cover and there carries a milled thumb wheel. The lower end of the cone has a stem passing through the cup and the air space, and rests on the bottom of the chamber. The cone is of considerable length, and is formed with fine grooves over the whole of its surface. When the suction of the engine pistons are felt in the mixing chamber the effect is to induce a perfectly proportional inflow of gasoline and air to the cup, whence they are sucked up in impingement against the grooved surface of the cone, the gasoline being thereby very finely pulverized. The effect of the piston induction is to create a depression above the cone that largely facilitates the inrush of air and spirit. The quality of the mixture being always constant, the quantity is regulated by raising or depressing the cone. The mixture is complete before it reaches the cylinders, and the entire absence of internal resistance to its flow enables the engine to obtain the fullest possible charge of gas.

In another type of carbureter there are two jets and jet chambers, one considerably larger than the other, the apparatus containing a simple method by which when the engine exceeds a certain speed the second jet and jet chamber are more or less brought into operation as required. The carbureter is hot-water jacketed.

In the Chenard & Walker cars the variable lift of the inlet valve has been abandoned in favor of a further modification of an automatic carbureter. Instead of the continuous vertical movement of the air and gasoline valve, this valve is now made so that it lifts permanently, rising higher or lower as the speed of the engine rises or falls, but does not close and open on its seat in response to every suction stroke as heretofore. The lift of the combined valve is also controlled from the wheel, so that it may be said to act as a maximum speed governor. With this carbureter the velocity of the air over the jet is always the same, and when the valve lifts to afford more air the gasoline aperture is increased in the proper proportion.

The Panhard engine is not fitted with a governor in the ordinary sense of the term, but has a piston throttle valve operated by the circulating pump through the means of a diaphragm and spring. The mixture itself on its way to the cylinders is controlled by this hydraulic governor, and not the air admission to the carbureter.

In a two-cycle two-cylinder and four-cylinder gasoline motor shown the pistons travel over two segmentally sectioned hollow guides placed opposite each other, and over which the piston fits. These guides communicate with the induction pipe through orifices in the cylinder walls and a two-storyed chamber attached to the jet chamber, in which a non-return valve is placed. The upward movement of the piston sucks a charge within its cavity as it rises, and upon the descent of the piston during the cylinder charging stroke this charge is delivered through the hollow guides and the non-return valve to the induction pipe, and into the cylinder through the usual automatic valve. On the compression stroke the hollow piston is again charging itself with mixture from the carbureter, and upon the explosion stroke a fresh charge enters at the top of the cylinder, chasing out the burnt products at two ports in the cylinder walls, uncovered by the travel of the piston towards the end of its stroke. The piston therefore acts as a suction and delivery pump for the mixture.

THE AUTOMOBILE POCKETBOOK.

"The Automobile Pocketbook," by E. W. Roberts, is a new book which will, we are confident, find a hearty reception. Mr. Roberts, as is known to most of our readers, was editor of THE GAS ENGINE during the years 1901 and 1902. He is the author of a number of well-known books on gas engineering, among others "The Gas Engine Handbook" (which is now in its fifth edition), "How To Build a 3 H. P. Launch Engine." "Gas Engines and Their Troubles." etc. For several years past Mr. Roberts has been devoting considerable time to the gasoline automobile and is recognized as an authority on the subject.

The contents of the book cover practically every subject in connection with the gasoline automobile. In the thirty-four chapters are included the subjects of automobile engine cycles, fuel-mixing devices, ignition, speed control, care of the engine and automobile, engine design, engine troubles, transmission systems, axles, wheels, tires, steering devices, emergency repairs, etc.

The book will have over 300 pages, 3½x4¼, with over 50 diagrams and illustrations. It will be bound in limp leather, and the price is \$1.50, postpaid. It is now in press and will be ready for delivery the second week in March.

"CONTINENTAL" ENGINES.

This is often called an age of specialization and The Continental Engine Co., Fisher Building, Chicago, Ill., assert that by concentrating their efforts along the line of gas engines and gas engine transmission they have been enabled to produce engines and transmission which conform to the best practice in any individual requirement. The engines of this company are made in various styles.

The type A, 28-32 H. P. motor is of the four and six-cylinder vertical type, having cylinders cast in pairs and valve chambers collectively placed on one side so as to utilize but one cam driving outfit, and thereby simplify the accessibility, the piping arrangement and the lubrication provisions.

The valves are all mechanically operated to avoid any irregularity in duplication, and to insure a reliable and economical operation by virtue of non-sticking valves that never fail to seat properly or to give identically the same results and the same supply of fuel mixture under the different conditions that a motor of this nature is naturally subjected to. The crank is entirely of hard aluminum.

The type B 18-22 H. P. is a four-cylinder vertical motor with singly cast cylinders, having small water space and getting an equal expansion and cooling effect which is very necessary in engines of small bore.

In this type, in connection with the end bearings, there is a crankshaft bearing between every pair of cylinders, distributing the total bearing area to the greatest possible extent with the shortest possible individual bearing length. This construction insures an extremely smooth and restrained running motor with properly aligned and locked bearings.

Type C is a triple-cylinder engine rated at 12-15 H. P. The cranks are set at 120

degrees, giving impulses two-thirds of a revolution apart. The makers claim that the efficiency of this engine is slightly above that of the four-cylinder type.

Type D is a three-cylinder air-cooled engine. A four-cylinder motor of the same bore and stroke, $3\frac{1}{2}$ by $4\frac{1}{2}$, is also made. The cylinders of these types are machined both inside and out, fitted with specially, die stamped, flange, copper radiating fins and separate cast socketed heads. The valve chambers, cast integral with the heads, are so constructed as to give easy access to all valves for their inspection and removal. The crank case and cover to these motors are cast entirely of nickel aluminum, with separate compartments for each cylinder, to insure

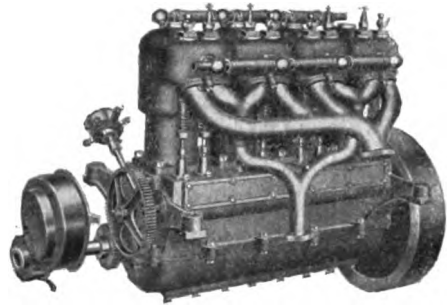

Type B.

oil retention beneath each, at all times and under all conditions.

Type E is a double-cylinder, 10-12 H. P. motor, which, owing to the few parts, small space occupied and comparatively low cost, is recommended for certain classes of marine and special work. Types F and G are double-opposed motors.

Type H is a four-cycle, "concentric cylinder" motor, for which two-cycle results are claimed. This type is manufactured under letters patent and virtually a concentric two-cylinder interposed motor, having a double trunk piston of two diameters located within the aligned cylinders with but one connecting rod and crank.

The operation and working of the motor are such that when the vehicle or boat requires but a minimum of power, as is the case under ordinary conditions of working, one of the cylinders (or both alternately) can be switched out from working without destroying the cycle of operation or balance, and thus prevent running cylinders under light, inefficient, noisy load, yet give adequate reserve power facilities for heavy going, as in hill-climbing, soft roadbeds or heavy seas.

A two-cycle, type I, $1\frac{1}{2}$ -2 H. P., is an entirely new production. This engine in combination with a mixing valve secures a speed of 850 r. p. m. Within the fly-wheel is contained a governor reverse that will automatically reverse the engine without shutting down, when the circuit breaking trigger on the operating handle is thrown. This is accomplished by virtue of the fact that the governor re-establishes the electric circuit to the ignition outfit at a certain speed, causes an explosion and kicks the engine back the reverse from which it was running. The speed of this motor is controlled entirely

by shifting the operating handle, which in turn controls the timing of the spark. The jump spark system of ignition is used and the manufacturers say they can safely run this motor at 850 r. p. m. without missing any explosions.

The mixer valve shuts off automatically when the engine is shut down and has a mixing plate at the bottom of the mixing chamber that prevents any liquid rushing to the engine without being thoroughly mixed with the air. This feature of the mixing valve has enabled an increase from the former speed of 200 r. p. m. without sacrificing the explosiveness of the mixture and without causing any back firing into the crank chamber that is so detrimental to this type of engine.

The Continental Engine Co. makes a specialty of furnishing manufacturers and users of gasoline power outfits the products best suited to their requirements, and to this end they have facilities which they state will enable them to furnish such outfits at prices that are usually charged for stock engines and transmission.

C A R B U R E T E R S . *

It can not be denied that, of the various adjuncts to the motor proper, the carbureter is of primary importance. It is the very lung of the motor, and upon its behavior chiefly depends the results obtainable from the engine.

The function of a perfect carbureter is to allow the engine on the suction stroke to take into the cylinder, at all speeds, a full charge of maximum weight and of the best proportions for obtaining the maximum power. Bearing this in mind, the chief feature of a perfect carbureter

would be:

1. Absence of throttling of wire drawing under all conditions.
2. The provision of the best firing mixture under all conditions.
3. The maintaining of the charge at as low a temperature as possible without allowing freezing to occur.

To comply with the first requirement, no part of the air passage through the carbureter should be of smaller area than that of the effective opening of the inlet valve, and the shape of the passage should be such as to put a minimum of resistance on the passing air. That is to say, the passage should be straight, and as far as possible smooth, and the sum of the areas of the various air intakes should be more

*A paper read by Mr. E. W. Walford before the Automobile and Cycle Engineers' Institute at Birmingham on January 19th.

than equal to the area of the valve opening.

To comply with the second requirement, the so-called "automatic" carbureter has been produced. The chief condition affecting the carbureter in this respect is variation of pressure in the carbureter chamber due to variation in engine speed, throttle opening, etc. The chief reason for this is a simple one. The air being an elastic fluid varies in weight, decreasing with the increase of suction, whilst the weight of the gasoline is constant. There are other reasons, but this is the main one. The result is that when suction is high too much gasoline is taken from the jet, and vice versa.

There are then two types of automatic carbureters:

1. That in which the air supply is varied as the suction and pressure varies.
2. That in which the fuel supply is throttled or baffled as the suction increases, such as the Dunlop, the air intake being fixed.

In the variable air intake type it is obviously advantageous to have as small a number of air intakes as possible—preferably only one. That means that the air intake should be located behind the jet. There are two ways of doing this. The air intake may be varied at the jet or some distance from it. In the first instance, the velocity of the air passing the jet is kept high, and an ejector effect is set up, which draws the gasoline from the jet, and causes it to be violently broken up and well mixed. To obtain this, the area of the passage for the air past the jet must be varied according to requirements. In the second instance the gasoline is drawn from the jet merely by a vacuum and falls, dripping out at the bottom of the carbureter. Experience shows that accurate control in such a case is difficult.

In the second type of automatic carbureter (with a fixed air intake and variable jet), it is clear that the fixed passage

through the carbureter must be quite as large as the effective opening of the inlet valve. For good starting, then, the bore of the jet must be large. It is obvious that the control of the bore of the jet is most delicate—the chief point against this type. The Dunlop, and one or two other carbureters, have obstructions in their jets, which prevent the too rapid flow of gasoline at high speeds.

With any automatic carbureter the mistake is often made by the buying public of fitting the carbureter without adjusting it to the engine. They are under the impression that if it is "automatic" it is bound to do all that is required of it. In any case, there should be an adjustment on the automatic device which is adjustable while the engine is running, as many are not. This adjustment is very necessary to cope with variations of levels with different gasolines, variations of atmospheric pressure, due either to altitude, weather conditions, or both, variations in the composition of the fuel, and for discrepancies in manufacture.

The automatic device must be actuated by the variation in pressure in the spray chamber. This variation in pressure is brought about by variations in throttle opening, engine speed, and the number of cylinders being supplied. If, then, the automatic device is controlled in any way by the speed of the engine, or in conjunction with the throttle, correct results under all conditions can not be obtained, though an approximation is realized which gives fair results over a certain range.

The third requirement, that of maintaining the charge at as low a temperature as possible, is important if best results are to be obtained. When volatilization occurs the temperature in the spray chamber falls. This causes the aqueous vapor in the passing air to condense, and, unless steps are taken to prevent it, to freeze and choke the passage.

To prevent this, either the spray chamber is jacketed, and the cooling water or exhaust gas circulated through it, or the air drawn in is warmed. Of these methods, exhaust gas jacketing seems by far the best. The amount of heat passing can be controlled, while with the warm water jacket a good time is taken to warm the carbureter up, the jacket is liable to burst with frost, and the joints must all be water tight. In any type of jacketing, only those parts should be jacketed where freezing occurs, in order not to heat up the charge unnecessarily. For this reason taking the air in warm is not the best method, but it is the simplest. With small engines, warming of any kind has been found superfluous if the carbureter is sheltered behind the engine, as on a motor cycle, and any warming method is a useless complication and a power waster.

It will be seen, then, that the necessity of warming is due to the presence of water in the charge. Apart from any possibility of freezing, the presence of water in the charge is bad, as has been proved by Mr. Roots, who by passing the gas over unslaked lime obtained better results, until the lime was "saturated."

The gasoline should be fed into a well, with an outlet therefrom to the float chamber through layers of gauze. The bottom of this well should be detachable, so that water and grit collecting in the well can be removed. The passage from this well to the float chamber should be large, for obvious reasons.

The float is generally the most unreli-

able part of the carbureter. To overcome leakage troubles, it is suggested that the float should be of cork, covered with graphite, and copper plated.

The passage from the float chamber to the jet should not be led from the bottom, as any grit, and especially gummy deposits, are thus left behind. To prevent this foreign matter returning to the needle valve seat, a slight wall may be raised round it. The passage to the jet should, of course, be of large bore and be easy to clear.

The jet should be easily removable without the necessity of taking any part of the carbureter down. It is an advantage to make the jet of large bore almost to its tip, where it is drilled as required.

As the carbureter is not stationary, but is tilted in different directions, it is an advantage to have the jet in the center of the float chamber. Then tilting of the carbureter has no effect upon the level of gasoline in the jet. In all such cases, however, the top of the jet is high above the level of the gasoline, and consequently starting is not easy. The central position of the jet does not seem of very great importance, and excellent results can be obtained with the jet close up to the float chamber. In such cases, the carbureter should be set across the car with the spray chamber on the right-hand side.

These notes do not, of course, profess to deal with the subject scientifically, but only to set out some of the practical requirements, with a view of promoting a discussion.

ITEMS.

The New York City sewer department has a portable pumping plant for draining cellars, etc., employing a kerosene oil engine for operating the pumps.

We have often wondered when we would

see the toy gas engine, similar to the toy steam engine familiar to most boys. At last we learn of one on the market. Its power is "not estimated," but it will run, and to do so all that is necessary is to connect a rubber tube to a gas pipe and "light the gas."

HOW TO EXAMINE A VERTICAL MOTOR

The amateur possessing a four-cylinder motor may shrink from the task of removing the cylinders for the purpose of examining the state of the piston rings or to lighten up the gudgeon pins.

In reality it is a simple operation and easily done by any one possessing a mechanical turn of mind.

To remove the cylinders, which are usually cast in pairs, one must first detach all the wires of the electrical circuit, taking care to label them to prevent mistakes in re-erection.

If the valve tappets are all on one side of the cylinders it may be necessary to remove these to get at the nuts holding down the cylinders to the crank-case. This is, however, quite a simple matter.

Here, again, it is advisable to mark the parts or make a diagram, showing where each fitting was taken from, unless the parts are already numbered.

No two cars of a different make are fitted up in exactly the same manner, but the differences are so small that the operation of lifting the cylinders is almost identical for any type. The crank should be in such a position that both pistons are half way up the cylinders; this will facilitate the removal. The cylinders may then be wriggled off the pistons and lifted clear of the chassis.

Piston rings are easily removed by pushing two thin blades under them and slipping them off. They should be carefully handled, as they are very springy and brittle.

When the pistons have received attention, and the gudgeon pin is found to be in order it is an easy matter to replace the cylinders.

Before the parts are replaced they must be scrupulously cleaned and smeared with fresh lubricating oil. All

grit and dirt must be removed from the base of the cylinders and the top of the crank-chamber, which is generally a faced joint.

In some motors there is a tapered ring round the cylinder opening which allows the piston rings to slip in easily. If there is no taper at the end of the cylinder the rings must be compressed and each one tied up tightly with string. As each ring enters the cylinder a sharp knife cuts the string, which is then pulled clear.

With a little patience, and more wriggling, the pistons will enter the cylinders, which must be carefully lowered on to the studs or holding-down bolts.

The nuts on the holding-down bolts should be screwed down hand-tight, after giving a final look round to see that no foreign matter gets in the joint. While the nuts are still hand-tight, turn the starting handle carefully with the compression taps open and see that all is working properly.

The spanner should be used evenly and alternately on each nut.

When the last nut has been screwed up tight, and the various parts reassembled, take the same precautions of working the crank round by hand before starting up the motor on its own power.

By labeling each part all danger of connecting up wrongly is eliminated.

A careful mechanic will provide a box large enough to take the disconnected parts. This keeps them all together, and they do not get kicked about the floor.

Each nut should be replaced on the stud or bolt from which it was taken.

It only requires a little courage to make up one's mind to start the work, and it will be found much simpler than one at first imagined.—*Motoring Illustrated*.

GAS DRIVEN LOCOMOTIVES AND SHIPS.

The Berlin correspondent of *The American Inventor* gives in a recent issue some interesting facts relative to the use of gas engines in medium and large sized units for marine service. We quote the following extracts from the article:

The fact that endeavors to drive ships mechanically were made long before mechanical traction was applied to road vehicles seems to be due to the necessity of overcoming the action of winds and currents contrary to the course of the ship. In fact, the first steam railway was not started until twenty years after the first connection by steamer had been established on the Hudson River by Fulton in 1807. It is true that obstacles of a purely technical character have no doubt also contributed to delaying the development of the steam railway.

Now steam engines, which were in the beginning of a rather uneconomical operation, gradually underwent material improvements, all of which, far from constituting any new inventions, embodied, however, merely the practical realization of ideas suggested by Watt, Hornblower, Woolf, Murray, Evans and others at the end of the eighteenth and the beginning of the nineteenth century. The progress actually made is mainly due to the general technical development, allowing of a much more perfect machining of materials. The development of the steamship, which has now gone on for nearly one hundred years, was accordingly secured without any essential modifications in the underlying principles.

Of late years, it is true, there has been something in the way of a radical modification, as steam turbines have begun to replace the familiar reciprocating engine. There are, however, rather narrow limits as to the utilization of fuel, though a material progress has been ob-

tained since the origin of steam engines (when only about three to four per cent of the heat contained in the fuel was converted into effective work), it is not likely that the utilization of sixteen per cent, as secured by the best class, modern-day steam engines, either reciprocating or turbine, be ever exceeded considerably. A utilization of fuel as perfect as possible is, however, of special importance on board ships, where the store of coal carried along is an unavoidable charge, resulting in larger dimensions of the ship, which in turn requires a greater horsepower and larger store of fuel, and so on. The coal consumption is, however, nowhere of so great an importance as on warships, whose radius of action is mainly dependent on the amount of coal they carry. In fact, an engine requiring only half the amount of coal necessitated by the actual steam engine would allow of the radius of action of warships being increased by more than double.

A steady revolution is taking place in the field of stationary engines, where gas motors are gradually replacing steam engines. Whereas these motors, until some years ago, were mainly limited to small industries (being connected to the municipal gas mains), their rapid present development is mainly dependent on the utilization of blast furnace gases.

Now the idea suggested itself to utilize gas engines also for the operation of ships; in fact, the first gas ships are only just now being put into operation. Explosion engines operated by liquid fuel (benzine, petroleum or alcohol) have, it is true, long been used for small-sized boats and even as auxiliary engines for large river and sea-going vessels, though the cost of operation be much higher than with steam engines. Clumsy gas engines, designed for stationary operation,

without any previous alteration, were simply installed in large boats, to serve there as auxiliary motors. Marine gas engines proper, operated with coal, were not, however, available up to the present day.

Now, Mr. Emil Capitaine, of Frankfurt, Germany, a well-known engineer in the field of motor construction, has designed a gas engine specially intended for the operation of ships, and being available for more than 1,000 H. P., while fully utilizing any advantages inherent in the gas engine. The principles that guided Mr. Capitaine were enunciated by himself in a lecture recently delivered before the Frankfurt section of the Association of German Engineers.

As the efficiency of gas engines is most satisfactory for moderate units, it seems advisable to use several small cylinders combined rather than a single large-sized cylinder. A 200 H. P. gas engine, including four cylinders of 50 H. P. each, will, for instance, show the following advantages as compared with a one-cylinder engine: (1) the speed of rotation of the machine can be about twenty-five per cent higher, the reciprocating masses being relatively smaller; (2) the cylinder capacity can be reduced in the same proportion; (3) the flywheel masses and the power losses attendant on the uses of large flywheels will be considerably reduced; (4) a rational disengaging regulation can be used, even in such cases as require a high uniformity of working, thus doing away with the disadvantage of the gas engines afforded by the relatively less favorable consumption with smaller loads as against steam engines; (5) the first cost of the engine will be smaller, and so will the weight and dimensions of the engine and the cost of the foundations; (6) a standard, four-piston engine can be varied according to its size by twenty to forty per cent, as to its engine plants for marine purposes,

where size and weight are of paramount importance, have accordingly been so designed for powers up to an output of 1,00 horsepower.

The motors that are being designed according to the above principles by the Capitaine firm have as small dimensions and as low a weight as possible. They work at a very reasonable angular speed, warranting a satisfactory life of the engine.

The gas is generated automatically from coal or coke, in a specially-designed producer, according to amplified principles. The gas formed is washed in a finely pulverized water cloud, cooled and purified in a centrifugal apparatus and thrown in a very pure condition into a mixing valve, to be mixed there with air in the proper ratio to form the explosive gas entering the gas engine. A special device will maintain the temperature of the producer at constant figures, even with varying operation. On the shaft of the centrifugal apparatus, driven from the motor, there is at the same time a centrifugal pump serving to discharge the cleaning water used, and a similar one intended for supplying fresh amounts of cleaning water to the gas and of cooling water to the motor.

The body of the motors, which are made with either two or four cylinders, consist of wrought-iron sheets, allowing of a minimum weight with the highest stability. Both the pistons and cylinders, valves and igniters, are readily accessible by loosening only four screws. No parts of the engine have to be removed to allow of the cylinder, pistons and other organs being cleaned or revised.

The consumption of coal for each hour and effective horsepower is, in the case of a 10 H. P. motor, 0.5 kgs.; with a 30 H. P. motor, 0.40 kgs., and with a 100 H. P. motor, only as much as 0.36 kg. Calculating the price of the coal used at fifty cents per 100 kgs., the effective

horsepower in a 30 H. P. plant will work out at about two cents per hour. There is obviously required only a comparatively very small supply of coal, as compared with steam engines, the latter consuming generally $1\frac{1}{2}$ to $2\frac{1}{2}$ kgs. per hour, and effective horsepower, in the case of 10 to 20 H. P. units.

The motors are started by compressed air in the well-known way, to which effect a small compressed air tank has been fitted below the floor. The 25 H. P. motors have two cylinders, while those from 50 to 100 H. P. are fitted with four cylinders. In the case of twin-screw boats using 200 H. P. engines, a maximum output of about 300 H. P. is secured.

It should further be remembered that

no stoker is required, and that there is no smoke or smell and no risk of explosion. Whereas a 100 H. P. gas ship, as above mentioned, uses about 36 kgs. of coal, the consumption of a steamship will average about 100 kgs.

The economical bearing of a possible introduction of gas ships should not be undervalued. In fact, many millions in coal would be saved, and the waterways, on account of the cheaper operation, become much more efficient competitors of railways than used to be the case. Moreover, as further improvements in the design of large-sized gas engines are to be expected in the near future, the above-mentioned advantages may even become more striking.

ELECTRIC SPARKING FOR EXPLOSIVE MOTORS

Simple as the construction of an induction coil may seem, there are considerable difficulties to surmount. It is easy to say that one takes a bundle of iron wires and then winds round it a thick copper wire with a secondary winding of finer wire over it, and adds a condenser and the most rapid trembler possible; but to succeed in making an irreproachable coil in every way suitable to the needs of the motor without producing any sparking at the platinum contact points, you must combine the iron wire core, primary winding, secondary winding and condenser in their proper relationships.

Another interesting question is the power of the spark. Some people are of the following opinion: "Provided that the coil produces a small spark, that is sufficient." People of this opinion have obviously not reflected on the matter. The strength of the spark that you get from the coil depends upon the cubic capacity and the pressure in the cylinder. With a

coil giving a small spark, you may get good results in small cylinders and less satisfactory results in big cylinders—that is to say, an efficiency which will not be the maximum. The object in producing a spark is to fire an explosive mixture in the shortest time, so as to get the maximum combustion of the flame. To get this result you must proportion the spark to the cylinder, for if we compare the spark with a sphere we see that the surface of the spark which produces the firing varies according to the cube of the radius.

At the same time, you must not always be satisfied with having an extra rapid trembler; you must use a trembler suitable for the maximum speed of the motor. With the same expenditure of current a rapid trembler produces smaller sparks in the secondary than low-speed tremblers; therefore you get a less good effect. To use a trembler suitable for a motor running at 1,000 or 1,200 makes a very poor combination.—*The Autocar*.

TRADE PUBLICATIONS.

"The New-Dur" exploder is a device used to explode (detonate) the gas engine charge rather than ignite it. A circular from the makers, the Duryea Power Co., Reading, Pa., gives full particulars.

The Harry R. Geer Co., St. Louis, Mo., has been sending out a very complete special catalogue of engines, castings and accessories for motor cycles and motor boats.

The National Battery Co., of Buffalo, N. Y., have issued their 1905 catalogue for storage batteries, which are made for all classes of service, including gas engine ignition service.

The Hart-Parr Co., Charles City, Ia., are sending out a 12x24-inch poster showing their portable and traction gasoline engine outfits; also a folder containing testimonial letters from users of these rigs.

The new catalogue of the Advance Manufacturing Co., Hamilton, O., shows the "Hamilton" gas and gasoline engines in various classes of service. A feature of the catalogue is large half-tones, showing clearly the various parts of the engine.

The Gardner Convertible Steam and Gas Engine Co., Washington, Pa., issue a very well-printed little catalogue of convertible gas and steam cylinders and engines, as the cylinders alone may be attached to any oil well engine bed having an overhanging cylinder.

From M. R. Muckle, Jr. & Co., engineers, 512 Stephen Girard Building, Philadelphia, we have received a booklet, being a reprint of a paper by Mr. J. R. Bibbins on the Philadelphia high pressure pumping station, in which it will be remembered gas engines are used for power generation.

The "Little Wonder" is the trade name given by the Southern Machine Manufacturing Co., 731 East Carey Street, Richmond, Va., to their engines. A circular received from the makers gives particulars in regard to the engines, which are vertical, single cylinder, two-cycle engines, using electric ignition.

The Acme Gas Co. and the Strang Engine Co., both of Chicago, have been conducting experiments on a Strang 3 H. P. oil engine for some time. From a circular received from the engine company we learn that their engine was successfully tested on various low grade oils, including one imported from Borneo.

A new circular from the International Power Vehicle Co., Stamford, Conn., is printed in two colors and gives full information regarding the International kerosene oil engines, which the manufacturers claim are the "best yet discovered." Electric light and storage battery plants are made a specialty by this company.

"Power from Ordinary Kerosene" is the title of a folder from the Strang Engine Co., 140 Dearborn Street, Chicago, Ill. One type of Strang engine is horizontal, double-acting; another is vertical, single-acting with jump spark ignition. The circular states that the average consumption of fuel is $\frac{3}{8}$ pound per H. P. per hour.

The new catalogue of the Mathews Boat Co., Bascom, O., is one of the finest we have received this month. The cover is a beautiful design, showing a power boat on the water in moonlight. The inside pages are not less attractive than the cover, being replete with information relative to buoys, signals, navigation rules, as well as Matthews torpedo launches.

C. F. Sparks Machine Co., Alton, Ill., have a new catalogue on their engines, which are built in several styles and types. There is an 8 H. P. horizontal double-opposed, four-cycle, water-cooled engine, with or without propellers; a 5x5 double-opposed, four-cycle, water-cooled marine engine, and a similar automobile, air-cooled engine.

The O. K. Gas Engine Works, Winchester, O., have a circular of their vertical, single and multi-cylinder engines, which are built in units from 1 H. P. up. They are four-cycle engines, the cylinder head containing the valves is water jacketed. A relief ring is provided between the piston and cylinder head so that if the user desires to change from gasoline to gas he can increase the compression of the engine.

"The Spark That Counts" is the title of a new booklet from the Induction Coil Co., 10½ Miller Building, Milwaukee, Wis. Every gas engine compresses the mixture before ignition, and as compression increases so does the resistance to the passage of the spark increase; therefore the greater the compression the more powerful must be the coil. A number of styles of coils are shown, also spark plugs, a carbureter and a contact breaker and spark timer.

Termaat & Monahan Co., Oshkosh, Wis., have a very well-printed catalogue of their two and four-cycle marine engines. One feature of these engines is the method of operating the piston pin, the pin being held rigid in the connecting rod by means of a set screw. The pin, therefore, has its bearing in the piston, giving larger wearing surface. Two-cycle engines are built in units from 1½ to 8 H. P., four-cycle engines in larger units.

"We believe that if the principles in the operation of a gas engine were better understood by the parties handling

the engine, a great many of the mysteries and bewilderments surrounding these engines would disappear, and there would be less trouble and complaint." Such is the main idea of a circular from the Capital Gas Engine Co., Indianapolis, Ind., and in following up the explanations there are given four sectional drawings showing the operation of a four-cycle engine of the capital type.

The gasoline engine has become so essential a machine to the farmer that it is not surprising to note that more of the manufacturers of agricultural machinery are beginning to build these engines. The Foos Manufacturing Co., of Springfield, O., have issued a circular of their "Scientific" gasoline engine, which they significantly call "engineerless." Both vertical and horizontal types are shown, ranging from 2 to 10 H. P. A portable outfit is also shown, as well as a small engine on skids belted to a "Scientific" grinding mill, which should make an attractive proposition to the farmer.

"Pipe and Boiler Coverings and Their Uses" is a small pamphlet from H. W. Johns-Manville Co., 100 William Street, New York, describing various forms of Asbestos and 85 per cent Magnesia Sectional Pipe Covering, their use and value, for both steam and hot water pipes and to protect pipes from freezing. We have seen some of this pipe covering used on exhaust pipes to prevent danger of fire from contact with wood, or to prevent occupants of the room from unguardedly coming in contact with the hot pipe.

Catalogue No. 83, from Fairbanks, Morse & Co., Chicago, relates to the suction gas producer and producer gas engines built by that company.

The catalogue of the Continental Engine Co., Fisher Building, Chicago, is an excellent one, and is dedicated to him who is interested in high grade hydro-carbon engines and accessories. Several types

of engines are shown, from two-cylinder up to six, vertical and double-opposed types. A more complete description of these engines will be found on another page. Posters and lithographed cards have not been circulated largely by gas engine makers in general, although a few companies have adopted such advertising literature with good results. A poster received from the Continental Engine Co. bears the title of "Two Winners," which reference is to a young lady appearing on the card and to the Continental engine, which is also shown.

From the Smith Gas Power Co., Lexington, O., we have received a blue-print of their automatic suction gas producer, for which the following claims are made:

Uniform quality of gas maintained automatically at all loads by the use of an automatic regulator.

Very long runs on one charge of fuel.

For runs up to ten hours the only attention usually required is for one cleaning and charging for twenty-four hours, aside from this the plant requiring no attention.

Waterseal charging door, which closes the top of the producer absolutely airtight, but permits free access to the interior for cleaning and barring the fire.

Patent swinging grate, which permits the easy removal of ash and clinkers.

Highest possible fuel economy secured by the use of a patent superheater and economizer.

Smalley marine gas engines are described and shown in one of the most elaborate catalogues received by us last month, from the Smalley Motor Co., Bay City, Mich. These engines are all of the vertical two-cycle type. A port in the hollow piston admits the charge from the crank case to the passage leading to the combustion chamber. In the smaller sizes this passage opens into the cylinder

in the usual manner, but in the larger units it leads to the cylinder head, and the charge is admitted through an atmospherically operated inlet valve. Decreased fuel consumption is claimed as a result of this practice. Another feature of these engines is that the piston heads, instead of being flat as is usually the case, or curved as is sometimes the case, are oblique, the slope of the oblique being toward the exhaust port. In the small units the higher portion of the oblique acts instead of the baffle plate usually used to divert the increasing charge toward the cylinder head.

The Bruce-Meriam-Abbott Co., Cleveland, O., are sending out a series of circulars of their engines, which are especially adapted to electrical work. The engines are vertical, twin-cylinder, four-cycle engines. The four valves are located in a single head casting and are opened directly into the cylinder space. Jump-spark ignition is used, but without a vibrator on the coil. The peculiar element is the making and breaking of the primary circuit between copper pins under a bath of oil. The oil cup is adjustable in an insulated sleeve. A tapered hole in the cup receives an easily renewed taper pin. Contact is made between this pin and a taper pin fastened to a spring, which is held rigidly to the frame. The entire mechanism is adjustable around its axis for changing time of ignition. Two insulated terminals in conjunction with the rotating pin serve to ground each cylinder alternately, thus permitting the use of but one coil and but one contact maker. This system requires more ignition current than the older forms, but is found to be very much more reliable, particularly for high duty gas engine service. Spark gaps are used at the plug terminals, so that the ignition can be seen while the engine is in operation.

INDUSTRIAL ITEMS.

The Superior Tool and Supply Co., 506 East Front Street, Cincinnati, O., is putting a line of engines on the market to be known as the "Superior."

It is reported that the sale and manufacture of the Secor oil and gas engine has been acquired by the Marine Engine and Machine Co., Harrison, N. J.

Bauroth Bros., Springfield, O., recently put out some of their engines for operating meat and sausage grinders in meat shops, and report that the butchers have found these plants very much of an improvement, giving them much greater capacity from their old grinders.

The Perfection Magneto Co., Anderson, Ind., was recently incorporated with a capital stock of \$20,000. F. G. Borden, R. E. Creighton and M. K. Creighton are the incorporators. The company has been making "Perfection" ignition magnetos for several years.

The Beaver Machine Co., 222 East Second Street, Cincinnati, O., is a new company starting in the gas engine business. A specialty will be made of $3\frac{1}{2}$ to 10 H. P. engines. Mr. Beaver has been engaged for some years in the gas engine

business, having been employed by an Ohio manufacturer of engines.

Palmer Jordan, of Haddam, bought a second-hand automobile in Providence, R. I., for a small sum, and has rigged it up for sawing wood, and it makes unique and rapid work, says the *Hartford Courant*. He saws a cord of wood in from eight to twenty minutes, and then jumps aboard and runs to the next customer.

Beginning March 3 and continuing each week for a period of ten weeks, the Y. M. C. A. of Chicago will conduct a series of ten lectures on automobiles. Mr. E. W. Roberts, formerly editor of this magazine, will deliver the lectures, which will be illustrated by lantern slides and diagrams.

The Meriam-Abbott Co., of Cleveland, O., have long been known among the gas engine trade as making a specialty of electric light plants driven by gas engines. The Bruce-Meriam-Abbott Co. successors to the old company, are building engines in much larger units than the older company did, and, having installed new and improved machinery for their manufacture, will no doubt be able to increase their output considerably.

THE MARINE GAS ENGINE

The *Glasgow Herald* recently called attention to the use of gas engines as marine propellers. Some barges on German canals have been propelled successfully by this class of engine, but a more important venture is now in hand in England. Messrs. Holzapfel, on the Tyne, have a vessel of some 800 tons burden in course of construction for propulsion by engines supplied with coal gas made in suction gas producers. The coal required per horsepower per hour is much less than

with steam engines; and this and the total abolition of the bulky and expensive high-pressure steam boilers, with all their appendages, are two advantages which make the subject one of great interest. The chief objection at present to marine propulsion by gas arises from the fact that gas engines are difficult to control in speed, and not easily reversible. Several means for overcoming the difficulty have, however, been proposed. Among others, the hydraulic jet propeller has been tried.

THE GAS ENGINE.

STATIONARY—AUTOMOBILE—MARINE.

PUBLISHED MONTHLY BY

The Gas Engine Publishing Co.

Blymyer Building, Cincinnati, Ohio.

ADVERTISING RATES ON APPLICATION. Address All Communications to the Company.
Entered at the Postoffice at Cincinnati, Ohio, as Second Class Matter Feb. 20, 1899.

VOL. VII.

APRIL, 1905.

No. 4.

Domestic Subscriptions, \$1.00 per Annum.

Single Copies, 10 cents.

Foreign, \$1.50 per Annum.

A British maker proposes to put a 12 H. P. gas engine and suction gas producer on an automobile. We should think, however, that it would be some time before such outfits become at all common.

On August 18, 1904, one of our subscription agents at the St. Louis Exposition secured a subscription from J. W. Hunter, Loomis, Ill. The paper has been sent to that address regularly, and the postoffice has informed us that there was no such town in Illinois. Neither our agent nor ourselves can locate Mr. Hunter, and this notice is inserted in the hope that he, or some one who knows him, may see it and advise us his correct postoffice address. We have never received a complaint from him that the paper was not being received, and therefore supposed it was reaching him.

After reviewing the gas engine and gas producer exhibits at the St. Louis Exposition, the editor of one of the prominent literary magazines remarked that it was astonishing how the steam engine manufacturers continued to spend money experimenting with new forms and types of steam engines, when it had been shown so conclusively that the economy of the gas engine and gas producer was so great as to put the steam engine out of the running in course of time. Without considering whether or not the gas engine ever will put the steam engine out of the market, we desire to call attention to fact that many of these large steam engine builders are, as a matter of fact, taking up gas driven plants. It is well known, of course, that several of the large steam engine builders have placed lines of gas engines on the market and are now able to furnish power

plants driven by any kind of fuel or by water power. It is not so well known that other steam engine companies are preparing to do the same thing. We know of one gas engine expert who has designed lines of internal combustion engines for several of the largest Corliss engine makers in the country, as well as for manufacturers of high-speed engines. We know of other steam engine builders who have employed experts and are bringing out lines of their own, some to be operated by gas, others by crude oils, etc.

These companies have for years been building too good steam engines to jeopardize their reputations by making known their plans until they are ready to put a completely tested line on the market. In some cases the men in other departments of the plants hardly know what is being done, so closely are the plans kept under cover.

The expert in the employ of one of these companies recently said to us: "While I am not speaking authoritatively in any way, I have been thinking how well our boiler shop would lend itself to the construction and testing of gas producers."

All of which goes to show that the large steam engine builders are not asleep as to what is being done, or what is possible, with the internal combustion engine and gas producer. And we know whereof we speak when we venture to prophesy that five years from now, and even sooner, there will be classed among gas engine builders firms long since known as prominent steam engine builders, and who, even now, will not admit that there is the slightest chance of the gas engine cutting down the sales of steam engines sufficiently to interfere with the building of steam plants.

MOTOR LIFEBOATS.

A late inspector of lifeboats in the English navy recently expressed himself as follows on the subject of motor lifeboats:

"Having seen and read various reports concerning the fitting of gasoline engines to a lifeboat, perhaps it may be of interest to point out what I consider some of the advantages of a gasoline engine as fitted to a lifeboat, and also some of the disadvantages, and finally I will give some practical hints on the fitting of a motor, which are based on a long and varied sea experience, coupled with seven years of practical work with the motor car and motor boat.

"Naturally, the first impression one gets as regards fitting one of these boats with an engine is 'Its just the very thing,' because of the small space the engine occupies for its horsepower, as compared with the steam engine, also the great facility with which the fuel can be stored and shipped, the quickness with which the engine at a moment's notice can be started and instantly give off its maximum power. Besides this, the fuel can be stowed below the water line, giving stability to the boat, and should it be necessary for the lifeboat for hours at a time to stand by a vessel in distress (as is often the case), the engines can be stopped. This means that it will not be necessary to carry, in proportion to coal, so much fuel. Then again, it would be quite possible to propel these boats nearly twice as fast as any steam engine ever made, because the gasoline engine can be made much more powerful in proportion to the space occupied or required with a boiler and its coal bunkers, etc., and the speed of the engine is much higher. All this is essential, especially as regards the speed.

"On the other hand, I fail to see how the gasoline engine, if fitted to the ordinary standard portable lifeboat, can be at the 'best of times' anything else than an auxiliary help, which must not for a moment be relied on to take the place of any of the crew or gear. The very great difficulties which attend the launching of the ordinary standard lifeboat from a carriage would make it almost impossible to fit a screw to the boat. As it is, the rudder must always be triced up and pulled to one side, to prevent it knocking or catching against the fore end of the carriage on being launched.

Wherever the carriage is used for the launching of these boats, in ninety-nine out of a hundred times the boat is launched off a lee shore in shallow waters, which necessitates the use of every bit of available (human) power to enable the boat to get through the breakers into deep water.

"There is no doubt an engine would be of great service when once out and in deep water, especially if used with the sails, and so keep the boat's head up to the wind. As few of these boats are able to sail much closer to the wind than seven points, owing to the enormous side the boat and its end boxes present to the wind and waves with little or no keel.

"Again, it must be remembered that the lifeboat is almost without exception always 'called out' when a ship is unable, through the fury of the sea, to make any headway, and consequently it gets driven into shallow and broken water, on a lee shore, or on a rock.

"The engine is always working uphill, so to speak, *i.e.*, the propeller is driving against water, which naturally tends to stop or prevent the blades from revolving, and there are no radiating plates or any current of air passing through the engine to keep it cool and dry.

"Another difficulty to be overcome will be to find the man or men to look after and run the engine, as it will be necessary to have at least two of the crew (in case one is ill) to be taught to understand the practical running of motor engines and their peculiar habits, especially under adverse circumstances.

"In my opinion it would be quite possible to specially construct a boat which, besides being unsinkable, could be driven by gasoline to its advantage. But it would have to be built more on the lines of the present steam lifeboat, where the engines would be encased. In designing these boats certain deviations from the usual plans would have to be observed, and I will try and put forward a few of the essential points.

"It would be necessary to have the inlet pipe to the water circulation well under the boat, so that the engine could not suck in air instead of water, and get overheated when rolling or pitching in a heavy sea. The boards or decking, etc., round about

the engine would have to be made or covered with stuff so that the driver could get a foothold, as my experience of gasoline-driven boats is that everything gets so smothered in lubricating oil that it is practically impossible to get a foothold anywhere near the engine. This equally applies to all boats, and it is a wonder to me some kind of fabric is not used on the flooring of boats which ensures a safe footing at all times.

"A lifeboat in a seaway is one of the wettest things imaginable, and of all things that a gasoline engine dislikes, wet is the most objectionable. It is a common occurrence for a lifeboat to get filled up to the thwarts with a sea, and although it is so constructed that it automatically drains itself dry through the various draining valves placed on the deck and above the level of the water, yet one knowing the gasoline engine can not imagine it to be of any real practical service, unless it was covered in.

"In my opinion, the present standard portable lifeboat is far too cramped and crowded to allow anything else to be put into it, and to 'double bank' the oars and give room for the engine, etc., is not the same thing as one man one oar.

"A gasoline fire extinguisher would have to be carried, as any leak from the gasoline joints or carbureter, mixed with the air, would very soon become ignited, and this is the most dangerous part connected with the fitting of gasoline engines ignited by electricity. The only alternative to this would be to fit a large fan in such a position that it would draw off any accumulated vapor, and shoot it out clear of the sides.

"It would be as well to fit the engines with the low tension magneto, and not accumulators, owing to the liability of the latter to short circuit with the dampness of the salt water. This equally applies to all the parts connected with the batteries.

"The screw would have to be placed well under the boat, so to speak, and well protected by the sides and keel of the boat, so as to allow the engines to work in shallow waters, and the blades protected from floating seaweed. Two sets of four-cylindere engines could advantageously be used, each set working absolutely independently of the other, and each fitted with its own magneto, carbureters, oil feeders, gasoline tanks, etc. Each engine should have a sleeve fitted to its exhaust, and led to the

carbureter of the other engine, in case any trouble was experienced in starting either of the engines (in cold weather), especially if fitted with the low tension magneto.

"The circulating pump would have to be made much bigger, with a bigger flow than in the ordinary case, as practically little or no cool air would get to the motor, although the engines ought not to suffer from overheating at any time, as they would get a continual flow of cool sea water through them. A drain cock would have to be fitted below the gasoline tank, and the gasoline drawn off after using the engine, otherwise it would get stale and useless. It would be advisable, I think, to have the gasoline fed under pressure from the exhaust, so as to allow the placing of the gasoline tank below the center of gravity in the boat. The tanks would have to be constructed on a large scale, as it would in all probability be impossible to replenish them in a heavy sea without risk of getting salt water into the tanks (and from there into the carbureter) or upsetting the gasoline.

"I should strongly advise that the lubrication of the various working parts be done by grease, when possible (in small grease cups), the grease being kept under pressure of small springs, instead of oil, which necessitates the additional fitting of various pipes, etc., and the continual watching of the sight feed, and regulating the drops—which at night is an almost impossible job. Kerosene 'wash-outs' for the engine should in all cases be used to prevent 'gumming' of the piston rings, and to facilitate the starting of the engines, especially if the low tension magneto is used.

"A very much larger clutch or flywheel would have to be fitted than in the case of the motor car engine, which has the wheels to help the engine. In conclusion, I should like to remind all drivers and owners of motor-propelled boats that the engine requires more lubrication than is the case with the motor car, as it is ever working up hill. The water acts as a brake on the blades of the propeller, in the opposite direction to the wheels of a motor car."

In this connection it is interesting to note that an American made engine was used in the tests referred to in our December issue as having been made by the Royal National Lifeboat Institution. The boat used was an old one, 38 feet long, 8 feet beam, was pulled by twelve oars double-banked, and was of the usual self-righting type, rigged

with jib, forelug and mizzen. At the shipyard some of the air cases under the deck amidships were withdrawn, and a strong mahogany case measuring 4 feet long by 3 feet wide, and as high as the gunwales, lined with sheet copper so as to be water tight, with a closely-fitting lid easily removable if necessary, was fitted in their place. In this case was placed a 10 H. P. two-cylinder motor built by the Fay & Bowen Engine Co., Geneva, N. Y.

The gasoline is carried in a metal tank stored away inside the forward end box, where it is safe from any possibility of accidental damage. Sufficient oil fuel is carried in this reservoir for a ten hours' run.

Tests which were made showed that the boat could be driven fairly well against a sea by the aid of the engine alone; that while working in conjunction with the sails the true efficacy of the motor as an auxiliary power was realized, and the boat could be worked to windward in a manner that was hitherto impossible. It was also observed that neither the heeling effect of the sails, nor the pitching and rolling in a seaway, interfered in any way with the proper working or starting of the motor, and it ran evenly and regularly throughout, thereby showing that the vaporizer successfully accommodated itself to the varying positions of the boat.

NATIONAL MOTOR BOAT AND SPORTSMAN'S SHOW.

The eleventh National Motor Boat and Sportsman's Show, held in New York February 21 to March 8, brought together a good showing of that specialized form of gas engine—the marine gasoline motor. From a motor-driven canoe to the 35-foot 80 H. P. launch, there were all kinds and sorts of motors. They came from all sections of the country, too, and, while the East is often of the opinion that the West can not build anything in the way of a marine engine that is worth looking at, yet the Western productions made some very strong and favorable impressions.

Among the Western builders was the Clifton Motor Works, of Cincinnati, O., who showed 8, 14 and 28 H. P. engines. All these have mechanically operated valves and are four-cycle engines. They have two and four cylinders. The piston may be withdrawn from the side of the motor. The oil for lubricating is placed in the engine base and tends to go to the rear compartment. A trough catches the spray from the valve lifts and deposits it in the forward compartment. This company is arranging to build much larger motors than their present limit of 32 H. P.

The Brown-Cochrane Company, Lorain, Ohio, displayed two and four-cycle Lacy engines from 3 to 20 H. P. In order to meet the varying conditions, horizontal and otherwise, that a carbureter might assume in a boat, on the vaporizer is placed an air dome to regulate the flow

of the gasoline and prevent flooding of the vaporizer, and insure a constant and equitable flow to the cylinders. With this combination of the air globe on the vaporizer and a special commutator the engine is controlled as readily as with a governor, and racing is prevented. Water jacketed valves are placed in the cylinder head.

The exhibit of the Smalley Motor Co., Bay City, Mich., consisting of engines ranging from 2 H. P. single cylinder to 20 H. P. three cylinders. Either make-and-break or jump spark ignition is furnished.

The Lamb Boat and Engine Company, of Clinton, Ia., showed engines from 1½ to 36 H. P., from one to four cylinders, all four-cycle. Their engines were all finished in aluminum and highly polished brass, making an attractive display.

A 4 H. P. and a 5 H. P. single cylinder and 10 H. P. double cylinder engine constituted the exhibit of the Spaulding Gas Engine Works, St. Joseph, Mich. A pump forced oil to the crank shaft bearings. The igniter is placed on the side of the engine. Around the stationary electrode is spun a platinum wire, while at right angles on the movable electrode is spun another. In turning the stationary electrode by a hand screw the point of ignition or contact is instantly renewed.

A two-cylinder, two-cycle, 6 H. P. engine was shown by the Lackawanna Valveless Motor Co., of Buffalo, N. Y.; also, a 12 H. P. two-cylinder and a 16

H. P. three-cylinder. The engine is wired to a ground on the fly wheel, operated by a governor. When the engine is reversed by throwing over the lever to the end of the commutator the ground is thrown off the spark, the engine slowing down to about 50 r.p.m. The governor is released, throwing in the ground circuit, thus producing a back explosion, which reverses the engine.

Palmer Bros., Cos Cob, Conn., showed a new two-cycle, two-cylinder engine, with spark ignition; also, a 10 H. P. four-cycle engine and other sizes of their regular line.

An engine without a connecting rod was shown by the Isham Company, of Norwich, Conn. The lower part of the piston has a slotted crosshead, the crank working in a sliding bushing, the right-angled crank and crank shaft being one piece. The ignition is by make and break. It consists of but two pieces. The piston lift actuates the crank arms, opening and closing the circuit, making the spark.

Both two and four-cycle engines were shown by the Hubbard Motor Co., Middletown, Conn. These ranged from 1½ to 25 H. P. in size, the largest being a four-cylinder, four-cycle engine, weighing about 500 pounds and run at a speed of from 600 to 800 r.p.m.

Kerosene oil engines were shown by the International Power Vehicle Co., Stamford, Conn. From 1½ to 20 H. P. motors are built by this company. The oil enters the cylinder through a valve and passes through a metal gauge which atomizes it.

The kerosene oil used in the engine itself comes under slight compressed air pressure from a tank in the bow. The motor is started by means of a kerosene torch, the air pressure for which is fed from the large oil supply tank. The oil for the torch is supplied by an auxiliary tank. A steel tube, open on one end, is screwed into the cylinder head. This tube is 3 inches long by ¾ inch in diameter. The heating torch takes about two minutes to heat this tube to a cherry red heat. After running the motor about five minutes from this small tube the heating torch is extinguished. Cast integral with the head is a perfectly straight dome, about six inches high, in which an adjustable ignition plug is

set. When the plug is at the bottom of the dome and flush with the head, then ignition is at its most advanced point. Upon threading the plug further up into the dome the ignition is retarded, the result being a two-cycle type of motor burning kerosene with automatic ignition.

The Snecker Motor Co., Stamford, Conn., showed a high speed two-cycle marine engine, rated at 20 H. P., at 900 r.p.m. Sizes down to 2 H. P. were also shown.

A self-contained ignition system used by the Mianus Motor Works, Mianus, Conn., is so arranged that the sparking plug can be readily removed and tested, a make and break spark being employed. The adjustments on the plug when set are permanent, the only object of removing being for cleaning or examination. A one-piece spark advancer is used, all the varying positions being obtained by moving a small hand lever, which operates an eccentric cam.

The Fairbanks-Grant Manufacturing Co., Ithaca, N. Y., showed their 1½ H. P. two-cycle engine; with reversible propeller.

August Mietz, of New York, also displayed kerosene engines, ranging up to 15 H. P. in size. A lamp is used for heating the head for starting.

The Eagle Bicycle Manufacturing Co., Torrington, Conn., showed several of their models which run from 1 to 25 H. P., in single and multi-cylinder types. An 18-foot canoe, with a 2 H. P. motor, was also exhibited by them.

E. H. Godshalk & Co., Philadelphia, included in their exhibit the Nada, which made a good record last season. The 70 H. P., eight-cylinder motor, recently described in these columns was also shown. Its total weight is but about 680 pounds.

The Trebert Auto and Marine Motor Co., Rochester, N. Y., showed a four-cylinder, four-cycle engine, with mechanically operated valves. An "automatic" carbureter is used.

Walrath stationary engines especially for electric lighting were shown by the Mackay Engineering Co., of New York.

John V. Rice, Jr., & Co., of Trenton, N. J., showed a 1½ H. P., single-cylinder engine of two-cycle type, which was rated at 650 r.p.m., but which ran at a

speed of 3,200 r.p.m. The weight is but 80 pounds.

James Craig, Jr., of New York, exhibited three engines, from 14 H. P. up, one being an eight-cylinder engine.

Chas. A. Carlson, of Brooklyn, N. Y., showed a four-cycle, 30 H. P. engine, which has the advantage of accessibility of parts by the removal of a plate on top of the motor.

E. Louvet & Son, Woodhaven, L. I., showed $1\frac{1}{2}$ to 8 H. P. engines. In the three-cylinder engine of the three-part type, the exhaust and inlet are in one.

Backus stationary engines were shown by W. H. Jeffers, of New York.

Among the accessory exhibits was that of C. L. Altemus & Co., Philadelphia, Pa., who are distributing agents for the Grant-Ferris engines. The Altemus products, in the way of circuit breakers and timers, were well displayed.

The Richardson Engineering Co., of Hartford, Conn., who are making a specialty of gas engine electric light plants, showed a representation of a cabin lighted by one of their plants.

Charles E. Miller, of New York, had a complete exhibit of motors and accessories useful to the motor boat user.

The Remy Electric Co., Anderson, Ind., showed their line of magnetos for ignition use.

The Gas Engine Whistle Co. showed their device for signaling, utilizing the spent gas from the engine. A minute fraction of exploded gas is taken from the engine and stored in an aluminum tank. The hose for the whistle is attached to this tank. A simple touch of the foot or hand blows a good, sharp blast upon a real $1\frac{1}{2}$ -inch chime whistle. Connection to the engine is made by attaching to the compression vent or cylinder head a $\frac{1}{8}$ -inch pipe, with valve and radiator for cooling the spent gas, which spent gas is then conducted to the tank, to which is attached the whistle or horn.

A complete line of "Apple" ignition devices was shown by the Dayton Electrical Manufacturing Co., 139 Beaver Building, Dayton, O.

Edison primary ignition batteries were shown by the Edison Manufacturing Co.

DEVELOPMENT OF THE GAS ENGINE.

One of the most important as well as interesting problems confronting the engineer to-day is the development of the gas engine, especially types of large size for power station work. The economy of gas and other internal combustion engines over the steam engine has long been appreciated; but, until within the last four or five years, little was done with gas engines of large size, owing to the difficulty of regulation and other troubles which were considered inherent in this type of prime mover.

A series of tests were made recently upon a gas engine and a steam engine in an electric lighting station, the two engines being of the same capacity and operating under exactly similar conditions. The economy of the gas engine in this case was very marked, being 45 per cent greater than that of the steam engine.

Among the advantages of the gas engine are its small coal consumption, higher efficiency at small loads, the opportunity for storing the gas when the engine is shut down, thus avoiding all thermal losses,

and the use of the cooling water for the cylinder for heating.

A somewhat unique gas engine plant is at present being installed at Jamestown, N. Y., the power for which will be supplied by natural gas. The initial equipment consists of two 500 H. P. engines of the horizontal single-crank, double-acting type. This company began experimenting with the use of gas engines three years ago, and they have operated with sufficient success to warrant the exclusive adoption of gas engines for the entire plant. Several of the largest engine builders in this country are now producing gas engines which are guaranteed to regulate closely enough for the operation of alternating current machines running in parallel, and this is probably the most exacting service, as far as regulation is concerned, which any engine is called upon to perform. As an economy of 50 per cent is practicable by using the gas directly in the engine instead of under the boilers, the field of the gas engine is a very promising one.—*The Technical World.*

A GAS PRESSURE ANTI-FLUCTUATOR.

Gas engine users are often annoyed by the fluctuation in the gas pressure which occurs when the engine takes in a charge of gas. Near-by lights and machines supplied by gas will often suffer in consequence of this fluctuation. Not only this; if the engine takes gas direct from the supply pipe it is usually the case that the pipe is not large enough to give the engine a full charge of gas.

To overcome this the customary gas bag or gasometer is used. The former is merely a rubber receptacle into which gas may collect until the engine needs a charge, when the gas is taken from the gas bag. The gasometer is a large can partly filled with water. A pipe extends through the base and opens into the can above the water surface. Inverted into the water is another can, or top, which floats on the water and is connected by an arm to a valve which is placed in the gas supply pipe leading to the pipe in the gasometer. As the top of the gasometer is lowered the arm from the top opens the supply pipe valve. This allows the gas to enter the gasometer float and thereby raises the float itself. When the engine sucks gas for a charge from the gasometer the float falls and opens the valve in the supply pipe. The objection

to this type of gasometer is that the inlet valve in the supply pipe does not always close by the time the engine takes gas. If the gasometer is not sufficiently large this means that the engine still takes gas from the supply pipe.

In one case a large engine was supplied with gas from a three-inch main. The result was that people in the neighborhood could not burn gas lights when the engine was running. Just as soon as the engine was started it caused such a fluctuation in the pressure that the lights even across the street would go out. Unless the pressure of gas in the gas bag or gasometer is the same each time the engine takes a charge the quantity of gas taken in by the engine will vary a little. This means that the engine will not always get just the same size charge, and therefore the consumption of fuel varies, whereas it should not do so. When city gas, at from 50 cents up per thousand feet, is used it is necessary to keep the fuel consumption down as low as possible, and therefore a device which will not only reduce the fuel consumption, but will also obviate the annoyance due to fluctuation in pressure, is a very desirable one, even though in first cost it may be a little higher than the usual devices employed.

The anti-fluctuator shown in the accompanying illustrations is a device employed for this purpose. The general arrangement of the device when connected to the engine is shown in the half-tone, while the sectional view shows how the device operates.

The service pipe connects with the nipple 10 at one side of the cylindrical shell or casing of the improved anti-fluctuating device, the shell being made from thin sheet metal in open-topped or cup-like form and having the nipple 10, formed of a metal casting, secured upon its side, so that gas may be supplied to the interior chamber or hollow 9 of the casing. Inside of the casing the nipple 10 is provided with a short extension 11, extended at a slight upward angle and adapted to be closed by a flap-valve 12, hinged at its edge to the upper part of said extension and adapted to fall



The Broderick
Anti-Fluctuator.

gravitation in position as seen in full lines to close the passage through extension 11, so that backward flow of gas from casing 8 to the service pipe may not take place. At its under side the casing is also provided with a casting or reinforce 13, secured to it and provided with a nipple having connection with the interior chamber and also having connection, as seen at 14, with a pipe 15, leading to the intake of the gas engine, to which gas is thereby supplied for operation from the anti-fluctuating device; 16 indicates a leather or other flexible diaphragm extended across the open top of the casing of the anti-fluctuating device 9 and provided with a loose central part, which is permitted to play upward and downward from the position seen in full lines to that shown in dotted lines at X. The edge portions of the diaphragm or flexible top 16 of the casing may be lapped upon the outer side of the shell, as seen at 21, and, cemented, may be held to the shell to produce a gas-tight joint in any other desirable manner. Normally the loose or sagging central portion of the flexible diaphragm is depressed by means of weights 17 and 18; but when gas is admitted to chamber 9, beneath the diaphragm, the pressure of the gas will be exerted to lift the diaphragm to the position indicated in dotted lines at X. The central part of the diaphragm is clamped between the weights 17 and 18, which serve for the convenient attachment of a stem or guide rod 20, extended upward above the casing and serving to guide the upward and downward movements of the diaphragm, as will be hereinafter explained. 24 is a protective cap or hood arranged above the casing 8 and designed to protect and corner the diaphragm 16 during its movement. This cap has a flange 27 resting on the support 26 to maintain its position, and at its apex the conical cap or hood affords a bearing, as seen at 28, in which slides the upper end of the stem or guide rod 20. By this arrangement the diaphragm is caused to move up and down evenly and without binding, and its flexibility is maintained for a longer time without the liability of cracking or deterioration due to the weight upon its central part.

In the operation of the improved anti-fluctuating device it is evident that as

the gas engine draws gas from the pipe such gas will be withdrawn from the chamber 9 of the casing 8, which will be of sufficient capacity to permit this, and when the gas is so withdrawn from the chamber the flexible diaphragm 16 will sag or fall to the position shown in full lines under the influence of the weights 17 and 18, as well as of the suction of the engine, and when a charge has been drawn from said chamber the gas from pipe 3 will again flow therein, lifting valve 12, as indicated in dotted lines, and raising the flexible diaphragm 16 against its weights to the uplifted position, shown in dotted lines at X, the stem 20 playing upward in its bearing 28 to the position shown at X during this movement of the diaphragm.

By this structure it will be seen that

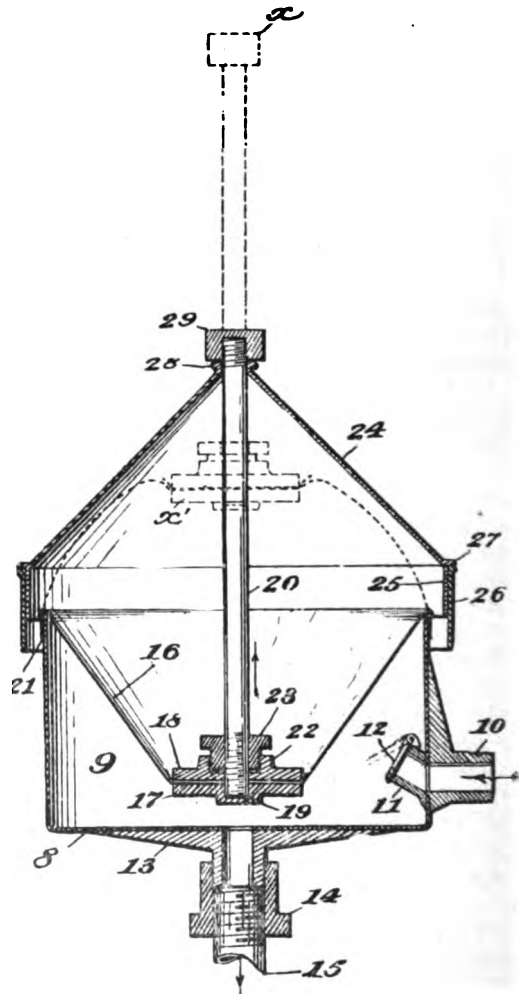

the flexible top wall or diaphragm 16 fully compensates for the withdrawal of gas from the chamber 9 and prevents entirely those fluctuations and variations in pressure which are ordinarily exerted in the service pipes during the operation of gas engines and which tend to cause fluttering and extinguishing of the flame at burners connected with the same pipes and in some cases interfere with working of the meters and even cause fluctuation in the mains. It will also be seen that this construction avoids the employment of a large meter, such as is sometimes provided for use in connection with service pipes from which gas engines are supplied, and the structure is so simple as to be very inexpensive and durable and is not liable to be dragged or broken.

The removable cover or cap 24 may be taken off by unscrewing the enlargement 29 of the stem 20, so that the entire upper surface of the diaphragm 16 may be exposed for inspection and repair. The

cap or hood 24 also effectually protects the diaphragm, and at the same time the vents provided between the shell 8 and the support 26 permit free operation of the diaphragm by affording ready escape of air on the upstroke thereof.

These anti-fluctuators, which are made by the Broderick Anti-Fluctuator Co., 332 West Third Street, Cincinnati, O., are built in sizes varying from the smallest engine up to 60 H. P. and even larger, and may be used on any kind of gas and at any pressure of gas in the mains. There are quite a number of them operating on engines in Cincinnati, and they have been very successful in overcoming fluctuations and the attending disadvantages which were formerly experienced by many engine users there. The fact that the gas is always under pressure allows the engine to secure the same charge at all times, while the automatic valve at the inlet shuts off communication from the gas main.

OPERATING LARGE GAS ENGINES IN COLD WEATHER.

By G. W. KLOCKENTGER.

To operate successfully a large gas engine in extreme cold weather and under conditions common to outdoor machines is quite a different proposition than in a nice, warm room, by a good fire. To start with, the machine on a bitter cold day is the first grievance against the gas engine, which is very easy if you go about it in the right way.

Your engine will be frosty, and those starting by hand will find it very hard to handle their engine in this operation; but use a gasoline torch of some kind and warm up the inside of the cylinder from the open end, and if your engine has a tube igniter light it. After this is done apply a fire of some kind to the air-mixing pipe and get it very warm, turn on the oil, and if your engine is of the hit-and-miss governor type hook up the governing valve with the cam below the relief so you can move your engine forward two revolutions before compression begins. This will give you a chance to get the large wheels in motion, and starting is much easier. After you have one or two impulses, if you choose, turn out your tube and turn on the electric ig-

nitator, the latter being much preferred for outdoor work.

After your engine has run for a minute or two, turn on the water. Don't wait for fifteen or twenty minutes, as getting the cylinder very hot does your engine no good. Be sure to use a good grade of high fire test oil, and use it with judgment on the cylinder; 9 to 12 drops per minute is better than 20 or 30, as too much is injurious to the cylinder ring action, and to your igniter, while too little oil is much worse. For engines using oil of any kind to operate with you will find it will save you lots of cold fingers if you will put a nipple about six inches long with a drain cock in the lowest point in your supply pipes, as this arrangement will catch most of the water and dirt, and by drawing this once in a while during the day you will find it will save you lots of freeze-ups.

It is also good practice to have two or three forms of ignition, that, should one battery or magneto get slightly out of order, you will not have to stop and repair it, but turn the switch on the oth-

and go ahead. You can then make the necessary repairs by the fire. Always be very careful to strain the oil carefully before putting it in the tanks, for dirt, etc., that is bound to accumulate in outdoor use will give you all sorts of trouble.

Keep your engine as clean as possible, more especially the governor. If you neglect this the grease will get cold and your governor will be sluggish and refuse to act. See to it that your engine is in shape every morning before you start, and don't start until it is, and you will have little or no trouble. Don't blame the engine for your own carelessness or ignorance, for I have operated an engine successfully at 20 deg. below zero, and even colder, but use a little judgment, and bear in mind that it is very important to see to it that your engine is always kept properly adjusted and the water removed from the cylinder as soon as the engine stops, for while the engine is hot the water being dried from the cyl-

inder will allow the cooling space to dry out thoroughly.

Gas engines are much more easily operated in cold weather than other engines. The worst obstacle in the way of starting a gas engine is that gasoline or kerosene will not mix readily when your engine is cold, but by getting the mixing pipe warm to start on this is overcome. These few hints will suffice, and if you will follow them closely you will have little trouble. But always remember this: The engine has run—it will again. Don't stand and pull on the wheels for a half hour to start. If it doesn't go readily, simply remove the cause—then it will. More engines are worn out by carelessness or ignorance among the average operators than are worn out doing their duty. Don't let this be your case. If you do not understand your machine, familiarize yourself with its action and its parts, for, without a practical knowledge of this engine it will be a failure.

ANOTHER AMERICAN SUCTION GAS PRODUCER.

The rapid development of internal combustion engines in the last few years has placed them upon the same plane as steam engines, insofar as closeness of regulation, durability and reliability of service is concerned.

This fact and the relatively high economy of a long time known to be obtainable from gas engines has been instrumental in directing the attention of engineers and gas engine manufacturers to some cheap source of gas or some form of gas plant at once economical of operation, compact and reliable. The result of this effort has been the adoption of producer gas plants of two types, namely, the pressure producer gas plant and the suction producer gas plant, each possessing merits to itself and adapted to a particular field of service.

For power purposes alone the suction producer plant has been found to possess more advantages than the pressure type, particularly for the reason that it is automatic in operation and generates just the amount of gas required by the engine, whether the load be 25 per cent or 100 per cent. Such a plant also eliminates the

necessity for a gas holder, which is expensive both in first cost and in space requirements.

Among the first large builders of gas engines to make a study of the producer gas problem were Fairbanks, Morse & Co., whose researches have extended over a period of three years past, and whose investigations included personal investigation of French, German and English practice, as well as direct observation from an elaborate experimental department of their own.

The result of these investigations and experiments has been the adoption of the suction type of producer, which is illustrated by half-tone and line-drawing herewith. "A" is the generator, utilizing either anthracite coal, charcoal or coke for fuel, which is charged through a hopper, of ample capacity, located on top of the generator and so designed as to permit of charging without admitting an undesirable amount of air to the apparatus. Pokeholes of special design are so located as to permit of continuous and successful operation of the producer, even when inferior grades of fuel are

made use of. Cleaning doors of ample dimensions in the generator and in the ashpit facilitate the operation of the plant.

As is usual with the suction type of producer, the air for supporting combustion is drawn from across the surface of a vaporizer and is saturated with steam at atmospheric pressure before being carried to the combustion chamber. This intake air passes through a connection fitted with swing check valve for the purpose of preventing the escape of gas to the engine room, should there be any internal pressure at any time.

The vaporizer "B," made use of, is provided with gas passages of unusual area, with the idea in view of eliminating the

effective scrubbing and cooling, with which idea in view the scrubber "C" has been made of unusual height and of liberal area. This part of the plant is made of sheet steel, carefully riveted, gas-tight, and provided with cast-iron grates, above which the scrubber is filled to the top with clean foundry coke.

A water spray valve is located in the scrubber head, and is of a design which permits carrying full water pressure at the nozzle, thereby making more effective the spray for scrubbing and cooling purposes and materially lessening the volume of water required for this purpose.

After leaving the scrubber the gas is carried to a gas receiver of sufficient

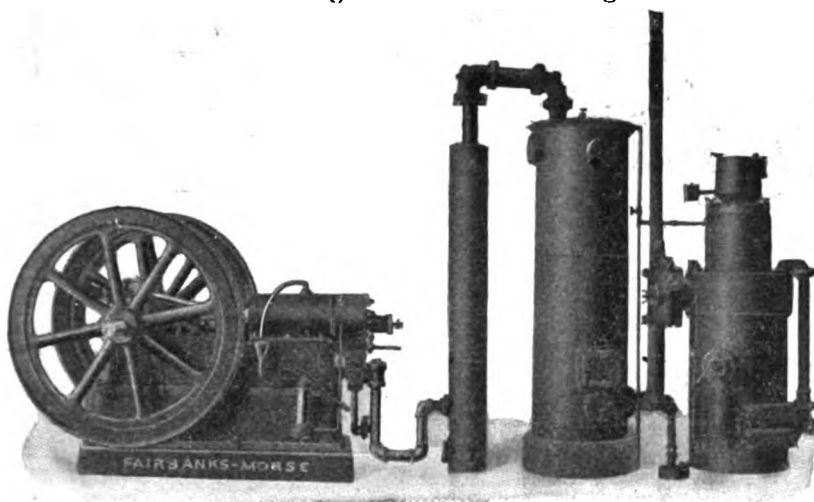

The Fairbanks-Morse Suction Gas Producer.

difficulty of clogging, which has been experienced with vaporizers of the vertical tubular boiler type.

Upon leaving the vaporizer the gas is carried through a combined three-way and relief valve of novel and effective construction. In one position of the valve lever the gas is directed to the atmosphere, the valve being in this position when the fire is banked, and when the producer is being fired up preparatory to starting. In another position of the valve lever the gas is cut off from the atmosphere and is directed through the scrubber to the engine. The construction of the valve, however, is such that any internal pressure on the system will be automatically relieved to the atmosphere.

Special attention has been given to capacity to insure at all times a full cylinder charge of gas without appreciably lowering the pressure in the gas connections and without producing an undesirable pulsation in the draught of the fire. For horizontal engines this gas receiver is of the type shown by the illustration, and reaches down to the floor level, at which point a try-cock for gas is provided; also handhole to be used for inspecting and cleaning.

Gas for power is taken from this receiver at a point approximately in line with the cylinder, the effect being to produce a pocket into which any moisture and by-products present in the gas are deposited.

When fuels are used which require more cleaning than can be secured in th-

scrubber, a purifier of box construction is inserted in the system between the scrubber and gas receiver.

It will be noted from the illustration that all principal piping connections are flanged, with elbows fitted with hand hole plates permitting of inspecting and cleaning all passages in both directions. All principal water connections are likewise provided with either tee or cross fittings for the purpose of inspecting and cleaning.

All parts of the complete installation from the generator to and including the

engine are manufactured by the company, insuring a plant of harmonious proportions and one which is guaranteed in its entirety.

The manufacturers report unexpected success in the introduction of their gas producer plants and engines, which are rapidly being installed for all classes of power service, comprehending flouring mills, machinery and general manufacturing establishments, municipal electric light and power plants, private electric light and power plants, isolated power plants for city and state institutions, etc.

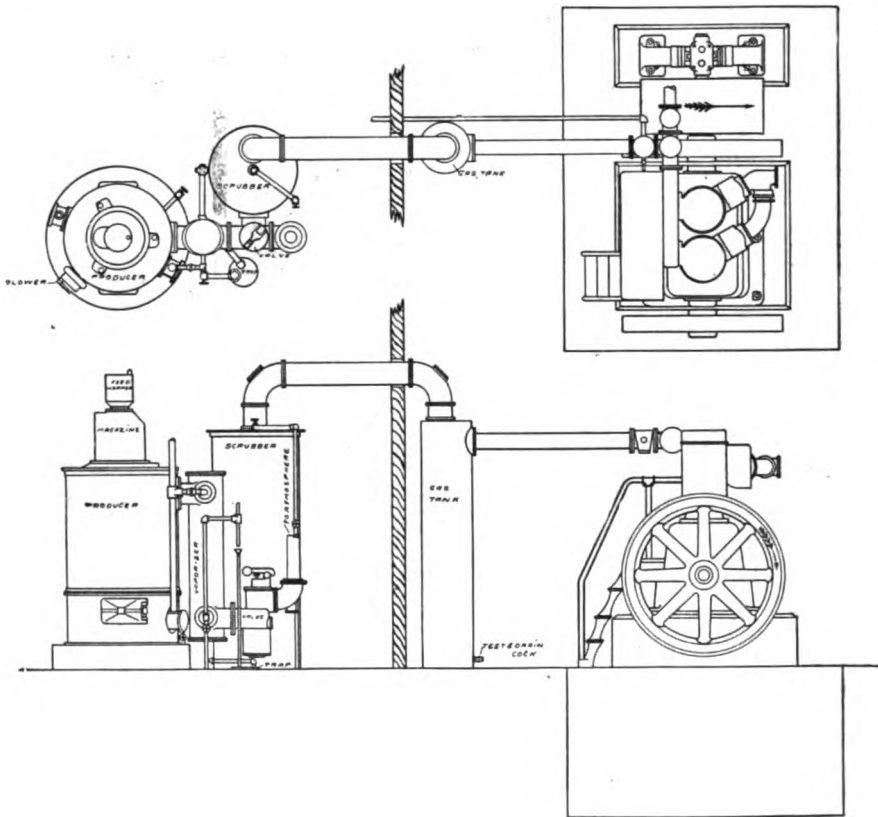

LEMARE'S SUCTION GAS PRODUCER.

According to the French specification of M. Lemare's patent, as abstracted in the *Journal of the Society of Chemical Industry*, the fuel in the producer rests on a solid hearth of refractory material, which can be oscillated by means of an external handle, for the purpose of loosening the fuel. A boiler for supplying the steam required by the producer is placed in the

path of the hot gases between the producer and the scrubber. The latter is built up of superposed interchangeable short cylindrical sections, provided with horizontal plates having devices for breaking up the current of gas as it ascends through the water flowing down over the plates. At the top of the scrubber the washed gas enters a chamber fitted with a partition.

RECENT BOOKS ON GAS ENGINES AND AUTOMOBILES.

About a year and a half ago we published a very complete catalogue of books which had been published up to that time on gas engine and allied subjects. This catalogue may be had on application.

Last June we published in this magazine a list of additions which had appeared since our catalogue was issued. We are again giving a list of new works, including those given last June, so that those of our readers who have the book catalogue may merely add the accompanying list. A few of these works are yet in press, but will be out very soon. Any of them may be secured by remitting the amount to The Gas Engine Publishing Co.'s book department:

Bale, M. P. *Gas and Oil Engine Management: being notes on selection, construction and management.* 8vo. Cloth. Illustrated. 110 pp. London, 1903. \$1.50.

Booth, Wm. H. *Liquid Fuel and Its Combustion.* 1903. 4to. 411 pp. \$8.00.

Bottone, S. R. *Ignition Devices for Gas and Petrol Engines.* London. \$1.00.

Davis, Wm. M. *Friction and Lubrication.* 225 pp. 5½x8. Cloth. Illustrated. \$2.00.

DeHolder-Stone, G. *The Automobile Industry.* With numerous figures and diagrams. 12mo. Cloth. 223 pp. London. \$1.25.

Dry Batteries, How to Make and Use Them, by dry battery expert. 59 pp. Paper. 25c.

Haenssger, Oswald H. *Suction Gas* Explains the construction and operation of suction gas producer and producer gas engines. Illustrated. Cloth. 90 pp. \$1.00.

Hall, H. R. *Governors and Governor Mechanism.* 1903. 16mo. 119 pp. Illustrated. \$1.00.

Hutton, F. R. *The Gas Engine: A treatise on the internal-combustion engine.* 8vo. XVIII-|-483 pp. Illustrated. Cloth. \$5.00.

Koenig, H. Lee, and G. W. Rice. *Current Practice in Gas Engine Design,* being No. 121 of Van Nostrand's science series.

Marchis, L. *Les Moteurs a Essence Pour Automobiles.* A French work by

the Professor of Physics at the University of Bordeaux, being based on lectures given by the author. 1904. 8vo. 470 pp. Illustrated. \$4.50.

Mathot, R. E. *Gas Engines and Producer Gas Plants.* The principles of gas engines and producer design, the selection and installation of the engine, the care and possibilities of these plants are considered. There is also a chapter on volatile hydrocarbon and oil engines. 320 pp. Illustrated. \$2.50.

Mecredy, R. J. *The Motor Book.* 16 mo. Pocket size. Leather, \$1.20. Cloth, \$1.00.

Mecredy, R. J. *The Dictionary of Motoring,* being both a dictionary and an encyclopedia of automobile terms. \$1.25.

O'Gorman, M. *Motor Pocket Book,* with marginal reference notes, tables, diagrams and engravings. 12mo. Leather. Illustrated. 287 pp. 1904. \$3.00.

Plauck, Dr. Max. *Treatise of Thermodynamics,* a translation of the author's work in German, presenting the entire field of thermodynamics. 8vo. 270 pp. \$3.00.

Roberts, E. W. *The Automobile Pocketbook.* A companion piece, in style of binding, to the *Gas Engine Handbook,* by the same author. Covers thoroughly the subjects of gasoline automobile construction, operation and care. 325 pp. 52 illustrations. 3½x5¼. Flexible leather. \$1.50.

Sexton, A. H. *Producer Gas.* A sketch of the properties, manufacture and uses of gasoline fuel. With figures and diagrams. 8vo. Cloth. 220 pp. Manchester, 1904. \$4.00.

Sorel, E. *Carburation et Combustion dans les Moteurs a Alcool.* The conditions under which alcohol may be successfully used in internal combustion engines. 8vo. 280 pp. Paris, 1904. \$2.50.

Stodola, A. *Steam Turbines,* with an appendix on Gas Turbines and the Future of Heat Engines. Translated from German by Dr. L. C. Loewenstein. 241 cuts, 3 lithograph folding tables. 8vo. Cloth. 416 pp. 1905. \$4.50.

Swinburn, Prof. James. *Entropy, or Thermodynamics from an Engineer's*

Standpoint. London. Cloth. 150 pp. 7x5. \$1.15.

Tookey, W. A. Gas Producers for Power Purposes. 137 pp. London. \$1.00.

Tookey, W. A. Oil Engines: Their Selection, Erection and Correction. London, 1904. 50c.

Tookey, W. A. Gas Engines: Their Advantages, Action and Application. 16mo. Board. 107 pp. London, 1904. 50c.

Wender, N. Die Verwertung des Spiritus fuer Technische Zwecke. 8vo. Describes the methods of utilizing alcohol, methods of producing it, alcohol illumination and cooking, and alcohol motors. \$1.50.

White, T. H. Petrol Motors and Motor

Cars. A handbook for engineers, draughtsmen and designers, with figures, diagrams and plates. Cloth. London, 1904. \$1.50.

Witz, Aime. Moteurs a Gas et a Petrole. This is in French and is in two volumes. It is a very complete work and covers internal combustion engines, classes of engines, the theoretical consideration of thermal machines, thermodynamic laws, thermal cycles, combustible gases, theory of gas engines, entropy diagram, tests. Paris, 1903. 497 pp. 7½x11. Paper. Illustrated. \$5.75.

Young, A. B. F. The complete motorist. An account of the evolution and construction of the modern motor car. Cloth. Illustrated. 338 pp. 1904. \$3.50.

THREATENED SHORTAGE OF GASOLINE.

The Standard Oil Company is sounding a note of warning to makers, sellers and users of gasoline engines, stoves, launches and automobiles. The warning is to the effect that the phenomenal increase in the consumption of gasoline for heating, lighting and power purposes will inevitably lead to a shortage and higher prices. Only a few years ago gasoline was an almost unsalable by-product of petroleum, and in line with its policy of creating a demand for slow selling products that company fostered and stimulated the manufacture and sale of gasoline stoves. Then came the gasoline engine, and on its heels the automobile, followed by extensive systems of domestic and municipal lighting by gasoline. Three or four years ago the Standard Oil Company, reading the future in the conditions already existing, began to warn the public that the supply of gasoline would soon be inadequate to the demand. But this warning has largely been dismissed by the trade and the public at large as only another "Standard Oil scheme." Fortunately, the supply of petroleum has recently been greatly increased, or the threatened shortage might have become a fact.

In refining crude petroleum only from 8 to 1 per cent of naphthas is produced, depending on the gravity of the oil. From these naphthas only about 50 per cent of gasoline can be obtained, so that the maximum production of gasoline is limited to

an average 5 per cent of the crude oil refined. But the actual production of gasoline is limited in other ways. As soon as the refiners discover that they are glutting the market on the principal petroleum products—kerosene, paraffine and lubricating oils—they cease refining.

The immediate remedy for the excessive demand for gasoline is likely to be sharp advances in price until the price becomes prohibitive for ordinary purposes, the high prices being maintained until the production can catch up with the demand and an equilibrium be restored. Another remedy which is being strongly exploited by the Standard Oil Company is the manufacture and sale of stoves that burn kerosene instead of gasoline. The manufacture of oil burning engines, in which the oil is vaporized in hot tubes and the resulting gas exploded similar to the gasoline engine, is also receiving the encouragement of that company. Efforts are also being made to perfect oil burning automobile engines. Makers of gasoline lighting systems for homes, stores and towns are charged with working the greatest damage in proportion to the success of their operations, because every system they install reduces the consumption of the too plentiful kerosene and substitutes for it a product that can not be made without producing six or seven times its volume in the kerosene which it displaces

—The Iron Age.

A N S W E R S T O I N Q U I R I E S
--

It is our purpose to answer in this column inquiries of general interest which relate to the gas engine or its accessories. The questions will be answered in these columns only, and we reserve the privilege of refusing to answer any question which is not, in our judgment, of interest to the subscribers of THE GAS ENGINE.

All matter intended for this department should be addressed to The Editor of THE GAS ENGINE, Blymyer Building, Cincinnati, Ohio. The name and address of the sender must accompany the inquiry in all cases as evidence of good faith. The initials only of the sender will be published, together with the postoffice and state.

Write on one side of the paper only, and make all sketches and drawings on a separate sheet. Mark each sheet with the name and the address of the sender.

Will you please give me a little information as regards ports. Which of the ports are correct, as shown in the enclosed sketch? Should the inlet open when the exhaust is open $\frac{5}{8}$ inch, as shown in Figure 1, or should the exhaust port open 15-16 inch before the inlet opens as in Figure 2? How long should these ports be for an engine to run 900 r.p.m., stroke of 4 in., bore $4\frac{5}{8}$ in.? I expect this engine to run at 900 under load of 14 in. fluke wheel.

L. E. E.,
Dixon, Ill.

It is not worth while to publish the sketches, as we believe both to be radically wrong. The inlet port for this engine should $\frac{1}{2}$ in. in the direction of the piston stroke and the exhaust port $\frac{3}{4}$ in. in the direction of the piston stroke. Both ports should be $2\frac{3}{8}$ in. long and no cross ribs are necessary. The bottom edge of both ports should be even with the top of the piston when the latter is at the bottom of its stroke.

In this case the drop will be $\frac{1}{4}$ in.; that is the distance that the exhaust port is open before the inlet begins to open. If the inquirer will make a third port for the intake into the crank-case $\frac{7}{8}$ in. by 1 in. so that the piston closes the crank-case port when it has made $\frac{7}{8}$ in. of its stroke much better results will be obtained at high speeds.

What diameter and what weight fly-

wheel should be used for a $4\frac{1}{4}$ in. bore, 4 in. stroke, two-cycle automobile engine, 800 r. p. m.?

W. G. H.,
West Medway.

We would suggest a flywheel about 16 in. diameter and weighing at least 120 pounds.

(a) What portion should the third port of a two-cycle gas engine be? Size, $3\frac{1}{2} \times 3\frac{1}{2}$ in., running 800 r. p. m.? (b) What length piston should be used?

G. S. V., Jackson, Mich.

(a) We should make the crank-case inlet $\frac{3}{4}$ in. 1 in. and so place it so that when the piston is at the top of its stroke the lower edge of the piston will be even with the top of the port. (b) Make the piston at least $4\frac{1}{4}$ in. long.

I send you a sketch of the way my engine takes its supply of gasoline. I want to do away with the overflow. Can you tell me how to make a mixer that would not be very expensive and that would work without the overflow?

L. C., Delta, O.

The overflow you show in your sketch can be dispensed with if you use a nozzle and float feed chamber such as you will find on almost any type of gasoline automobile vaporizer or by using an ordinary mixing valve. If your engine works hit or miss, which we presume it does, a good gasoline mixing valve would very likely solve the problem. They can be obtained from several of the manufacturers of automobile supplies.

I have a three-cylinder $4\frac{1}{2}$ in. by $4\frac{1}{2}$ in. 12 H. P. engine, 900 r. p. m. The cams for the exhaust are on top of engine and exhaust pipes on side with the intake valves next to the spark, plugs on opposite side of exhaust. It seems to be impossible to get it to run longer than five minutes at a time. Sparks and coil are all right, but am using a King commutator and a Turner carbureter, 1 in. opening. Can you tell me where my trouble lies? This engine is in a boat.

H. G., Chicago, Ill.

It is practically impossible to tell what is the matter with your engine with the

brief description you give. It will probably take a careful examination of the engine by an expert to determine where your trouble lies. It may be that the valves cause it, or it may be improper lubrication, perhaps a weak battery or loose connection, improper adjustment of carbureter or poor circulation of water.

A letter of later date from this same inquirer seems to show better results, and that he was getting too much gasoline evidently from bad adjustment of carbureter. As the carbureter is made in your city we would suggest getting some one from the factory to help you

Will you kindly, in your answers to inquiries, give me the size of the port opening of a three-port, two-cycle $3\frac{1}{4}$ in. by $3\frac{1}{4}$ in. engine running at 1,200 r. p. m.? Will the ports require more than one bar across each to keep the rings from catching in the port edges? (b) I compute the compression space to be $\frac{3}{4}$ in., as proportioned from the closing of the exhaust port as being the actual piston displacement. Is this correct? Will not a 95-pound compression give more power? (c) I am building this engine with inside flywheels, 14 in. in diameter $1\frac{1}{4}$ in. thick. Should it run successfully? (d) At that point in the stroke should the compression relief cock be placed to insure easy turning of the crank and yet preserve enough of the compression to secure the starting of the engine while the cock is open? (e) What should be the size of the hole? (f) Where can I get wire gauze brushes for igniter service? (g) What compensating vaporizers similar in principal to the Rambler are on the market? (h) What size vaporizer should I use on this engine? Will the same size do for a $4\frac{1}{2}$ in. by $4\frac{1}{2}$ in.? (i) Should the water space be deeper for thermosyphon cooling system than where a pump-circulating system is used?

C. E. B., Brighton, N. Y.

(a) Inlet $\frac{3}{8}$ in. by $1\frac{5}{8}$ in., exhaust 9-16 in. by $\frac{5}{8}$ in., crank-case inlet $\frac{5}{8}$ in. by $\frac{7}{8}$ in. No bars will be necessary if the rings are so pinned that the openings will not come opposite the ports. (b) Compression space should be 15-16 in. This will give you 85 pounds compression. More than this will probably cause premature ignition. We do not believe

that the inside flywheel will work successfully in a two-cycle engine, as it will be difficult to get sufficient crank-case compression. (d) Place the compression relief cock at $\frac{1}{2}$ stroke. (e) Make the inlet for a $\frac{1}{8}$ in. pipe tap and use an ordinary relief cock. (f) Probably from some of the manufacturers of ignition dynamos. (g) There are a number of compensating vaporizers on the market. A few of them are the Schebler, the new Kingston, the Daley, the Holley and many others. (h) About 1 in. diameter. A $1\frac{1}{4}$ in. would be necessary for the larger engine. (i) Not necessarily, but the circulating pipes should be about twice the size required for forced circulation.

(a) A three-cylinder marine engine turned 250 r. p. m. with a make and break of spark. It was changed to a jump spark and then turned 20 revolutions faster than had ever been possible with a hammer-break spark. What is the cause? (b) A four-cylinder automobile engine with jump spark turned 800 r. p. m., running on the battery. When the dynamo was switched on there was a marked increase in the speed—about 40 or 50 revolutions. I should judge. All the conditions were the same as with the battery. Will you kindly give an explanation of the above in your next issue?

A. D. D., Portland, Ore.

(a) The only answer to this question seems to us to be that the spark was better located with the jump spark, and hence gave a quicker ignition. Usually there is not such a great deal of difference in the performance of an engine with the different systems, except that the average make and break, as used on stationary engines, will not stand a high speed, although the make and break system, when carefully designed, can be used at as high a speed as a jump spark. (b) In this case the dynamo evidently gave a lower spark and thus increased the speed of ignition. Changing the speed of ignition means that the flame gets a better start and advances more rapidly to the limits of the mixture. It has often been found that with a storage battery and dynamo combined, used on an automobile, the automobile would run faster with a dynamo

DEAN GAS ENGINES.

The Dean-Waterman Co., of Covington, Ky., manufacturing Dean gas and gasoline engines, has recently added to its line a 35 H. P. single cylinder horizontal engine, which is illustrated herewith.

This engine is notable for several features resulting in marked simplicity. It is of the four-cycle type, and all four operations of the cycle are directly controlled by a single side shaft, which is actuated by the crank-shaft through close-fitting spiral gears. At the extreme end of the side shaft is the governor. As the governor weights are thrown out by the revolving shaft they draw back the governor cam until it misses contact with the roller bearing on the gas valve stem which controls the supply of fuel to the engine, thus saving every charge not necessary to keep up the full speed of the engine. The slightest change in speed will bring the governor cam again into

contact so as to admit a charge of gas and air, or gasoline and air, into the mixing chamber.

From this mixing chamber the fuel is sucked into the cylinder, the inlet valve being opened by a cam on the side shaft and then the charge is compressed by the return stroke of the piston. The revolving side shaft has now raised the igniter post to the high point on the igniter cam and caused the stationary and loose electrodes of the igniter to connect—they are separated by the sudden fall of this post from the high point of the cam and a spark is made, igniting the charge. At the end of the resulting power stroke the exhaust valve is opened by the next cam on the side shaft, thus the cylinder is cleared of burnt gas and the cycle is completed.

It will be observed that each operation is effected directly by its particular cam on the side shaft, and these cams are

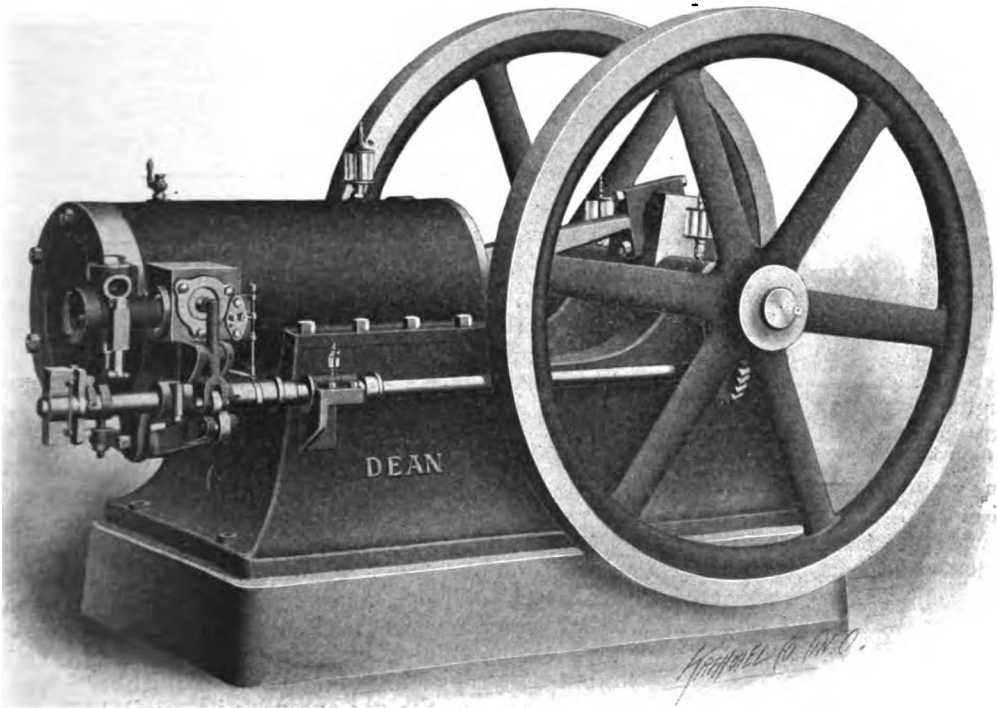

The Dean Gas Engine.

carefully adjusted and securely pinned in the factory so that each operation must occur at the proper time in the cycle of operation. Moreover, all the parts are easily accessible and so definite in their action that their purpose is apparent even to one quite unfamiliar with gas engines.

The company operates its own foundry, thus securing castings of superior quality especially adapted for gas engines.

Both the inlet and exhaust valve boxes are cast on the cylinder, and special attention has been paid in the designing of this engine to make it possible to remove various parts for examination, when desired, without disturbing the balance of the engine. Very accurate adjustment for the connecting rod bearings have been provided, and the main bearings are of phosphor-bronze.

The smaller size of Dean engines having proven successful in the past, their general design has been followed in the 35 H. P. shown herewith. We had the opportunity of seeing the first of the 35 H. P. engines given its initial test, which proved very successful.

The engines operate on either gas or gasoline and may be equipped for both so that a change from one to the other fuel can be made instantly without stop-

ping the engine. Another feature is the ease in starting, for even the largest sizes can be started on compression without any starting apparatus whatsoever, and without the long and laborious turning of the fly wheels necessary in many other designs.

Dean engines are made in various sizes from 2 to 35 H. P. in the single-cylinder type, and in the double-cylinder type to 70 H. P. Each engine is thoroughly tested before shipment and amply protected by the guarantee of the manufacturers. However, the greatest guarantee that can be made for any engine is the satisfaction that its users get from its use.

There are many Dean engines scattered throughout the country giving thoroughly satisfactory service under varying conditions and in all classes of work, for these engines prove their marked economy as well for farm use as for that most exacting service, electric lighting, and many of the engines are in operation among butchers, bakers, printers, woodworkers, machine and blacksmith shops, etc. The company issues, in addition to its well-illustrated catalogue, a booklet giving the names of users in many lines of industry, and testimonials from a large number of its customers.

GAS ENGINES FOR WATER WORKS SERVICE.

Water works officials in many localities are devoting some attention to the consideration of the question whether the substitution of gas or gasoline engines for those operated by steam in water pumping service might not result in a much greater economy by materially reducing coal bills and other expenses incident to the methods now in vogue. The employment of gas and oil engines in connection with the supply of water in Germany has developed to a considerable extent. Ten years ago only the steam engine was considered available for pumping, when a suitable water power could not be found, but today engineers in that country are no longer so restricted, but are able to use gas engines for such work. There are at present in Germany about 100 pumping plants in water works operated by gas or oil engines. In those cities and

towns where it is impracticable to operate the motors with the ordinary lighting gas, they can be run by gasoline and petroleum. The leading advantage of the gas engine is that it needs no boiler or chimney, and thus saves space—an important matter in some places. As regards safety and durability, it is equal to the steam engine, while so far as superintendence is concerned the gas engine has the advantage. One man can look after a number of motors and pumps if arranged in a single room, and his duties are not difficult, consisting, principally, of starting and oiling. A steam plant of moderate size requires an engineer and fireman, and, possibly, a coal handler. Another advantage of the gas engine is its availability for immediate service. The largest pumps can be put in operation in four or five minutes, which is of great importance in case of fire

or extraordinary demands for water. This also warrants the construction of smaller water towers, since the engine supplying them can be run intermittently, as often as desired, without any loss of gas during the time it is not in operation. Steam pumps can only be kept ready for use by maintaining a fire under the boilers all the time, which necessitates a constant expense for fuel and attendance. These considerations also point to the value of a gas engine as a reserve in a steam plant that runs normally at or near its maximum capacity. Pumping by gas engines is also advantageous to a gas plant, as the harder pumping occurs during the daytime, when the demand for gas is otherwise slight, while less water is required during the evening, when more gas is needed for illumination.

From a paper read at a meeting of German gas and water engineers, the following brief references to a few of the pumping plants operated by gas engines are abstracted:

The authorities of Duren selected gas engines in 1884 to operate the new water works, being the first to introduce the system. The innovation made a wide impression, and in the same year the city of Quedlinburg replaced its steam pumping plant with one operated by gas engines. In 1886 Rottweil and Coblenz made the same change. Furth and Peirre followed in 1887 and Calsruhe and Munster in 1888—the last employing producer gas, because illuminating gas was not supplied easily. These early plants have now been running a number of years with satisfactory results. According to a report of the Quedlinburg water works, the cost of fuel for raising a million gallons of water was about \$18.12 with coal and about \$9.68 with gas. The water works of Carlsruhe offer an example of the advantageous union of steam and gas pumping plants. The former is the older, and the gas engines are installed within an annex to the building in such a manner that all the machinery is in a single room and under the supervision of one engineer. The increase of the plant by two gas pumps has required no addition to the number of employees, and but a slight increase in the extent of land occupied. The water level of the section and the limited available space led to the selection of deep, vertical pumps. The ground floor of the annex is only 54 feet by 33 feet. It con-

tains two sets of pumps, each of a capacity of 55,000 gallons per hour, raised to a height of 154 feet. The two 50 H. P. engines make 140 r.p.m. and the pump cranks 38 revolutions. The pump pistons are $1\frac{3}{4}$ inches in diameter and have a stroke of 32 inches. From the air chambers common to both pumps a 20-inch pump leads to a junction with the force main of the steam plant and with the 24-inch pipe to the water tower. An 18-inch pipe branches out from the first-mentioned line between the air chamber and the junction, so that water can be pumped through it directly to the distributing pipes, if so desired.

In all these early plants the power was transmitted by means of gearing, and, though this has served its purpose, an attempt has been made in more recent plants to avoid its use, especially because of the troublesome noise. The gearing was principally necessary on account of the great difference in rotary speed of the motors and pumps. In recent years there has been an essential improvement in the construction of pumps, and there is no longer any difficulty in securing power pumps which will run at 60 to 80 r.p.m. without jar or noise. In comparing the duties of steam pump plants the number of foot pounds of work done per unit of fuel burnt is often taken as the basis of comparison, and in gas engine pumping plants the number of foot pounds per cubic foot of gas may be used similarly. The variation between the thermal value of illuminating gas in different cities is probably less than that between the thermal value of different coals, so that the comparison on this basis is probably more accurate than that of steam pumps.—*Water and Gas Review.*

The oldest installations of gas engines operated with coke-oven gas in Germany are said to be those of the Altenwald Kokerei in the Saar district and at Skalley in Oberschlesien, which have been at work for ten years. A large number of similar installations have, however, been erected in recent years. The Ruhr coke making district is taking the lead in this application of the waste gases to motive power purposes; and installations aggregating 6,000 H. P. are now in course of erection.



London expects to have 500 motor omnibuses operating in its limits within a year.

There are about 270 automobiles in use in East Flanders, the most popular machines ranging from 12 to 26 H.P.

During the last three years the maximum speed of automobiles has increased from 63 to 104 miles per hour.

We have known of gas engines being used to run creameries, churns, etc., but the latest adaptation of this power is to run a suction apparatus for milking the cows.

The motor lifeboat is a possibility which offers special advantages to the designer of a successful boat. There are particular difficulties to be overcome in producing a successful one, and the article in this issue presents some of these features very clearly. Intelligent care and successful operation of the engine usually go together.

Mr. Dugald Clerk does not think that the manufacturers of automobile engines have paid as much attention as they should to the fuel economy of their engines, and rightly calls attention to the fact that fuel economy means not only decreased cost of running, but also a greater mileage per unit of storage capacity. Many an automobilist wishes his engine had been more efficient in the matter of fuel consumption, when he finds himself a few miles from additional supplies with an empty tank.

An English automobile has a ring fixed to the under side of each overhanging valve box. Into this ring is arranged to hook a rod, to the lower end of which is pivoted a lever. One end of the lever is formed as a fork and the other a handle. The fork is to catch under the valve spring, so that by pressing the handle end the tension can be removed from the cotter and its removal greatly facilitated.

Cincinnati is not, we believe, considered particularly strong against the automobile. But here and there in every city there are people who look upon an automobile as a wild beast of some sort, rather than a machine which will eventually revolutionize our systems of transportation, and accomplish economies never dreamed of a few years ago. One of these opponents of the automobile was recently heard to say that if he had his way every automobile would be compelled to go at a rate of not more than a mile an hour, to prevent the terrible accidents which are happening. Such people as this do not, as a matter of fact, know the real figures on the relative number of accidents caused from various sources.

Some time ago there was published in London statistics of the number of accidents which had occurred during a year in the metropolitan district, caused by motor cars, motor cycles, horses and horse-drawn vehicles.

These are given in the accompanying table and speak for themselves:

Cause	To Persons or Property		To Persons	Persons Injured	Nature of Accident		Fatal
	To Property	To Property			Slight	Serious	
Motor Cars	1,624	1,281	462	510	424	73	13
Motor Cycles	193	94	120	130	108	18	4
Horses	445	147	332	337	280	49	8
Horse-drawn Vehicles..	22,113	16,283	7,327	7,584	6,552	842	190
Total	24,375	17,805	8,241	8,561	7,364	982	215

THE TESTING OF GASOLINE ENGINES.

In a lecture recently delivered before the members of the Automobile and Cycle Engineers' Institute of Birmingham, Mr. Dugald Clerk said he thought they were all agreed that improving the thermal efficiency of the gasoline engine was a desirable object. It was often said that the cost of gasoline formed so small an item in the cost of running a motor car that it was not worth while troubling so much about the thermal efficiency, or the amount of power that you could get from a given amount of heat in the form of gasoline. The steam car people, especially, used an argument like that, because they consumed, of course, so much more gasoline for a given power and a given mileage than the explosion or internal combustion engine people did. He thought, although the cost of gasoline was not a large part in the cost of keeping up a motor car, as he knew in his own experience, it was desirable to reduce the consumption of gasoline for many reasons.

The first reason was that in an efficient engine you had less heat to dispose of. Apart altogether from the question of monetary economy, or heat economy, you had less waste heat to dispose of, and that, of course, meant smaller radiators, less trouble with water circulation, less gasoline to carry, or a greater distance on the same amount carried. Then the further point came in that if you used less gasoline you were in the direction of having a much more durable engine. Generally, you had less trouble all around if you had an engine that used as much as possible of the heat entrusted to it. The exhaust gases also were less in volume, and you had less smell. These were all points which showed that from the practical point of view it was desirable for the motor car manufacturer and the engine builder to go into the question of the thermal efficiency of the engine. He did not intend to go into the mechanical details of these engines at all. Of mechanical details they got ample particulars very fully and ably reported in the motor and engineering journals, which nowadays were full of mechanical details. And, again, many of them were motor manufacturers and knew all about their own engines much better than he did.

What he wished to advocate was more testing of the engines, or, at least, if more testing of the engines in the engine builders' places prevailed than he knew of, more publication of the results of tests made for the general good. The emulation among gas engine builders was extreme in the matter of economy, and the emulation had been most effective in reducing the cost of consumption.

In the last twenty-five years the consumption of gas in the gas engine for a given power had fallen by no less than one-half. In about 1880 the thermal efficiency of the best gas engine, the well-known Otto, was 16 per cent. That was if the engine got 100 heat units given to it in the form of fuel—the fuel was capable of evolving 100 heat units—the engine converted into indicated work sixteen of these units, and it wasted the balance. From 1880 to the present day this figure sixteen, representing the efficiency, had steadily increased, and now in a test he made recently, an engine of pretty similar size to the one giving 16 per cent gave an efficiency of 33 per cent. Now, seeing that the competition among gas engine builders had led to this improvement, he would like to see among the gentlemen who were devoted to the automobile engine a similar emulation, so as to increase their efficiencies from the present figure to a figure somewhat nearly what the gas engine gave. The thermal efficiency of an engine, as he had said, was the proportion of the total heat given to that engine in the form of fuel which was converted into mechanical work in the engine cylinder.

To enable one to compare different engines, one should have some notion as to what thermal efficiency could be obtained under given conditions, assuming that all the practical heat losses of an engine were absent. Many years ago, in 1882, he went into this subject rather carefully, and ever since many of them had been working upon it pretty continuously, and now it was very generally accepted that they could determine the ideal thermal efficiency of any engine if they knew two things: the stroke of the engine and the combustion space in terms of the stroke. Suppose they had an engine, and the space swept by the piston,

plus the clearance, was equal to ten units of any kind. If the combustion space was 2.5, the ratio was one-quarter of the total. The ratio, therefore, would be one to four. A combustion space of two would give a ratio of one to five, and so on. It had been thoroughly established that if an engine had no heat losses, and all the heat additions were made in the manner prescribed by the ideal conditions, they could calculate the efficiency from these proportions only. He had a table which had been calculated in that way:

$\frac{1}{R}$	E	$\frac{1}{R}$	E
1-336	1-1061
1-2246	1-755
1-443	1-207
1-548	1-10085

If the compression space was equal to half the total volume, the efficiency of an ideal engine carrying out the cycle that they all used would be .246. Of every 100 heat units 24.6 would be converted into indicated work. Of course, no engine had ever been made where the compression space was only 1-100 of the total volume.

Referring to an ordinary indicator diagram, the lecturer said that in the ideal engine they were supposed to add to their heat while the piston was at the end of the stroke, and to expand without loss or gain of heat, and thus to discharge exactly at constant volume. Now in an engine of that kind with different compressions they had different diagrams, and if they calculated from the compression effect they could determine what would be the efficiency of each of the curves without any other consideration than the clearance volume. It was arrived at, but they could take it that that was exactly what was accepted among scientific men. Now, of course, efficiencies like that would be very little use in practice, unless one had some way of comparing the practical engine with this ideal engine. Well, in the gas engine of ordinary construction a great deal of study had been devoted to finding out exactly what the heat losses were, and how near they could approximate to this particular figure. As a result of these studies it was found that in an engine where they had a cylinder, say from five to eight inches in diameter, and the speeds of ordinary gas engines working, viz., 200 to 250 revolutions, they could get the actual efficiency

from the ideal by multiplying (for that particular size of engine) by .6. Thus suppose that he had a practical working engine with a compression space one-fifth of the total volume, the ideal efficiency of 288, or 28.8 per cent of the whole heat given to the engine, and this was found to be a very close rule indeed. If they found that the efficiency was less than this, they would know there was something wrong. If they took a large engine with the same compression space, say, 14-in. cylinder and 22-in. stroke, they would multiply by the figure .7, which meant that the engine in practice would give 33.6 per cent. Intermediate sizes came between .6 and .7. The gas engine builders had used this rule—at least he and many others had—for a long time for the purpose of finding out whether they had made any mistake in a new design. Generally they knew if the figures of efficiency came below these figures with these particular compressions that they had done something wrong.

Now, for the purpose of studying how far the gasoline engine builders had advanced, he got his partner to go down to Birmingham to the Wolseley Company, who were good enough to place at his disposal one of their 6 H.P. engines, and assisted him in every possible way to make a very careful test of that engine. From the results he found this, that with this Wolseley engine at full load the actual indicated efficiency was .19. They took the indicated efficiency from the brake, plus an allowance for mechanical efficiency—a reasonable allowance. And .19 was a very good efficiency for a little engine—an exceedingly good efficiency indeed. That was at full load. They took the same engine and tested it at three-quarter load, and the efficiency rose to 20 per cent, showing that the maximum load was not the point of maximum efficiency. Now they had got the exact clearance space of that engine, and they had calculated from the formula:

$$E = 1 - \left\{ \frac{1}{R} \right\} 0.41$$

If they wanted the ideal efficiency all they had to do was to take the expression $\frac{1}{4}$, raise it to .41 power, and take that from 1. Calculating in that way they found that the ideal efficiency of the Wolseley engine was 43 per cent. Now if they divided 19 by 43,

they would find they had 44, the efficiency ratio. Now that told a tale at once.

It told them that the gasoline engine builders had not yet succeeded in coming up as closely to the ideal conditions as the gas-engine builders. If they had they would have had an efficiency very much greater than 19 or 20 per cent.

Before he went on to say anything about what that would be, he would like to suggest that gasoline engine builders should make a little more elaborate tests than he thought they did. Gas engine builders were always making tests and trying to beat their neighbors by $\frac{1}{2}$ or $\frac{1}{4}$ cubic foot, and he would like to see the gasoline people fighting about a drop of gasoline. He would suggest that they should first make brake tests. Some of them, perhaps, used the Prony brake, but the kind of arrangement he was in favor of was a rope brake on a hollow rim. It was a very bad thing to put a rope brake on a flywheel. Mr. Clerk proceeded to draw on the blackboard a section of a hollow rim bolted to a flywheel, the rim being hollow both in its inner and outer periphery. He explained that if they put a rope brake on that with two turns of the rope, and ran a little water inside the hollow rim, the centrifugal force kept the water always clinging to the periphery, and every part of the rim was covered in that way with water, and there was no difficulty in keeping it cool without any mass of water. Another advantage was that the rope brake did not vibrate. The Prony brake was a little apt to vibrate, and the spring readings were not quite accurate.

The next thing was the indicator, and the indicator for the gasoline engine was a very difficult problem, indeed. The ordinary indicators were practically of no use for gasoline engine work. The indicator, however, was not so important if they had a brake; that was the first thing they wanted.

Then they wanted to have a calorimeter for determining the heating power of the gasoline.

One of the first essentials of gasoline engine testing was to get the exact number of units of heat a given quantity of gasoline would give. It was quite impossible to try and reason about an engine unless they knew exactly how much heat they were giving. He would strongly impress upon gasoline engineers the

desirability of testing the gasoline in that way. They would have found that an engine ran very well with a given gasoline, and would not run so well with another gasoline, and one reason was that the heat given might be higher or lower, and the vaporisation perfect or imperfect, and they would see they wanted to know what was the heat volume. Then the fourth thing was to have the heat flow from the water jacket. They wanted to run the water through the jacket, and run it at a very constant rate, and then take the temperature difference between the water flowing in and the water flowing out. In that way they got the heat going through the jacket, and could determine the ratio lost due to that.

Then a new arrangement had been introduced which had been used by a committee at the Institute of Civil Engineers to determine the thermo-dynamic standard for all kinds of internal-combustion engines, and they had been developing an exhaust gases calorimeter, so in that way they could measure every heat quality; they did not leave anything to be measured. In addition to these things, to make the test valuable from the scientific point of view, and the reasoning point of view, it needed, of course, the principal measurements of the engine, speed of rotation and especially (an important thing) the volume of the clearance space enabled them to calculate the ideal efficiency. Now, if this Wolseley engine he had been testing had been relatively as efficient as a small gas engine of not much larger cylinder, say 5-inch bore by 9-inch stroke, running at a slow speed, the Wolseley engine, which had an efficiency of 20 per cent as the highest, should have had an efficiency of $.43 \times 6$ equals 25.8. That meant that in this gasoline engine there was a greater loss somewhere than was incurred in a gas engine. One at once asked oneself why was this? Why was the efficiency not higher, and how could one alter the engine to make it higher. All he could tell was that it was not possible to predict that; there was very little recorded at present of the conditions under which the consumption varied in gasoline engines. He could tell them that there were certain general conditions under which every engineer outside the gasoline engine people had accepted:

1. High compression; as high as they could get without pre-ignition.
2. Minimum cooling surface to which the flame is to be exposed.
3. Shortest time of exposure.
4. Lowest flame temperature consistent with rapid ignition.

First he would like to say a little about the shape of the compression space as bearing upon the question of economy. The Wolsley engine happened to have an exceedingly good compression space, which followed very closely the lines of a first-class gas engine. The piston came very nearly clear up to the end of the cylinder, and the space was a simple rectangular aperture.

Other things being equal, the engine, with a space having the two valves on each side of the cylinder, although very mechanically convenient, was at a disadvantage from the point of view of surface.

It had always been found in gas engine construction that to have the inlet valve opposite the exhaust valve was not an economical arrangement. They have never got so good economy when they had the gases from the inlet valve pouring against the exhaust valve. It reduced the economy of the engine by increasing the temperature of the gases entering the cylinder. The consequence was that most modern gas engines were constructed with the exhaust valve at the bottom of the cylinder, and the inlet valve as far away as possible. It was a point which was not much attended to in gasoline engines yet. He did not wish them to think for a moment he was finding fault with gasoline engine builders, because he admired very much the beautiful, ingenious mechanical features, and the builders of slow engines had a great deal to learn from the results that had been obtained from gasoline engines. He had no doubt that by properly going into these matters experimentally, by a series of tests made by the builders interested, they would soon come to a standard type, as they in the gas engine business had come to. They would never get to a firm standard with high efficiencies until they experimented a little more in the way of testing engines they had. The main

point at which it seemed to him the gasoline engine slightly failed was in the filling up of the cylinder. In gas engine construction they found it necessary, even at the moderate speeds at which they worked, to hold open the inlet-charging valve mechanically, considerably over the point at which the crank terminated its stroke, almost until the crank had got 40 degrees over the stroke, and in that way they made sure that they filled up the cylinder and got a full charge. It was very important to begin at the charging end—to get the cylinder properly charged with as cool a mixture as they could charge it with, consistent with keeping the gasoline in a vaporized state. Of course, they must fill up the cylinder as much as they possibly could, and keep it as cool as they possibly could. To do that involved inconsistent conditions, as they wanted to make the charge cool and keep the cylinder warm. All they could do was to make a practical compromise. In gas engines the best economy was always attained with the cylinder at about 80 degrees Cent. But if they arranged their valves so that the gases heated as they went in, they would find that the economy dropped very rapidly. It seemed to him, from what he had seen of their gasoline engines, that they did not get the full charge that they got in the gas engine cylinder, and that they also tended to overheat the charge as it entered. After they had got their charge, not full and overheated, to get all the power they wanted out of their engines, they tended to use too high internal temperatures. Now if they had the mixture heated when it should be cool, and they wanted the power of the engine, they tended to press the temperature up to the highest possible point that the engine would stand without pre-ignition. In gas engines they had found it was a very much better thing to lower the temperatures, and in getting the highest economies that he had ever got, he dropped his upper flame temperatures from the usual 1,700 degrees Cent. to about 1,200 degrees Cent., and by taking care to fill up the cylinder one got just as good average pressures on the low as at the high. He would have liked to go into the question of efficiency of these engines at light loads, but that was rather a long story.

WHY CYLINDERS MUST BE COOLED.

If the ordinary owner or maker of a gasoline engine is asked why the cylinder must be cooled he may say that it is necessary in order to permit of proper lubrication, or to prevent preignition. But the chances are that he will reply that the cylinder must be cooled to prevent heating and expanding the gases after they have entered the cylinder, or simply that it is necessary to cool the burned gases. He seems to think that the heat of the explosion should be dissipated as rapidly and as completely as possible, and that the cylinders should be kept as cold as possible all the time.

Nothing could be farther from the truth. As a matter of fact one of the greatest elements of loss and inefficiency in the gasoline engine today, especially with small units, is the loss of heat through the walls of the cylinders. The heating and expanding of the gases is the very life of the motor. Without the expansion the engine would stop, and without the heat the expansion would disappear. If the heat is extracted too soon the efficiency is impaired.

The heat and consequent expansion of the gases in the cylinder are caused by the combustion or chemical combination of the gasoline vapor and air in the cylinders; but if the heat is removed as soon as the chemical combination takes place there will be no pressure to start the piston in motion.

Gasoline is a compound of carbon and hydrogen, or a mixture of several similar compounds. This, in a state of vapor or gas, is mixed with air consisting of one part of oxygen and four parts of nitrogen. The hydrogen and carbon in the gasoline combine with the oxygen forming carbon dioxide and water leaving the inert nitrogen as before. If the products of this combustion are cooled and their volumes measured at the original temperature, it will be found that there has been hardly any perceptible change in volume. According to Avogadro's law, the chemists tell us, we should find the following state of affairs: 1 volume gasoline plus 11 volumes oxygen and 44 volumes nitrogen equal 7 volumes carbon dioxide and 8 volumes water plus 44 volumes nitrogen.

Fifty-six volumes become fifty-nine vol-

umes. But if the temperature is brought down below 212 deg. Fahr. the water vapor condenses and removes the eight volumes of water, leaving the resulting products of combustion occupying less space than the original mixture. With the heat of combustion left in, however, the volume or pressure are enormously increased, and it is from that increase that the motor derives its power.

So one can readily see the importance of not cooling the gases, but of keeping them hot till the end of the stroke, and then permitting them to exhaust into the open air. For this purpose the cylinder walls should be kept hot, instead of being cooled. Indeed thousands of motors are in every-day use which depend entirely for their pressure upon the gases heated inside the cylinder by means of a hot cylinder head. Instead of being cooled by water jackets the cylinders are heated by flame jackets. The well-known Ericson and Ryder hot air engines are examples.

So much for the erroneous notion that the exploded gases should be immediately cooled.

The attempt to prevent the heating of the gases admitted to the cylinder, is also a mistake. In the hot-air engines just mentioned the only source of power is that obtained by heating the gases after they are admitted to the cylinder and somewhat compressed. The gases (air) are made to pass by the hot end of the cylinder or through a heater connected therewith called a regenerator, which heats and expands the gases and thereby drives the piston back, to draw in a new charge, with power to spare. If the cylinder head of an ordinary gas engine could be kept red hot from the outside the engine would run on a supply of cold air alone. It would become a hot-air engine. The heat cycle would be as follows:

- (1) Draw in a charge of cold air.
- (2) Compress the air against the cylinder head.
- (3) Air becomes hot, expands, and drives back the piston.
- (4) Hot air expelled to make room for new charge.

In the gasoline engine the heat is introduced into the cylinder by combustion of the gases themselves, which is a conveni-

ent and quick method of heating them. But if a hot cylinder head would heat them as rapidly and as conveniently and at the right time, it would answer as well. So we need have no fear of heating the gases after they have once been compressed in the cylinder. It is rather to be desired than feared.

That leaves but two reasons suggested for cooling the cylinders—to prevent pre-ignition, and to permit lubrication, and these, it seems, are the true and only reasons why the cylinder should be water-jacketed at all.

Pre-ignition can occur only when some part of the cylinder is left so hot by one explosion that it will ignite the following charge prematurely. The only parts that are likely to become so hot are the parts about the exhaust valve. The makers of hot-air engines who desired to heat their gases found that only a thin layer of air could be rapidly heated even by a red-hot plate; and the converse of that proposition is also true. Only a thin layer of gas will impart its heat to a neighboring plate. The rest of the gas will retain its heat quite a length of time. But at the narrow opening of the exhaust valve, where all the gases pass in thin streams, a great proportion of the heat will be imparted to the metal parts, and if the temperature becomes high enough the next charge may be ignited before the proper time. This danger, however, is not nearly so great as is commonly supposed. A very small flame or spark will ignite the gas mixture, but not a red-hot piece of iron. If a lighted match is thrown into a pan of gasoline it will take fire; but if a lighted cigar is thrown into it the "coal" will be quenched almost as rapidly as by water. The writer has several times had a leaking spark plug get hot from the "exhaust" through the leak, and yet no pre-ignition occurred.

Some of the early stationary engines exhausted first through a port, which the piston uncovered at the end of the stroke, like the exhaust port of a two-cycle engine. This left very little of the hot gases to be driven out through the regular exhaust valve, and kept it comparatively cool. There seems of late to be a tendency to return to this double exhaust, notably in the Peerless and Knight engines. It removes much of the danger of pre-ignition.

There remains to be considered the matter of lubrication. The temperature of the

cylinder walls where the piston travels must not be so high as to decompose or carbonize the lubricating oils—for as yet nothing has been discovered to take the place of oil. Heavy cylinder oils can be obtained that will not carbonize till the temperature reaches 400 or 500 deg. Fahr. (lead melts at 600 deg.), and that part of the cylinder within which the piston travels back and forth must be kept below that temperature if lubrication troubles are to be avoided. While, as stated above, heat is conducted but slowly from one layer of air to another, it is conducted rapidly from one layer of metal to another. We find, on examination, that the lower end of the piston, nearest the shaft, soon becomes very nearly as hot as that part in contact with the hot gases. Whatever heat is imparted to the upper end of the piston is conducted rapidly throughout its body, and also to the cylinder walls with which it comes in contact. Therefore the entire piston travel should be cooled, and no more, because that is the only part that requires lubrication.

This, we know, is contrary to the practice of the early engine builders. They jacketed the heat of the cylinder and not the side walls. At the present day makers jacket the side walls anyway, and sometimes leave the head unjacketed.

In the matter of the shape of the combustion chamber, too, a gradual change can be observed, owing to a better understanding of the heat problem. Formerly, for convenience or other reasons, the inlet and exhaust valves were frequently located on opposite sides of the cylinder, in separate chambers. This gave ample opportunity for a tremendous cooling of the gases, which at that time was considered desirable, and caused a great decrease in the efficiency of the engine. Later builders made the cylinder head more compact and placed both valves in one chamber on one side of the cylinder. They extended the water jacket down the sides of the cylinder, but only partially covered the piston travel.

In several 1905 engines, for example the Welch and the Knight, the cylinder head is made hemispherical, and there are no valve chambers whatever. The valves open directly into the sphere. Even the piston is hollowed out to complete the spherical shape of the combustion chamber, for, of all geometrical figures the sphere has the greatest volume enclosed within the smallest surface; a spherical combustion cham-

ber, therefore, will admit the greatest volume of gas with the least surface to cool it.

A supplemental exhaust is opened or uncovered by the piston at the end of its downward stroke and permits most of the gas to escape into the muffler. The regular valve may well exhaust into the open air, as it is useful merely to scavenge the cylinder—and through it escapes but a small

amount of air, and that small amount is under no pressure.

There seems to be a tendency to remove the water jacket from the cylinder head entirely, and locate it around that part of the cylinder within which the piston travels, for the main purpose of all cooling devices is to permit proper lubrication of the piston.—*Automobile Review*.

AUTOMOBILE FOR LAUNDRIES.

At the sixth annual convention of the Ohio Laundrymen's Association, held in Cleveland, March 13 and 14, one of the topics discussed was: "Is it practical to employ the automobile for call and delivery?" The discussion of the subject showed that the laundrymen of Ohio had been considering the subject of automobile delivery with considerable interest. The steam machine was not referred to in the discussion, which would seem to show that steam laundrymen do not consider steam delivery wagons suitable.

The electric automobile was at once pronounced impractical, for several reasons. First, it is not possible, at least at the present time, to secure an electric truck built for a load of less than two tons, which type of truck would cost \$2,700. A one-ton truck could be secured, but the purchase price would be about the same. Now, laundry bundles are not heavy, and the question of delivering this class of work is not so much one of the delivery of a load, but the quick and accurate delivery of many packages.

Another objection to the electric machine was the time involved in recharging the batteries. Laundry delivery wagons must cover long routes and be out for practically the whole day.

The main objection expressed against the gasoline machine was the fact that there must be many stops to carry packages from the wagon to the house, etc. The large cities have ordinances preventing operators from leaving a gasoline car without any attendant unless the engine is stopped. To stop the engine while getting or delivering laundry and then to start the engine each time a call is made is an objection.

The securing of competent drivers was also mentioned as a difficulty, but as the

gasoline machine increases in number this difficulty will decrease.

The gasoline car was admitted to do the work of at least two horse-driven wagons, to be a most excellent investment in the way of advertising the laundry and to answer better than any other type of car the needs of the laundry for delivery. And the opinion of the laundrymen seemed to be that if the above-named objections could be overcome in some way the gasoline delivery wagon would prove an ideal machine for the laundry.

One thing that was not discussed by the laundrymen was the comparative expense of gathering and delivering laundry by horse or by automobile. The cost of delivery by horse was taken up at one of the sessions merely to compare notes on the cost to the laundry of maintaining a collection and delivery system. The actual cost, figured as a percentage of the money received for doing the laundry work, varied quite materially in different laundries. While this portion of the proceedings was stricken from the minutes, and the writer is not at liberty to give any figures, these being deemed personal property of the laundrymen, yet from the figures given for the cost of this department it is quite evident in the writer's mind that this cost may be materially reduced by the use of automobiles, the reduction being due primarily to the increased radius of action of the automobile and the decreased cost of men employed. From the figures given by at least one laundryman, the salary of an automobile operator would be no more than he is now paying his horse drivers, while the number of wagons is twice as many as he would require for an automobile service, and he also employs quite a barn service at present.

AUTOMOBILES FOR DRY GOODS MERCHANTS.

Among the retail dry goods dealers of the United States, a quarter of a million strong, a quick, effective, attractive, light delivery service is most essential.

When a woman buys an article at a drug store, no matter what it weighs, she willingly carries it home. If she buys a spool of thread at a dry goods store she orders it delivered. If she buys it at 3 o'clock, moreover, she wants it at her door at 5. The telephone still further complicates matters with store keepers

Customers living several miles from the business district call up and order articles which they want delivered within a few hours. The store keeper must deliver them or lose his trade. So the store keeper delivers them. He makes enough profit probably to afford the expense, but at present he delivers them by horse and wagon.

An automobilist knows he should not do this. He should have an automobile delivery wagon, which would be cheaper than horses, quicker than horses and better than horses in every way.

The only reason the dry goods store keeper does not use automobile delivery wagons, according to a prominent wholesale merchant, is because they do not know the advantages nor the simplicity of the motor car. The light gasoline car is peculiarly fitted for use by dry goods merchants. Their wares are not heavy nor large in bulk. Quickness and speed is what is needed in delivery, not enormous power.

Another point is the automobile's attractiveness—its novelty. Women in many cities habitually buy goods from the firm which has the handsomest delivery wagons, so they may have the envy of their neighbors when the goods are delivered. This is a fact. Here the automobile would fill the bill, and it is only a question of time and education when the dry goods merchants of the country will all use automobile delivery wagons. They must come to it. Instead of not affording them, they will not afford to do without them.—*Automobile Review*.

MOTOR BOAT RATING.

"M. P.," which denotes "motor power," is calculated by an empirical formula introduced by the Marine Motor Association, and is rather a measurement of the engine than an expression of actual horsepower. The "M. P." is calculated from the bore and stroke of the cylinders, taken in conjunction with the normal engine speed, and the formula used is as follows:

$$M. P. = \frac{A \times S \times R}{C}$$

in which A = the total piston area in square inches, S = the stroke in feet, and R = the r. p. m.

The divisor, C, is a constant which differs according as to whether the engine works on the 4-stroke (Otto) cycle or on the 2-stroke cycle, being taken at a value of 1,000 in the former case and 600 in the latter case. To take a couple of instances: The "M. P." of a single-cylinder 2-stroke engine, having a 5-inch bore, a 6-inch

stroke and a normal speed of 400 r. p. m., would be 19.935 (the area of the 5-inch piston) multiplied by $\frac{1}{2}$ (the 6-inch stroke, in feet) multiplied by 400 (r. p. m.) divided by 600 (the constant for 2-stroke motors), and this gives 6.5 as the "M. P." Similarly, the "M. P." of a 4-stroke, 4-cylinder engine, having a bore of 4 inches, a stroke of $4\frac{3}{8}$ inches, and a normal speed of 1,000 r. p. m., would be four times 12.5664 (the total area of the four pistons)

multiplied by $\frac{4\frac{3}{8}}{12}$ (the stroke in feet),

multiplied by 1,000 (speed), and divided by 1,000 (the constant for such an engine); this gives 18.3 as the "M. P." It will thus be seen that the "M. P." of a gasoline engine does not necessarily bear any precise relationship to the actual B. H. P. that it is capable of giving, even at normal speed, but that it forms a convenient basis for use in certain boating competitions where no

actual measurements of B. H. P. can be obtained officially.

It is interesting in this connection to mention that a suggestion is now under consideration for increasing the value of the constant, C, in the above formula, for engines using kerosene instead of gasoline. Such very diverse opinions, however, are held concerning the relative power capabilities of engines of the same size, employing these different kinds of fuel, that the M. M. A. will naturally have a good deal of difficulty in fixing a value which will satisfy anything like all their members. The fact of the matter is that it all depends upon the manner in which kerosene is employed, as to whether the maximum output of a given engine is even higher, or is considerably lower, than when running on gasoline in the usual way.

Quite recently the rating rule adopted by the M. M. A. for the boats themselves has been altered in such a way as to favor boats of moderate power when competing against purely racing boats.

The formula as now adopted is as follows:

$$\text{Rating} = \frac{P^2}{A} + \sqrt{L}$$

in which P = the "M. P." referred to above, A = the area of immersed midship cross-section in square feet, and L = the overall length in feet.

Hitherto, the rating was arrived at simply by multiplying the length and the power together, and then dividing these by the immersed cross-section, but it has been

obvious, from the results of the past season's racing, that the length of the boat has relatively little bearing upon the speed as compared with the effect produced by increased power. Now, as will be seen, higher engine powers increase the rating very greatly, while greater length has considerably less effect upon it than before.

Curiously opposed to this, is the even more recent action of the first International Motor Boating Congress, held in Paris, the delegates having passed the following formula for cruisers, viz.:

$$\text{Rating} = \frac{\text{Length} \times R}{\text{Displacement}}$$

This rule is to

come into force in 1906, when it will govern all international motor boat races taking place in that and following year. Racing boats are to be classified solely by length.

We notice, too, that the A. C. F. and the Y. C. F. have now adopted a formula for determining the "length" of a boat. This formula is as follows:

$$L = \frac{L^1 + L^2}{2}$$

where L is the "length" for the

purposes of rating, L¹ the length of hull between perpendiculars, and L² the length on the water line. Hitherto only the length of hull has been considered, but, under the new rule, boats having an overhung bow or stern will be able to take advantage of their short water line and enter in a lower class, so far as "length" affects the question.—*Automotor Journal*.

TRADE PUBLICATIONS.

Cavanaugh & Darly, 30 West Randolph street, Chicago, Ill., are sending out a mailing card showing a new pumping jack.

Marine motors from 1½ to 30 H. P., in single, double and triple cylinder types, are shown in a catalogue from the Sterling Engine Co., Buffalo, N. Y.

"The Power Behind the Boat" is the name given by the Cushman Motor Co., Lincoln, Neb., to their motors, which are shown in a very well printed catalogue just received.

Catalogue 39 from Patterson, Gottfried & Hunter, Limited, 150 Centre street, New York City, is devoted entirely to blacksmiths' tools and contains a very complete list of them.

"The Capital of Pennsylvania is the Strongest Engine on Earth," is the title of a folder received from C. H. A. Disinger & Bro., Wrightsville, Pa. The half-tones are large and exceptionally clever, so that all of the details of engines can be seen by the readers. Stationary, portable and traction outfits are shown.

The Fay & Bowen Engine Co., Geneva, N. Y., are sending out a catalogue of their marine engines, accompanied by some literature relative to English reliability test, etc., which is of considerable interest.

The April Graphite, published by Jos. Dixon Crucible Co., Jersey City, N. J., contains many hitherto unpublished illustrations of notable bridges and buildings in different parts of the world. It also contains seasonable talks on good paint and good painting.

"Dean Gas and Gasoline Engines. What? How? Where?" This is the subject and these are the questions answered by a new booklet issued by the Dean-Waterman Co., Covington, Ky. A convenient feature of the booklet is a list of purchasers of Dean engines, the names being arranged by trades, so that if one

wishes to learn where Dean engines are in use doing some particular class of work this is easily accomplished.

The new edition of "Hart-Parr Blue Book," issued by the Hart-Parr Co., Charles City, Iowa, contains much information of value to those interested in traction gasoline engines, and cooling by oil. Several types of engines are shown in the catalogue and we notice a number of changes in the engines from last year's design.

The Brew-Hatcher Co., Cleveland, O., manufacture a large line of automobile parts, specialties and novelties. These are shown to advantage in a number of loose sheets which they are sending out. Among other things there are shown two cylinder double opposed motors, rated at 16 H. P. and four cylinder vertical 16-24 H. P. motors.

INDUSTRIAL ITEMS.

In a recent contest in France a motor cycle ran 12½ miles on .7 of a pint of fuel.

McDonald & Erickson, 42 West Randolph street, Chicago, Ill., are making a specialty of marine engines sent a distance of 1,000 miles on fifteen days' trial.

The Carl Anderson Co., Chicago, Ill., builders of the Gus gas and gasoline engines, have moved into their new large quarters at Huron and Kingsbury streets. Their old plant, located at North Clinton street, was destroyed by fire some time ago, but they are now in full running order.

The Symms & Powers Co., heating and ventilating engineers of Sioux Falls, S. D., have added an electrical department, in charge of Mr. R. R. Keely, M. M. E., until recently engineer with the Westinghouse companies, of New York. They will continue in heating and ventilating work and will take up power station work, including power generation and electric transmission in its various applications, and will also be prepared to take contracts in sewage and water supply systems. They expect to do a large amount of gas engine work.

The Jackson (Mich.) Engine & Motor Co. has changed its name to The Field-Brundage Co., and has increased its capital stock from \$30,000 to \$60,000. The company builds the Miller and the Field stationary and portable gasoline engines from 3 to 50 H. P., and will erect a 300 by 60 feet building. The officers of the company are: President, L. H. Field; Vice President and General Manager, W. D. Brundage; Secretary and Treasurer, Rayner Field; Sales Manager, C. H. Rittenhouse.

The New Era Gas Engine Co., of Dayton, O., have just installed in their machine shop a 60-inch Colburn boring mill, which is intended to finish flywheels in almost one operation by the use of four or five automatic heads. With this machine the flywheels will be finished as nearly perfect as is possible for a modern machine to do in about one-fourth the time usually required. This company also expects to install a new cylinder boring machine of the latest improved type, which, added to a number of new machines recently added to their works, will enable them materially to increase their output and at the same time build the engines mechanically perfect.

THE GAS ENGINE.

STATIONARY—AUTOMOBILE—MARINE.

PUBLISHED MONTHLY BY

The Gas Engine Publishing Co.

Blymyer Building, Cincinnati, Ohio.

ADVERTISING RATES ON APPLICATION. Address All Communications to the Company.

Entered at the Postoffice at Cincinnati, Ohio, as Second Class Matter Feb. 20, 1899.

VOL. VII.

MAY, 1905.

No. 5.

Domestic Subscriptions, \$1.00 per Annum.

Single Copies, 10 cents.

Foreign, \$1.50 per Annum.

It is reported that an English firm is building a 40-foot boat, to be equipped with a six-cylinder motor of 300 H. P.

Why is it that some people, in comparing the jump spark and break spark ignitions will use a \$10 coil for the former and an 80-cent coil for the latter, and then consider that both systems have been given a fair trial?

Quite recently in the English House of Commons the Secretary to the Admiralty stated, in answer to questions, that the Admiralty was conducting experiments to prove the value of boats powered by internal-combustion engines, for naval purposes, but that it was too early to arrive at a definite decision as to their adaptability.

As a rule, it is a good thing to remember when an engine stops that the engine has run and will run again, unless the conditions are changed. In case of trouble, it is useless to pull at the engine for a long time in a vain effort to make it run. The thing to do is to look around and discover what has been forgotten, whether the fuel has been exhausted, whether the ignition current is good, etc. Once these sources are examined the cause should be readily discovered.

The importance of a proper grade of lubricating oil is something which many engine users do not realize. They sometimes think that steam engine oil is good enough for steam engines, and therefore good enough for gas engines. While it costs more money per gallon than gas engine oil, it is not fitted for the work of lubricating gas engine cylinders, where the conditions are so different from the steam engine cylinder. One gas engine expert says that he

has found losses varying from 10 to 15 per cent of the power of the engine due to the use of poor lubricating oils, and we have seen engines which appeared to be losing even more power for this same reason.

In contemplating the adoption of a suction gas producer for use with an engine of any given horse-power, it must be borne in mind that the rated power of engines in this country is usually based on the use of gasoline as fuel, or the natural or city gases commonly secured. While a gas engine designed and adjusted for natural gas of approximately 1,000 B. T. U. heat value will give a different quantity of brake horse-power when it is operated with city coal gas of about 600 to 800 B. T. U., yet this is often done in the smaller units without material decrease in power, providing the engine is best adjusted to the new fuel and is sufficiently large to meet the requirements of the machinery operated.

But in changing to producer gas we have a fuel of very much less heat value than even city coal gas, being in the neighborhood of 150 B. T. U. This means a very necessary change in the valves, their adjustments and the compression. And in endeavoring to convert, say an 80 H. P. gasoline engine to suction gas, we must count on considerable less power than 80 H. P. being developed by the engine. Not only will the decrease in power be expected, in view of the nature of the gas, but in the suction gas plant some power is lost in the process of sucking the gas through the various parts of the producer. Various estimates have been made as to the actual percentage of loss in power of a given size engine on city coal gas changed to suction gas. One gas engine expert figures a loss of nearly 30 per cent, while Mr. Oswald H. Haenssegen states that it is about 20 per cent.

BRITISH COAL SUPPLIES.

The final report of the Royal Commission on coal supplies was issued some time ago. Their purpose was to find how the coal supply could be conserved, either at the mines or at point of use. The scope of the inquiry covered the resources of the coal fields, probable duration of deposits, possible economies, effect of coal exports and effect of competition in the world's coal markets. It is estimated that there are 100,914,668,167 long tons of coal yet available, and, at the rate of present consumption, 5,694,928,507 long tons during the period 1870 to 1903, the proved supply will last for some time to come.

The consumption of coal in Great Britain during 1903 is given as 167,000,000 long tons.

Mr. Beilby estimated that of this total, from 40,000,000 to 60,000,000 tons could be saved by possible economies. About 52,000,000 tons were converted into steam yielding a horse-power per hour for each 5 pounds. He thinks it should not exceed 2 pounds. This waste is due to small, isolated plants, and could be lessened by using gas engines, but better by central power stations. The use of economizers, automatic stokers and mechanical draft is recommended, as well as analyses of chimney gases and ashes; also, superheating steam and use of exhaust steam for heating purposes. Steam turbines were well spoken of.

They estimated that for every 100 long tons of pig iron made the waste gases produced by the furnaces amounted to 1,000 H. P., and if all this were utilized it would be equal to from 2,000,000 to 3,000,000 tons of coal annually. Coke ovens carbonizing about 7 tons of coal per day give off waste gases equal to 40 H. P. when used in a gas engines. The report continues:

Gas Engines—These are now established as the most economical of heat motors, and it is said that if the average steam engine and boiler installation of today, with its average consumption of 5 pounds of coal per horse-power per hour, were entirely replaced by gas producers and gas engines, the 52,000,000 tons of coal, which it is estimated by Mr. Beilby are consumed for power purposes at mines and factories, would be reduced to 11,000,000 tons. The

possibility of this enormous economy seems to be established by results of many trials by which it is proved that power can be generated by gas engines in almost any locality and on almost any scale with the consumption of 1 pound of average slack per 1 H. P. per hour. The general introduction of gas engines and the use of producer gas could not, therefore, fail to have an important effect upon our coal consumption.

At the time when gas engines were restricted to the use of ordinary illuminating gas the conditions under which they could be used were greatly limited, but even then considerable advances were made. The next step was the successful application of fuel gas made from coke or anthracite to the ordinary gas engine, but little real progress was made until the successful application of producer gas made from ordinary bituminous slack. Even now it can not be said that the gas engine has reached its final stage of perfection, and there appears still to remain a large field for the attainment of increased efficiency both thermally and mechanically.

Producers—According to the witnesses, much economy of fuel results from the use of producer gas plants, but this depends on several conditions, especially their size and their load factor. The fullest economy is obtained in large plants of 4,000 H. P. and upwards, with recovery of by-products, in which case the cost of the coal is balanced by the value of the by-products; without recovery of the by-products it does not pay to put down plant for bituminous coal of less than, say 100 H. P. On the continent small anthracite plants are put down to 10 H. P., and in this country some are in use of 20 H. P. Up to at least 100 H. P. anthracite or coke plants are the most economical, but as to plants beyond 100 H. P. the opinions of witnesses differ, some preferring anthracite plants up to 250 H. P.

As for the quality of the coal which can be used in producers of the modern type, any coal which does not cake excessively will suit if it contains sufficient nitrogen recoverable as ammonia. Coal with a large percentage of ash can be used, and, according to Mr. Crossley, who has already got good results from coal with 30 per cent of

ash, there is no reason to think that 50 per cent of ash would be prohibitive. It would be difficult to exaggerate the importance of the development of these gas-producing processes, which are said to have rendered practicable the utilization of inferior coal and have thus enormously increased the available resources of the country.

It is in evidence that water gas is a very convenient fuel, if it is possible to obtain an ample supply of suitable coke at a sufficiently moderate price. Compared with producer gas, it has from 2 to 2.5 times the calorific power, and, being practically undiluted with inert constituents, it can be distributed in smaller pipes.

Oil—The employment of petroleum in internal-combustion engines of the gas engine type is a comparatively recent development. In their earlier forms oil engines were practically confined to the use of a highly volatile description of petroleum, such as is now used, under the name of "petrol" (gasoline) for motor cars, motor launches and submarines. For stationary engines, especially of large power, ordinary petroleum, such as is burned in lamps, has long since replaced the volatile products above referred to. The use of these heavy oil engines, as they are called, is rapidly extending, and the still more recent invention of Mr. Diesel shows that a very heavy oil and even crude petroleum can be successfully employed as fuel in an internal-combustion engine. To sum up briefly, any description of petroleum products or crude petroleum itself can now be made available as a source of power, provided that suitable appliances are employed.

Power Production—Before passing away from possible economies in power production, it is necessary that we should refer to the savings which the witnesses anticipate from the increase of central stations for the generation and production of power in bulk. The success already attained by such stations in America, on the continent and in the United Kingdom makes it appear probable that in towns the smaller consumers will in the future obtain a large proportion of their power in this way. It is also said that central power stations scattered over the country wherever a source of power is available, be it coal, water, peat or waste gas, will attract to themselves large users of power.

Hitherto nearly all such stations in this

country have been worked by steam power, and, although there are a few gas engine stations, it is stated that they do not compare favorably with steam engine stations in practice. It is admitted, however, that gas engines ought to and will in future displace the reciprocating steam engine for driving dynamos for large power. As we have already seen, it is claimed for the steam turbine that it will compete successfully with the gas engine. It must be remembered that until quite recently the gas engine had not sufficiently developed to enable it to be used for large powers. There are now numerous cases where large gas engines have proved successful.

Dr. Hopkins, has made an interesting comparison between steam plants and gas plants for central power stations. After giving detailed figures, he sums up in this way:

"Hence it appears that such a central station as has been described, if equipped with gas plant, will involve a capital outlay approximately the same as with steam plant, and that the fuel consumption, if worked at full load continuously, will be reduced in the proportion of 100 to 83, and if with a load factor of 25 per cent, in the proportion of 100 to 35. These figures only represent the actual saving in fuel.

"The economy in the money cost of fuel is much greater, owing to the fact that coal can be used in the producers, which can be supplied at less cost than coal for use in the steam boilers, proportionately to its calorific value and also to the fact that the recovery of the ammonia may be taken as a direct saving in fuel cost equal, in the case of coal used in the producers worth \$1.70 per ton, to a saving of \$1.09 per ton at the highest price of ammonia sulphate."

Further advantages claimed for the gas engine plants by Dr. Hopkinson are that while they occupy about the same space as the steam engine, and while the wear and tear is about the same, the standing losses in a gas engine are lower, and it requires much less water.

The Wyland Manufacturing Company, Williamsport, Pa., are about to establish, in connection with their other business, a sales branch to carry a complete line of gas engines and power transmission machinery. They desire to hear from interested manufacturers.

RECENT GERMAN GAS ENGINES.

From a paper read before the Verein Deutscher Eisenhüttenleute

The first gas engine of high power was introduced by the Oechelhauser Company for pumping purposes, but the credit of the earliest attempt to increase the cylinder diameter of this type of prime mover belongs to the Cockerill Company, which also made the first gas blowing engine. The practice of cooling the piston was introduced independently by Cockerill and Koerting, the latter firm being also the first to use stuffing boxes in gas engines, in the construction of a small tandem engine in 1895. This principle was also applied to large engines by the Cockerill Company and by the Maschinenbaugesellschaft Nürnberg, the latter firm also constructing the largest single acting engines up to 750 H. P.

A new era was opened in 1902 by the introduction of the double acting, two cycle Koerting engine, in which an impulse was exerted at each stroke of the piston; but as it was recognized that this type could hardly compete with the popular single acting, four cycle type, the necessity arose of extending the same principle to the four cycle engine, which was done by both Deutz and Cockerill early in the same year. True, similar engines had already been constructed by Koerting and the Berlin-Anhalt Company, but these were little known. Later in the year the Nürnberg Company abandoned its old type in favor of the double acting tandem engines, of which class of engine it is now the largest maker.

Dealing with the most advanced types now in use, the author starts with the Oechelhauser engine, constructed by A. Borsig, of Tegel. This, for engines over 600 H. P., is of the ordinary double cylinder class. A longitudinal section through the cylinder shows that it is composed of two tubes, meeting at the center and completely separated from the water jacket, in order to prevent strains from unequal expansion. The water jacket on the combustion chamber is connected with that cooling the rest of the cylinder at the top only, so that the cold water is first compelled to circulate around the combustion chamber. The pistons have

single walls, and are closed by removable heads, so that the interior can be easily cleaned. No difficulty seems to have arisen with the exhaust ports or on account of excessive wear of the piston. The engine is governed by regulating the quantity of gas entering through the admission ports. To reduce pumping, the gas is drawn in through the suction stroke, that in the gas main being forced back into the suction pipe during the compression stroke, the opening of the valve being regulated by the governor, so that the gas is not compressed until it reaches the chamber next to the ports. As it was also found advisable to check the influx of air when working under reduced load, a return valve, operated by the governor, has been mounted in the air pipe. Both valves are actuated by the Neuhaus-Hochwald gear, used in the Borsig steam engines. The air main is also fitted with a throttle valve, which assists in distributing the air for purifying the cylinder and mixing with the gas. The gas and air valve apertures can also be varied by slides, both of which can be set by hand when poor gas is being used. For rich gas, however, it is preferred to control the valve slides by the governor, so that in the intermediate stroke the gas ports are closed, except those on about the same line as the igniter, in order to maintain a rich mixture next to the igniter all the time.

The newest form of Oechelhauser engine, constructed by the Aschersleben Maschinenbau - Aktiengesellschaft, has the cylinder in three parts; the middle portion, surrounding the combustion chamber, being separate, but also of cast iron with a solid wall. The gas and air return system is the same as in the Borsig engine, but is operated by König valve gear, and a valve, worked by a valve gear, is also provided in the main for distributing the air for purifying the cylinder and mixing with the gas. There are no slides in the admission ports, and the return valves are rendered more accessible by being mounted above the ports on the cylinder, instead of below the base plate. The charging pumps are

fitted with simple clack valves. The gas consumption and other points in connection with these engines will be referred to later.

In the Koerting engine, the cylinder was formerly cast in one piece with the water jacket, but the strains caused by irregular expansion produced distortion of the admission ports, so that now the cylinder is made in two parts, surrounded by the jacket. The ports are cut out of the solid wall, so that the stay edges are not so hard as when the ports were made in the casting. Underneath, where the piston rests, there are no ports, and here provision is made for cooling the cylinder. The engine is fitted with a piston tail rod and a guide. The piston rods are turned in such a manner that the weight of the piston makes them perfectly true. The cylinder heads are cast solid, except at the upper part where the igniter is mounted. The igniting gear is no longer mounted on a separate shaft, the eccentrics being now placed on the main shaft. Owing to the rapid movement required in the admission valves, they must either be fitted with very strong springs, or else actuated direct, the Siegen Company and the Klein Company (Dalbusch) employing double bowls for this purpose.

In the simplest form of governing (for blowing engine, rolling-mill engines, etc.) the gas pump is controlled by a single valve, with a constant cut-off of 60 per cent in the suction stroke. The governor regulates the volume of gas by a throttle placed in the gas main just in front of the valve chest.

In the four cycle engines, which are mostly of the tandem type, the valve chests are now usually mounted on the cylinder, instead of the cylinder heads. The Nurnberg, Mullhausen and Soest engines employ eccentrics for actuating the valves, these running with less noise than tappets, and enabling the spring pressure on the valves to be reduced, the return motion being effected by the eccentrics themselves. On the other hand, only 15 per cent of the eccentric strokes can be utilized in four cycle engines, and, therefore, the size and friction of the eccentrics must be increased. The rods have also to move at high speed at the moment of opening and shutting the valves, thus necessitating the use of roller levers if a gentle opening and closing movement is desired. These levers also considerably diminish the pressure required for lifting the valves, and are therefore used in the Deutz engines for working the exhaust valves with tappet gear.

THE GAS ENGINE IN THE ARMY AND NAVY.

The internal-combustion engine has recently come under considerable inspection by the armies of the world, since it is not unlikely that it may become a valuable adjunct to the army in the form of power for self-propelled vehicles of various kinds. This type of engine has also been considered by the navies of the world in its possible place as a power for submarine boats, auxiliary launches and possibly eventually in larger units in connection with gas producers. In the third issue of THE GAS ENGINE appeared a note as follows:

"On page 12 of THE GAS ENGINE, June (1898) number, you refer to the difficulties of the army in securing a sufficient supply of good water.

"Perhaps it would interest you to know how the difficulty was met at this place (Tampa, Fla.), as a gas engine was the in-

strument through which a portion of the thirsty army secured relief.

"Some fifty thousand troops came to Tampa, and the strain on its resources, and especially the water supply, was very great.

"All of this large body of men, with the horses and mules accompanying them, could not be accommodated with camp grounds within the area reached by our local water system. On this account General Shafter contemplated the removal of a portion of his troops to some other point.

"In the outskirts of the city there is a beautiful spring with a large flow. This was shown to General Shafter, and he said it would do, but some system of water works must be immediately devised.

"The gas man came to the rescue. Fortunately the President of our company had a new 10 H. P. Charter gas engine, which

had been brought here to operate a cold storage plant. It was turned over to the gentleman who had a contract for the erection of General Shafter's waterworks.

"A rotary pump, 3-inch suction, 2½-inch

discharge, was put in, which supplied a 10,000-gallon tank. The system furnishes from 50,000 to 60,000 gallons daily, and Tampa continues to be the most important base of army operation."

POWER PRODUCTION FROM GASEOUS FUEL.*

By J. R. BIBBINS

In all industrial progress, the keynote has formerly been and is to-day more than ever—Economy. Reared from commercial necessity and fostered by commercial competition, its influence is felt throughout every branch of commercial life in the cumulative reduction of costs of various commodities. As low prices are dependent upon low cost of production, so the latter depends to a large extent upon the efficiency of the manufacturing process and upon the conservation of by-products or wastes.

It is an unfortunate commentary on human progress that where Nature has been most prodigal in her distribution of mineral wealth, man has been most careless in its development and utilization. To be sure, Nature's energy stores are practically inexhaustible and indestructible, but the most convenient sources may be readily dissipated through under-valuation or carelessness, as is the case of our forests and some of our coal, petroleum and natural gas fields. More remote sources must then be located and drawn upon at the extra cost of transportation.

Now that this lesson has been learned, the logical method of practicing industrial economy is by the conservation of waste by-products, as well as of raw materials. This reclamation of waste is, at the present, a problem of vital importance. The refuse of to-day becomes a source of revenue to-morrow, thus increasing the world's apparent wealth, but in reality simply increasing the efficiency of production.

No more fertile field for improvement in this line exists than that of power production. Owing to the prodigal use of fuel, some of the most convenient supplies have to a considerable extent given

out, resulting in a substantial increase in the cost of fuel. This, in turn, has forced the development of more economical methods and machinery.

Hydraulic power is already highly efficient, but, unfortunately, localized. Steam power has practically reached the limit of efficiency under present conditions, although the steam turbine has enhanced this efficiency to a certain extent. Gas power at present offers unquestionably the necessary relief; it presents an opportunity of doubling power plant efficiency, due largely to the elimination of certain wastes attending the use of steam. This opportunity has been only partially realized through the use of natural and illuminating gases and, to a limited extent, waste blast-furnace gas and producer gas.

Producer gas, it is firmly believed, will provide the solution of this general power problem. At present the gas producer is undergoing important development and can not be said to have yet reached fixity of form. The standardization of practice, so important in every industry, is yet far from realization. But the crudities of early form and the fallacies of later development have been largely outgrown, and the very near future will doubtless witness the attainment of two important results in practical service:

85 per cent useful efficiency of producer.

27.5 per cent useful efficiency of gas engine.

$85 \times 27.5 = 23.2$ per cent plant efficiency.

The average manufacturing establishment using steam power consumes about 6 pounds of coal per useful horsepower hour developed. An average central station consumes 5 pounds per kilowatt hour. With steam turbines the latter may be reduced to about 3.5 pounds. Even at 2.5 pounds, minimum figure, there is still lost about 90 per cent of the heat energy of the coal, i. e., the plant

*Extracts from a paper read before the Ohio Gas Light Association.

efficiency is about 10 per cent. This results from:

70 per cent steam boiler and furnace efficiency.

15 per cent steam engine efficiency.

$70 \times 15 = 10.5$ per cent plant efficiency.

This low efficiency may be doubled through the agency of producer gas power, owing to the elimination of the middleman—steam—and direct combustion of gaseous fuel in engine cylinder.

A most important step toward the attainment of this high conversion efficiency in the producer will be the complete gasification of bituminous fuel, including the tar and other compounds. This is all important, and only through its attainment will cumbersome cleaning apparatus be avoided and bituminous coals become generally available for power fuel. Furthermore, the producer will acquire the useful property of being able to gasify solid combustibles in any form, such as peat, lignite, wood, garbage and combustible refuse of all sorts.

We have but to turn to recent statistics to appreciate the rapidity of modern industrial progress and incidentally some possibilities of the future. The total power employed in United States manufactures in the last census year was approximately 11,000,000 H. P. It had increased 90 per cent in the preceding decade and at a constantly increasing rate. Assuming a 10-hour working day and three-fourths of the machinery in service, the total coal consumption approximates

$$\frac{0.75 \times 7.5 \text{ lbs.} \times 10 \text{ hrs.} \times 11,000,000 \text{ H. P.}}{2,240}$$

$= 276,000$ long tons per day, or 85,600,000 tons per year of 310 working days, nearly 30 per cent of the average coal production of the United States in 1901 to 1903, inclusive. At an average cost of \$1.50 per ton, the saving above noted in favor of producer gas power represents something like \$65,000,000 in treasure, disregarding entirely what this saving in fuel means to future generations.

In three States alone—Pennsylvania, Ohio and West Virginia—where gas, liquid and solid fuels abound, about 2,500,000 H. P. is used in manufactures, 28 per cent of the total, and this has doubled in the last ten years. Thus it

may be seen that the fuel problem is not only of present but of future moment.

It may justly be said that in this country the internal-combustion engine is just beginning to be appreciated. That Americans are casting envious eyes upon European successes in this line is sufficient proof of the contention.

To be sure, the American gas engine has not always approached perfection, and is still susceptible of improvement, but, on the other hand, it has not been fostered in the manner that European practice has demonstrated it to have deserved. It has had an uphill fight from the start, a condition not well calculated to bring about its rapid development. But now that its position is definitely established, the future is admittedly bright.

In 1900 the total power of gas engines in manufactories was 143,840 H. P., but 1.3 per cent of the total 11,000,000 employed. But it is significant that its rate of increase during the preceding decade as compared with other prime movers was as follows:

Per cent increase 10 years.

Internal combustion engine	1,511.0
Steam engine	91.0
Hydraulic motors	37.6

In the three above-mentioned natural fuel States the gas power employed in manufactories was 92,100 H. P., or nearly two-thirds of that in use in the entire United States. This is to a certain extent indicative of its localized use. As a matter of fact, the gas engine should have found its best field in sections of the country where fuel is dear and a number of important applications in the North and Middle West and in Mexico have been made on this score. But the enormous field of general power production still remains open to the most efficient prime mover and the advent of an entirely satisfactory producer in connection with gas engines is destined to mark an extraordinary period in the country's commercial development.

The majority of industries produce quantities of organic waste in some form of liquid, gaseous or solid combustible. These wastes have polluted our atmosphere and streams, offended our senses and endangered public health and apparently without being amenable to

legal restriction or public protest, being tolerated as necessary nuisances and essential to industrial progress. This fallacy has step by step been disproved and methods are now available in almost every industry for transforming organic and inorganic wastes into useful commodities.

It is noteworthy that in some of the most important industries organic wastes already exist in gaseous form and are directly available for power production. In others, these wastes have only to be gasified for similar purposes. In these—the majority of industries—the gas producer of the immediate future opens up a vast field, practically undeveloped, for the economical production of power, as its distinctive property will be the ability to transform into combustible gas solid organic matter in whatever form.

A few important industries yielding wastes available for power are as follows:

It will be observed that the iron and steel industry not only utilized the most power, 1,670,547 H. P., but also the highest capacity per establishment, 2,500 H. P., and with one exception showed the greatest progress, 124 per cent in 10 years.

A modern blast furnace, according to several authorities, yields something like 140,000 cubic feet of gas per ton of pig produced. This gas averages about 90 effective B. T. U. per cubic foot and is suitable for heating and power in the following approximate proportion:

25 to 30 per cent used in hot blast stoves.

15 (more or less) per cent used for accessory power.

50 to 60 per cent, surplus, available for power.

This surplus alone has been valued at from 50 cents to \$1 per ton of pig iron produced, according to the salability of

TABLE I. BY-PRODUCTS AND WASTES AVAILABLE FOR POWER.

Blast-furnace gas	Iron and steel.
Coke-oven gas	Coke.
Oil-gas distillates	Oil refineries.
Garbage—organic refuse	Municipalities.
Sawdust and refuse	Lumber.
Spent tan bark.....	Leather.
Bark and trimmings.....	Paper and wood pulp.
	Furniture factories.
Wood and other combustible refuse.....	Carriage factories.
	Car shops.
	Agricultural implements.

The amount of power used in 12 classified industries is shown in Table II.

TABLE II. UNITED STATES INDUSTRIAL POWER IN 1900.

1. Iron and steel	1,670,547	14.8	124.0	2,508.3	94.7	0.5	4.8	
2. Lumber and timber products	1,613,747	14.2	67.9	50.9	86.9	12.5	0.7	
3. Flouring and grist mill products	1,016,859	9.0	35.2	42.1	52.5	44.4	3.1	
4. Cotton goods.....	811,347	7.2	74.5	840.4	65.5	31.1	3.4	
5. Paper & wood pulp..	764,847	6.8	156.9	1,002.4	33.5	66.0	0.6	
6. Woolen goods	139,645	1.24	14.0	136.4	59.4	37.5	3.1	
7. Worsted goods.....	97,383	0.86	72.3	526.4	75.2	21.0	3.8	
8. Agricultural impl....	77,189	0.68	53.2	129.7	79.2	8.8	12.0	
9. Silk and silk goods...	61,395	0.54	107.2	129.3	74.7	10.9	14.3	
10. Hosiery & knit gds..	58,087	0.51	68.2	69.8	68.3	25.5	6.2	
11. Boots and shoes, factory products	51,073	0.51	66.4	49.7	68.2	4.7	27.2	
12. All other industries.	4,937,962	43.72	105.1	46.3	83.0	4.2	12.8	
All industries	11,300,081	100.0	
Average	89.8	66.7	77.4	15.3	7.4	

surplus power. Mr. Kittredge in his census report on by-products quotes even a higher figure, \$1.25 per ton pig of saving by using gas instead of steam power. The United States in 1903 produced 18,000,000 tons of pig iron (1904 report of American Iron and Steel Association). The money value of surplus gas, therefore, presumably ranges somewhere between \$10,000,000 and \$20,000,000 per year, which averages 2.5 per cent of the capital employed in the industry. These figures will naturally be received with skepticism, but it is only necessary to calculate a specific case to appreciate their approximate correctness.

Blast-furnace gas is found by experience to make an excellent power gas, as it is not "snappy," therefore permitting of comparatively high compression and consequently high efficiency. The difficulties in cleaning have apparently been overcome and several American engine builders are prepared to meet the demand for heavy duty engines of several thousand horsepower capacity. Every iron and steel works operation blast-furnace establishment should thus become a producer of energy for its own and outside consumption instead of an augments of the smoke nuisance.

The coke industry affords an important field for gas power. Coke by itself represents about 75 per cent of the best value of the coal coked. The remaining 25 per cent in the case of the ordinary bee-hive oven is discharged into the atmosphere in the form of products of combustion. The gaseous distillate is practically the same as ordinary retort coal-gas and as such forms a most excellent fuel for power purposes. The magnitude of this waste is shown by the fact that out of a total of over 25,000,000 tons of coke made (U. S. Geological Report, 1904) in 1903, 23,500,000, 92.6 per cent, was produced in common bee-hive ovens, the remainder, 7.4 per cent, being made by the by-product processes. One ton of suitable coal will produce from 9,000 to 10,000 cubic feet of gas, averaging at least 600 B. T. U. per cubic foot. This waste is therefore equivalent to 4,200,000 long tons of coal per year.

By-product coke processes apparently offer the only remedy for this waste and have gained a substantial foothold in this

country, producing nearly 2,000,000 tons of coke per annum (1903). In Great Britain 10 per cent of the 1902 coke production was from by-product ovens. In Germany by-product coke is reported to have reached, in 1900, the astonishing total of 40 per cent of the total coke production.

In by-product plants, from 55 to 70 per cent of the gas is used for supplying heat to the ovens; the remaining 45 to 30 per cent is available for illuminating or power purposes. This surplus is drawn off during the first half of a regular run and contains the richer distillates, averaging from about 575 to 675 B. T. U. calorific value. From every ton of coal coked there remains, therefore, about 3,600 cubic feet of rich gas, equivalent to 166 horsepower hours available per ton coked. As the usual coking run is 32 hours, the power available is therefore 5.2 continuous H. P. per ton. Upon this basis, if the total coke production was from by-product ovens, the net power available would at present be over 30,000,000 continuous H. P.

The success with which coke gas has been applied for power purposes in Europe is indicated by the following extract showing a partial list of power equipments in operation or building during 1904:

No. engines in service.....	40
Total capacity of engines....	12,684 H. P.
Av'ge capacity per engine....	317 "
Type—4-cycle—total cap'cy.	2,265 "
Type—2-cycle—total cap'cy.	10,419 "

Service.—Operating by-product plant, blast-furnace blowing engine, coal washing, steel works machinery, electric mining system and electricity supply.

The majority of prominent European gas engine builders are well represented, and the size of engines leaves little doubt as to the commercial success of the arrangement.

Surplus gas from by-product coke ovens has already been applied to commercial distribution for domestic and manufacturing purposes. The limitations in this respect appear to be identical with those involved in the long-distance distribution of natural gas, except that higher compression is necessary to deliver the same quantity of heat, owing to the lesser calorific value of the gas.

The distribution of gas over a large territory is in many ways closely analogous to the transmission and distribution of electric power, with one important difference—the efficiency of the compressor. Compression of gas to high pressure is admittedly inefficient, while electric current may be raised to any convenient potential with a loss of but 2 or 3 per cent. Hence this limitation of gas distribution may be largely removed through the employment of high-tension electricity, which has so effectively extended the commercial radius of power distribution from tens to hundreds of miles.

It is thus apparent that our coke-producing fields should become power-producing fields as well. Electric generating stations should be established near the center of adjacent groups of ovens, serving electric light and railways to the surrounding towns lying within the commercial distribution radius. In addition to the electric service, a portion of the gas might also be distributed for limited distances for commercial and domestic use.

By reason of the large amount of power available and its low cost of generation, industries should be attracted to locate within the coke supply districts in some such manner as those in the vicinity of Niagara and the Soo. The cost of power development in the coke regions is scarcely comparable to that of low head hydraulic development, and the undertaking should, therefore, prove the more profitable.

The destruction of city refuse is not a new development, as it is practiced widely abroad, and to a limited extent in America, notably in New York City, where partial reclamation of by-products is also accomplished. But the use of the waste heat from the process has received little attention here. A number of British municipal destructor plants generate steam for electricity supply. At Glasgow the steam raised is equivalent to nearly 9,000 H. P. per ten-hour working day. A recent report from Burnley, England, shows an average evaporation of 1.58 pounds of water per pound of refuse over 13 weeks' regular operation. Another from Nelson gives the average evaporation as 1.8 pound, calorific value 4,442 B. T. U. per pound refuse. At Zurich, Switzerland, the Brown-Boveri Company is erecting a destructor electric plant, using Parsons steam turbines for supplying the town with electricity.

British town refuse, although subject to wide variations, has an average calorific value of about 2,500 B. T. U. per pound. The average duty of the British plant is usually 20 to 40 kw. hours per ton burned under ordinary working conditions, 50 to 60 being occasionally obtained. The average duty of 17 combined destructor-electric plants in London and provinces during 12 months' operation was 24.5 kw. hours per ton of refuse burned, or 91.4 pounds per kw. hour. Many of these have been recently established, and the electric load is therefore small. If all of the refuse had been utilized the plant duty would have averaged 42.4 pounds per kw. hour, or 52.8 pounds of refuse per kw. hour.

London garbage is stated to aggregate 1,250,000 tons annually. Assuming a very possible duty of 50 pounds of refuse per kw. hour, the power equivalent of this refuse is 56,000,000 kw. hours annually, or 6,400 kw. continuous generating capacity.

If domestic refuse has proven suitable for steam raising, it is but a step to eliminate the steam and utilize the thermal potential of the liberated gases directly in the cylinders of internal-combustion engines. Efficient cleaning apparatus is available and present forms of destructor cells require but little modification to convert them into efficient gas producers.

It would obviously be idle to predict the universal possibilities of such a method of reclaiming city refuse; it is sufficient to reflect upon the present magnitude of this waste of the cheapest of fuels.

In the rich vapors given off during the refining of crude petroleum exists a convenient and valuable source of power that has recently been turned to useful account by a large American refinery, the Atlantic Refining Company, of Philadelphia. The oil gas is exceedingly rich, approximately 1,500 B. T. U. per cubic foot, and is based directly in gas engines for producing the power necessary to light and serve the establishment.

A mooted question in gas works operation is that of power for auxiliaries. It is understood to be the subject of a special report during this session, and will therefore be only touched upon here to the extent of a suggestion.

The advantages of gas-driven auxiliaries are well known, but the source of power is less certain. Outside the regular gas sup-

plied to customers, a possible source lies in the "blow gas" of water-gas plants. This, however, the author is informed, should be largely unavailable with proper manipulation of the gas-making process, by reason of the small amount of combustible remaining. Producer gas is the suggested alternative, using coke as fuel.

Producer gas, however, immediately suggests far greater possibilities than simply supplying the few horsepower necessary for gas works operation. The power load of a gas or electric distributing system, unless confined to periods during which the output for lighting is small, becomes more or less of a burden, depending upon how heavily the system is loaded during peaks. Over-lapping of loads is manifestly undesirable, and in many cases impairs the efficiency of service. Electric distribution from an auxiliary producer gas electric plant operated by the gas works presents an opportunity of remedying this evil. The lesser investment in an electricity distributing system, greater ease of extension and higher efficiency enhances this opportunity.

In towns where the business is not sufficient for the support of independent competing companies, the auxiliary gas-electric system may readily be developed to cover the entire demand for electric street and incandescent lighting and power. The low price at which electric current may be sold constitutes a powerful inducement toward securing the desired business. By proper adjustment of rates, the heating, gas lighting, electric lighting and power loads may

be developed independently, as may be desired in the most advantageous proportion, avoiding the mutual interference which would otherwise occur. Coke or coal, according to prevailing prices, might, of course, be utilized in the producer plant.

Outside of the comparatively localized application of gas power above considered is its general use in electric lighting and railway power plants. In 1902 there were 3,620 central lighting and power stations in this country, employing 1,800,000 H. P. in prime movers, approximately three-fourths of which was steam power, the remainder hydraulic. No representation was given to the gas engine, although it is certain that a number of American central stations are operating exclusively upon gas power.

In 1902 there were 1,400,000 H. P. of prime movers in electric railway service, 96 per cent of which was steam power, 3.8 per cent hydraulic and under 1 per cent gas power. Of the total steam power, 67 per cent was represented by engines above 500 H. P. and 44.3 per cent by engines above 1,000 H. P. capacity. But five companies reported the use of gas engines, these ranging from 75 to 600 H. P. As a number of companies rent power, the gas power representation is less than it should be by at least three or four companies, to the author's own knowledge. Here is a wide field for the high-power gas engine, and the example set by the Warren & Jamestown Railway, which is building a single-phase gas-power interurban road, will, it is hoped, be emulated by American railway systems.

A GAS ENGINE WRINKLE.

"About the hardest case of trouble with a gas engine that I ever had to locate," said a gas engine expert recently, "was on an engine competing with our own. The people who had the engine said it would start all right and run nicely for about fifteen minutes or a half hour, and then it would shut down from apparently no reason and without any one having touched it. After trying in vain to start it, it would possibly start up again, but would never run more than about the time mentioned. I worked on it a long time before I found the cause of the trouble.

"In bringing the gasoline supply pipe from the storage tank to the engine, the erector had in one place allowed the pipe

to come within an inch or two of the exhaust pipe, and not very far from the engine. The result was that when the engine had run a short time the exhaust pipe got hot enough to heat up the supply pipe where the two came close together. After a short run this would sufficiently vaporize the gasoline in the pipe to prevent the gasoline pump from getting fuel up to the engine.

"Of course, it was a very simple thing when once it was discovered, but it took a lot of time and hard thinking to find it."

Judging by reports from various sources, Liverpool is making unusual efforts to try the relative merits of various freight motor trucks in competition with railroads.

ANSWERS TO INQUIRIES

It is our purpose to answer in this column inquiries of general interest which relate to the gas engine or its accessories. The questions will be answered in these columns only, and we reserve the privilege of refusing to answer any question which is not, in our judgment, of interest to the subscribers of THE GAS ENGINE.

All matter intended for this department should be addressed to The Editor of THE GAS ENGINE, Blymyer Building, Cincinnati, Ohio. The name and address of the sender must accompany the inquiry in all cases as evidence of good faith. The initials only of the sender will be published, together with the postoffice and state.

Write on one side of the paper only, and make all sketches and drawings on a separate sheet. Mark each sheet with the name and the address of the sender.

(a) I have a four-cycle 4 x 4-inch auto engine which I intend to place in an 18-foot launch, speed 200 to 1,600 r.p.m., 4 I. H. P. What should be the weight of the rim of flywheel 16 inches in diameter at center of gravity of rim? (b) From formula No. 22, page 163, of the Handbook using the mean speed $(200 + 1,600)$ of 900 r.p.m., weight equals

$$\frac{4 \times 111600000000}{16^2 \times 900^3 \times .15} = 47.8 \text{ lbs.}$$

Isn't this too light? (c) Did I use the proper number of r.p.m.? (d) Would it be advisable to use drawn steel tubing $\frac{1}{4}$ inch or 5-16 inch thick, $2\frac{1}{2}$ inches or 3 inches in diameter for the cylinder of a four-cycle motor? (e) Would cast iron pistons work well in such cylinders? Could they be successfully cooled by using $\frac{1}{8}$ or $\frac{1}{4}$ -inch copper or steel pins screwed into the sides, and if so, how deep and how far apart should I drill the holes.—P. J. C., Dobbs Ferry, N.Y.

(a) We would suggest a 90 or 100-lb. flywheel for this diameter. (b-c) The trouble is due to taking too high an r.p.m. figure. Your flywheel at about 800 r.p.m. for a launch or automobile engine, using the H. P. that can be given at that speed. (d) Drawn steel tubing is not satisfactory for gas engine cylinders, for the reason that it will cut. (e) We do not see the advantage of an air-cooled engine in a launch,

as you always have the water near by. In case you used an air-cooled engine you would have to use a fan to cool it successfully. If pins are used they should be put as close together as it is possible to place them.

What would be the H. P. of a four-cycle marine gasoline engine 4-inch bore, 5-inch stroke, running at 650 r.p.m. (b) What diameter and what weight flywheel would it be practical to use and get good results? (c) What are "heat units," and how are they figured out?—C. B. P., Delray, Mich.

(a) Three H. P. (b) Fifteen inches diameter. About 120 lbs. (c) A heat unit is the quantity of heat required to raise a pound of water one degree F., and is usually known as the British Thermal Unit. To obtain the number of heat units in a certain gas, the gas is made to heat a known quantity of water, and this weight, multiplied by the rise of temperature in degrees F., is the number of B. T. U. given off by that amount of gas.

Of two engines having the same H. P., one, a large bore, low-compression, low-speed engine, the other a small-bore, high-compression, high-speed engine, in which will there be the greatest wear in the bottom of the cylinder? (b) I am building an engine, and, wishing to eliminate as much of the wear in the bottom of the cylinder as possible, which is the best, a light piston or an exceptionally long rod? (c) What is the proper length for the rod in a four-cycle 9 x 18-inch engine, with 90 lbs. compression and a speed of 260 r.p.m.? (d) What are the advantages of injecting water with the fuel, into a gas engine cylinder, and what effect has it on the lubrication—F. H., El Monte, Cal.

(a) The wear is proportional to the speed and the pressure when the surface is the same. The pressure on the cylinder wall should generally be limited to about 20 lbs. per square inch of projected area. It should be noted that the pressure is not that on the cylinder head, but must be figured in graphically from the greatest angle of the connecting rod. Space will not permit

a full treatment of this subject in these columns. It will be found in several works on gas engine design. (b) The weight of the pistons has very little to do with the wear, as it is but a small fraction of the pressure. Light pistons are necessary to high-speed engines. A rod $2\frac{1}{2}$ to 3 times the stroke is the usual practice in stationary engines. (c) We should recommend a rod 45 inches long for these conditions. (d) Experiments have shown that by injecting water into the cylinder the economy is increased; in other words, the fuel consumption is cut down. We do not know of any deleterious effect upon the lubrication.

(a) What is the pressure most suitable to use in a compression-cycle engine using a low-grade oil heavier than kerosene? (b) What is the formula for calculating the volume of the compression space? (c) What method is used in timing the engine with hot bulb?—J. W. U., Carpinteria, Cal.

(a) Seventy-five to 80 per square inch. In other words, as heavy a compression as can be used without premature ignition (b) We have not space to discuss this formula in these columns. If you will refer to Chap. XIV of the Gas Engine Handbook you will find it thoroughly discussed. (c) Customarily timing with the hot tube or hot bulb is regulated by the length of the bulb and the distance of the incandescent portion from the mouth of the bulb where it opens into the cylinder. The longer ignition tube with the incandescent portion near the cylinder gives early ignition. A short tube gives late ignition. The time of ignition will be when the new mixture has sufficient compression to drive the dead gas in the tube back of the hot spot.

How do you form an emulsion of water and gas engine cylinder oil, emulsion to be permanent and used with a small pump. (b) What is the utility of the yoke in place of the connecting rod on high-speed automobile engines?—R. M., New York, N. Y.

(a) Emulsion with oil is usually made with lime water, by shaking up the oil with the lime water. (b) We would not recommend the use of a yoke for a high-speed automobile engine; we believe the connecting rod is much better.

(a) What would you consider the proper dimensions for a two-piston, two-cycle en-

gine, 4-inch bore and 4-inch stroke, charged from a separate pump? (b) What should be the diameter of the crank shaft and the diameter of the crank pin? (c) What should be the length of the compression space for this engine?—J. D. S., South Bend, Ind.

(a) Not knowing the speed of your engine, we would not know what area to give for the ports. For speeds between 600 and 1,000 we should make the width of the inlet port $\frac{1}{2}$ inch, and the width of the exhaust port $\frac{3}{4}$ inch, both in the direction of piston travel. The length of the piston port will depend upon the speed of the engine. (b) Make the diameter of the crank shaft according to the way it is connected up. For one piston $1\frac{1}{4}$ inch would be right for the crank shaft and $1\frac{3}{8}$ inch for the crank pin. (c) The length of the compression space; that is, the distance between the two pistons when at the end of their stroke, should be $2\frac{3}{8}$ inches. We suggest that you let the inlet port be uncovered by one piston and the exhaust port be uncovered by the other. You will then need no deflecting plate.

I am designing a trading vessel, 60 feet long, 12 feet beam, 8 feet depth of hold, full model, with good lines fore and aft, for service around the Gulf coast. The engine will be a four-cylinder upright, fitted for crude (Beaumont) oil; size of cylinders, 8 x 14 inches. This stroke is rather long for marine use, but I have patterns for this size, and my experience is that a more reliable service, with much less repairs, is obtained with a longer stroke and less revolutions than with the short stroke, strenuous high-speed motors. The above refers, of course, to where you have the room to install the longer stroke. Above engine will be fitted with governor, and speeded to 300 r.p.m. (a) What size screw with $1\frac{1}{2}$ pitch ought this engine to handle at that speed, with boat drawing $4\frac{1}{2}$ feet? (b) Would you advise two or three blades, and would you consider $1\frac{1}{2}$ pitch about right? (c) With a screw of the right diameter and pitch, what speed can I expect with this vessel? (d) Do you consider 90 lbs. compression for crude oil the best practice? (e) Will above engine work up to 60 H. P. at 300 r.p.m., and is a 1,000-lb. flywheel, 30 to 36 inches diameter sufficient?—H. H. M., Mt. Carmel, Ill.

Not knowing the lines of the boat we can

figure the wheel only approximately, but we believe a wheel $5\frac{1}{2}$ feet in diameter and $6\frac{1}{2}$ pitch would be all right. It is probable that you would have to try several wheels before you get one that will suit your boat. (b) We believe three or four blades would be better for a cargo vessel. (c) We judge about 12 miles an hour. We believe that 90 lbs. is a little high for this, and 75 to 80 lbs. would be about as high as you could work. It is best to work as high as the oil will stand, or until you just avoid premature ignition. (e) The engine should give 60 H. P., and will possibly give 65 H. P. at the rated speed, provided she is in good working condition. A 600-lb. flywheel with a mean diameter of 30 inches will be ample for this engine.

W. O. B., Charleston, S. C., sends us an inquiry and sketch describing trouble he has with a peculiar igniter on a two-cycle engine, of which he sends us a sketch. The igniter is of the piston operated variety, the points being separated with the deflecting plate, which strikes the end of the movable electrode. He says of this engine: "I can start the engine up and it will jump right off and run for about half an hour, starting to slow down, and sometimes stops and gives me trouble in the middle of the river. I do not think it could be the gasoline, or it would not start so promptly. I notice the water jacket gets so hot I can just touch it. I also think my trouble is due to the igniter, as I notice when I examine the points that they are broken off. I use $\frac{1}{8}$ -inch stove rivets with 1-16-inch silver brazed on the head. After I put in new rivets the engine will run again for half an hour. She races like the mischief. Will you kindly advise me what is the trouble, and whether you think I can make the engine better by operating the igniter from the pump?"

In the first place, the engine gets hot either because the piston is too tight or the circulating pump is not operating properly. For an engine of this size ($2\frac{1}{2}$ H. P.) the overflow will be a stream about as big as the forefinger, and the water should never be boiling. Stove rivets are very poor things for igniter points, for the reason that they are soft and will hammer down. Platinum is used a great deal, but large copper rivets, say $\frac{1}{4}$ inch diameter, will answer is your igniter does not hammer too hard. We know that this is soft, but it has been used successfully. We believe you can make the ig-

niter operate better by working it from the outside by means of the pump eccentric.

A friend of mine and I had a dispute. He says that if you put a 3 H. P. engine in a 20-foot boat with a 15-inch wheel, and then put the same outfit in a 35-foot boat, then the engine will still go at the same speed, but the boat would go slower, and there would be no more wear and tear on the running parts. He also says that a 12-H. P. engine with 24-inch wheel which is run in a 35-foot boat will run the same speed when tied to the wharf as when running wide open on the river. I would like to have your opinion on this matter.—W. O. B., Charleston, S. C.

Under the same conditions the engine would not speed up with a bigger boat, provided she was on the same lines as the small one. If the resistance was the same on both boats as might be obtained by making the smaller boat with very bluff lines, and the larger boat with very fine lines, the engine would make the same speed and would drive the larger boat at the same speed as the smaller boat. As to running the engine at the same speed with the boat tied up at the wharf, the engine will run slower, provided the screw propeller is the same. Watch your friend, in case he has a reversible propeller, that he does not put it at part pitch, or, in case he has a clutch, that he does not slip the clutch. Under the same conditions we are quite sure you will find the engine will run with less revolutions tied up at the wharf. Try it yourself first and see.

AUTOMOBILES FOR EUROPE.

I believe the time is at hand when American manufacturers of automobiles and motor boats will find a market in Europe, and it may be well for them to give the subject serious attention. For some time past it has been generally supposed that it would be impossible for Americans to compete with German and French manufacturers. but I think there are many machines of American make that will now find a market on the continent. In Lucerne I have noticed a few machines of American make, and the owners express themselves as being pleased with them. The small "runabout," so extensively used in the United States, would, I believe, find a market here. The cheapness, durability and strength of our machines will bring them into consideration.

BOOK REVIEWS.

"Gas Engine Design," by Charles Edward Lucke, Ph.D., Mechanical Engineering Department, Columbia University, 8vo., cloth, 254 pages, 6 x 9, 145 diagrams and figures, numerous tables. Price: \$3.00.

A man who claims to know considerable about gas engines, and who is engaged in their manufacture, recently said to the writer: "Gas engine design is not accurate. You can build a steam engine and tell before you build it just what it will do. But my experience with gas engines is that you can't tell a thing about them till you get one built and run it." Another man, a mechanical engineer, but not a gas engine specialist, recently said: "You can't possibly get everything you need in a book on design. The things you want most, are left out."

This book by Dr. Lucke on "Gas Engine Design" has brought the above-mentioned conversations to the reviewer's mind. The gas engine manufacturer said that the action of a gas engine could not be determined before the engine was built. Dr. Lucke's book is remarkable, in that it shows how many actions of a gas engine may be foretold with reasonable accuracy. The mechanical engineer, in his conversation, complained of not finding many points of instruction in books. Dr. Lucke's book covers an exceedingly large number of features of gas engine design which we have not found elsewhere. After reading this book one is impressed with the fact that gas engine design is an exact science and that the action of an engine may be confidently predicted by the expert designer.

The work is divided into three parts. The first, covering 60 pages, relates to the power, efficiency and economy of the gas engine and gives the material necessary to decide on the piston displacement.

The second part, covering 86 pages, gives data for determining the stresses in parts, and the number and arrangement of cylinders necessary for balance or turning effort to meet any given specifications. The indicator diagrams, with their accompanying descriptions, are of exceptional interest and value to the student in this subject.

The third part, 103 pages, relates entirely to the dimensions of the various parts of the gas engine, and the stresses to which each part is subjected.

The results given apply to engines from the smallest up to the largest units and for all classes of service.

The three parts of the book are subdivided by paragraph headings, which constitute, with the table of contents and index, a very convenient method for reference purposes.

Gas Engines and Producer Gas Plants—By R. E. Mathot, M.E., translated from the French by Waldemar B. Kaempffert. Cloth, illustrated, 314 pp., 5½ x 9. \$2.50.

The sub-title to this work says that it is "a treatise setting forth the principles of gas engines and producer design, the selection and installation of an engine, conditions of perfect operation, producer gas engines and their possibilities, the care of gas engines and producer gas plants, with a chapter on volatile hydrocarbon and oil engines."

The author of the work is a well-known Belgian authority on the subject of gas engines and gas producers, and has written much for the technical press on these subjects. The present work is remarkable for the detail with which it goes into the subjects considered. For example, in discussing the vibrations and noises of gas engines and accessories, attention is called to the fact that even the shape and size of the engine room may affect the vibrations. "In large single-acting gas engines," says the author, "a considerable displacement of air is thus produced (i. e., by the reciprocating motion of the piston). In the case of a 40 H. P. engine having a cylinder diameter and piston stroke respectively of 13¾ inches and 21 3-5 inches, it is evident that at each stroke the piston will displace about two cubic feet of air, the effect of which will be doubled when it is considered that on the forward stroke back pressure is created and on the return stroke suction is produced.

"The air motion caused by the engine is the more readily felt as the engine room is smaller. If the room, for example, be 9x7 5/8 feet, the volume will be 1,080 cubic feet.

From this it follows that the two cubic feet of air in the case supposed will be alternately displaced six times each second, which means the displacement of 12 cubic feet at short intervals, with an average speed of 550 feet per minute. Such vibrations transmitted to halls or neighboring rooms are due entirely to the displacement of the air."

The first 152 pages of the book are de-

voted to the gas engine itself, and by this is meant strictly the "gas" engine, as no liquid fuel engines are touched upon in the work, except in one chapter at the end of the book. About 100 pages relate to producer gas engines, pressure and suction gas producers.

The selection of an engine, tests and various other matters are considered in the last 25 pages.

THE PAST, PRESENT AND FUTURE OF MARINE PROPULSION.

To the novice seeking power for his launch or yacht, the mention of a gasoline engine brings from his lips a recital of the dangers and trials which he has either witnessed or heard of, as happening to a host of his friends and acquaintances, and often considerable trouble is had in winning him over to the adoption of this wonderfully efficient and much abused servant of the marine world. It is only within a very short time that engines of this type have proven "as reliable as steam" and there is still room for improvement. The drawbacks of a steam engine, with its hot and dirty boiler, government inspection and licensed crew, with all their attendant advantages, have forced the development of the gas engine more than has anything else.

As soon as the gas engine showed its adaptability to this work, there was a rush from every quarter to build marine motors by people who had little experience in building such engines. Some had made a success of the stationary gas engine, and used the same general lines for their marine type, the result being an engine of great weight and tremendous vibration, the manufacturer telling his customers that weight was absolutely necessary in a gas engine, if the engine was to have long life and durability.

To such an extent has this heresy been drummed into the heads of the public that it is the hardest task for the well-informed engineer to convince them of the contrary. Steam engines had to pass through the same experiences in development, and today we have in that field light, graceful and powerful engines that are doing the hardest kind of work. The day of the heavy, gaudily painted casting, with a hole bored in it for a cylinder, and with little or no "design" in its construction, is about over,

and careful engineering calculations will in the future govern the manufacture and application of marine motors. So much for the Past.

For the Present: A new element has forced its way into the marine field, applying engines taken from automobiles and calling the combination an Auto-boat, a name which signifies nothing but which exhibits the ignorance of its sponsors. Such a name is meaningless and the engines are so light that they go to pieces in a very short time. Turning a propeller wheel is hard, heart-breaking service. It is one continued grind, not intermittent, as in the automobile, and in order to make a success the builder must be a thoroughly equipped man in his knowledge of marine propulsion, both to hull, design and construction, and the placing therein of the proper engine and propeller wheel in order to get the best and most economical result in the harmonious working out of his problems.

As to the Future: There is a vast field opening up in the popular and health-giving recreation of motor-boating, the season just closed having given it a wonderful impetus. The auto-boat of today has awakened a wide interest, but the speed or racing launch of the future, to use a legitimate and proper nautical term, will make it even more popular.

"Why is a marine engine different from any other, and in what respects?" is the question asked, and it is the purpose of this article to try to give light to those whose past experience has been confined to the old design of a heavy closed crank case, castiron, water-jacketed engine, with heavy cumbersome and crude firing and valve mechanism.

Where "Splash" lubrication for the con-

necting rods and cranks is used, an oil-tight base is a necessity; but this lubrication is poor at its best, as more or less grit will get into the bearings, and the oil is churned over and over again, until a thick, black, gritty mass accumulates which cuts out bearings very fast and is a nasty mess to get rid of. An engine for yachts should be as beautiful as the handsomest steam engine built for that purpose. The owner should be able to take his friends to the engine room with as much pride as he has in any other part of his little floating palace.

The cylinder should be mounted on light, graceful steel columns, braced to prevent lateral motion, and a light copper or aluminum casing, easily removed, should be put on the crank case to keep the oil from flying. This gives plenty of light and room for making all necessary adjustments. There should be an oil cup on each connecting rod, with oil duct leading directly to crank pin, through the brass. Connecting rods should be either drop-forged steel or hand-forged and milled out to an I beam section. All bearings should be large, easily adjusted for wear, and should have an oil pipe leading to each one from a good forced, sight-feed multiple oiler.

In oiling pistons, anything over five inches in diameter should have oiling tubes *on each side*, and with a "forced feed" lubrication system which is entirely governed by the speed of the engine, the rate of lubrication is automatically proportioned to the speed at which the engine is running, and there is no possibility of back pressure in the oil cups, as is so often the case with the gravity oilers in general use. The writer has known of many cases where oil cups, instead of oiling the engine, the engine oils the cups, and actually fills them by the back pressure, especially on the aftermost cylinder.

A marine engine must be as compact and light in weight (compatible with strength) as possible, and should be so designed that any part can be adjusted, taken out or renewed without disturbing anything else. For the quarters in which engines of this type are placed are oftentimes cramped and dark, and accessibility, after reliability, is a prime necessity. When these points are given proper consideration in the design and construction of marine engines far greater success and pleasure will attend their use than has been experienced in the past.

This fact has but very recently been impressed upon the writer in two instances. The first was when a gentleman gave him a commission to design and build a new propeller wheel for his yacht in place of one that had become broken. When the old wheel was received it was found that the makers of the engine had bored the wheel with a taper hole, *back end first*, and the party had been using the propeller, *going ahead on the back up face*. The other case is where a circular was received from a prominent builder of engines on which were two cuts, showing what they called a right and left hand engine, and on these cuts they said of one: "This is a *left hand engine* and requires a *right hand propeller wheel*;" and on the other: "This is a *right hand engine* and requires a *left hand propeller*."

The writer has often heard of left hand monkey wrenches, but this is the first instance in which he ever heard tell of a left-handed screw driver for the purpose of putting in a right-handed screw; and this is only illustrative of the general lack of information upon the part of not a few who have been turning out marine engines.

We often hear of 35 and 40 H.P. engines weighing less than 400 pounds; but such horsepower is a horsepower figured on of a propeller wheel that would enable the engine to turn up a given number of revolutions, producing enormous slip, waste of energy and fuel, and wear and tear of the engine; whereas, a wheel to suit the hull, using the same engine, would cut the horsepower down to two-thirds or less of what was claimed for it, and yet drive the hull just as fast with less fuel and wear and tear than at the higher revolutions.

There is no reason why a man should not have as much confidence in purchasing a marine gasoline engine as he would in buying a steam engine, and the business is sure to go to those concerns who, through technical training and engineering ability, will be able to turn out an engine that will meet all these requirements.

This article is not written for the purpose of harshly criticising any engine or its builder, but with the sole desire to help along the improvement now going on in this field, and in order that those who buy and operate marine motors may do so with the least amount of exertion or trouble and the greatest amount of pleasure.—*The Motor Boat*.

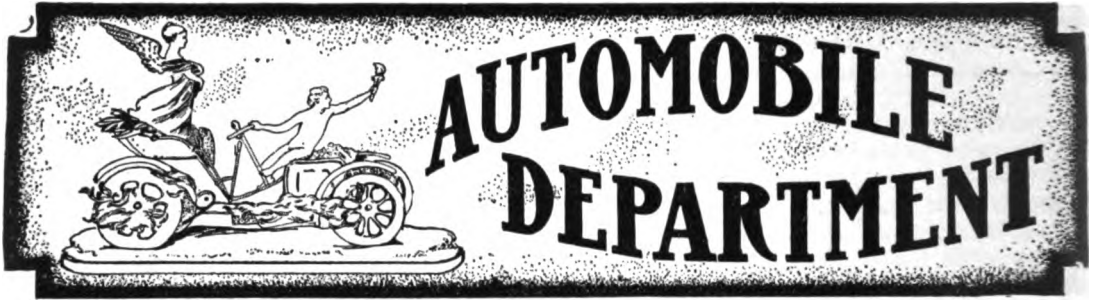

One of our contemporaries suggests the establishing, by one of the national automobile organizations, of a standard brake horse-power test, with official licensed testers in various parts of the country, who would make the standard test of any engine "for a specified fee," and issue a certificate to the manufacturer. This suggestion was made in view of the fact that engines of various cylinder dimensions are rated at various powers, some of them so much higher than others that it would appear to the disinterested observer that either the engine was overrated or else the manufacturer was able by means of his special design and construction to secure much more power than his competitors. We, however, fail to see where the system proposed would help matters.

It is admitted that there are many things besides the bore and stroke of an engine which determine the brake horse-power of an engine. Any operator can readily discover this for himself by allowing his engine to get out of adjustment, by allowing a compression to escape past the piston rings, etc. And the power given by one engine of any make is not necessarily a criterion to judge of the power developed by other engines of the same make. Therefore the test of the "official tester" would be a record for the test of but one engine, and unless the tester personally tested every engine sent out, his record would have no more value than the statement and record of the manufacturer himself. And why should the public be expected to accept as any more truthful the records of an official tester (who would be paid by the manufacturer) than the records of the manufacturer, who vouches for them himself?

We believe that in automobile engines the power of engines, as judged by the public from the manufacturer's statement, must be based upon the same circumstances as has

the power of stationary engines and steam engines. The manufacturers must be willing to guarantee a certain brake horse-power. Their engines must develop, if anything, more than this guaranteed power. Occasionally the engines will be tested by the purchasers, and the manufacturer's rating will be vouchsafed. If, on proper tests by the public, the engines do not come up to power, the manufacturer suffers accordingly. Of course, there is a chance that these tests by the public will not be accurate, and the manufacturers of stationary engines have occasionally suffered from an unjust test. But it has come to be the accepted judgment among those familiar with stationary engines that certain makes always develop an excess of power over that guaranteed. Other makes are well known as covering little, if any, above the guarantee. But no amount of "official testing," either on one or all the makers' engines, could change the reputation gained in these cases by various companies. The credence given their statements as to power developed is dependent on the general truthful standing of the individual companies, together with the evidence secured in the occasional tests, the results of which are promulgated by the maker's salesmen or those of his competitors, depending on whether the evidence was favorable or not.

The automobile engine maker's record of tests of his engines must be dependent on the character of the individual company and the evidence of the nature just referred to.

With the Selden patent claiming to cover all gasoline automobiles, as at present constructed, there was enough trouble in sight. Now it is claimed that there is a "basic" patent covering electrical ignition of gas engines, which will be even more of a trouble maker than the Selden patent.

<p style="text-align: center;">THE ULTIMATE LIMIT OF SPEED IN GAS ENGINES.</p>

In view of the rapid increase in piston speed and speed of revolutions, which has marked the development of the automobile motor, and the impending increase of nearly or quite the same amount in gasoline marine engines, the question must frequently be discussed, what is the ultimate limit of speed of these motors? By ultimate limit of speed here is not meant the very highest speed at which any motor can possibly run, but rather the limit imposed by engineering conditions for steady and continuous running. As it is only in the above classes of motors (and, one might add, in flying machine motors) that the highest possible speed seems likely to be sought, stationary motors may here be left out of consideration.

If one were to canvass the makers of automobiles and launch motors, especially perhaps the latter, and were to ask each for his reasons for not aiming at a higher speed than that specified in his catalogue, an interesting variety of statements would undoubtedly be brought forth. One builder, for example, would say that any motor (including his own) would be shaken to pieces by a higher speed. Another would say that higher speed would not give more power, as the torque would fall off faster than the speed increased; and, if pressed for the reason why some other builder was able to run his motor faster, he would possibly reply with furtive hints about a pernicious practice of overrating horsepower. Still another would declare that the higher speed caused the piston to "run away from" the flame. Another might claim that faster running overheated everything, and induced premature ignition of the charge. Probably, however, the largest number would say that higher speed would make the engine wear out too fast in piston rings, cylinders or bearings, or all three, and that it is cheaper to run the engine slower and keep it longer.

Now, every one of the builders above supposed may have stated his own genuine experience; and yet, if his rated piston speeds were less than 1,000 feet per minute, there is fair reason for ques-

tioning if the obstacles he enumerated were really, in the last analysis, insuperable. In other words, he may have found his own limit, but certainly not the limit of speed, in an engineering sense. That this is the case is indicated by the large number of high-grade automobile motors whose "normal" piston speed—a rather indefinite term, it must be admitted—is fully 900 feet per minute, and which, when accelerated for racing, reach 1,200, 1,400 and even 1,500 feet per minute for hours and even days at a time.

It is freely admitted that the racing automobile requires a thorough overhauling after every long race, and the wearing parts of the motor generally get their share of attention on such occasions. The highest skill of the best engineers has not been able to change this fact, which simply means that our present ability to get the charge into and out of the cylinders, and to burn it, is ahead of our ability to make the motor "stand up." The real questions, then, are two: First, what is the highest speed in an engineering sense possible; and, when this highest speed has been determined, with what degree of closeness can the normal running speeds of commercial motors be brought up to it? It is, of course, evident that to whatever extent engineering skill is able to remove the practical obstacles in the way of high speeds, the high speed will be adopted in preference to the low, since it means a greater power output for the same, or nearly the same, first cost of engine and without increase of weight.

The above noted obstacles to high motor speed may be summarized as follows: (1) Vibration; (2) wear of piston, rings and bearings; (3) sluggish flame propagation and decreased torque; (4) overheating.

General wear and tear would no doubt be added as a fifth by many builders. It is, however, partly covered by (1), (2) and (4) above, but it will be referred to again in a later paragraph.

Although the first four factors are all serious enough to demand careful consideration, I do not think that "in the present state of the art" we are justified in

pronouncing any one of them, or even all together, sufficient to fix definitely the ultimate limit of speed. Vibration has already been amply demonstrated to be negligible in vertical motors of four or more cylinders, and, for moderate powers, not of serious moment even with three cylinders, except perhaps at certain critical speeds, when the vibration period of the motor happens to synchronize with that of the springs on which it is mounted, or the hull in which it is placed.

Ordinary wear is simply a question of bearing surfaces, proper materials and efficient lubrication. The last is indeed a difficult problem, and many builders, especially of the older type of launch motors, do not know how to lubricate effectively such parts as the crank and wrist pins. Still, the most efficient lubrication possible is by no means so common as it some day will be, at least where small engines are concerned. As to the piston and its rings, there is no way to save them from wear, but we may be very sure that if there were no other objections to high speed the purchaser would cheerfully pay the cost of new rings and an occasional new set of pistons, and of the necessary reboring of the cylinders, for the sake of getting, say 15 or 20 H. P., instead of getting 10, from a given size of engine.

Rapid flame propagation may be secured by an intense spark, and, if necessary, by igniting at two or more points within the cylinder. Even in the fastest automobile motors multiple ignition is hardly considered necessary today, and there is no immediate prospect of our being compelled to exhaust the possibilities in this direction. It is indeed necessary to use high compression, and a very good carbureter, if high piston speeds are aimed at, but each year sees carbureters improved, and high compression is no longer the bugbear of designers that it used to be. Compressions of 90 or 100 pounds per square inch are now used successfully in many automobile engines.

Overheating of the piston and of parts projecting into the combustion space is undoubtedly a frequent factor in restricting speed. Its influence, however, is rather indirect, since its effect is to necessitate a moderate compression, with which

high speed is hardly possible. It might be imagined that this factor would be a serious one, but it has not been found so, at least with cylinders up to 8 inches in bore, and it seems probable to me that piston diameters of 9 or 10 inches can successfully be used with high compression in gasoline engines, before recourse must be had to water injection or other devices to prevent premature ignition. One maker, at least, now casts his pistons with internal spines, designed to assist the dispersion of heat. I would prefer a suitable number of ribs to assist in conveying the heat to the piston walls; but, as a matter of fact, automobile motor pistons are made up to 5 or 6 inches in diameter, with very thin heads and scanty ribs, without trouble from overheating. The reason seems to be that, so long as the mean temperature of the gases in contact with the piston for the four strokes of the cycle does not exceed certain limits, the piston is not likely to heat to the point of igniting the gases spontaneously.

The problem of getting the fresh charge into, and the burned gases out of, the cylinder with sufficient rapidity is certainly one that calls for a good deal of ingenuity. Various makers have used multiple inlet valves, and in some cases also multiple exhaust valves, an illustration in point being the eight-cylinder engine of the "Arontio," built (the engine) by James Craig, Jr., of New York. Each cylinder of this engine has two inlet and two exhaust valves opening directly into the top of the cylinder head. The valves are operated from cams by bell cranks, and the exhaust valves are timed so that one opens a little before the other, thus relieving the pressure on the second valve. Some time the designers will find a limit to the size or number of their valves, but just where that limit will be found seems to be a question more of ingenuity than of mathematics, and to attempt now to place it seems hardly reasonable.

There is, nevertheless, a limit to engine speed, which, though it can not be rigidly fixed for all future time, is at least mathematically calculable for any given case, and can be approximately fixed for "the present state of the art." It depends on the weight of the reciprocating parts, and may be stated by saying that

the inertia force of these parts—piston, wrist pin and connecting rod—at the upper or outer end of their stroke must in no case be allowed to exceed the pressure due to compression in the cylinder. The importance of this inertia force at high speeds is well known to designers of high-speed steam engines, and perhaps to the majority also of the builders of high-speed gas engines, but I have not happened to see its influence graphically treated for the highest speeds at which a motor may safely be run.

At the beginning of any stroke, this force acts as a drag on the crank pin, and at the end of the stroke it tends to hasten it, and the intensity of this retarding or assisting force is proportional to the rate of change in the piston's velocity. That rate of change has its maximum values at the ends of the stroke, when the velocity itself is (for an instant) zero, and is zero when the connecting rod and the crank are at right angles. If the piston were connected to the crank pin by a Scotch yoke, this inertia would be the same at both ends of the stroke, but in consequence of the angularity of the connecting rod it is greater at that end of the stroke when the piston is farthest from the shaft.

If we were to neglect the angularity of the connecting rod, the inertia force at the ends of the stroke would be exactly equal to the centrifugal force which a body of the same weight as the reciprocating parts would exert if its mass were concentrated at the center of the crank pin. Taking the connecting rod into consideration, the formula actually to be used is the following:

$$F = F_0 \left(\cos. w + \frac{r}{l} \cos. 2 w \right),$$

in which

F = inertia force parallel to cylinder axis,
 F_0 = centrifugal force of same mass at center of crank-pin.

w = crank angle from top of stroke (a vertical engine being supposed),

r = crank radius,

l = connecting rod length, center to center.

If r be in inches.

$$F_0 = 0.0000285 W r N^2.$$

in which

W = weight of revolving parts in pounds.

N = revolutions per minute.

To get the total axial force on the crank pin, which is the thing desired, we must add the axial component of the centrifugal force of the large end of the rod. For this purpose the weight of the rod may be apportioned between its small and large ends by weighing it on two scales, with the center of each end supported and the rod lying horizontally. The small end will then be included with the reciprocating parts, and the large end will be treated as a revolving part. The axial movement of the centrifugal force of the large end will be the centrifugal force multiplied by the cosine of the crank angle w .

If the reader familiar with gas engines will take the weights of the piston, wrist pin and rod of any gas engine with which he is familiar, and will work out the above calculations for a piston speed of 1,000 feet per minute, he will perhaps be surprised to find how close the sum of these forces comes to equalling the total pressure of compression on the piston at the end of the compression stroke. Evidently the reason for not allowing these forces to exceed the compression is that, if they do, the connecting rod will be lifted till the slack of the crank pin bearing is taken up, and when the explosion comes it will drive the rod down again on the pin, producing a more or less destructive knock. Evidently, the looser the bearing the more violent will be the knock, and the sooner will the bearing succumb.

It might be supposed that if the compression were sufficient to hold the rod down on the crank pin at the extreme end of the stroke, it would be more than sufficient for this purpose during the whole compression stroke, but this is not the case if the terminal compression is high. The accompanying diagram shows a theoretical indicator card with a compression of 100 pounds gage, instantaneous ignition, and an explosion pressure of 300 pounds gage. It gives a mean effective pressure of about 78 pounds, which is by no means excessive, as a first-class automobile engine will give 80 to 90 pounds. It is used in preference to an actual indicator card, for the reason that the latter is nearly impossible to get at high speeds, and is subject to numerous variations according to the mixture and the time of ignition, which are elim-

inated in the ideal card. Practically the compression curve A B is the one of chief interest, and the actual curve would differ from the ideal only in beginning to rise above atmospheric pressure a little later in the compression stroke, and in rounding smoothly into the explosion curve, owing to the spark being advanced for high speed. At the critical point of

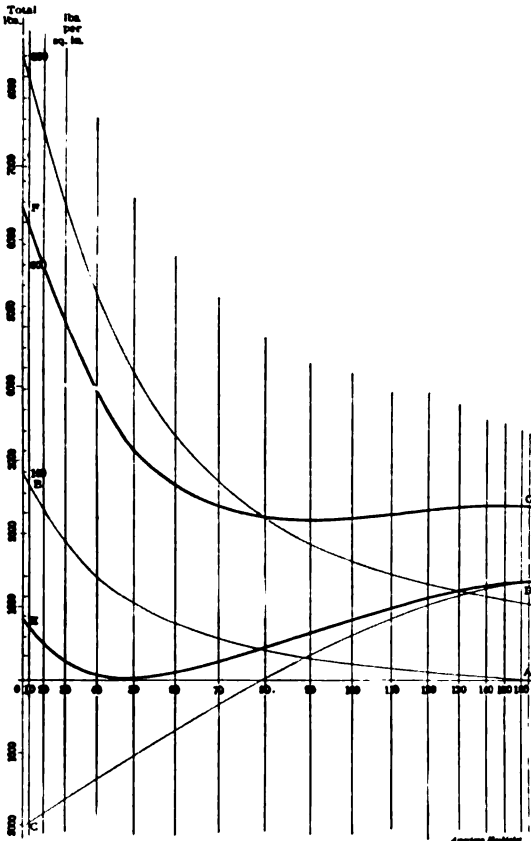

the curve, viz, about 45 to 50 degrees from the top center, the curve would be practically the same as drawn.

The curve C D is the inertia curve plotted for the several crank angles shown, the connecting rod being supposed to be four times the crank radius. But for the angularity of the connecting rod the 90-degree position would be midway horizontally, and C D would be a straight line. The engine is of 6-inch bore by 7-inch stroke, with the reciprocating parts weighing 13 pounds and the large end of the rod 4 pounds, and the speed is 1,000 r.p.m. Combining the two

curves A B and C D, we get curve D E, which nearly touches zero at about 48 degrees. The speed assumed is, therefore, the practical maximum for this engine, unless means can be found to reduce the weight of the piston and rod, which, it must be admitted, are about as light as conservative design and the best of materials would justify. Curve F G is the expansion curve combined with the inertia curve.

A similar calculation for a 4 x 5-inch engine, in which the reciprocating parts weigh 6 pounds, and the large end of the rod 1½ pounds, shows that with a speed of 1,200 r.p.m. the inertia force and compression are nearly equal at 50 degrees. As this speed is frequently exceeded in automobile motors, the reason for the abnormally light design of the pistons and rods of engines of the De Dion type is at once manifest. The factor of safety in these parts is hardly large enough to be worth considering, but it is only the paucity of this factor that makes such speeds practicable on any terms. These motors have at least shown that by using a piston length only equal to the diameter with semi-steel for material, and the very thinnest and most accurate of castings, a piston for a bore of 100 millimeters can be made to weigh only a trifle over 2 pounds, and the connecting rod and wrist pin will weigh less than as much again. We may, therefore, say that for ordinary launch engines the limit of speed is from 1,200 r.p.m. for small engines down to about 800 r.p.m. for the largest.

The question now deserves consideration: Is there any good reason why this practical maximum of speed can not be made the normal speed for continuous running? Personally, I think that where pleasure craft are concerned, the time when this will be the case is not far distant. It has been shown above that there is no real obstacle in the way save that of maintaining the bearing surfaces at these speeds; but that obstacle itself is more apparent than real, and is due, in my belief, largely to defective or old-fashioned methods of lubrication. The old idea of drop-by-drop lubrication, while perfectly adequate so long as speeds were low, must give place in modern engines to the principle of a continuous stream of oil, fed to every impor-

tant bearing, collected, settled or filtered, and used again. This principle is already well exemplified in high-speed steam engines, turbines and electrical machinery; and it is employed to a limited extent in automobile engines, but nothing like as generally as it deserves to be, and easily can be applied. The crank pin, in particular, is in very few engines lubricated as well as it might be, and in most automobile motors oil is fed to it at what I regard as diametrically the wrong point, namely, the top or pressure side of the crank pin bearing, instead of the slack or cap side.

The fact is perhaps significant that ball

bearings of the type first made popular by their use in the Mercedes automobiles, and now extensively used abroad in automobile transmission and wheel bearings, have this year been applied to the crank shafts of three separate makes of automobile motors—the Mercedes 70 H. P., the Hotchkiss and the Charron, Girardot and Voigt. These bearings seem hardly likely to be applied to crank pins, but if they prove successful as main shaft bearings they will constitute a notable improvement in high-speed gas engines of moderate size; and, of course, their use will considerably simplify the lubrication problem.—*American Machinist.*

RAILWAY MOTOR CAR.

Motor Car No. 1, recently designed and built by the Union Pacific Railroad, for local traffic over the lines of this company out of Portland, Ore., is the name of the first gasoline railroad car used for combined passenger and baggage service in America. The automobile has within the past year been installed as an adjunct to railroad lines in sparsely settled districts, doing scheduled service over public roads in places where steady train service would not be profitable, but this is the first occasion in which the gasoline motor has been placed side by side with the steam locomotive, running on its steel track and carrying passengers and baggage at a rate exceeding that at present made by the steam car in the same service.

Motor Car No. 1 had its initial run over the company's lines on April 2, between Valley and Omaha, Neb., when it made the trip in 13 minutes less time than required by the trains on the road. The speed averaged 30 miles an hour, and could have been 40 but for a slight fan trouble.

The car is strongly mounted on the usual form of coach trucks, and is swung on a combination spring suspension so that the teetering movement so common in short railroad cars or single truck street cars is overcome. This is accomplished by placing a pair of wheels near the front and the other at the rear, with short elliptical springs between the top of the truck and the floor of the car. Forty-two-inch steel wheels run in long plain bearings and the motor plant and transmission machinery are mounted on the truck frame.

The six-cylinder, 100 H. P. motor, built by the Standard Motor Construction Company, is similar to that used in Standard racing boats last year, but has been redesigned and built in accordance with the railroad company's plans. The power is transferred as direct as possible to the drive wheels through a clutch and speed change gear. An ordinary water cooling arrangement is used, with circulation effected by a gear-driven pump. In summer the water from the cylinder jacket is cooled by passing through coils of tubes beneath the floor of the car, but in winter it is passed through a series of coils passing around the interior of the car, the heat of the water being used to heat the car. Between the motor and these two systems of cooling is a controlling valve operated by the drive of the car, and by which part of the water may be passed through each of the coils, according to the amount of heat required in warming the car and to the amount of cooling needed in keeping the water in the jackets at a proper temperature. Beneath the floor is carried a 200-gallon gasoline tank, from which the fuel is fed to the cylinders by a positive automatic pump system.

The body of the car has been designed to reduce wind resistance, the sides tapering at the front to a sharp angle and rounding at the rear much like a boat. The roof is perfectly smooth, except for the Cottler ventilators, and is shaped to offer as little resistance to the atmosphere as possible. Ventilation is effected by having all vitiated air withdrawn through the ventilators by suc-

tion created by the speed of the car. Pure air is admitted through one central tube which divides and subdivides into numerous small ducts admitting the air equally into all parts of the car, and thus avoiding any direct draft in any part of the car. In winter time the incoming air is heated by passing over heated coils connected with the motor. To facilitate cleaning the interior of the car has been made perfectly plain, and the floor is water-tight, in order that it may be flushed out with hot water without danger

The entire control rests with the operator, around whom the motor, carbureter, spark, acetylene headlight is used, and within the car lighting is through opalescent panels, which diffuse the light coming from acetylene burners concealed behind them. The rear door is held closed by an air cylinder, another of which raises and lowers the step to the rear platform so that the step is folded up when the car is traveling, but so that a slight movement of a driver's lever lowers it and opens the door.—*Motor Age*.

THE KINGSTON AUTOMATIC CARBURETER.

The new Kingston automatic carbureter is designed to meet the demand for a high-grade automatic compensating carbureter, and involves a certain combination of features that are new and shown for the first time in this form. In the illustration the carbureter is shown partly in section, the carbureting chamber is located in center of constant level cup surrounded by a horse-shoe-shaped float, which is made of cork with a light covering of copper, this combination making a very substantial float, as the copper strengthens the cork, keeping it from warping or becoming saturated and heavy, and the cork adds to the strength of the copper and keeps it from becoming punctured or crushed out of shape. Much lighter copper can be used in this manner than where no filler is employed. The float is not attached to anything, but lies on a flange surrounding the carbureting chamber; over its ends are projecting flanges which serve to keep that side from rising when floated; the opposite side of the float is free to rise and engage stem of ball valve B controlling the flow of liquid fuel through inlet G to constant level cup. Spray nozzle T is also located at the center of constant level cup at an equalizing point in carbureting chamber, and is adjustable by needle-screw A. Inlet pipe to motor is connected at H. Throttle at J is provided with an adjustable low-speed stop at K, and a lever, L, is attached to J for operating throttle, which may be opened by hand from steering post, by foot pedals or by governor, as the bearings are such that it may be adjusted to operate very freely. The throttle is so constructed that it may be assembled from either side, thus bringing the operating lever on the right or left side of carbureter as de-

sired. All of the air passing through carbureter must enter at I and pass the automatic valve V. A ground union fitting is provided at I, to which piping may be connected to supply warm dry air in cold or damp weather. To the stem of the automatic valve V a large flexible membrane, D, is attached, with its outer edge securely clamped by screw cover shown on top of carbureter. Above the membrane D is a practically air-tight chamber, the only opening to communicate with the surrounding atmosphere being at F, the size of this opening being adjustable by means of screw F.

The automatic valve V is opened by the partial vacuum in carbureting chamber due to suction of motor and acting on the face of valve V, and the large membrane D, the combined area of membrane and valve equal about 24 times the area of the inlet pipe, thereby reducing the chances of wire drawing the motor by the pressure necessary to operate this valve. Spring S tends to close the valve between the suction strokes. The speed valve V is controlled by the amount of air allowed to pass in and out of chamber above the membrane D through the adjustable air opening at F.

At C is shown a hollow screw forming a guide for valve stem and used for adjusting the automatic valve off its seat for the purpose of correcting the mixture at low-speed position, thus forming the initial air inlet within the regular inlet and taking all the air from one source, giving the advantage of supplying warm air at low speed as well as the high when necessary. E is a lock nut for locking C in position after adjustment is made.

In operation: Connect to intake pipe of motor with standard pipe connections at H.

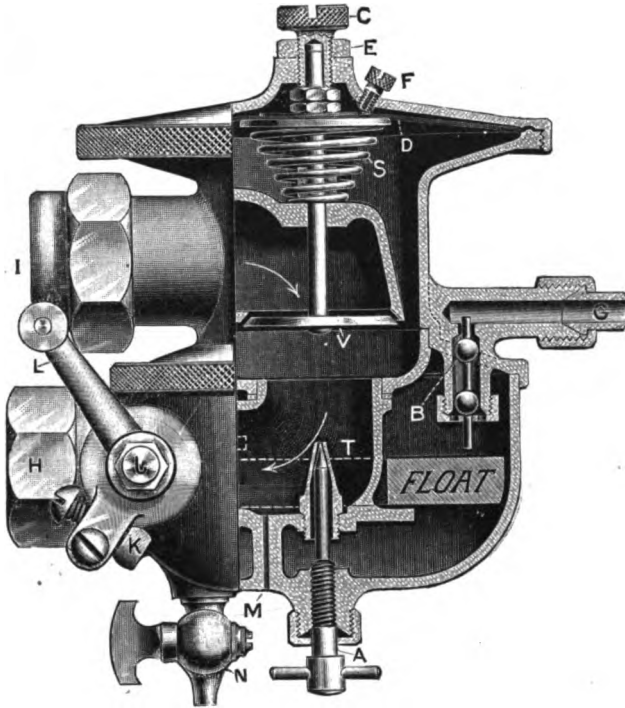

The Kingston Automatic Carbureter.

Connect the fuel supply at G with $\frac{1}{4}$ -inch seamless tubing, using union connection, or take off the union fitting and connect with $\frac{1}{4}$ -inch standard pipe, which should be of brass, as iron may rust and cause trouble. Give head enough to insure a flow to carbureter. Connect warm air pipe by union connection shown at I, and extend same to some place where warm air can be obtained when motor is running. Warm air may be taken from near the exhaust pipe with good results where it is convenient, but this piping should be so arranged that it may be adjusted close to the source of the heat or a slight distance away from it, while on a damp or cold day it is very necessary and should be so adjusted as to just keep frost from appearing on the inlet pipe between carbureter and motor. Open fuel regulating screw A about one turn, press down on the spring flushing device (not shown in sectional view) until fuel will drip from carbureting chamber at M, then open throttle J wide, by lever L, then start the motor, and when motor starts adjust A until the mixture is perfect, with open throttle, and the motor will develop high speed and power, and no smoke will be emitted from the exhaust. Next close throttle against

stop K to low speed position, which is adjustable by screw against K. When throttle is first placed in low speed position the mixture will show too rich and smoke will puff from the exhaust, then adjust the screw C down carefully by turning it to the right.

This will press the automatic valve V from its seat, admitting a small fixed quantity of air to the carbureter chamber without operating the automatic valve. When the screw C is adjusted to the proper position to admit the exact amount of air to mix with the quantity of fuel drawn at this position the motor will run smoothly at a very low speed. Then screw C should be locked in position by nut E. There is now an adjustment for both high and low speed which is perfect. Now test the intermediate positions, open throttle quickly and the motor should speed up like a flash. Should it hesitate for want of fuel, then screw F down a part of a turn; this will not admit air as freely in and out of chamber above the flexible membrane, and consequently the automatic valve will not act so quickly, which will cause more suction on the spray nozzle T, while the automatic valve is opening. If on

opening throttle quick motor smokes, the screw F should be opened slightly, which would decrease the suction on spray nozzle and correct the mixture. Carbureter should require no further attention, except to draw off whatever water or dirt may accumulate in float cup about once a week, by drain cock N.

At high speeds the automatic valve V, controlled by membrane D, and adjustable air control F, will remain wide open. Then if a heavy load is thrown on that will tend to slow down the speed of motor, the valve V will partly close, maintaining a constant suction on spray nozzle T and compensating perfectly to any speed

THE WESTERN GAS ENGINE.

"Necessity is the mother of invention," and out of the necessities of the Pacific coast has developed the Western engine. Briefly stated, the conditions required in a gas engine on the Pacific coast are these: Adaptability to heavy constant loads, principally for water pumping for irrigation; adaptability to the heavy cheap native distillates, which are much more difficult to vaporize and gasify than our Eastern gasoline; simplicity of mechanical construction, as most of the engines go into the hands of inexperienced farmers; automatic action so positive that the engine may be left for many hours without attention under constant load; price and quality to compete successfully with more than a score of other makes of engines, both Eastern and Pacific coast built. As the same conditions prevail in other parts of the country, a description of how the Western meets these requirements may be interesting.

The accompanying sectional view of the cylinder head and vaporizer shows the construction of this portion of the engine. Fuel is maintained at a constant level in the small reservoir by a pump feed, with overflow back to supply tank. A little above the fuel level is an opening of good size that can not clog, this opening being closed by the flat cone-shaped end of the screw valve at the top of the vaporizer. The air rushing by sucks up the fuel and it is broken into a fine spray as it strikes the end of the valve screw. This mixture of air, and fuel inspray, passing by the vertical inlet valve impinges against the hot surface of the vertical exhaust valve, still further breaking up the fuel into gaseous spray and at the same time assisting to cool the exhaust valve. This vaporizer was designed especially for California No. 2 Distillate and handles it well. The vaporizer, taking the heavy distillate, atomizes it and throws a large portion of it into gas before it enters the cylinder. This allows of a high compression, so that the piston area is considerably reduced over the ordinary engine. By a peculiar device of their own the builders claim a greater horse-power for size of cylinder than has hitherto been achieved by other makers of horizontal engines. This greatly reduces the weight—a valuable feature in transportation and portability.

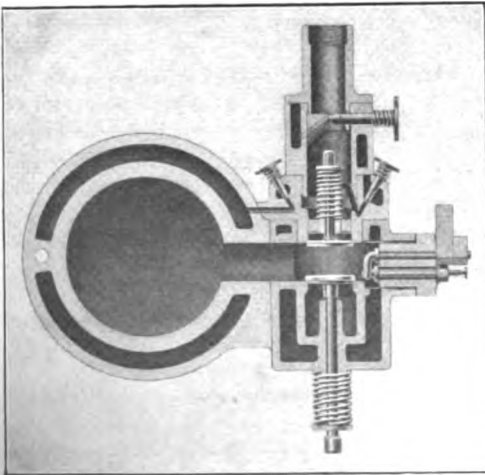

Sectional End View, Showing Valves, Vaporizer, Etc.

The engine is built by the Western Iron Works Company, Los Angeles, Cal. The action of the engine is perfectly automatic, the governor being of centrifugal type, hit-and-miss, and very sensitive. An important feature is the water circulating pump, which constitutes an integral part of the engine, insuring proper water circulation. This device and the light weight of the engine, with its very

even balance, makes it especially satisfactory as a portable. The makers are prepared to substantiate their claim that it will burn any fuel, from gasoline to kerosene. They state that they can start on ordinary kerosene, using a trifle of gasoline to get under way and get full power within a few minutes from the time of starting. They report tests with kerosene which show that without any special device, generator or other accessory, the engine can be changed over from one fuel to the other and run equally well. This is especially valuable in a gas engine and allows its economical and satisfactory use where an even and regular grade of light fuel is not obtainable. The builders are prepared to fill orders from any part of the United States, and solicit export business, having the best of shipping fa-

cilities via San Francisco or San Pedro to all parts of the world. They report a large accumulation of orders, and their factory is running twenty hours each day. Their plant will soon be extended to take care of the rapidly increasing business.

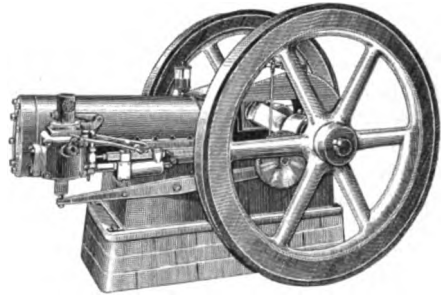

The Western Gas Engine.

PROGRESS OF THE GAS ENGINE.

In a recent article in *The Ohio State Journal* Frederick Collins calls attention to the fact that when we consider all that man is able to do in the way of converting coal into power by means of the steam engine, we are apt to consider him a "little god," but when we look on the real instead of the spectacular side we find that man is really wasting about 90 per cent or more of the available energy of the coal.

The invention of the internal combustion engine, as the gas engine is called, says the writer, is a long step toward the direct conversion of fuel into power, and for this reason it must be seen that it is more economical in actual service than the steam plant. Every one is familiar with gas engines in small sizes, thousands being in constant use throughout the United States, ranging from 1 to 50 H.P., and obtaining their supply of gas from the ordinary street mains. But economy is not typified in these engines.

When the gas engine is equipped with its own gas producer, as the plant is termed by which the gas utilized is made, it shows the remarkable decrease in fuel consumption, and so rapid has been the development of this form of power generators and so ever increasing the size of the units turned out that the steam engineers have had cause to look to their laurels, as their unparalleled activity in evolving the

steam turbine has shown. This is the kind of competition over which capital seems to have little control, and it is based on the laws of natural selection, in which the fittest will survive just as much as in the progression of the animate bodies, upon which Darwin based his theory of evolution.

A comparison of the performances of the best types of triple expansion Corliss engines and gas engines, even of the smaller sizes, shows that when the fuel economies of the gas engine are considered its first cost where it replaces the former will be compensated for within a very few years. Thus the fuel consumption of the best type of compound condensing steam plant is from two and a half to four pounds of coal per H. P. per hour, and in many steam engines, especially of older design, now in use the coal consumption is actually criminal, ranging from six to ten pounds per horsepower.

On the other hand, with the best type of gas plant and a gas engine of modern design 1 H.P. may be developed for one hour by the expenditure of one pound of coal.

In gas power plants two processes are involved—namely, the conversion of the fuel into gas and then the combination of the gas in the cylinder of the engine developing the power. The cheapest gas suitable for power that can be furnished is

made from anthracite or bituminous coal, coke or wood by passing air and steam alternately through deep beds of fuel brought to incandescence.

There are two different systems for generating this kind of power gas, and these are broadly designated as "pressure" and "suction" plants, depending on their method of operation. While the pressure system has not met with the favor that the suction has, it is nevertheless being extensively used, and to illustrate the difference between the two it may be described briefly as follows: In the pressure system the air necessary to maintain the fire in the gas generators enters the bed of fuel under the pressure caused by a steam jet blower or a fan, when the gas will pass through the apparatus and reach the engine under a pressure.

In the suction system the air required for the generation of the gas is drawn through the fuel bed and the resulting gas through the cooling and cleansing apparatus by the

sucking or draught action of the engine piston.

The great advantage the gas engine designers have had over the steam engineers is that they have learned all that the modern school of steam engine building could teach them and have applied these teachings in the construction of the new motive power. The success of the steam turbine has served to stimulate the gas engineers to bend their energies in designing a gas engine along the same fruitful lines.

Mr. Lewis Nixon even goes to the extent of announcing that the end of the steam age is practically at hand, and in this connection it is interesting to note that a locomotive fitted with a gas engine is now being tested to determine its efficiency as a motive power to supersede steam on railroads.

In any event, the time is rapidly approaching when the steam engine in any capacity will have to take a secondary position as a power producer.

TRADE PUBLICATIONS.

"The Reason Why" is a pamphlet from the Duryea Power Company, Reading, Pa., and relates to the merits of Duryea vehicles.

Fox's Reversible Engine Works, Covington, Ky., have a circular showing the new type of reversible engine built by them.

The Frank M. Watkins Manufacturing Company, Cincinnati, Ohio, is utilizing a monthly blotter to call attention to its stationary and marine gas engines.

The Western Iron Works, Los Angeles, Cal., are issuing a well-printed catalogue of their engines, which are more fully described in another column of this issue.

A mailing card from the Hart-Parr Co., Charles City, Ia., shows one of their gasoline traction engines operating a thresher in Minnesota. These traction rigs are all oil-cooled.

W. S. Sheppard, M.E., 21 Lawrence street, Newark, N. J., has made a special study of gas engine lubrication, and a new booklet tells the advantages of his "Ideal" oils for automobile, stationary or marine engines.

The "Flour City Gopher" is a 2½ H. P. horizontal engine, with or without pumping attachment, which is described in a folder received from the Kinnard-Haines Company, Minneapolis, Minn.

The Beaver Machine Company, 220 E. Second street, Cincinnati, Ohio, have used, in their new circular, an illustration of a beaver to show how good a worker the Beaver engine is. This is a 3½ H. P. horizontal engine, mounted complete on skids.

"The Motor that Motes" is the significant phrase on the 1905 catalogue of the Bridgeport (Conn.) Motor Company. Sectional drawings, detail measurements, etc., constitute a novelty in this catalogue, as such information is not usually given out broadcast.

A new marine engine catalogue from the Frank M. Watkins Manufacturing Company, Cincinnati, O., is by far the best we have yet received from that company. It has an attractive cover, is well printed in two colors and the halftones are very good. While the Watkins Company makes both two and four-cycle types, this catalogue re-

lates only to the former, for marine service. They are built in units from 2 to 12 H. P. Launches from 16 feet up are also shown.

The Wooley Foundry and Machine Company, Anderson, Ind., have issued a new circular, showing, in addition to their standard Burger automatic gas engines, a new tandem engine.

McDonald & Erickson, 36 W. Randolph street, Chicago, Ill., are making a specialty of a $4\frac{1}{2}$ H. P. vertical two-cycle marine motor and an 8 H. P. of the same type. A circular just received gives details of these two engines, as well as some accessories handled by this firm.

The Capital Gas Engine Company, Indianapolis, Ind., is getting out a new catalogue, containing many illustrations of Capital engines. This company also has under way a very fine lithographed poster, mounted on heavy cardboard, and showing the various styles of Capital engines.

"Gas Fluctuation—Cause—Remedy," is the title of a catalogue received from the Broderick Antifluctuator Company 330 W. Third street, Cincinnati, Ohio. This device is utilized to prevent fluctuations in service pipes supplying gas engines, and was fully described in our last issue.

ITEMS.

The Streit Machine Company, Harrison avenue, Cincinnati, are bringing out a new four-cylinder design, to be rated at 16 H. P.

The Stone Manufacturing Company, 110 Orange street, Wilmington, Del., report that their capacity is well filled up with orders for their marine engines.

Ball bearings have made their appearance in automobiles. We wonder if they will become as essential to the public as did the ball bearings on bicycles.

The Hart-Parr Company, Charles City, Ia., expects to erect 83x170 and 60x84 feet additions to its plant, to increase the capacity of the foundry and machine shops and to extend work along the line of building traction gasoline engines. The buildings will be fitted with traveling cranes and used principally for erecting work.

R. E. Mathot advises a flow of at least $5\frac{1}{2}$ gallons of water per horse-power per hour in engines using circulating water systems for cooling. For engines using the cooling tank system he recommends a capacity of 45 to 55 gallons of water per horse-power for hit and miss engines, and 55 to 65 gallons for throttling engines.

In a paper recently published in the *Revue Technique*, M. L. Levi makes the calcrific values of different fuels used in internal combustion engines. British thermal units per pound: Methylated alcohol, 10,620; methylated alcohol mixed

with 50 per cent gasoline, 14,200; crude American oil, 19,630; refined American oil, 19,880.

The George N. Pierce Co., Buffalo, N. Y., have offered prizes for the best design of a body for an enclosed automobile. for the best body for a touring car, and for the best color scheme for any motor car. A first prize of \$250 is offered for each of the first two, with a second prize of \$100. For the last contest the first prize is \$200 and the second prize \$100. The contest closes June 1st.

With a view to encourage the use of gas motive power purposes, the following scale of discounts has been arranged by an English gas company: For an engine consumption during the quarter not exceeding 25,000 cubic feet, 10 per cent; from 25,000 to 62,500 feet, $12\frac{1}{2}$ per cent; from 62,500 to 125,000 feet, 15 per cent; from 125,000 to 250,000 feet, $17\frac{1}{2}$ per cent; from 250,000 to 500,000 feet, 20 per cent, and over 500,000 feet, $22\frac{1}{2}$ per cent.

The editor of *Rudder* gives the following answer to an inquiry as to why the incoming charge in a two-cylinder engine is not ignited by the hot gas:

"The explosion drives the piston down until it opens the exhaust port, and as the gases still have a pressure of from 20 to 40 pounds per square inch, the instant this port is opened the gases escape at such a high speed that they leave a slight vacuum in the cylinder by the time the piston has gone

down far enough to open the incoming port. The shock caused by the rapidly moving gas has a tendency to destroy any flame that may try to remain, and the shock of the incoming cold gas has a similar effect. A poor charge of incoming gas is more apt to take fire, owing to the fact that the previous explosion did not leave enough pressure to exhaust itself in the manner mentioned."

An English firm is said to be building a ship of 800 tons burden, to be equipped with a suction gas and gas engine power plant.

A 1,200 B. H. P. gas blowing engine has just been made by the Societe des Acieries de Longwy by the Societe Francaise de Construction Mecaniques, at their Denain works. Three engines of this size are being constructed. Each has two gas cylinders placed side by side; the piston rods in both cases being prolonged through the cylinder covers to work the blowing cylinders, placed tandem with the gas cylinders, which are water jacketed, and each provided with a hole, through which the condition of the inside walls can be examined. The pistons are made of cast steel. Each cylinder is provided with two valve boxes placed at the

sides at each end. This arrangement was chosen to avoid massive castings, and to facilitate the inspection of the exhaust valves. By its use all the levers for regulating and starting can be grouped together, so that the driver readily controls the charge, ignition, etc., while standing in one place. In addition to this the various moving parts are easily seen and taken care of, while the regulating and starting of the engine can be done from the engine house floor level.

In an English article on "Recent Gas and Oil Engine Developments," the author says: "Most of the engines exhibited at Earl's Court were of the single-cylinder horizontal type. They showed that development is proceeding along the lines (a) of higher compression of the charge before ignition; (b) of employing electric ignition in lieu of tubular; (c) more convenient means of starting; (d) in large engines, of water cooling for the exhaust valves. These advances in recent years, combined with better governing, have brought about considerable reduction in the cost of gas for working, and increased satisfaction in uniformity of power generation."

FOX'S REVERSIBLE ENGINE.

By making a specialty of a 5 x 5 engine, by selling for cash only and direct to the engine user, Fox's Reversible Engine Works, Covington, Ky., say that they can furnish a first-class engine for a very reasonable price.

The accompanying illustration shows a new style of engine brought out by this company. It is 5-inch bore, 5-inch stroke, rated at 5 H. P. at its normal speed of 500 r.p.m. It is of the two-cycle type, with head and cylinder cast in one piece. The height over all is 25 inches, diameter of crank case 11 inches, crank shaft $1\frac{1}{2}$ inch, main bearings 3 inches, fly-wheel 17 inches. The speed of the engine (from 200 to 800 r.p.m.) is regulated by advancing or retarding the spark. A reverse lever, doing away with a reversing clutch or propeller, enables the operator to reverse the engine. Jump spark ignition is used.

For stationary use the engine is supplied with an automatic governor. If de-

sired, a set of castings with working drawings can be furnished for those who desire to do their own machine work.

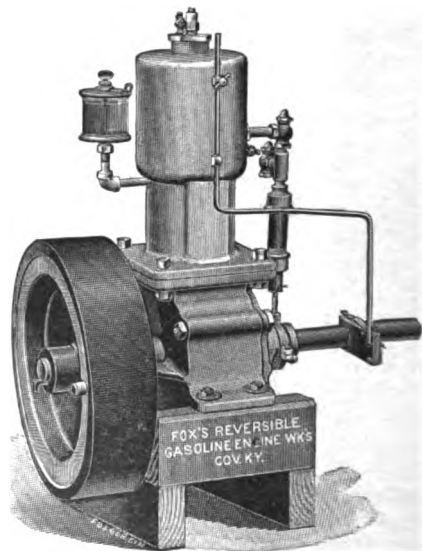

THE GAS ENGINE.

STATIONARY—AUTOMOBILE—MARINE.

PUBLISHED MONTHLY BY

The Gas Engine Publishing Co.

Blymyer Building, Cincinnati, Ohio.

ADVERTISING RATES ON APPLICATION. Address All Communications to the Company.

Entered at the Postoffice at Cincinnati, Ohio, as Second Class Matter Feb. 20, 1899.

VOL. VII.

JUNE, 1905.

No. 6.

Domestic Subscriptions, \$1.00 per Annum. Single Copies, 10 cents. Foreign, \$1.50 per Annum.

About a year ago we published several articles on the relation of artificial gas companies and gas engines. The information was secured by sending to gas companies questions to be answered by them, and the tendency of these questions was to ascertain what efforts were being made by the gas companies to secure the installation of gas engines. We were led to make the inquiries by the fact that in the 1904 "Question Box" of the Ohio Gas Light Association the inquiry, "Do not manufacturers of gas and gasoline engines give preference to gasoline over gas; if so, why?" was answered in such a way as to indicate that the gas companies felt the manufacturers of gas engines did not work hand in hand with the gas companies in securing the largest possible installation of these engines, irrespective of the fuel used. The information secured and published in the articles referred to indicated that some of the gas companies were very energetic in securing the installation of gas engines, while other companies were very lax in the matter.

This year's "Question Box" is very much larger than last year's in all respects, but the section on gas engines shows that the gas companies of the country are, in many cases, very much alive to the importance of doing what they can to understand thoroughly the methods of operation of various engines, the advantages of each, and the best means to secure their installation and satisfactory results from them. This is shown by the fact that almost 20 per cent of the inquiries in this year's "Question Box" relate either directly to gas engines or to the production of power gas. We believe that the gas companies who are not already making active efforts to secure the installation of gas engines are losing an excellent opportunity to increase the sale of gas at rates on which they can make a fair profit. The companies who are pushing this

branch of their business are securing the installation of many engines and attracting to themselves business which would otherwise never come to them. It is not always convenient to use gasoline for fuel in gas engines, and in most cities a little effort on the part of the gas companies (especially if aided by active work on the part of gas engine manufacturers) will produce wonderful results.

A noteworthy innovation in the fishing industry of Scotland is the introduction of boats propelled by motors. Experiments have demonstrated the great advantages of such boats over sailing craft in calm weather or when the wind is unfavorable.

At the recent trade exhibition in connection with the seventh session of the international railway congress at Washington, there were shown a number of applications of the gasoline engine for railroad work. Aside from stationary engines for pumping water, etc., there were railway inspection cars propelled by gasoline motors. A few years yet and the gasoline-propelled railroad car will be in evidence at such exhibitions as this.

As is pointed out in another column, the gasoline engine will have an advantage in Chinese trade because it does not violate the religion, or superstition if you will, of the natives. Anyone who knows anything about the Chinese persistence in sticking to the religion and implements of his ancestors, knows that to be able to offer something which does not interfere with his ideas of what is right gives an immense advantage. And while the sale of gas engines in China may at this time appear to be most unpromising in quantity, yet it is certain to develop in time into a good field.

THE REASONING GAS ENGINE OPERATOR.

BY ALBERT STRITMATTER.

Every once in a while the gas engine enthusiast is apt to think that the gas engine is getting so well introduced now that there is no excuse for any one not knowing something about these engines. The writer seldom begins to feel that way that he does not soon come against some questions which make him believe the gas engine is an unknown quantity. Two such occurrences have happened recently.

The first occurred in talking with a man who is engaged in the machine tool business, a man who has traveled pretty thoroughly over the Central and Eastern States, and who presumably has occasion frequently to go into the shops of his customers, some of whom probably use gas or gasoline engines for driving their machinery. He has recently been obliged to face the possibility of moving his own shop into a building where he will have to furnish his own power. In talking of it, he asked the writer: "Can a gas engine be depended upon to run our shop right?" After thinking how to answer him, I told him to go to any gas engine company and have them refer him to firms using the gas engines for such service. By so doing he could best convince himself.

The other occurrence before referred to was on the occasion of reading in a paper devoted to blacksmiths, etc., the following statements by one of its readers: "I would like to know if a gas or gasoline engine can be depended upon for grinding. I have never seen many gas or gasoline engines, but all I ever did see only pushed while going in one way, and then left the momentum of the fly wheel to run it for $1\frac{1}{2}$ revolutions." But while the writer of this inquiry seemed to doubt the ability of gas engines to give steady power, he wrote with not much better appreciation of the steam engine, saying: "The steam engine is not as good to drive burrs with as the old water wheel, on account of the jerk in it caused by the slacking of the speed while the engine crank is passing the center." The steam engine people often join in the statement that gas engines are not well governed, but I can imagine the confusion of some of them on being told that their steam engines "slacked speed while passing the center."

Of course, the whole situation of this lat-

ter case is that the inquirer evidently never saw either a first-class steam engine or a first-class gas engine. The technical papers are every day appearing with descriptions of installations of gas engines which are doing all kinds and classes of work, including the operation of all sized electric generators, which is undoubtedly the severest test that can be applied to a gas engine, as to its reliability and speed regulation.

But the point that many of these investigators of the gas engine do not bear in mind is that there are all kinds of gas engines, and that one can not expect a poor engine to do good work. Operating flour mill machinery does require a close regulation in speed, but the fact that there are hundreds of this type of engine doing this class of work ought to be convincing evidence to any one who doubts the ability of the gas engine to perform such service as satisfactorily as a steam engine or water power.

This same inquirer asked in the same letter: "Could a cast iron grinding mill be used by such unsteady power?" One of the largest manufacturers of such grinding mills recently told the writer that they had had so many calls for gasoline engines to operate their mills that they had been compelled to go into the manufacture of these engines themselves in order to do justice to their trade and secure for themselves the largest amount of profit from the engines which they were obliged to furnish.

"The gas engine business is the hardest thing I ever undertook," recently remarked a dealer in second-hand machinery. "All the time I have been in business," he continued, "I have never had more than four complaints from my customers, and those four were on gas engines I had sold. In one case I bought a 2 H. P. engine and had a mechanic, who has been in the gas engine business for ten years, overhaul it. And you know that when he says an engine is right, it is all right. But the people who bought it say they can't start it and are going to send it back.

"In another case I sold a man a second-hand engine of a certain make. The people couldn't run it, and I took it back and sold them a new one of the same make. They couldn't start it, either. I wrote to the manufacturers, and one of the firm went down

there. When he got there he told the people that he was not going to touch the engine, but would tell them what to do and let them do it. 'Work that pump, turn in this switch, move that lever,' he instructed them. 'Now pull back on the fly wheel and let her go,' he commanded, and off the engine went. Now, that's the trouble with the gas engine."

The dealer's story is an old one to me. I have heard it over and over again, but not always applied to a gas engine. A number of years ago a concern manufacturing flour mill machinery sold to a miller a machine known as a 'purifier,' which, as its name indicates, purifies the flour of impurities. As is not unusual with all kinds of machinery, the pulley which received the power from the line shaft was intended to turn in a certain direction, designated as 'with the sun.' That is, as you stood looking at the driven pulley it turned in the direction of the hands of a clock. This direction was indicated by means of an arrow painted on the woodwork just beyond the pulley. As soon as the purifier was installed the company got a letter from the miller that the machine was absolutely useless and failed to do the work. After considerable correspondence an expert was sent and found that the machine was being 'run backwards.' That is, the driven pulley was running 'against the sun' instead of with it. Reversing this, there was no further trouble.

Machinery men in all lines meet with troubles like these. There are some people who so absolutely ignore the consequences of their negligence in regard to the care and understanding of a machine that they will always have trouble, no matter how simple or automatic the machine may be.

The successful man, in whatever calling he may be, is the one who is able to adapt himself to the conditions as he finds them, and the successful gas engine salesman must have the ability to instruct his customers in the principles of operation of the engine and in the process of reasoning which will help every gas engine trouble, provided the engine is not radically wrong.

For instance, a gas engine runs along nicely in the winter and spring. The operator never has a bit of trouble in starting it the first time in the morning. But the very first real hot day, a day when every one feels like doing as little hard work as possible, on that first hot day of the summer, the engine will not start. The operator tries again and again, wondering why the en-

gine should have picked out such a warm day to demand so much energy from its caretaker. If he is the kind of man who rushes off on all occasions to the manufacturer or dealer who sold the engine, he will demand an expert to come out and start the engine. If, however, there is no one near at hand for the purpose, or if he belongs to the reasoning type of operators, he will not pull at the engine indefinitely, but will begin to look around and reason out the cause of the trouble. In the first place, the engine has run so many times and has started with so little trouble that it is reasonable to assume that there is nothing radically wrong. After investigating the igniter, to see if these is a good 'fat' spark and the valves, to see that they work properly, the fuel feeding devices, to see that the engine will be kept supplied with fuel, it perhaps occurs to him that neither the valves nor the fuel-feeding mechanism can be the cause, for the reason that the engine does not fire the starting charge of gasoline which he uses. As he has examined the igniter a number of times, he knows that it is all right. Perhaps there is something the matter with the gasoline, but on touching a match to some of it the fuel readily flames up, so there is evidently something else the matter. After turning the engine over a few times idle and with open relief cocks to empty the cylinder of the priming charge, he carefully measures out his starting charge and tries to start, but with the same failure. Again he recalls that the priming charge is the very same size as he has used all winter, even in the coldest of weather, and he has drawn it into the engine very slowly, so as to be sure that it vaporized well, for last fall he had trouble in getting the charge to vaporize sufficiently to ignite, and so he finally had to increase the size of the charge—ah, that's just it! During the cold weather he used an increased priming charge because the gasoline would then vaporize sufficiently to form a mixture which would ignite. Now on this hot day the conditions of the weather are reversed, and practically all of the priming charge vaporizes instead of a portion of it remaining in liquid form and falling to the bottom of the cylinder. The result is that as the entire charge vaporizes it is too rich, has too much gasoline for the amount of air, to ignite. Reducing the charge to two-thirds or one-half the former quantity results in his starting the engine as usual, and all will go well till next fall.

EXPERIENCE.

By M. T. MINOGUE, M. E.

At the present stage of the gasoline motor industry, and its application of power for the various uses for which it is applied, it stands in the center of the entire world a very interesting object, upon which a great army of the brightest mechanical brains are focused. Day by day that great army is steadily increasing.

To the newcomer and those of limited experience I especially wish to direct my remarks. The amateur, after he has studied enough to get a rough idea of the construction and operation of an internal combustion motor, makes his designs and constructs an engine along such lines as he has learned in a theoretical way only, and when such construction is complete, according to his design, he gives the wheel a turn; it starts off, Bang! bang! bang! and the louder and more terrific the noise that it makes the better the music to his ears. If he would only stop there and think, and have just enough judgment to reason with himself and say: I have learned entirely the alphabet of the gasoline engine and henceforth I am prepared to learn my lessons. But in how few cases does judgment serve the amateur thus. For in that happy and delighted moment he imagines that he knows the "ins" and "outs" of everything pertaining to an internal combustion motor, and later on he will discover his mistake, and as he sees and realizes it he will come to the conclusion that he must turn back to the original starting point, and take up each part, its workings and its proper actions, and analyze them carefully and build up his fountain of knowledge from the base of *experience*.

After years of experience along this line he will recall the day that he completed his first motor, and then he can realize how little he knew at the period when he had first learned the alphabet of internal combustion motor construction.

It would be almost as reasonable to say that a person could read the preface or introduction of a book and turn to the last page, on which was written "Finis," and then relate the complete story.

It is a fact that at the present day better facilities are at hand for learning the

experience of the past up to the present day by the number of good publications and articles from the experience of others. The object of said publications is to encourage and promote the industry and to offer to the student a theoretical education upon the subject. But practical experience must be brought into action before one can hope for lasting and practical results. The object of this article is not to discourage you and leave your mind impressed with the idea that the ordinary motor is so complex and difficult to master that only master minds can cope with it. Not at all. But the object is to warn you that if you expect to jump immediately from the horizon to the zenith of success, that there are many wrinkles to be smoothed and many pitfalls to bridge over as you trudge along, and nothing will convince you so well as when your motor refuses to work on different occasions without any apparent cause. A few years ago the following appeared in an automobile publication, a communication to the editor:

"Dear Sir—Will you kindly give a formula for the construction of a gasoline motor" (naming a certain size) "in plain figures, without algebraic formulas? Since I have left school I have almost forgotten how to compute by algebra."

The editor's encouraging reply to this enthusiast was: "Any man not thoroughly acquainted with algebra has no business to try and design a gasoline engine."

Such an unreasonable reply to an honest and fair question would surely put a damper to an energetic brain that a more favorable and encouraging reply might lead on to a field of great success. The use of algebra is a correct and proper way for the designer to arrive at the proper solution after he has first conceived the proper idea of what he wishes to solve. The solution of the gasoline engine, its advancement and perfection is not found on any page of algebra. But it is found and is written on the pages of a book called Experience. When you are about ten miles from home on a country road in your automobile and it suddenly takes a notion to stop its horseless duties, what do you do? Do you go into your

pocket after your algebra and begin to compute? Let x equal the unknown cause of this unpleasant stoppage, and let xz and 49 turns of the crank make her go again? No, you don't! You recall in that little book of experience the chapter of Cause and Effect, and get out and fix a broken wire or adjust a vaporizer or some trifling matter—and a turn of the crank and you are off again. The mechanical construction and operation of a gasoline engine in itself is of the simplest nature, yet in all of its simplicity the combination which goes to make the machine complete and practical must rely upon certain parts of its combination that can not be called by any other name than delicacy, and it is to strengthen and overcome this delicacy that is taxing the brightest mechanical brains

Unlike any other power that has heretofore served mankind, in one particular it stands by itself—"there is no power behind the throne." Of course the necessary material that forms the combination, including the combustible, must be brought together, and by mechanical effort be compelled to work in unison,

but with the vapor engine the power is created almost instantly and lost in the next fraction of a second, and this repetition must be kept up constantly or the power ceases altogether.

The windmill receives its power from a current of air, whose speed and velocity is guided and directed by an unseen force. The steam engine must have constantly a proper pressure in the boiler to be fed in proper quantities to the prime mover. The water turbine must have great volumes of water at hand and depend upon the law of gravity in combination with the water supply to produce its results. Electric power must depend on a large storage battery for its supply of current. Thus it can be readily seen that the gasoline engine as a power producer is an entire product of manufacture, even to the fuel, and the only gift that nature bestows upon her is the air she breathes. Experience, then, confines herself more closely to the accessories that help form the combination than in the engine proper itself, and it brings us in touch with an old saying, that "Experience is a dear school, but all fools must learn."

A COKE GAS PRODUCER

By EMILE GUARINI

During the course of the year 1904 the "Societe Technique de l'Industrie du gaz en France" opened a competition for the best coke gas producer, intended for the production of gas suitable for motors or also for generating water gas. The company has recently handed its decision to the Congress des Gaziers (Gasfitters' Union).

Several candidates competed for the first prize, but only one of them, a Mr. Pierson, of Paris, has complied with all the necessary conditions and stipulations, enabling conclusive experiments to be organized and carried out before the Congress. This fact is all the more worthy of remark, as it is by no means rare to read, in connection with one gas producer or another, that it is suitable for the use of coke. It is, therefore, somewhat surprising to note that Mr. Pierson was the only candidate to appear, more especially as the prize, 5,000 francs was not to be despised, although nothing very extraordinary. Furthermore, the apparatus submitted had not even been constructed expressly for working with coke.

The apparatus submitted by Messrs. T. and O. Ct. Pierson is at Hery (Yonne), in a pyrotechnic establishment belonging to M. Gomant; it consists essentially of a Pierson gas producer with a combustion chamber of 23.62 inches diameter and a maximum height of about 5 feet 3 inches, and also of purifying apparatus comprising a vertical sheet iron refrigerator or cooler, a coke column and a purifier with Lancing material. It also comprises the following: A gasometer of 39.24 cubic yards capacity; a Crossley Bros. 35 H. P. motor, and, finally, the manometers, which are indispensable for controlling the satisfactory working of the plant. The experiments made covered a period of five days, and were carried out by Mr. Aude (Mr. Pierson's engineer), in the presence and under the supervision of a delegate appointed by the committee, and of the Secretary and Recorder of the Societe Technique. The fuel employed was No. 0 coke and small coke, supplied by the Compagnie Parisienne du Gaz, and small coke which was obtained from the Laroche

Gas Works. The tests made comprised analyses of the gas made with the aid of the Orsat apparatus, calorimetric measurements taken by the aid of the Junker calorimeter, and taking frequent diagrams showing the readings of the speed of the motor. The motor in question worked with remarkable regularity, a feature which is a sine qua non for the production of an homogeneous gas.

As a matter of fact, the working of the gas producer was remarkably constant throughout the whole progress of the tests; an irregularity occurred, however, for a few seconds on the third day, due, probably, to an accumulation of cinders, but this was immediately overcome by a skilful application of the poker throughout one of the upper inspection holes. Upon the termination of the experiments the producer was completely emptied and examined, when only a few pieces of clinker were found, which were removed upon the first application of the poker. A defect in the manufacture (completely foreign to the producer, however) rendered it possible during the course of the experiments to open some of the inspection devices in the piping. Abnormal deposits of cinders were not found in any part of the apparatus. The gas producer tested at Hery has a combustion chamber closed at the bottom by a circular grate with almost vertical fire bars. All waste products of combustion fall into a pit filled with water, so that they are immediately extinguished. Combustion is assisted by injecting air and steam around the grate and into a space shut off by a vertical partition extending down into water. The steam is generated in a boiler mounted on a platform on a level with the feed hopper. It passes through an injector, of the Korting type, which also carries along with it a suitable proportion of air, thus producing a mixture which is blown through the grate. The producer is charged at the top by means of a hopper, provided with a double fastening. The outlet for the gas, which escapes laterally, is about 5 feet above the top of the grate. The generating apparatus is completed by inspection devices at the sides and top, apertures for cleaning the grate (closed and bolted when at work), and a pipe for taking samples. The plant is also adapted to use French close-burning coal, and upon this assumption the producer has been constructed to yield from 4,200 to 4,600 cubic feet of gas per hour. This is

the model which Messrs. Pierson generally use for their 50 to 60 H. P. motors; it is intended not only for feeding the motor which is already put up, but also for subsequently providing the gas required by the movable forges. The producer had been worked with coke on a very few occasions prior to the official tests to which it was subjected. During the trials the motor, which was not used for driving the shafting in M. Gomant's works, was kept down to from 18 to 20 H. P., with a speed of 170 revolutions, excepting for brief intervals; but, due to the considerable heating of the brake, it was allowed to develop from 30 to 35 H. P. While working under these conditions the producer was charged with from 35 to 45 pounds of fuel per hour, and, in order to exactly determine this quantity, it was necessary to weigh the coke and then measure the quantity of gas produced therefrom. This latter condition could not be complied with at Hery, and, consequently, only secondary importance was attached to the quantity and output of the fuel used. The producer used at the Gomant works not having been fitted out expressly for using gas coke, it is certain that the results obtained would have been still better if the apparatus had been constructed especially for burning already distilled fuel. Coke—which is much lighter and often less pure than close-burning coal or anthracite—would require, especially as regards the gas producer itself, the apparatus being given much larger dimensions. Special study might perhaps be given to this point: in any case, however, proof has already been afforded that gas producers, burning coke, are able to give very satisfactory results, as it is possible to make a very good gas with them, suitable for driving motors—even from small coke containing over 15 per cent of cinders.

To sum up, the working of the plant shown by Messrs. Pierson has been satisfactory in every respect, from the industrial point of view; and although the prize was not awarded it, as the competition still remains open, still the committee were pleased to admit that the constructors had succeeded in making very good gas from coke with their apparatus.

It is reported that the United States Government has placed orders for several motor lifeboats, using 5 H. P. engines.

GAS ENGINE INQUIRIES.

The 1905 "Question Box" of the Ohio Gas Light Association contains a most interesting series of questions relating to gas engines, particularly as regards the standpoint of city gas companies. Of 809 pages devoted to inquiries and answers, the section on gas engines contains 143 pages (17½ per cent), besides which there are pages in other sections relating to power gas and questions of plans to be employed in helping secure the installation of gas engines. It would be impossible to give an idea of even a considerable portion of these questions and answers, but we have selected, almost at random, some inquiries which are of especial interest.

Numerous and varying answers (although almost unanimously in favor of the gas engine) are given in answer to the question, "Which is the cheaper source of power, a gas engine developing 20 B. H. P. for a continuous load for eight hours, with gas at sea level and at a cost of \$1 per thousand, or an electric motor under the same working conditions, with current furnished at five cents (which is the average price in the United States) per K. W. hour?" One reply gives the accompanying table:

	Cost per B. H. P. per hour in cents.	Cost of 20 H. P. for 300 days of 10 hrs.
Electricity	5.00	\$3,000
Gasoline, 20c per gal.	2.95	1,770
Steam, coal \$3.50	2.49	1,494
Gasoline, 15c per gal.	2.33	1,398
City gas, \$1 per M.	2.25	1,350
Crude oil, 5c per gal.	2.10	1,260
Gasoline, 10c per gal.	1.70	1,020
Crude oil, 2c per gal.	1.35	810
Suction producer, coal		
4.25	1.23	738

Depreciation, interest and repairs were figured at 15 per cent of the first cost. Oil, fuel, attendance, etc., were all added in the costs.

"What is the smallest size engine profitable to introduce?" The answers are not at all unanimous; 2 and 3 H. P., and 1 H. P. One answer says none are too small to install with profit. Another says that anything under 1 H. P. gives trouble, while another says a ½ and a ¾ H. P. give excel-

lent results. Still another says a ¾ H. P. has given good results, using 3,000 feet of gas a month.

"What is the largest size engine which, using city gas, can compete with steam or electricity?" This is a question which is being asked more and more every day. One answer states that a certain commercial concern has figured that units of 280 H. P. operated by the city gas were profitable; 30 H. P. is given by another as the limit of profitable gas engine installation, while still another says: "Depends on price of electricity. The largest made always can compete with steam. If a small engine can compete, then a 650 H. P. engine can."

"What are the specifications in viscosity, flash point, chill point and per cent animal, vegetable and mineral matter, for the best oils to lubricate gas engine cylinders?" "Specific gravity 900, viscosity 1.55, flash test 420 degrees F. Oils for this purpose should be pure mineral products, containing no free acid, animal or vegetable matter. Viscosity—referred to water at 172 degrees F., using Scott viscosimeter."

The following instructions are given by one contributor in answer to an inquiry as to whether it is advisable to use compression plates in changing low compression gasoline engines over to gas engines: "It is entirely feasible to increase the compression in a gas engine cylinder by attaching a steel plate to the piston head, provided the following precautions are taken:

"(1) That the plate will lie hard up against the head over its entire surface.

"(2) That the plate is doweled to the head at its center, either by a screw in a reamed hole, or a dowel pin.

"(3) That all screw holes through the plate, except the one in the center, allow a small clearance around the screw shanks.

"(4) That countersunk headed screws are used, the heads riveted over, and the entire back surface of the plate smoothed off after attachment, so that there may be no projections of screw heads and no holes to induce pre-ignitions.

"(5) That all screw holes in the piston head are blind; that is, not drilled through into the piston chamber."

Many people regard as true the statement that a gas engine will explode its

charge with greater force than a make-and-break spark is used than when a jump spark is used, and in answer to this question one eminent gas engine expert answers, "It does not."

Replying to the question as to whether the exhaust gases should not be odorless, since perfect combustion of a hydrocarbon

should produce only water vapor and carbon dioxide, one contributor says: "The gases should be odorless, but, as a matter of fact, they are not, this being due to many causes. The odor of the lubricating oil is one reason; another is that gas is always changing its quality, making it impossible to have perfect combustion at all times."

THE GAS ENGINE IN THE BLACKSMITH SHOP.

Several correspondents of *The Blacksmith and Wheelwright* discuss, in a recent issue, the use of gas and gasoline engines in the blacksmith shop. One, in answer to the question, "Has Power Proved Profitable?" says:

"We are going to tell of our own experience with power as developed in an 8 H. P. gas engine. We have two facilities which many similar shops do not possess, viz, city water and street gas, both supplied under pressure, and the engine is connected with both. We begin to fire up by lighting the gas jet which heats the tube, the explosions being effected by hot tube instead of by sparker, and then do the necessary oiling. In five minutes the tube is cherry red hot. We then open all the drip oil cups, open the valve in the water pipe just a little (the water circulates through the jacket and runs into the sewer), open the gas valve which supplies the explosive, turn the fly-wheels backward one and one-half revolution and away she goes, after which we open the gas valve to the full speed mark. Then no more care, no attention; shut it off when we are through. Of course, we occasionally clean the engine, but that amounts to next to nothing. We think we have pretty near the minimum, so far as care and time to operate are concerned. We have no gasoline tank to fill and carefully watch, lest the supply run out, no water tank to fill and keep full, no batteries and sparker to get out of order, and, of course, no pump on the engine, thus reducing the number of wearing parts and adding to the simplicity of the machine. There is one more convenient feature to which we have already made slight reference. When we wish to draw the water from the jacket, lest it freeze, or for other reasons, we have but to open a valve and an air cock to let the water run into the sewer. An advantage in gas over gasoline is that there are no set

rules to be followed to avoid higher insurance rates. Now, any one who has had experience running any kind of an engine can realize that the personal time spent on our engine is very little. In order to judge whether or not the power has proved justifiable, the reader should know what use has been made of it. The engine is connected with a 24-inch surface planer, a 16-inch buzz planer or jointer, a table saw for ripping or cutting off, a 32-inch band saw, a wood-turning lathe, a small iron turning lathe on which we also run an emery wheel, sand roll, etc., and a band saw.

"Before installing the engine and machinery, if we had much machine wood-work to do we were obliged to load the lumber into a wagon, go to a neighboring factory, pay forty or fifty cents an hour for the work done and stay there to direct it; for in this way only could we get it done as we wanted. Thus you see we were putting in our time and paying forty to fifty cents an hour for what we now do at the expense only of our own time and of running the machinery. So we pocket the difference between at least forty cents an hour and the expense per hour of running. And there is more profit than this in having the power ourselves, for we do the work better in many cases, thus requiring less hand work in finishing. We have the waste wood, shavings and sawdust (these are of more value than an outsider would think); we do many jobs on the machines which we formerly did by hand, in preference to going outside to have them done by machine, and the knowledge by customers of the fact that we have this equipment has increased our business. This is not poetry or fiction, either, for they have learned that we can do their work quickly. We frequently have customers from several miles away come to us early in the morning with all-day jobs, bringing their dinners and staying un-

til the work is done, and they could have had the same work done in their own towns for less money, but they would have lost more money by having their men and horses idle longer waiting for the repairs.

"It may be that some of the readers of this article think an 8 H. P. engine is larger than necessary for our work, but we believe that in the long run it is cheaper to use 6 H. P. from an 8 H. P. engine than from a 6 H. P. engine. We have read many testimonials telling what 2 and 3 H. P. engines are doing, and we do not note that they run two or three machines like surface planers, ripping saws and large band saws. They may tell of running an emery wheel, drill press, triphammer, blower, lathe, etc., all at once, but hitch the little engine to a surface planer and try to plane hardwood lumber from twelve to fifteen inches wide, or soft boards eighteen to twenty-four inches wide, and the testimonials will change character. This kind of work requires considerable power and can be done by small engines only at a loss of time. Do you ask how much we can do with our engine? Nearly every day we

work any two of the machines we happen to need at the same time, and occasionally any three. The engine will easily handle three of the woodworking machines at one time, provided the operators do not crowd. We expect to add to our equipment some time a shaper, a sand drum, a blower, a regular emery grinder, a grindstone and to connect our drill press, and we think the engine will run any half dozen of them at once during ordinary work.

"If we take the liberty to offer a little advice to prospective buyers of power, we would say, do not get too small engines, especially if you propose to do woodwork. Remember that planers and ripping saws require more power than drill presses, blowers and grinders. Another opinion of ours is that it costs less to run two machines one hour than to run one machine two hours. When possible we arrange to have two men working on the machines at the same time, thus making the fuel expense for running one machine only five cents an hour. This we consider a low rate for such machines as surface planers, buzz planers, table saws and band saws."

GASOLINE ENGINES IN CHINA.

By GEORGE E. ANDERSON, U. S. Consul Hangchau

Labor is so cheap in China and the cost of installing a power plant is comparatively so much that there is reluctance on the part of Chinese manufacturers to introduce power, even where it is evident that they could do so with considerable saving of labor and eventually of money. Under the present cheap-labor system of doing things there is no outlay for high-priced machinery, and the result is that if for any reason an establishment is shut down there is no loss to follow the idleness of money invested in a power plant.

The "fung shuey," or doctrine of the "wind spirit" and "good luck" has also a direct bearing upon the situation. It is believed that tall smokestacks and high buildings will interfere with this "wind spirit" and bring bad luck, and it is safe to say that no ordinary attractions of investments will lead the average Chinese businessman into doing anything to conflict with his belief.

There is a growing conviction of the advantage of power plants in the larger con-

cerns, and the number of mills with fair-grade power plants is increasing. It will be only a matter of a short time until the smaller manufacturers come to appreciate the need of power, and when that time comes there will be a field for gasoline engines almost beyond conception in its scope. As in the United States, there will be many cases and places where steam power will be preferable, but there are already many chances for the introduction of gasoline or naphtha power. Such engines are put out cheaply, and can be made cheaply and strongly enough to meet the requirements of a market where there is an absolute lack of knowledge of such machinery and its practical operation.

American manufacturers must remember in this connection that while they have the advantage at the present time, there is reason to believe that before long they will have to fight for this trade with every weapon known to the modern business world. Already Japanese manufacturers are commencing to make some machinery of

this sort, and while it lacks the merit of the American product, and will always be more or less behind the latter, it by no means follows that it will not be readily accepted in China. The Japanese have iron, coal and other raw materials and industrial necessities. They have American and European trained experts, and they have labor so cheap that American competition on a labor basis is impossible. It behooves American manufacturers to get into the market in China with machinery of all kinds if they expect to hold these markets in the future.

The power machinery for most mills in this portion of China is from England or Scotland. As a rule, the mills have been

established with English capital or under English auspices, and, naturally, the machinery has been bought in the United Kingdom. At the present time, other things being equal, American power is likely to be sought for, but where the margin between the machinery of several nations is as narrow as it is, it can hardly be expected that the Chinese market will do much running after the goods of any one of them.

So far as gasoline engines are concerned, a few object lessons out here would do a world of good, and I believe that there will be an immediate demand for such machinery when its cheapness, convenience and efficiency are known.

FOOS GAS ENGINES.

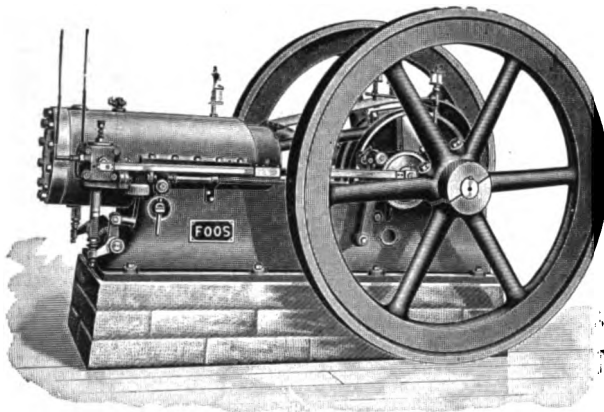

Of the older gas engines manufactured in this country the Foos is probably one of the best known, this having been manufactured at Springfield, Ohio, by the Foos Gas Engine Company since 1887.

From the small shop in which the first Foos engine was turned out, the plant has been steadily developing until the company claims that it is now the largest in the United States devoted exclusively to the manufacture of this type of engine, no side lines or other machinery having been at any time manufactured by that concern.

The business is handled through general agencies, and, as might be anticipated, these are carefully selected and well organized. Agencies are located in all large towns, and nearly all carry a number of engines in stock.

Workmanship and finish have always received special attention in Foos engines. All

valve stems, piston pins, governor spindles, etc., are ground to gauge after being machined, and the use of jigs and templates insures the interchangeability of parts so necessary for satisfactory repair. While the engine itself is built at the present time upon the same general design as originally planned, its details show the advantage of combined development through the years of use under regular conditions of operation.

The general proportion and mechanical lines of the engine have been carefully worked out, giving the impression of unusual strength and substantial construction. One of the leading features of the Foos design is the type of igniter, it being of such design as to enable a wiping action between the electrodes, which necessarily keeps the points clear from any accumulation of foreign matter.

This idea is one of the fundamental patents of the Foos engine, and, too, from the fact that no hot tube igniters are furnished on this engine, it is evident that the electric igniter used must be exceptionally reliable.

A distinctive feature is also found in the method of counterbalancing, this being accomplished by securing discs on the arms of the crank, which, bringing the weights in line with the piston and other parts to be balanced and between the main bearings, relieves greatly the strain encountered in the usual construction. With this arrangement the wheels are, of course, each in balance, no counter weights therein. The main bearings are of phosphor-bronze set at an angle

of 45 degrees. The crankshafts, pins, connecting rods, etc., are all unusually heavy, and it would seem that the engine could not be otherwise than very long lived.

A feature, which is doubtless much appreciated by those having a gas engine experience, is the accessibility of the whole Foos design. The arrangement of parts is such as to enable both the exhaust or inlet valves, any portion of the igniter, connecting rod, etc., to be removed without breaking a

gasket, and any of these parts, the cylinder head, piston rings, etc., can be inspected or removed without disturbing any piping or any other mechanism of the engine.

The engine is built in the regular stationary in sizes from 2 to 80 H. P., special electrics, portable ready for mounting, pumping combinations, portable electric plants and various other special combinations relative to any of which information will be gladly furnished.

DECISION INVOLVING HORSEPOWER.

Where an engine is sold upon a warranty that it is capable of developing 25 H. P. when tested according to a designated system, the Supreme Court of Kansas holds (79 Pacific Reporter, 661) that a finding that there was a breach of such warranty may be sustained by evidence that, in actual use under ordinary conditions, it could not develop more than 15 H. P., even though no test was ever made according to the prescribed method.

Where a contract of warranty under which machinery is sold provides that its continued use for five days without complaint shall be conclusive evidence of the fulfillment of the warranty, the court further holds that a retention of the machinery without complaint for five days after its first use, without actually using it for five days, does not have such effect.

The specific warranty, a breach of which was claimed in the case before the court, was that the engine in question (a gasoline engine) was capable of developing 25 H. P. "when tested by the purchaser by the system for discovering the horse-power of an engine known as the brake test system." This was incorporated in the printed form prepared by the company, upon which the order for the machine was made. There was evidence sufficient to justify a finding that in actual use the engine could not develop the specified horse-power. But no test was ever made by the purchaser according to the system prescribed in the contract of warranty. It was contended by the company that the capacity of the engine must be determined by the very test stipulated for it; that to sustain his claim of a breach of this warranty, the purchaser was required to show the application of such test, and the failure of the engine to develop the

required power when measured in this manner.

With this contention the court does not agree. It says that it was but just to assume, as against the company, that, whatever may have been the peculiarities of the test described in the contract, it proceeded upon some correct principle, and afforded a means for determining with reasonable accuracy the capacity of the engine under the ordinary conditions of actual use. To indulge in any other presumption would be to permit the company to perpetuate a manifest fraud. There was evidence that the engine, when operated by agents of the company under conditions apparently satisfactory to them, failed to develop more than 15 H. P. There was some evidence that it could not develop 25 H. P., measured by any fair method, and the company could not be heard to say that the method it proposed was an unfair one.

The contract also contained this provision: "Seventy-four degrees gasoline is the grade upon which our warranty is based." The gasoline used upon the trial of the engine was of a grade described as seventy-two degrees. It was argued that a test made with an inferior quality of gasoline was not binding upon the company. The court declares that it was a sufficient answer to say that there was competent evidence from which it could have been found that the difference between the two grades of gasoline mentioned was inconsiderable, so far as concerned the operation of the engine, and also that an authorized agent of the company waived the requirement.

The contract contained a provision that continued use of the engine for five days without complaint being made direct to the company at its factory by registered letter

should be sufficient evidence that the warranty was fulfilled. Use of the engine was begun July 3. No notice of dissatisfaction with its operation was given until July 9. It was claimed that these facts precluded a recovery by the purchaser. It did not appear, however, the court says, that the engine was used continuously from July 3 to July 9, or that it was used for more than three days during that time. It was the continued use of the engine for five days without complaint that was to conclude the purchase, not its retention for five days from the time it was first used.

The note was executed July 13, after the

trial of the engine, being payable October 1. The company sought to give to this transaction the effect of a final acceptance of the engine. But the court says that it was not capable of that interpretation. The original contract of purchase called for a note to be given, to be due October 1, and provided that, if such a note were not given, the contract itself should stand as a written obligation to make payment at that time. The mere delivery of the note made no change in the relation of the parties, one way or the other, and no circumstances were shown tending to give it the effect claimed.—*Farm Implement News*.

WHAT SHOULD HE HAVE PAID?

Under this heading *Power* recently published a statement of a case where a man bought a gas engine that was rated by the seller as 75 H. P. He represented that it could be run for \$20 per month, running 24 hours per day, and carrying the load the buyer had for it. This load the buyer was led to believe was very near the full capacity of the engine. The price was to be \$1,600, and the strong inducement to buy was the alleged economy, as it was to replace a steam engine and boiler. The buyer was not posted on gas engines, but he figured out a good profit, *if the engine would do as represented*. Of this he had such doubts as to lead him to hesitate, but he finally closed the deal under a written guarantee that contained a proviso that if the gas consumption was above \$20 per month the price of the engine was to be reduced in proportion as the cost of the gas increased. The gas used was natural gas, of a heat value of about 1,100 B. T. U., and cost 18 cents per 1,000.

After the engine had been duly installed and was working it was found that the gas bill went up to \$43 per month, and the question of the price to be paid under the guarantee became a very live one, and one which there seemed to be a very wide difference of opinion on. After figuring all around the question, and having a number of others figure for him, the buyer of the engine sent in a bill of \$96 to the maker of the engine. This he thought would be a proper settlement under the guarantee; he, of course, to also keep the engine, on which he had not made any payment.

He admitted that this conclusion was

reached by taking the construction and figures that were most favorable to himself, and was rather more favorable than he really expected the final settlement would be.

The writer of the article offered the suggestion of the proportion $43 : 20 :: 1600 : X$, but said that this solution was not satisfactory, for if the gas bill went high enough, the engine would be a loss as a gift, in which case X should be a negative quantity, which it would never become by this proportion.

Louis Illmer, Jr., in replying to the article in question in *May Power*, says:

"The article as published is to a large extent unfair to the gas engine. The guarantee for fuel charges of \$20 per month for continuous operation of a 75 H. P. engine on natural gas is evidently based upon a fuel economy of 10,000 B. T. U. per B. H. P. per hour, a figure which is reached in the better types of large engines. From the actual gas bill of \$43 per month, it would appear that the gas consumption was about twice the above value, which corresponds to an efficiency at the brake of about 12 per cent. This is an exceedingly poor showing for a gas engine, but is still as good as the best of large-sized steam engines. An ordinary steam plant of 75 H. P. would have a net efficiency of about 3 to 4 per cent, and the corresponding fuel charges would be considerably over \$100 per month. If this difference does not represent the actual saving in changing from steam to gas, it simply casts additional reflection upon the design of this particular gas engine.

THE GASOLINE ENGINE AND THE CIRCUS.

We have heard the question occasionally, "What kind of machinery will the gas or gasoline engine operate?" About the best answer we have ever heard was, "Anything."

The accompanying illustration shows how the gasoline engine has invaded the circus in a new way. When we were boys and watched the circus come to town, driving stakes was one of the things we all felt we did not care to do, however much we might enjoy being one of the wonderful persons associated with "Barnum's." The outfit illustrated is a stake driver, operated by compressed air, the compressor being driven by a gasoline engine. The stake driver is not shown in the illustration, but the rear portion of the truck shows the space usually occupied by it.

The outfit includes a complete compressed air cleaning outfit, which will be used for cleaning and disinfecting in the same manner as the portable outfits which are to be seen on the streets of all large cities nowadays. This portion of the outfit consists of a carpet and rug cleaner, furniture clean-

er, costume cleaner, cleaners for horses and other animals, disinfecting apparatus and other general cleaning devices.

The gasoline engine is 8 by 12 inches in cylinder dimensions; it runs at 225 r.p.m. and is water cooled. The air cylinder has a capacity of $74\frac{1}{2}$ cubic feet of free air per minute at 75 pounds pressure. The suction air cylinder is 3 inches and the air discharge $2\frac{1}{2}$ inches. The length of the engine bed plate is 7 feet, the width $2\frac{1}{2}$ feet and the fly wheels are 36 inches in diameter. The weight of engine and air compressor unmounted is 2,300 pounds, while the mounted outfit weighs about 5,000 pounds.

The machine was built by the General Compressed Air Company, 3933 Olive street, St. Louis, Mo. This company is engaged in the manufacture of special gas engine driven air compressors of all kinds, and also makes a specialty of compressed air cleaning plants, both stationary and portable, under the patents of Mr. J. S. Thurman, who is president and general manager of the company.

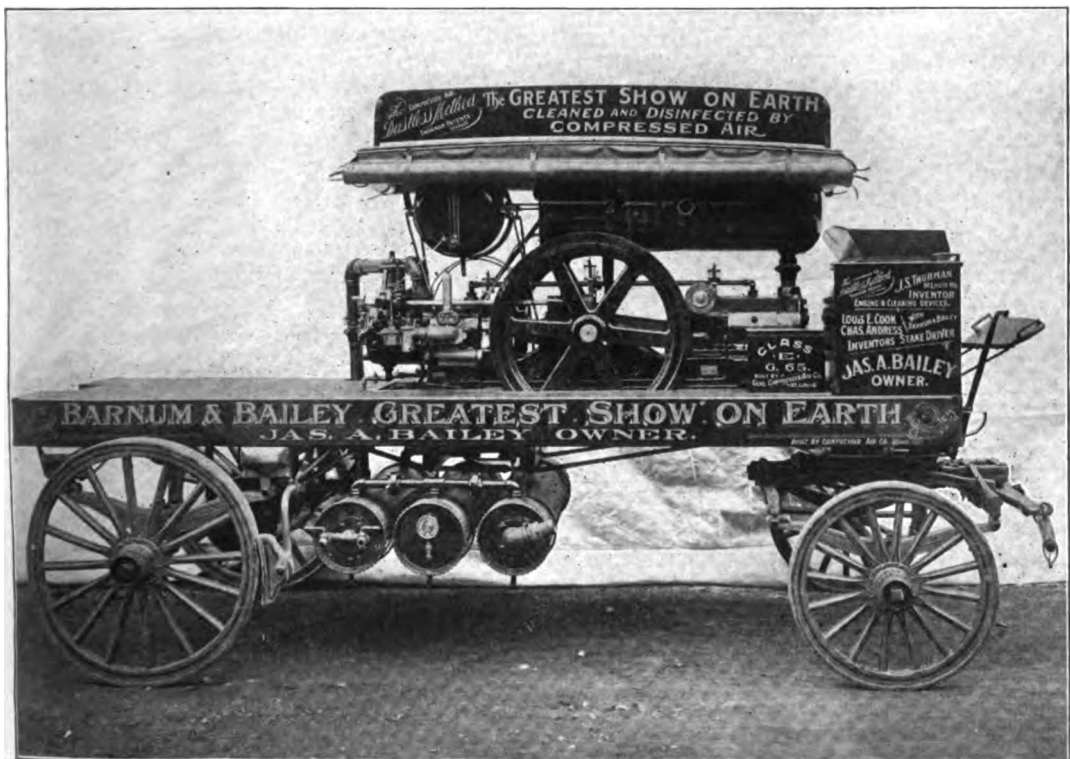

ANSWERS TO INQUIRIES.

It is our purpose to answer in this column inquiries of general interest which relate to the gas engine or its accessories. The questions will be answered in these columns only, and we reserve the privilege of refusing to answer any question which is not, in our judgment, of interest to the subscribers of THE GAS ENGINE.

All matter intended for this department should be addressed to The Editor of THE GAS ENGINE, Blymyer Building, Cincinnati, Ohio. The name and address of the sender must accompany the inquiry in all cases as evidence of good faith. The initials only of the sender will be published, together with the postoffice and state.

Write on one side of the paper only, and make all sketches and drawings on a separate sheet. Mark each sheet with the name and the address of the sender.

In sending in inquiries for this department, correspondents should always state whether two or four cycle engines are referred to. Many times the editor has no light as to this, and must assume one or the other to be referred to.

(a) When the explosion occurs in a gas engine and on the whole expansion stroke, does the pressure force the cylinder rings ahead of it, or does the piston pull the rings? (b) If rings fit good and cylinder is true, would engine leak much if piston would be worn much? (c) How many square inches radiating surface to the H. P. are required with fan?—P. A. J., Cambridge, Ill.

(a) The rings are usually drawn by the piston when the engine is new. If much worn the rings may push slightly. (b) It is best to have a good fit on the piston, but with rings that fit well there will be little

leaking, even with a loose piston. (c) 1,000 square inches per H. P. for radiator of the coil type; 500 square inches per H. P. for a radiator of the honeycomb type. For an air coiled engine it is customary to supply fins, of a length equal to about 1-3 the cylinder diameter and as many as practicable.

I am going to build a four-cycle engine with two cylinders two-inch bore by six-inch stroke. (a) Would this engine have as much power as a single cylinder engine of the same stroke, but with a bore of four inches? The engine is to drive a runabout to seat two people. (b) What size clutch should be used? (c) What form of ignition should be employed? (d) What should be the weight of the flywheel? (e) Will 1¼-inch crank be large enough? (f) Should the cranks be opposite?—W. B. Chicora, Pa.

(a) No, not over one-half as much. 2 inches by 6 inches is a poor proportion. (b) For the 4 x 6 inch engine, single cylinder, about 10 inches diameter. (c) Jump spark (d) about 20 inches diameter, 100 lb. in rim. (e) No, use about 1¾ inch diameter. (f) For a two-cycle engine or an opposed four-cycle, yes. For a vertical four-cycle, the cranks should be together.

Am building a gas engine 3¼ inch bore by 4¼ inch stroke. (a) What power will this develop at 500 r.p.m.? (b) Are 1 inch inlet and 1¼ inch outlet large enough? (c) How much space for compression is required? (d) Should there be a regulating valve on the inlet? C. A., Lyman, Pa.

A four-cycle engine is assumed. (a) 2 H. P. (b) Yes. (c) 15½ cubic inches. (d) There should be a throttle between the inlet and the vaporizer.

SOME IGNITION QUERIES.

Did it ever occur to you that every time your engine misses fire, a charge of gas or gasoline has been wasted?

Did you know that eight hours short-circuit will ruin any set of dry batteries, and do almost as much damage to liquid batteries?

Did you ever figure how many hours your machinery was shut down in a year,

just because you failed to keep your ignition system in perfect condition? And did you ever figure how much money those wasted hours means?

Did you ever think how much less fuel you would use in a year, and how much more power the engine would give on a given amount of fuel, providing the ignition is properly timed?

POWER GAS.

Dr. F. H. Bowman recently delivered a lecture before the Leeds Section of the British Institute of Electrical Engineers, discussing the subject of producer gas for power service. After calling attention to the great advances that have been made in the production of power by gas engines, and after briefly taking up some of the elementary information on the laws of gasification, the speaker referred to two factors which determine the nature of the producer plant to be employed in meeting gas engine requirements. These factors are the size of the plant and the fuel available, and the character of the locality and the space available.

The size of the plant is, of course, important, because it will determine whether it will pay to use bituminous or non-bituminous fuel. For small plants anthracite or coke is much the best. They may be used in pressure or suction producers, whereas bituminous fuels can only be used in the former. Presuming, said the speaker, that the power required is in units of not less than 500 B. H. P. each, it will pay to use either, but the plant for non-bituminous fuel is so much simpler, and requires so much less attention, that it is often much better to use such fuel, even when costing more per ton than bituminous fuel. Where the works are apart from residences and amid large manufacturing premises, where smoke and fumes are so prevalent that only a small increase in quantity will make no difference, bituminous plants may be used. When, however, it is desirable to avoid even the appearance of a nuisance, then anthracite or coke, and preferably the former, must be employed.

The space available also must be taken into consideration, and especially in large and crowded centers of population, where ground is costly and every available square foot is necessary for the generating machinery. Bituminous plants always require more space than non-bituminous, because it is necessary to have a large space occupied by the condensing and purifying plant; and in case of the recovery of residuals, a more complicated plant still, which not only requires a large area but can not be confined within an enclosed building. In addition, also, as all bituminous plants are pressure

plants, there is the necessity for large gas-holders, unless the gas is consumed as rapidly as generated. Even in this case there is usually a small gasholder required to equalize the composition of the gas, which varies considerably from time to time, and also to give a more constant pressure. Non-bituminous plants occupy much less space and need little purifying arrangements; but, of course, when of the pressure form, there is the necessity for at any rate a small gasholder, as though they can be regulated in the production of the gas just as it may be required, in a manner which is impossible in a bituminous plant, still there must be some storage provided, or gas would have to be from time to time turned out into the air and cause a loss in the economy of working.

Considering the forms of producers applicable to central stations, Dr. Bowman divided them into two classes: Pressure plants, where the air and steam are forced into the producer by means of a blowing engine, a fan or other form of blower, or a steam-jet. Pressure plant may be either: (1) For use with bituminous fuel; (2) for use with anthracite or other non-bituminous fuel, such as coke. Suction plant can only use non-bituminous fuel, like anthracite or coke.

Up to the present time, the 1,000 B. H. P. gas engine seems to be the largest practical and economic unit which can be taken from one cylinder even when double-acting; but multiple cylinder engines are being made from which a larger power may be obtained, and two or even four engines may be coupled so as to obtain a larger unit. Pressure plant with bituminous fuel may be used for these large units because they will generally be placed where there is sufficient space, and where bituminous fuel can be obtained cheap. It will pay also in this case to use recovery plant, and the sale of the residuals will in this country, probably for some time, go a long way in the reduction of the price of the gas and diminish the greater expense arising from the outlay of capital and expense of working. They are not, however, advisable for intermediate sized plant, and ought not to be put down for any size under 1000 B. H. P. Where units of above 2000 B. H. P. are required in

one machine, up to the present time steam is to be preferred to gas; but, of course, with gas units of 2000 B. H. P., any sized power station can be constructed, and no increase in size would give increased economy. Of these plants it is only necessary to mention the Wilson, Mond, Duff-Whitfield and Dynamic bituminous plant. It must be remembered that in all these cases it is not every kind of bituminous slack which can be used. Only free burning non-caking coal is suitable for use in producers such as that which pertains in the northern part of the Nottingham coal fields, centered round Linby. Most of both the Lancashire and Yorkshire coal is unsuitable; and the writer knows of several cases where great disappointment has arisen, as the local coal was not available, and the increased cost of bringing the suitable coal from a long distance—such as from Nottingham into East Lancashire—considerably increased the cost of production. With a good bituminous plant and recovery of residuals and a modern gas engine developing 1000 B. H. P. on a full load, a B. H. P. can be produced at a cost of under .4-cent per hour, including everything. With a pressure plant such as a Dowson, using anthracite or coke, a B. H. P. may be obtained, including everything, for about .9-cent per hour. Besides Dowson, there are many makers of non-bituminous pressure plants, such as Crossley, Tangyes, Fielding and Platt, Paisley and Welsh, Daniels and the Dynamic Gas Company. Anthracite and coke may be mixed, or the latter used separately as the fuel; but in this case the producer must be of greater capacity and provision must be made in the cooling and purifying of the gas to arrest the sulphur which is always present in the coke, and extra cleaning is required.

The best results known to the author on a 1000 B. H. P. power steam plant give .66 cent per B. H. P., including everything. All pressure plants, however, have one disadvantage—they require power to produce the blast necessary to force the air and steam through the system; and they require storage for the gas unless the requirements are perfectly uniform, which is never the case, when the gas is used for power purposes. They require also a separate steam supply; and experiments have proved that when the best results are attained, about 16 per cent of the total fuel used is consumed to generate this steam. Another disadvantage of this form of producer is that the gas being

under pressure, there is a liability to leakage; and as the gas has no smell and is of a highly poisonous character, serious accidents have happened. Pressure plants are quite unsuited to confined spaces. Whatever form of producer is used, as the gas is of less calorific power than city gas, a larger engine is required for the same power. The difference ought not to be taken at less than 20 to 25 per cent, but better results are frequently obtained.

In 1888 M. Benier, a Frenchman, conceived the idea that these disadvantages might be overcome by arranging a closed producer in such a manner that the air might be sucked through the producer by a suitable pump, instead of forced into it by means of the steam-jet, and that the gas thus aspirated might be delivered stroke by stroke to the engine as and when generated, and thus do away with the necessity for using a gasholder. Also that the aspiration of the pump would produce a slight vacuum in the producer and scrubber; and thus the waste heat when cooling down the gas could be utilized in an open boiler to generate the steam necessary to be mixed with the incoming air so as to enrich the gas with the necessary hydrogen. This principle he put into practice about 1889; but from various causes it did not come into extensive use either in this country or on the Continent, where, however, several trial plants were installed. In continuing his experiments, Benier himself found that a separate pump was unnecessary, as the suction of the piston of the engine in its outward stroke was sufficient to draw the gas through the system.

Up to 1901, however, this form of producer was scarcely used in this country, partly on account of the general cheapness of gas; but principally in consequence of certain defects which were common to all the existing forms. The correct regulation of the steam to the air supply and the control of the fire while the producer was in operation was not provided for; while the exact proportions between the area of the fire and the heating surface of the boiler and the relations of these to each other and to the temperature of the furnace, and the relation of the whole to the size and speed of the engine was not understood. In making researches into the most economical sources of power for commercial purposes, the inventors of the Dynamic gas producer came to the conclusion that if these relations

could be determined, all difficulties in the use of suction producers would be overcome. Their endeavor was to exactly coordinate the producer and engine to each other so that the latter should have the complete control of the former. In this respect they have been entirely successful; so much so, that a large unit has been run for weeks continuously night and day with a regularity quite equal to the very best steam plan.

The composition of the gas from a "Dynamic" producer is practically the same as produced in a pressure plant using non-bituminous fuel; but it is much more regular, and the calorific value can go as high as 155 B. T. U. Its average value is about 150 B. T. U.—being a mixture of producer and water gas. The engine and producer, however, in this suction plant being exactly suitable to each other, the engine has absolute control—not only of the quantity, but also the quality, of the gas, and the regularity in the composition much exceeds that from any pressure plant. Analysis of the gas taken from a Dynamic gas-producer, even when running on an irregular load, showed no variation exceeding from 148 to 155 B. T. U., and samples taken at regular intervals during many hours showed a regular average of about 42 per cent of combustible matter. The producers can be made to drive any power required, and for which gas engines can be made, and under suitable conditions more than one engine or a multi-cylinder engine can be driven from the same producer.

The one disadvantage of a suction gas-producer is that it can not be worked on an absolutely light load for any length of time,

because when no air or an insufficient quantity of air is drawn into the producer, the temperature of the fuel falls, and so at least it is reduced to the point that good gas is not produced. This is especially the case in plants where the volume of incandescent fuel is only small. The limit of satisfactory working on light load seems to be about one-fifth of the total load. A 50 B. H. P. engine will not work for long under 10 B. H. P. In large units where there is a greater reserve of heat, the elasticity is greater, and no difficulty is experienced in taking off or putting on a large proportion of the load without any variation in the running.

If a comparison is made between a gas engine using city gas, and the same engine with suction producer gas, the results are very remarkable, and differ, of course with the cost of the city gas and the anthracite. A plant recently put down at the works of the Weldrivet Boiler and Motor Company, Limited, of Halifax, drives a 60 B. H. P. gas engine, and the power which is, on the average, about 30 to 40 B. H. P. is distributed electrically. The cost per week of 54 hours with gas at 54 cents per 1000 cubic feet was about \$19.32 per week. Since the suction plant has been put in, the cost of the anthracite coal has not exceeded \$3.36 per week, or rather less than .2 cent per B. H. P.

Some results of tests (in which the cost of fuel only, with coal at \$7.68 per ton, came out at .286 cent per B. H. P.) are given of a small plant at the experimental station of the Dynamic Gas Company; and it is noted that since they were made, by the use of a special mixture of fuel, the cost of fuel per I. H. P. has been reduced, the author states, to under .15 cent on a two days' test.

BOOK REVIEWS.

The Automobile Handbook, by L. Elliott Brooks, 16 mo, 4x6½, 320 pages, illustrated, bound in limp leather at \$1.50, or full red morocco with gilt edges at \$2.

This book is compiled in the form of an encyclopedia, the various subjects being put in alphabetical order. This does away with the necessity of an index, but renders continuous reading rather jerky.

The construction, care and operation of gasoline and electric automobiles, their parts, etc., the troubles likely to be encountered, etc., are covered in more or less de-

tail. Tables of machine and cap screw dimensions, areas of circles, etc., are included. In the main the work is well written, handy for reference, and accurate, but there are a few exceptions. For instance, under the heading of the "Relation of Horsepower to Bore and Stroke," the statement is made that "the horsepower of a gasoline motor when the explosive charge and degree of compression are at their best, depends entirely on the piston displacement or the volume swept out by the piston and the number of revolutions made by the motor." This

leaves entirely out of question the ignition of the charge, or the time of ignition, which determine very largely the amount of power developed by the motor. The author's remarks on ignition timing show that the omission referred to has been merely an oversight.

The novice in automobile matters will find much instruction and good advice in this handbook, and even the experienced automobilist may read it with considerable profit.

Producer Gas, by A. H. Sexton, 220 pages, cloth, Manchester, 1904, \$4.

This work by the professor of metallurgy in the Glasgow and West of Scotland Technical College, is intended as a sketch of the properties, manufacture and uses of

gasoline fuel. The American designer of gas producers is extremely interested in learning what has been accomplished in Europe in this connection. This book is excellently suited to his purpose. It begins with a chapter on the constituents of fuel gas and describes the chemical and physical attributes of these various gases. The efficiency of gas producers and the various types are subjects then considered. Conditions which must be fulfilled by good producers is a particularly instructive chapter. The various uses to which gaseous fuel may be put, including the generation of power by gas engines, are taken up, but the work does not enter extensively into the subject of gas producers especially for gas engines nor are the particular requirements of gas engine gas producers covered.

PRODUCER GAS UNITS.

The practical utility of producer gas by power companies has been greatly stimulated in the past year or two by the development of individual gas generating units that are readily adapted to various commercial uses. The operation of the gas engine on city gas has its limitations. For small industrial purposes requiring engines no larger than 25 H. P., city gas proves a most economical fuel; but above this size the cost of operation rapidly increases, and the profitable employment of large gas units on city gas is practically prohibited. The economy in the first place is due to the difference in the cost of labor. Owing to its automatic operation, the small gas engine can be trusted to an ordinarily intelligent employee, and the saving in the salary of an engineer more than compensates for the high cost of city gas as fuel. The extension of the gas engine has, therefore, been dependent upon the production of a cheaper form of gas. The standard gas engines will deliver a B. H. P. for each 12,500 B. T. U. The difference in the quality of the fuel does not materially affect this result, and gas from the blast furnace, which is particularly poor and low in quality, will produce as effective power as the best city gas in proportion to the number of the thermal units supplied. In order to utilize the cheaper grades of gas, the engines simply had to be constructed with a capacity for handling a larger quantity of gas.

Producer gas generating units have steadily improved, and their services have been demonstrated abroad and in this country in numerous ways. The combination of the producer gas generating plant and gas engine for burning the fuel form compact and excellent types of modern improved power machinery. The continuous and satisfactory operation of such combinations have recently given a much wider range of usefulness to this form of fuel. The question of economy of installation and operation in comparison with a steam plant is one that attracts the attention of the engineer. The gas producers have the advantage of being able to utilize a cheaper grade of coal, and they can be depended upon ordinarily to furnish one B. H. P. hour from one and a quarter pounds of anthracite pea coal. This form of coal is considered the best for the average gas producer, but almost any grade or quality of fuel can be utilized. Manufacturers of gas producers endeavor to adapt the plants to either anthracite or bituminous coal, although unless there is a difference in the cost of coal the use of hard coal is always more economical. The difference in the cost of using the two fuels is caused by the great amount of hydrocarbons found in the soft coal. In order to prevent the hydrocarbons from condensing in the form of tar and gum in the engines, mechanical washers have to be installed in the producer plant, and the expense of this

increases the initial cost of installation and operation. However, there are many manufacturing regions where the scarcity and high cost of anthracite coal makes it imperative that bituminous coals be used, and the modern producer gas plants must be adapted to them.

Gas engines of 1,000 H. P. and upward are designed today in this country for operation on producer gas, and the running of the larger units on cheaper grades of gas has fully demonstrated their value in certain industrial fields. Wherever coal and water are available, the producer gas plant can be installed in any suitable size. Whether intended to operate engines for driving electrical generating machinery, or for driving direct-belt or geared machinery of a factory or mill, the gas engine deriving its fuel directly from the modern gas producer proves an important and economical factor in the industrial world.

For metallurgical purposes the gas producer and engine have received the unqualified endorsement of mining and experimental companies. The highest temperatures required for economical and perfect annealing are easily obtained in this way. In this particular field the combination unit of producer and gas engine has attained a degree of proficiency that is rapidly causing its general adoption. Its compactness, simplicity of construction and operation, and the high temperatures quickly obtained, recommend the gas producer for metallurgical operations, especially where power machinery is also required in connection with excessive heat.

But after all, this field is only a very small part of the industrial work that the gas engine and producer is called upon to perform. The different forms and modifications of producers have, to some extent, caused a slight confusion in the minds of some. In the effort to refine the gas so that its calorific value will be higher, the cost of production has been increased. The fact seems apparent today that a sacrifice of refinement may often result in actual economy of operation. Simplicity of design and operation is more to be desired than costly, bulky and complicated machinery for refining the gas or for recovering the by-products. A simple and easily adaptable producer for power purposes alone appears to be the demand today.

In the Morgan producer automatic feeding of fuel eliminates some of the former

problems which made cheap gas production on a small or large scale difficult and expensive. In many of the old types of producers, the feeding was carried on at irregular intervals, and the coal was dumped in large quantities into the fuel bed. This fresh coal falling upon the incandescent bed immediately caused a great rush of gases at comparatively low temperatures. The result of this was a considerable loss of fuel and efficiency, and particularly so when a period of very lean gases followed. In order to secure perfection and uniformity of work, the fuel must be fed with automatic regularity, which keeps the rush of gases at a high temperature normally regular throughout every hour of the day. The automatic feeding of the American type of producer has accomplished such satisfactory results that it has been adopted abroad in a number of instances. In England the cupola type of gas producer developed by Mr. Thwaite has sought to reach this same end in another way, and it has received a good deal of popularity abroad. It is reported that in the Thwaite cupola type the combustion or gassification of the fuel is complete, and also in the Duff-Whitfield type.

In the American Morgan type of producer, the coal is dumped into an upper reservoir from whence it falls automatically through an inclined spout to slowly revolving discs. The fuel is thus allowed to work through gradually, and the coal is uniformly distributed throughout. Water seals have to be provided to prevent the revolving part of the producer from leaking so the gas can not escape.

A Korting blower with steam jet supplies the air blast to keep the fuel in an incandescent state. The jet of steam passes through the lower bed of ashes, and serves to reduce the clinkers and absorbs a large proportion of the heat of combustion. The result of this latter process of breaking up the heat of combustion into oxygen and hydrogen, so that the oxygen thus freed can more readily combine with the carbon.

The gas from such a producer is supplied in immense volume, each pound of coal yielding from 65 to 75 cubic feet. This volume of gas, however, is not all immediately available for engine purposes. About half of it is nitrogen, and this carries no combustive energy because it is too heated. The recovery of this waste heat for raising steam has been one of the questions involved in the development of the gas producer. In

the Dellwick-Fleisher water gas producer from 15 to 20 per cent of the total fuel used is said to be utilized through the recovery of waste heat.

The removal of the ashes and clinkers in the gas producer is an important item of trouble and expense. Where the air blast is accompanied by a steam jet this is greatly simplified, for steam coming in contact with clinkers in the hot zone soften and break them so they gradually descend. Easy access is had to every part of the water basin in which the Morgan type of gas producer stands, and the ashes falling here are conveniently removed. The soft, wet ashes can be taken out with little difficulty at certain intervals, and the fire itself can be partly regulated by digging them out or permitting them to remain.

Engineers are tolerably familiar with gas engines of small and large units today, and their perfect operation has made them of general use; but the combination gas producer and gas engine has introduced some new problems in the subject. This is particularly true in making estimates of the plant required to operate electrical generators or other machinery. The gas engines have no overload capacity, such as the steam engine, and in making preliminary estimates the total or maximum of power needed must first be carefully ascertained. In designing a steam engine or electric dynamo, the overload capacity always leaves a margin of safety that figures prominently in the original estimates. This factor, however, must be entirely eliminated when the gas engine and producer are considered.

The other problem that requires satisfactory solution before estimates are requested or designs made is the nature of the fuel to be used. An exhaustive study of this question at the beginning insures satisfactory returns in the end. It may not always be the cheapest fuel, but it is always the fuel that will give the highest returns for a given expenditure. An engine, designed for a low grade gas can never give the highest results on gas of a much richer quality. In designing the producer, the question of the grade of coal to be used must be considered along with the quality of the gas to be produced. With several types of gas producers designed and adapted to different needs, it is not difficult to find a satisfactory solution of these questions. The cost of the producer and engine will vary considerably, according to the grade of fuel

to be employed, and generally the cheaper that the fuel is the more expensive is the initial construction of the plant. A producer adapted to hard coal is thus much less expensive to construct than another built for utilizing bituminous coal. On the other hand, gas producers for soft coal have been built at a slight increase over those for hard coal, and their economy of operation and efficiency have proved eminently satisfactory.

The cost of removing the hydrocarbons in the gas by washers varies considerably. The condensing of the tar and gum in the gas engine is one of the worst troubles that can happen. This is sure to occur from producer gas made of soft coal fed to plants not provided with mechanical washers. A great many devices have been employed to break up and destroy the tar. The formation of this tar occurs under certain temperatures, and if slightly changed it can sometimes be broken up into permanent gases. Excessive temperatures will furthermore disintegrate the tar and cause it to be deposited in the form of lamp-black.

Gas scrubbing and cleaning devices have developed gradually into the centrifugal scrubbers, which apparently give the best results; but they have not yet reached the point of perfection when low grades of soft coal are used as fuel.

For an electrical central station, the gas producer and engine possesses advantages under certain conditions over steam, but the cost of installation of the complete producer plant must be much less than that of a boiler plant to secure economical results. It is for this reason that simplicity of design, with little attempt at refinements to produce a higher grade of gas, is essential to success in the industrial field. With this question properly settled, the gas producer and engine gives better results on light loads, showing a considerably higher efficiency than a steam engine of the same size. Quick starting of the gas engine is always a point in its favor, and also the ease of extending equipment. The cost of maintenance is generally in favor of the gas engine, and the less number of parts required is also a factor of economy in making repairs. The use of the waste heat in the jacket water is sometimes of importance in heating buildings, but this is a factor that can not always be depended upon. However, its consideration in the final comparison of the two systems may in a few cases

prove the determining factor. As soon as a gas engine is shut down all heat loss ceases, but to secure this in the combination of gas engine and producer, storage tanks for the gas must be provided. The con-

tinuous operation of the producer night and day proves the most economical, and to shut this down whenever the gas engine is thrown out of service causes a loss.—*The Canadian Engineer.*

WEIGHT AND SPEED OF THE GAS ENGINE.

There is a tendency with stationary gas engine builders, to follow the head of the automobile motor builders in decreasing the weight and increasing the speed of their engines. We think this is admissible as well as desirable. Many of the stationary gasoline engines up to this time have been unnecessarily heavy and the speed too slow to give the best results both in regulation and power development. The great weight was originally thought necessary to add strength to the parts as well as to aid in holding the engine firmly to its base. It was not uncommon in the past to find engines of two H. P. capacity weighing from 1,500 to 2,500 pounds. We now know of stationary engines of 4 and 5 H. P. capacity giving better satisfaction and doing better work the entire weight of which do not exceed 800 pounds. So long as the heavier weights were maintained less attention was paid to the proper balancing of the gas engine. And the engine being out of balance the power forces operating against a slow speed piston and the unbalanced condition of piston connecting rod, crank shaft, etc., naturally caused a heavier strain on the various parts. The fly wheels on some of the earlier engines were extremely heavy. Moving at a comparatively slow speed they received a perceptible thrust at each explosion impulse which caused a heavy strain on the crank shaft and hub of the wheel as well as on all of the crank shaft boxes and engine frame. It is easy to see how the strain on a higher speed or faster moving piston would be much less and especially so if the reciprocating parts were lighter in weight and well balanced. A heavy engine with all its moving parts proportionately heavy is a power killer within itself. And if it is the least bit out of balance, I am tempted to say, it is doubly so. Weight and slow speeds have been the rules to follow by stationary engine builders. But now come the other extremities, most of them of visionary automobile motor builders, who talk about attaining speeds of 2,500 to 3,000 per minute.

I recall a conversation which I had with a man who has been pretty closely connected with gas engine building for the last dozen of years, which well expresses the ideas some enthusiasts harbor. This person had built a number of stationary gas engines of different designs and construction and concluded that the automobile field needed him badly. He felt that no one had yet really succeeded in building an automobile motor, and that it remained for him to accomplish the feat and at it he went. At the time of our conversation he had just succeeded in getting his new motor to moter for the first time. In telling me of it he said: "Oh, it showed up mighty fine, it ran up to 2,500 r.p.m. the first time." Just as if he expected it to double that speed the second time. When he asked me "what I thought of that," the answer that "I thought it was foolishness to begin with," escaped me almost before I could gather my thoughts for a more conservative answer. His progress with it since that time has proven the answer about the correct one. There are very few automobile motors that are operated at a speed beyond 1,000 or 1,200 per minute, unless possibly it is some of the racing machines. It is also a well-known fact that all the high speed motors are quite light, or comparatively so, in weight. And many of the automobile motors are of the balanced type, by the use of more than one cylinder, quite a few of the opposed cylinder type which at once insures a perfectly balanced engine. Much may be done in balancing the single cylinder engine so as to reduce the strain and hindrance to power development. I was told, only two days ago, by a man who purchased an engine of me more than a year ago, that the engine was located on the third floor of a building, and was so well balanced that it is running now without being fastened with nuts to the anchor bolts. Conservatively speaking, I believe that a reduction of 25 per cent in the average weight of stationary engines of the present time with at least a 25 per cent in-

crease in speed will be an improvement in general. These changes, of course, would call for increased valve areas and careful attention to balancing. I do not wish to convey the idea that a greater reduction in weight and a higher percentage of increase in speed would not be admissible or advantageous. But I believe the above suggestions concerning weight and speed entirely within the bounds of safety and reason, and if adopted might lead on to further development and improvement along these lines. I can not but believe, and, in fact, am entirely convinced, that the portable gasoline engines of the present day are heavy, bunglesome, inefficient, unsightly things in comparison to what we will see ten years hence. I refer to the portable engines as shown at our agricultural fairs and which are sold to the agriculturist for threshing, shredding, grinding purposes etc. The multiple cylinder will take the place of the single cylinder, much lighter in weight, neater in appearance, better balanced, higher in speed and greater in power capacity. Not only are advantages in im-

provements gained by decreasing the weight, but advantages in construction, hauling and shipping. It may not cheapen the cost of the engine, but it will enable the manufacturer to apply the cost of extra weight which he has taken out, to better workmanship and mechanical construction. And there is always room for improvement in workmanship, design and construction. An engine 25 per cent lighter could be handled in loading, unloading and installing with much less risk of damage, and with less help. One fourth of the freight charges could be saved in transportation. I wish to emphasize the fact that many stationary and portable engines now in use are entirely too heavy for the power that they deliver. Not a few of them have metal enough to make two engines, each of equal power capacity and lasting qualities. I would advise against the automobile motor extreme for stationary engines, but believe that the quicker we can get away from the massive construction and slow speed of the past the better we will serve the industry

—*Canadian Implement and Vehicle Trade.*

PICKING COTTON BY GASOLINE ENGINE.

A new cotton picker has appeared in the South. The only real cotton picker in the South thus far has been the darky. He has done the work for nearly two centuries, with more or less satisfaction and at starving expense, depending upon the individual characteristics of a not too reliable character. For years a mechanical instrument that would take the place of the darky and do his work with more rapidity and less mental suffering on the part of the overseer has been the dream of inventors. Such machines have been reported as successful, and when exhibited in Northern cities have seemed to work like a charm. They have drawn cotton from heaps on the floor, and ripe cotton from bolls held to them with accuracy and despatch—also money from the pockets of would-be stockholders. But when taken to the fields and put to work they have always been found to have a colored gentleman concealed in their wood pile. Either they have failed to gather the real fiber from the plants or else they have picked ripe cotton and green, leaves and stems and near-by weeds in a wild and wasteful confusion. In no instance have

they been found to be satisfactory to either the cotton planter or the too credulous stock subscriber, and the darky has stepped into their wasteful tracks and gone on with his hereditary occupation. The new machine is called the Auto Cotton Picker, and its inventor, who also invented the round cotton bale, claims that when it is perfected, which has not as yet quite happened, it will divide the cost of cotton picking by five. A recent trial in Louisiana has attracted attention from cotton growers all over the South.

The machine is run by a gasoline engine and five negro boys operate it, each moving one of its five long arms. These become automatic only when they actually touch the boll. The boy must see to that, but in the trial the machine picked an average of 126 bolls a minute. This is at the rate of 3,000 pounds of seed cotton per day per machine. The machine straddles one row, which it picks clean, and also half of a row on each side. It is not strictly an automatic machine, but merely a labor-saving device, and as such there is much in its favor. It is greatly hoped that this machine will prove a success.—*The Technical World.*

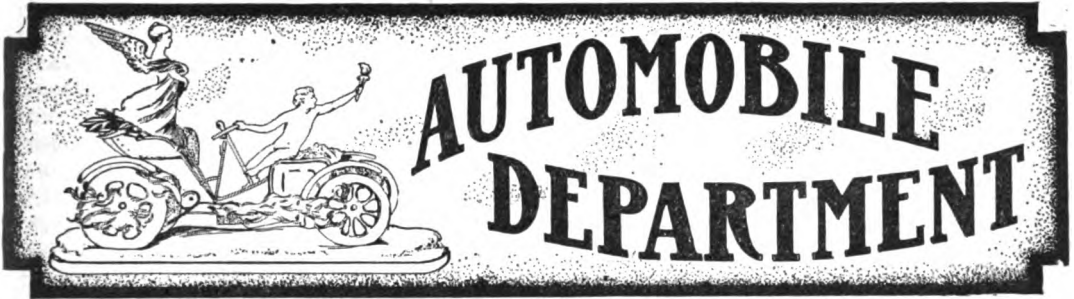

It is said that of 1,000 automobiles licensed in Iowa, the majority are owned by farmers or people located in the smaller towns.

A rather interesting feature of one of the English automobile publications is a page devoted to warnings to motorists of "police traps," and the readers are "warned to drive carefully" at such and such places on certain roads.

Judging from reports made by some of the drivers who are to be in this year's Gordon Bennett race, the course is a decidedly difficult one, and there has been talk of having the course changed for one safer for the contestants.

In a fuel consumption trial to be held in England late in May the following formula is to be used in determining the best result:

Weight of car and load.

 Gasoline.

In the article on carbureters in this issue there is an explanation of one difficulty which many people do not understand. The object of the carbureter is to bring together and mix a liquid, gasoline, with gas, air. But the physical laws governing the action of liquids are different from those governing gases. The carbureter, therefore, produces different results when the engine is running at different speeds, and it is to adjust itself to these conditions that the "automatic" carbureter has been designed.

A firm in Egypt has recently had shipped to it an agricultural motor equipped with a four-cylinder 24 H. P., which is fitted with a carbureter designed to use either gasoline, kerosene or alcohol. The engine is mounted directly upon a sling channel steel frame, as also is the gear box, which

contains the variable speed gear, giving motion to the machine through the agency of a counter shaft and side chains to the rear driving wheels. The engine is, of course, water cooled, the supply tank being placed in the forepart of the frame; the fuel tank is placed above it. In order to keep the ignition storage batteries charged, a small dynamo is installed and connected up to the engine when required. The machine, as well as performing the usual functions of plowing, harrowing, reaping, etc., may be used as a tractor. Its average speed is two and a half miles an hour, but this can be considerably increased when being used as a tractor.

An English contemporary in the automobile industry remarks that "the influence of the gasoline engine with regard to methods of ignition on gas engines can plainly be discerned. The gasoline engine when first manufactured commercially for anything larger than 3 H. P. had its charge fired by means of the hot tube, and electric ignition, when mooted, was scoffed at by gas engineers, and also by others who ought to have known better. Now we find that often where gas engines are on exhibition, magneto electric or ordinary electric ignition is employed on the smallest and highest powered engine. Truly, the survival of the fittest doctrine has worked in this respect of late years."

While this was the case in England, it was not so in America, where electric ignition in stationary engines had secured recognition as the better method of igniting the charge. For the sake of convenience, in case of difficulty with batteries, tube igniters were, and often are yet, placed on stationary engines. However, electric ignition had made its way sufficiently to show that eventually some form of electric ignition would be the one used almost universally.

C A R B U R E T E R S .

On April 13, Mr. Merwyn O'Gorman read a paper on this subject before the British Automobile and Cycle Engineers' Institute, and from this paper we have taken the following extracts:

They could not satisfactorily answer the question as to what they wanted in a carbureter without going back a step to see what they wanted from an engine. It seemed to him there were five chief essentials. (1) Sometimes they wanted the most power at the highest speed. (2) Sometimes they wanted the most torque at slow speeds, as when starting. (3) They occasionally wanted the most speed at various torques. (4) Sometimes they wanted the minimum speed at no available torque to enable the engine to run as slowly as possible when the car was standing. (5) Sometimes, as in the commercial motor, there must be the utmost fuel efficiency at all rates of working.

As regarded the quantity of mixture required to be taken out of a carbureter, a carbureter which was to meet all those engine requirements must be prepared to supply different quantities of mixture for these various results.

He was in a position to give one result under this head, a result for which he was indebted to Mr. G. H. Baillie, who had worked out the results for a small De Dion engine. It appeared from his experiments, with the air inlet and exhaust pipe drawing in at top speed, say 1,500 r.p.m., that the explosive mixture of air and gasoline taken into the cylinder was only 50 per cent of the volume swept by the piston. They were not accustomed to realize that opening the throttle to full speed caused such a diminution of the amount of gas that would go into the engine.

It was easily seen how this bore upon the question of carbureter design, and he took this opportunity to point out how important it was that they should have a knowledge of the volume of the air that it was possible to get into the engine from very slow to very fast.

The next point was as to quality—what was the best quality of mixture for the various conditions. The relationship between air and gasoline was not by any means constant, but varied according to the quantity taken, to the speed of the engine and to the

power required at any particular engine speed. It was possible to delicately adjust the mixture for the whole series of conditions, and then to collect samples of the exhaust gas and analyze each sample by condensation in the usual way with liquid air, and thereby to see what proportion of gasoline, burnt and unburnt, came out in the exhaust, calculating from that what proportion went in from the inlet. That would be fairly easy to do.

Why should they have automatic carbureters? The first reason was that the automatic extra air valve was introduced to give to the engine at high speeds a diminished quantity of gasoline per stroke. With or without the automatic valve, the engine refused to take it, owing to the inertia of the air and to friction in the pipe chiefly. So that the extra air could not be taken by the engine under ordinary circumstances. What they really meant was a diminished quantity of gasoline.

Besides this chief reason, there were others why less than the normal flow of gasoline was wanted at the highest engine speeds. Although the volume sucked in was one-third or one-half less, the compression was effected ten times faster. Therefore they had a much hotter and higher compression, and if the same amount of gas were compressed into the engine as when it was working more slowly, the pressure would be enormous.

The point was that when the speed of the engine increased the pressure was extraordinarily increased, and pre-ignition would take place. A poor mixture automatically given was necessary to save the situation at high speeds, unless they submitted to the inefficient process of diminishing the compression by strangling the volume of incoming gas.

The third reason was that the pressure was further increased and the temperature of the compressed gas raised by the difficulty which the exhaust gases experienced in making their escape. In practice, under such conditions, the exhaust was much less freely released, and it was under those conditions that abnormally high temperatures occurred.

The fourth reason was that at the limit of slowness, with normal mixtures, they failed to keep the engine rotating. If the

compression was very poor there was difficulty in getting the charge to ignite. This occurred when the engine was running extremely slow, also when the compression was poor, and in any case when the pressure was evanescent.

Therefore, for these reasons, it was important to have a tolerably rich mixture, but not overloaded at very slow speeds, the object, of course, being to get what was commonly called "flexibility" of the engine, so that from the considerations he had mentioned this engine question had become a carbureter question. An automatic carbureter ought to give right proportions of mixture to do a modicum of work at slow speeds.

Another matter in which the engine affected the carbureter was that of the relative sizes of each. Although the engine and carbureter were sold and made separately as independent purchasable commodities, the engine would not run at its best unless it was considered in conjunction with the carbureter, for the two were intimately related. The number of ways in which the mixture had been tampered with was very great. The first was the Jenatzy-Martini method of controlling the richness of the mixture by hand throttling the air on its way to the jet.

The second plan was to control the richness of the mixture by a spring valve flap which throttled the air on its way to the jet. When the air suction was rapid the flap was raised, and therefore ostensibly the vacuum would be diminished, and the amount of air drawn through it would be less.

From these devices one could easily see what the operation was in those carbureters that had been what he called "tampered" with. They could not measure the mixture; there was no means of measuring it, and the man who could produce a volume of air that was exactly required by the volume of gasoline would prove his carbureter to be automatic. No carbureter was so. It was a matter of whether one could tune up one's ear to obtain the best results.

He next showed the De Dion carbureter, giving simultaneous control and simultaneous throttle, one on each side of the jet. To see the advantage of that it would be interesting to note what happened. Supposing the throttle was opened, then sympathetically with it was opened another. The effect was to impoverish the mixture.

De Dion had also provided a by-pass so that the air not only increased the suction on the jet, but did so without any increased pressure. At the same time he could lower the throttle tube so that the air pulled on the gasoline as hard as it could. He was only indicating vaguely some of the ways in which the amount of gasoline had been tampered with instead of having just the normal amount which might have been sucked over by the engine.

Another method of tampering with the carbureter was to shunt some of the air by auxiliary valves, the openings of which were controlled by the pressure of the circulating water, as in the Napier; or to shunt some air away from the jet. The usual phraseology was to admit more air to the engine, but in reality it was to shunt some air away from the jet.

Another method, which was different from anything else he had seen, he should like to mention. It was throttled by varying the stroke of the inlet valve, and making the stem of the inlet valve control a needle in the jet. Suppose the method of throttling was to limit the stroke of the inlet valve, then, roughly speaking, when they were taking a lot of gas the inlet valve was traveling little. Therefore, if it was the inlet valve that opened the jet they got lots of gasoline when they were traveling with the inlet valve open and little when it was four cylinders, of the vertical type. The inlet valve through a cushion spring actuated a needle, which needle traveled into what might be called a jet or dripping place. The amount of drip which could come out depended on how far that needle traveled into the jet. The gasoline came through the opening. It was adjustable by a little cock. Unless the valve was back on its seat the gasoline might drip right through. A definite tap had to be shut off, so that no gasoline could drip through when the engine was not running. Throttling was done by limiting the travel of the inlet valve. The needle which closed the jet was pulled out at each stroke of the inlet valve movement. When the inlet valve was pulled out the little needle came out. The valve moved whole, and the needle also moved whole with it. The dose of gasoline, therefore, increased, so that in the case of hill-climbing, when the engine was running very slowly, and the throttle was very full open, they got a good large dose of gasoline. The time was longer for the gasoline to flow out, and the time of the opening of the valve was also

longer. So that in the very slow condition they got an open throttle and a rich mixture. The pressure was sustained because of the mixture being rich beyond normal. A slow speed and open throttle gave more fuel, while at high speed there was less flow of fuel. With the open throttle a fairly large quantity of fuel was wanted, but when it was closed the opposite was the case. The time allowed for the gasoline to flow varied, and although the movement of the needle was large, say at one-tenth of the normal, the time was small. On high speeds with closed throttle the movement was small and the time was small. Therefore, they got the least amount of gasoline per stroke. The distance of travel of the valve was very minute, and although the time the jet was open was not long, sufficient fuel was allowed to escape.

Another pretty device very similar to some of the others which were used to tamper with the mixture, was Brasier's. He caused two jets to face each other in such a manner as to make them collide, each preventing the other from increasing in output when the vacuum increased. This prevented the gasoline coming too fast. But suppose a little bit of grit got in, the arrangement was upset.

Continuing his description of the main points of certain carbureters, the lecturer explained that the Bollee plan was to employ two distinct carbureters carefully adjusted. Personally, he did not see why they should not have three. It meant the essential carbureter being repeated over again and adjusted to the conditions that might be present in order to win the Tourist Trophy. The throttle valve dropped one out and put the other into use.

Another plan was to introduce a resistance to the flow of gasoline to the jet, and another plan was to mechanically measure out the gasoline itself for each speed. This was not difficult, because in lubrication they measured out small quantities of liquid quite readily. Another plan was to increase the inertia of the gasoline by closing the jet with a loaded needle valve, as in the Oldsmobile. They had no float, but something which at high speeds caused the gasoline to have a lag or a laziness in coming out. It was allowed to flow, but it was lazy about it. When the engine was going fast the amount was lagged by weighting a little valve, and it could be further diminished by diminishing the diameter of the disc.

Having thus referred to some of the methods adopted in carburation, his last proposition was to consider what they ought to do for the future. The ideal carbureter was to be something very simple—something like the old surface carbureter, which could not be put out of order by a bit of grit. In attempting to set out the ideal let them suppose that cost was immaterial, and then come to the determination to provide against every eventuality regardless of complexity and expense. Among the conditions to be fulfilled were these: To keep out dirt and water gauze must be introduced in the course of the gasoline to the float case, and a large accessible pocket must be placed under the gauze and under the float to provide a collecting ground for grit, green deposit, and water. The pipe must be long and flexible; a tap must be provided above the bottom of the float chamber, so that the sediment in the chamber should not fall back into the valve seat.

Then, having got rid of these preliminaries, the float must be considered. The carbureter, if of the usual type, must have a constant level at the jet, whether it was going up hill or down; whether it was tilted by the camber of the road, or whether it was on the level. That required one of two things: Either an annular float was essential, or at least a float chamber, the central axis of which was very near the jet. They must have the widest range of carbureter that it was possible to have. If they could get the center of the float very close to the jet it would be a great advantage. It should be put very close, and yet not in the center of the jet.

In the ideal float, with which they were concerned, atmospheric pressure would count. The float should be of thin metal, and it should be dome or cup-shaped, or otherwise strong to resist the tendency to expand when the engine suction produced a slight vacuum in the float chamber, or when the barometer fell, either for atmospheric reasons or when climbing a mountain. The float top would bulge when the barometric pressure went up, and the suction of the engine kept on drawing gasoline and caused it to bulge. It was obvious they could cause the suction of the engine to be transmitted through the gasoline pipe to the float. That suction would cause the float to swell, and that swelling causing the float to rise, would have the effect of lowering the level of the gasoline in the jet. The amount of gaso-

line per stroke was altered according to the speed of the engine. Thus this fact could be utilized to bring into play the functions of the float, but it was an awkward law to bring into play, not only because it depended on the stiffness of the metal, but because the barometric changes would have a disturbing effect, and would cause air leakages into the float chamber. Therefore they learned their lesson from this, and made a little aperture in the chamber. They must put a tube in it, and make that tube long, so as to take the end of it away from the exhaust pipe.

Usable gasoline varied from .722 to .680 specific gravity, or nearly six per cent, so that within this range the float should be capable of easy and immediate adjustment by hand. An easy way to provide this was to permanently press the float slightly down into the liquid by a light spring. There was still a variation of density with temperature. Taking the lightest gasoline (.680), this on a winter day altered in density from .70 to .66 (a new 6 per cent variation) between the start and the time when the metal work under the bonnet became warm. Accordingly the float should be such as to close to the gasoline feed firmly with the warmest gasoline likely to be used. This necessity militated against the pointed float, because a six per cent variation of density meant that there would be a six per cent variation in the volume of the float submerged, which would result in the case of a pointed float in a serious variation of the height of gasoline in the chamber. It might amount to fifteen per cent of the total height of the float. A possible cure for this trouble would be to design a float whose volume increased with the temperature, but an easier cure was to employ a spring, the blade of which must be made of two dissimilar metals. The pressure of the spring relieved itself when greater buoyancy was required when the float case got warm.

It was clearly best not to draw the gasoline from the bottom of the float case, where fine dust and green deposit might be found accumulated in spite of all filters, but from as high up the side as possible. The root of this tube should be of large diameter, so that the velocity be very small, and therefore not likely to disturb the quiet settling of dirt at the bottom of the float. From the float chamber to the jet the gasoline had to flow at widely varying speeds, the range being about five to one for the usual ten to one

engine speed range, and at widely varying temperatures. Furthermore, the flow required was sometimes steady and sometimes unsteady, taking place in distinct short pulses. When the pulses were at the rate of forty per second on a four-cylinder car at highest speed, the flow was practically steady, so that friction in the tube and nozzle was important, but when the same car took four draughts per second the inertia of the liquid came prominently into play. This seemed likely to complicate the law under which the liquid flowed, so that they need not expect that the amount of liquid moved per stroke would bear any simple relationship to the amount of vacuum caused by that stroke. This law was even further complicated by the practical fact that either much or little liquid might be required both at fast and at the slow speed of rotation. Here was the backbone of the difficulty of carbureter design. The laws of gases under which the air moved through the pipes could be expressed in a simple formula. Unless the pipes were very simple and the current steady, the laws of liquids obviously could not be expressed by the same formula, because of the difference of physical state between liquids and gases, to which were super-added the complications due to fine capillary nozzles and the irregular variations in the viscosity of the liquid with variations of temperature. The head working upon the ordinary spray varied perhaps from two ounces to twenty ounces, and of the twenty ounces it would perhaps be fair as representing the ordinary case to consider that sixteen ounces were expended after the liquid had left the tip of the nozzle, and the balance remained for overcoming the resistances in the pipes. This would account for the jet of liquid being about three feet high if it were allowed to travel upwards unshattered.

It was found that if the temperature of the gasoline increased, its viscosity diminished, and, therefore, the loss of head of the liquid by friction in the pipe diminished also. To show how important this change in the character of the liquid was, he quoted an experiment of Mr. Sorel, who found that with gasoline having a normal density of .700, actually 40 per cent more liquid passed at 50 degrees C. than at what was by no means a very wintry temperature of 5 degrees C.

They might be able to arrange that the access of liquid to the spray should be some-

what more closed by a small temperature valve when the liquid was hot than when it was cold. On the other hand, when the air was hot a somewhat less quantity of gasoline would be required per stroke, and it was not at all absurd to suppose that the air would vary by as much as 50 degrees C. on any one day, or 70 degrees C. between an extreme winter and an extreme summer condition. So they would require that this little thermometer valve controlling the liquid should be opened by the difference in pull due to two thermometers, one of which was in the air duct and one in the gasoline duct.

Suppose a tapered needle was thrust down the jet to choke it by a flat spring in the air path, made of zinc and copper, so turned that as the copper expanded more than the zinc with rising temperatures the needle would be pushed lower down. The amount of aperture must be calibrated according to the air temperature law. The corresponding spring, which was immersed in the gasoline, opened a separate gasoline valve, and must be calibrated according to a curve of flow and temperatures like that given by Mr. Sorel. This curve of temperature, unfortunately, was not the same for all gasoline. Obviously so owing to their very varied compositions, for Mr. Sorel had also shown that denser gasoline did not vary so much with temperature.

It still remained to heat the gasoline in the float chamber and spray tube to a constant temperature, and thereby eliminate the necessity for this second adjustment. This might, perhaps, turn out to be considerably easier if they heated the gasoline by an exhaust bypass. All they had to do was to control the amount of hot water or hot exhaust gases by a thermostat. He would prefer using water rather than exhaust gases, because of the diminished chances of getting the thermostatic valve choked with soot.

It was Mr. Dugald Clerk who showed that the colder the mixture drawn in the better for the possible output of the engine, provided that as the gasoline was evaporated latent heat was supplied for the purpose. The amount of heat required was, therefore, proportional to the amount of gasoline used. As the mixture was not always of constant proportion, it would be best to heat the gasoline itself as it left the nozzle by making it impinge on a hot cone kept at a constant heat by a thermostat. This

method did not exist at present, but approximations to it existed by warming the mixture chamber into which the gasoline passed, and thus supplying the extra heat for which larger quantities of mixture were used by heating a portion of the air. The objection to this plan of passing a proportion of the air over a hot pipe was that when the gas was taken in slowly, say at half throttle, it got more heated than when the same volume was taken in fast, so that if the car was right for hill climbing it was probably wrong for racing at full power on a more moderate gradient. This resulted in the necessity for elaborately tuning a racing car to make the best average on a varying road, instead of tuning the carbureter in a skilled manner to give, not the best average, but the actual best possible result at each and every section.

He was afraid they would feel disposed to protest against his introducing three thermostats in a car to be supplied with air which in the ordinary course would be at various temperatures. His reply was that he was not so sure they would not yet even introduce a fourth thermostat into the air supply, but he was hopeful some such course would yet be adopted when they considered that little weight was added by these devices, and that one minute gained in a six hours' race meant quite a respectable victory.

Nothing but such rewards could pay for such expensive experiments, but when they had made the first perfect carbureter the cheapness of reduplicating it for commercial uses was astonishing.

The function of the spray nozzle was to minutely subdivide the issuing liquid, so that a very large surface was offered to the air for rapid evaporation. Each cylinder full of gas required a little cube of gasoline having about $\frac{1}{8}$ inch to the side, and this might be shot out of a single or out of many orifices, and as the evaporation took place, for the moment the liquid left the nozzle it was disposed to abstract all the heat it could get, not only from the air, but from the metal nozzle itself, thus lowering its temperature considerably. For this reason, if possible, the water heating should be brought as near as possible to the nozzle.

The control of the liquid after it left the nozzle had been elaborately dealt with, and various methods indicated in the examples of carbureters which he had given. He did not think he should be understating the

case if he claimed that the difficulties in properly dealing with the fluids after this point were at least as great as the sum of all the difficulties met with up to that point.

He should like to put forward the somewhat paradoxical suggestion that, much as they prided themselves in England on having stood together to fight the alleged master patent of Maybach's float feed carbureter, it might have been better for them if they had never won. For, supposing one-half the ingenuity that had since been expended on float feed spray devices had been turned into other channels, the riddle might have been solved in a simpler fashion. Excellent beginnings were made by surface and wick carbureters of the most amazing

simplicity of design. The physical difficulty of persuading a liquid and a gas to follow even remotely similar laws over a very wide range of variation of two variables, namely, the pressure and the duration of that pressure, was immense. If both the substances were presented in the gaseous form they would appear to be easier to deal with, as obeying by their nature identical laws as to the relations between volume, pressure and temperature, and similar laws as regarded their flow through pipes, and inertia.

There was, as it were, four keys in which the carbureter had to play the best music: 1. At full throttle—engine fast. 2. At full throttle—engine slow. 3. At closed throttle—engine fast. 4. At closed throttle—engine slow.

GASOLINE ENGINES FOR COMMERCIAL VEHICLES.

At the Institution of Mechanical Engineers, Westminster, a paper prepared by Mr. Edward Reeve was read on the above subject.

The purpose of the paper was to give a description of the leading features of some commercial vehicles, and to point out the main advantages of particular systems, and the following is the substance of it:

The question of power is one that demands considerable attention. Owing to the necessity of having a boiler and carrying fuel and water, the steam engine does not appear suitable for this class of work, and it is not within the scope of this paper to discuss it.

With oil engines it will be shown by the results of experiments that the maximum efficiency is reached when running with full load at normal speed, therefore it is essential for the economical running of vehicles that the load transported should be as regular as possible, and the power of the engine should never be too much in excess of the work it has to do.

The accompanying tests were made with

a single-cylinder Wolseley horizontal engine, 4½ inch bore by 5 inch stroke.

Test 1—Full throttle, full load, normal speed.

Test 2—Half throttle, half load, normal speed.

Test 3—Half throttle, half load, full speed.

Whether heavy or light oil will be predominant in the future is still doubtful. The difference per H. P. per gallon consumption is hardly appreciable; but, whereas the light oil will vaporize in the atmosphere, it is necessary to heat the heavier oil, and for that purpose a by-pass is taken from the exhaust gases or from the water circulation in the vicinity of the combustion chamber, and by this means the heavier oil can be employed after the engine has been started.

The hot tube ignition has now been almost entirely superseded by electrical, and of the many forms of electrical ignition the batteries and coils are very often employed, but the disadvantage of having to recharge periodically debars them from universal use.

	1	2	3
Duration of test in minutes.....	30	30	10
Average number of r.p.m.....	900	900	450
Average B. H. P.....	6.4	3.8	1.9
Gasoline consumption per hour, gallons.....	0.58	0.4978	0.494
Gasoline consumption per B. H. P. per hour, gallons.	0.0906	0.131	0.26
Gasoline consumption per working stroke, cubic inches	0.00679	0.00516	0.01225

What is required is a self-contained ignition, or such an apparatus that the power of the engine itself is utilized to generate the spark. This has been obtained by the magnetic types, such as the Simms-Bosch, Eise-mann, etc., but notwithstanding the many improvements that have taken place lately, they have not proved more reliable than the batteries and coil.

With regard to vaporization, the use of auxiliary air valves is undoubtedly a move in the right direction. With a single-cylinder Wolseley horizontal engine of $4\frac{1}{2}$ inch diameter by a 5 inch stroke, running at normal speed, without an auxiliary air valve, 6.15 H. P. was obtained, but with the same engine, with the use of atmospherically operated auxiliary air valve, 6.7 H. P. was reached. So many figures have been given to show the advantages of mechanically operated induction valves that it is hardly necessary to introduce them here, but as the power of the engine depends upon the volume of the charge admitted at each stroke, it will be readily understood that with atmospherically operated induction valves the opening and closing is much slower than with the mechanically operated ones, therefore the time the valve is full open is less, and consequently the total volume of the charge admitted is decreased. The difference is quite pronounced in the large cylinder engines, but with the small engines, say up to $4\frac{1}{2}$ inch diameter cylinders, it is very questionable whether the extra moving parts do not counterbalance any advantage that may be possessed by them.

As the vibration in the vehicle should be as small as possible, especially in omnibuses for public service, it is important that the moving parts of the engine should be balanced.

By carrying the water above the engine circulation takes place by convection, but this method has not proved itself reliable, so a pump is used, and this gives a positive circulation. In some engines it is so arranged that if the pump fails, natural circulation will take place.

The position of the engine, whether vertical or horizontal, is a matter of convenience only; the efficiency is the same, but with a horizontal type it is possible to keep the center of gravity of the vehicle lower, and to place the footboard over the engine; this allows of going away with the large bonnet in front, and enables the seat to be brought forward,

Of first importance is some means of disconnecting, at will, the motion of the engine from the road wheels by means of a clutch; the best position for this mechanism is between the engine and gear box. The duties required of a clutch are such that it must be capable of transmitting any desired fraction of the power of the engine, and changing these proportions without shock; in other words, the clutch must be capable of slipping and allowing the engine to run faster than necessary for the speed of the car at the moment.

The drive, to a considerable extent, depends upon the position of the engine, but as there is no difference in economy, the position of the engine should be made to suit the drive, which should be as efficient and flexible as possible. The Wolseley drive was shown, this being called the parallel drive. From the engine the drive is through a single Renold's silent chain to the gear box, and from the gear box it is transmitted to the rear road wheels through two side roller chains. With this type it is not necessary to have bevel gearing, and it gives a sufficiently flexible drive. In another method, a central shaft drives the gear box from the engine, and from the gear box bevel wheels and a pair of roller chains are employed to transmit power to the back axle. This is commonly used with vehicles having vertical engines. It necessitates the use of bevel gears, and it is not so flexible as the former type. Another showed a central drive straight through to the rear axle. With this it is necessary to have bevel gearing and a live axle, and it was stated to be not so flexible as either of the former types.

The typical speed change of modern practice consists of sliding gears. Upon the squared portion of the first countershaft a number of gears are arranged to slide through by forks, operated by a drum with grooves in it and controlled by the driver in such a manner as to bring them alternately into mesh with gears on the second motion shaft. This second shaft gears with the differential shaft, which has the sprocket wheels for the roller chains fixed on each end. By sliding these gears into the different positions in this design, two or more speeds are obtained.

One brake shown was of a double-acting band brake, lined with wooden blocks. This was described as a good type of brake for vehicles where hills are not long, but if they are kept on long they generate a considerable amount of heat, and the blocks are lia-

ble to burn. By lining the band with metal shoes this is prevented, but they are apt to drag on the wheel, and then are noisy.

Another figure showed an external shoe brake, which is very effective. This consists of two brake shoes, which are applied to opposite sides of the brake drum. A compensating link motion applies the shoes equally on the drum. This brake has been used on all types of vehicles, and has given little trouble.

Also was shown an internal shoe brake, arranged to operate (in this particular case) on the chain wheel on the rear axle.

It is essential that semi-elliptical springs should support as large a proportion of the weight of the vehicle as possible when rubber tires are used, to prevent excessive wear, and hence the disadvantage of live axles. It is important for passenger traffic

that the springs should be sufficiently elastic. The weak point of this method of suspension is that the unevenness of the road gives the vehicle a side movement which the springs are unable to take up; the reaction of this comes on the tires, and they wear out more quickly. By the introduction of an oscillating axle the unevenness of the roads is allowed for, without throwing any undue stresses on the tires or frame.

The general method of steering, the Ackerman, was invented in 1818, and described by himself as being a means whereby a vehicle "will turn within a small compass with safety, because the wheels do not materially alter their bearing upon the ground when they are placed in the greatest degree of obliquity." This was illustrated by means of a view of the steering mechanism of a car.

MOTORS FOR AGRICULTURAL PURPOSES.

The following from *The Autocar* gives the situation in Great Britain. In America the conditions are not exactly the same, as several traction gasoline engines have been built not exactly in accordance with the specifications called for by this article.

Although the internal combustion engine in its stationary form is very largely employed where reliability is the main consideration, and has also been used considerably for motor cars where weight is of great importance, it is rather curious that so little has been done to take advantage of it for the heavier class of self-moving engines. True, we find it employed with considerable frequency for heavy trucks, and those who have had much experience with these machines fully expect it to entirely displace steam before very long. Explosion engines so used are, however, at present very few in number, while agricultural engines of the traction engine type are very numerous, and are increasing rapidly. It would seem that the same advantages which have brought the motor so much to the front for other purposes, viz, the simplicity of the machinery and absence of a boiler, and the very small amount of fuel and water required, would obtain as largely on a traction as any other engine, and would be found of a very great advantage indeed on a plowing engine. One of the great reasons why steam plowing is not really successful in this country is the very great expense of leading

water to the engines. Leading coal is also a considerable item, if far from a station, but the water is usually the greater. There are many fields where there is no supply available, and where it has to be led a considerable distance. Further, almost all water supplies in the country are at the bottom of the valleys, and therefore the water has to be led up hill. If this is done (as usual) by horses, then it sometimes takes as many horses as would go a good way towards plowing the land without the engines. I have recollections of driving a plowing engine on some fields where it took eight horses, three men and three water carts to keep us going with water, and even with all these we frequently had to stop or run easy because we were short. Besides this, there was a load of coal to be fetched every day. Now, suppose the engines had been oil engines, it would have been quite possible to have so constructed them that they would run for a week without water, and for three or four days without oil. This would result in an enormous saving, and it is quite possible that it would make motor plowing a success. For threshing the saving would not be so great, as there is usually, but not always, water handy; but for traction work there would often be a great advantage in being able to go long distances without taking in supplies. Incidentally, there are advantages in the fact that an oil engine does not throw out sparks, and can be started up

much quicker than the steam engine can get up steam.

To make such an engine a success would necessitate its construction by an agricultural engine maker, aided by motor experience. The road wheels, winding gear and transmission would probably be exactly like those on steam engines, but in place of the steam engine there would have to be an oil engine and a friction clutch. The engine would, of course, have to use heavy oil, not gasoline, and would be a compromise between the stationary oil engine and the motor car type. That is to say, it would have to be very much more substantial than the latter, but by taking advantage of motor car experience it might be made very much lighter than the former, and capable of being run over a much greater range of speeds. How the details would work out it would be difficult to say, without actually making

sketches of the machine, and no doubt considerable experience would be needed to make a thoroughly satisfactory machine. As a suggestion, we might take the following: Two-cylindere horizontal engine with cylinders about 8 inches by 10 inches. This should be capable of working up to 30 H. P. or 35 H. P. at 350 to 400 r.p.m., and somewhat more at higher revolutions temporarily, if desired. A large fly wheel must be permanently fixed to the shaft, and also a friction clutch driving a length of shaft in line with a driving pulley for a belt upon it. On this length of shaft there would be the necessary gears for, say three different changes of speed and reverse arranged much as in motor car practice, driving a countershaft, and from this countershaft the driving wheels and winding drum could be driven in the usual way, with the usual clutches to connect and disconnect.

TRADE PUBLICATIONS.

James Runyen & Sons, Redkey, Ind., are sending out a mailing card showing their positive feed oiler for gas engines of all kinds.

I. H. C. gasoline engines are well covered in a new catalogue just received from the International Harvester Company, of Chicago. The catalogue is printed in two colors.

The Mianus Motor Works, Mianus, Conn., send out a very neat and well printed catalogue of their model 1905 marine engine, which is a two-cycle, vertical motor in units from 2 to 12 H. P.

"Sta-Rite" spark plugs are listed in many sizes in a circular issued by the R. E. Hardy Company, 225 West Broadway, New York City. Still another lists some accessories in the way of sparkers, etc.

The Cincinnati office of the International Harvester Company of America are sending out mailing cards showing their 2, 3 and 5 H. P. vertical engines and 6, 8, 10, 12 and 15 H. P. horizontal engines.

The Duryea Power Company, Reading, Pa., have issued quite a good many leaflets, each covering a separate heading and devoted to a separate subject. In order to make it convenient for prospective customers to secure information along just the

line they desire, the Duryea Company has issued a "Duryea Library" leaflet, being an index of the previous publications.

"Everything for you and your auto" is the motto of the Motor Supply Company, 1427 Michigan avenue, Chicago. A new catalogue from this company contains a very complete list along this line.

"Points To Be Considered in Selecting an Igniter," is a sixteen-page booklet from the Goodson Electric Ignition Company, Providence, R. I., and relates to the advantages of the Goodson system of ignition.

"Built To Run and Do It," is the motto expressed on the new catalogue of the Regal Gasoline Engine Company, Coldwater, Mich. Several types of automobile, marine and stationary engines are shown, as well as propeller wheels.

The Advance Manufacturing Company, Hamilton, Ohio, make a specialty of direct belted gas engine electric light plants, and a mailing card received from them shows a special gas engine dynamo made in units from 16 to 200 light capacity.

The catalogue of the Stratford (Ontario) Mill Building Company contains more information relative to their gas and gasoline engines, and how to operate them, than is contained in the instruction books of many

engine makers. This feature of a catalogue appeals to the prospective buyer, for he learns that the engine is not a complicated machine, and that it may easily be understood and cared for.

Catalogue No. 8, pocket size, has been issued by the William Powell Company, Cincinnati, Ohio, and shows many types of lubricators, oilers, indicator cocks, priming cups, etc., which are especially designed for use on gas and gasoline engines.

"Are you open to conviction? The figures are startling." Such a question and answer on a blotter showing a Fairbanks-Morse suction gas producer and gas engine is being distributed by Fairbanks, Morse & Co. A postal to any of their branches will explain the figures.

"A Chapter on Pulleys" and "A Chapter on Lettering," are two pamphlets just issued by *The Draftsman*, of Cleveland, Ohio. The price is twenty-five cents each. The former comprises matter, collected from various sources, relating to speeds, belts, rims, arms, hubs, keys, etc. It should prove valuable to anyone who has any designing or selection of pulleys. The second booklet, as its

title indicates, relates to lettering drawings, and the instructions given, together with the specimens shown, will interest any draftsman.

The Motsinger Device Manufacturing Company, 109 Main street, Pendleton, Ind., manufacturers of the "Auto Sparker," are sending out a complete catalogue of their device, accompanied by a colored lithograph showing actual size, etc., and also accompanied by a letter explaining the merits of the machine.

A mailing card from the Hart-Parr Company, Charles City, Ia., gives a detailed sectional view of their oil-cooled engine and accessories. This card should prove of interest to possible purchasers and of especial interest from an educational standpoint to users of Hart-Parr engines.

The Shepard Lathe Company, 121 West Second street, Cincinnati, has recently issued a new catalogue showing their foot and power lathes, planers, shapers, etc. A statement of some gap screw cutting lathes furnished the United States Government goes to add to the makers' claims of high quality for their tools.

I T E M S .

Every admirer of jewelry knows the name of Tiffany. Not so many know that Tiffany & Co's plant at Forest Hill, Newark, N. J., contains a 15 H. P. gas engine.

On May 6 the mechanical branch of the Association of Licensed Automobile Manufacturers listened to papers on "Ignition," by Mr. John Wilkinson and Mr. Hiram Percy Maxim. On June 2 "Carbureters" will be discussed.

The Alden Sampson Manufacturing Company, Pittsfield, Mass., manufacturers of automobiles, will erect a plant. The buildings will include a main building, 75x125 feet, of steel and concrete, a building for office and drafting room, one for the storage of automobiles and testing motors, and a power building.

E. D. Loane, Jr., & Co., and W. K. Thomas & Co., both of Baltimore, Md., have consolidated their businesses and incorporated, and will be hereafter known as the W. K. Thomas Company. They will carry on a general contracting and engineering

business, but will continue to make gas engines, the department receiving greatest attention. They state that they will also manufacture diaphragm circulating pumps and other specialties, and that they seek a line of three-port two-cycle engines that are accessible and reasonable in price, and that they will contract for a quantity of such machines and invite correspondence.

On Friday, May 12, Mr. E. W. Roberts, of Clyde, O., delivered the opening lecture of a series on automobile construction and operation, inaugurated by the educational department of the Central Y. M. C. A., of Louisville, Ky. The lecture opened with a series of what were to at least a portion of the audience startling experiments, showing the fallacy of many notions about this fuel. After the experiments Mr. Roberts gave a talk on the general construction of an up-to-date gasoline automobile, illustrating the talk with 50 lantern slides prepared especially for the purpose. The attendance was very good and there has been a large enrollment for the series of lectures, for

which have been engaged some of the most prominent manufacturers in the country. On May 25 Mr. Elwood Haynes, of the Haynes-Apperson Company, Kokomo, Ind., lectured in the course. Mr. Douglass C. Paige, the educational director of the Louisville Y. M. C. A., has charge of the course.

Western Gas Engine Company, Los Angeles, Cal., are the successors of the Western Iron Works (Incorporated). The old officers continue, and Mr. W. H. Frost, former manager of the sales department, is Secretary of the new company.

Arrangements have been completed between the Lazier Engine Company, of Buffalo, N. Y., and the DuBois Iron Works, of DuBois, Pa., for the manufacture of the Lazier gas and gasoline engines. Arthur A. Lazier, former Vice President of the Lazier Gas Engine Company, patentee of the engine, has secured the control of the combination, which will be known hereafter as the Lazier Engine Company, with head offices in the Ellicott Square, Buffalo, N. Y. The Lazier engines have been built in 18 sizes, from 2 to 100 H. P.

In describing his steam plant, a recent writer in one of the trade publications said: "Our steam plant consists of a boiler with a large number of joints under high pressure; a long line of suspended piping under like pressure, and subject to severe expansion strains; a group of pumps, traps, condensers, valves, in conjunction with a complicated exhaust, with which it takes a man a long time to get acquainted sufficiently to do the right thing at the right time." Compare that plant with a gas engine plant. The gas is led directly to the engine from the city gas mains, water is also easily procured, batteries furnish the spark and the power is ready on the instant; it is also so simple that complications are almost unknown and trouble reduced to a minimum. —*Gas News*.

The Automatic Machine Company, of Bridgeport, Conn., have recently brought out several new sizes of their marine engines. The new sizes in general follow out the same lines as the original "Automatic." It has been found advisable to make two changes, which have proven more satisfactory. First, the igniter has been very much improved by reducing the number and weight of its moving parts, thereby making it more durable and reliable, and more economical in the consumption of bat-

teries. Second, using a special carbureter, which gives a positive fuel feed at any position of the throttle, giving a mixture that is absolutely perfect at every position of the throttle, and only one valve to handle, which is a very important feature in marine engines, where it is necessary to run at a low speed, as for dredging purposes, and still have the engine respond to the throttle instantly, without danger of stopping or flooding.

The Automatic Machine Company have recently installed the following engines: 40 H. P., for H. E. Downs, Greenport, N. Y.; 28 H. P., for Forrester & Hoag, Prince Bay, N. Y.; 21 H. P., for W. Van Popering, Sayville, N. Y.; 14 H. P., for James Golden, South Norwalk, Conn.; 11 H. P., for Oliver Le Cluse, Bayport, N. Y.

In consequence of the remarkable increase of their business, the H. W. Johns-Manville Company have found it necessary to establish more branches in order to facilitate the handling of their business. The new branches are in the far west—San Francisco, Seattle, Kansas City, Los Angeles, Little Rock and Minneapolis. With these in addition to the old branches, New York, Milwaukee, Chicago, St. Louis, Boston, Philadelphia, Pittsburg, Cleveland, New Orleans, London, Paris and Brussels, the company now has eighteen branches, covering the entire United States and Europe.

The following questions relating to gas engines have been proposed for discussion at the International Congress, which will be held in connection with the exposition at Liege, Belgium, during the coming summer:

The present state of the generic theory of internal combustion motors and its application to the determination of the dimensions of these motors.

Codes for the tests of internal combustion motors; the observations which should be made; calibration, allowances, methods of use and results to be obtained.

The present condition of the question of regulation of internal combustion engines, two or four-cycle, and single and double acting.

Gas engines of large powers for producer and blast-furnace gas; the manufacture of producer gas; producers for bituminous coal.

Gas turbines.

THE GAS ENGINE.

STATIONARY—AUTOMOBILE—MARINE.

PUBLISHED MONTHLY BY

The Gas Engine Publishing Co.

Blymyer Building, Cincinnati, Ohio.

ADVERTISING RATES ON APPLICATION. Address All Communications to the Company.

Entered at the Postoffice at Cincinnati, Ohio, as Second Class Matter Feb. 20, 1899.

VOL. VII.

JULY, 1905.

No. 7.

Domestic Subscriptions, \$1.00 per Annum.

Single Copies, 10 cents.

Foreign, \$1.50 per Annum.

We have recently received a catalogue of marine gasoline engines which contains a certain class of information relative to these engines which many engine makers would consider information not to be divulged under any circumstances. The matter referred to is a page of detail dimensions of the various sizes of engines built by the company. We do not mean that merely the bore, stroke, over all dimensions, floor space, etc., are given. The page is more complete than many detailed shop sheets we have seen used in some factories, but it is not accompanied by drawings. The diameter of the valves, lift, area of inlet and exhaust valves, compression pressure, and much other information of this kind is given. This page illustrates a change that has been taking place among American manufacturers in all lines during the last few years. A manufacturer used never to be willing to disclose to the general public or his competitors details of sizes and processes of construction. Gradually this has been changing, for various reasons. In the first place, it is practically impossible to keep a competitor from finding out these things if he wants to. One manufacturer we know has a list of gas engines built by many different firms and giving the bore, stroke, rated speed and H. P. of all of them. In the second place, what is the use of trying to conceal this information? The other fellow will gradually learn most of it, and what harm does it do for him to know the size of the piston pins, for instance, in your 10 H. P. engines? If you know it is plenty strong, what harm can be accomplished? Of course, there are certain secrets, such as processes of doing work rapidly, which manufacturers can not be expected to disclose readily. But the purchasers of gas and gasoline engines of today are getting to be more inquisitive as to the di-

mensions of engines, what the parts are made of, how they operate, and how they are made, and it is in obedience to these inquiries that the manufacturers of today must be willing to give more or less of this detailed information to the public.

As most of the gas engine manufacturers are aware, there was organized several years ago an association of gas engine manufacturers. It died after a short existence, for reasons well known to the members. Since then we have been asked by quite a number of engine makers to take steps to organize such an association. One company quite recently undertook some initial steps along this line, but owing to the unfavorable attitude of one of the larger companies dropped the matter. The companies who are not in favor of such a movement ask us, whenever the matter of an organization is taken up, what good it would do. A case in point is the matter of freight rates on portable gasoline outfits, as referred to in another column. The individual shippers of engines, none of them having any very extraordinary influence, are able to accomplish very little with the official classification committee. An association of gas engine makers, combining the influence of many large companies and many more smaller companies, would be able to present a front which the committee could not ignore, as they can and do individual statements of the case. This is merely one thing such an organization could do for its members. There are very many associations of men in the same line of business which are every day accomplishing more for their individual members than could be expressed in money values, but certainly worth many times the expense of these associations. Their success and what they have done are known very extensively, so that there

should be no question as to what a similar association, conducted on proper lines, would be able to do. In view of the numerous requests made of us by various manufacturers at different times, we would be pleased to hear from all who feel sufficiently interested to express their views on the desirability of such an association

We recently noticed a statement in a new book on automobiles that gasoline

was first used commercially in an internal combustion engine in 1888 by Van Duzen, of Cincinnati. On investigating the matter we find that the Gasmotoren-Fabrik-Deutz, of Cologne, Germany, used gasoline in commercial engines as early as 1880, and very soon after that the Otto Company, of Philadelphia, used the same fuel in this country. If anyone has records of still earlier use of gasoline fuel in commercial use, we should be glad to hear from him.

THE REASONING GAS ENGINE OPERATOR.

BY ALBERT STRITMATTER.

"I have a gasoline engine which, while running at full speed, sometimes fails to fire the charge correctly and loses speed, nearly stopping altogether. Everything appears to be all right, as far as I can see. Can you tell me the remedy?"

Such is a list of questions which a gas engine operator recently asked. As he was not a gas engine expert, it could not be expected that he would at once drop onto the cause of the trouble and remedy it. Evidently he had endeavored to find the difficulty, but without success. And while he did not give all the symptoms which were probably present, and which would lead a more experienced operator to locate the trouble, yet, from such information as he does give, we are able to trace the cause to some one of several possible sources, and in doing so it may throw light on how the reasoning gas engine operator locates difficulties with these engines.

Many times a gas engine expert, on going to a shop, where trouble with an engine has been reported, will step to some part of the engine, will tighten a nut here or loosen one there, or pull a piece of waste out of some crevice, or will adjust some valve or igniter rod, and at once the trouble ceases. To the inexperienced operator, who has perhaps spent many hours in a vain endeavor to locate the cause of his trouble, this proceeding appears to be nothing short of marvelous. But to the expert it is the simplest thing in the world. Perhaps while he has been approaching the building he has been listening to the noise of the engine and has made up his mind at once that the trouble is in a certain place. When he reaches the engine he finds at a glance

that his preconceived idea is correct, and the remedy is a matter of only an instant adjustment. Very simple it appears to him, and simple it really is, but we can not expect to be experts in an instant, nor need any gas engine operator feel that by carefully studying and caring for his engine he will not be able to acquire this reasoning process which will do so much to locate, and avoid, for that matter, difficulties.

To return to the questions given before, how would the reasoning operator endeavor to locate the cause of this trouble? There are several things which give us a possible clue. In the first place, the engine evidently starts without much trouble, for if it did not the owner would probably have mentioned that fact. Judging by the inquiries, his trouble does not begin until the engine gets up to speed and runs a while, when all of a sudden it begins to slow down, almost stopping, and then it may start up again. Now, what could occur which would produce such an effect?

"In case of trouble," said a gas engine salesman to the writer recently, "I always look at the ignition system first. In nine cases out of ten the trouble will be with something connected with the ignition."

Where troubles arise of an intermittent nature; that is, where the trouble is evident only at regular or irregular intervals, not being evident in the meantime, there is almost certainly a cause in the ignition system somewhere, for troubles that occur in other parts are more like to be continuous in nature. In the present instance we must try and find what, if anything, would interfere with the operation of the igniter when the engine gets up to speed, but which

would not permanently interfere with ignition, acting only spasmodically.

It is well known among gas engine experts that a battery which is just beginning to weaken sufficiently to need renewing will act in this way. This applies particularly to dry batteries. When a battery has been used for some time, or has been short circuited, it may still give a spark which will ignite the charges most of the time. But if the engine is on full load and takes a charge every time (if a hit-and-miss engine), it requires a maximum number of sparks per minute, and this is a drain on a weakened battery, so that every once in a while the engine will miss ignition. When it has missed two or three, the battery may have gained enough strength to give a spark which will ignite the next few charges. In the meantime the engine has slowed down in speed, and may stop if too long a time intervenes before the next impulse is received.

If such is the case, the unignited charges will be exhausted, and later on will be ignited by the flame from the next charge which is ignited. This results in exhaust pipe explosions, which are not at all dangerous, so far as that is concerned, but which are alarming to persons in the vicinity. The inquirer who sent in these questions relative to his engine said nothing as to exhaust pipe explosions, but it is quite likely that they occur.

But a weak battery is not the only thing which would perhaps cause this intermit-

tent ignition. A loose connection in the battery wires or a break in the wires might cause it, as at times the connection would be good and at other times not. Perhaps dirt or grease accumulates around the igniter points or spark plug at times, causing imperfect ignition. The writer has also known of cases where the insulation around the ignition points was cracked. When the engine was cool no trouble resulted, but as it got warmed up after running a while the crack would open up and the igniter would not always give a spark. Renewing of the insulation is, of course, the only remedy in such a case.

If the points get dirty or greasy quickly, then there is probably something wrong with either the fuel feeding device or the lubrication of the piston. Too much lubricating oil will result in burning of the surplus with a clogging of the piston rings, valve stems, igniter, etc. This difficulty, however, would not likely be intermittent, but would continue right along until the parts were cleaned. The same thing would be the case if the trouble were caused by feeding too much fuel, which, likewise, results in a deposit of carbon, with clogging of the parts.

A weak mixture might possibly cause the trouble, as it might be just weak enough, i. e., poor enough in gas or gasoline, to cause failure of ignition, but such trouble would likely occur at any time in the operation of the engine, and not merely at full speed.

INSTALLATION NOTES FROM EVERYWHERE.

A Diesel engine in an English street railway power station used shale oil at a cost of \$22 a ton, and the kw. hour cost for fuel was a little over eight-tenths of a cent.

At Seraing, Belgium, two blast furnace gas engines of 200 H. P. each operate generators for running cement mills. A 1,500 H. P. double acting, four-cycle engine, has just been installed. Its speed is 100 r.p.m., the bore is 39.37 and the stroke 47.63 inches. Two single-acting tandem engines of 700 H. P. each have bores of 35.43 and strokes of 39.37 inches, and operate at 139 r.p.m.

A Swiss electrical construction company has for eight years experimented with the

coupling in parallel of a gas engine driven generator to an alternator driven by a turbine. By means of three-phase current supplied by a group of generators with a gas engine, the transmission of 200 H. P. was accomplished.

Blast furnace gas engines, direct connected to electric generators, are employed in a foundry at Esch, Luxemburg, the pair of horizontal single-acting 35.4 x 41.3-inch cylinders on opposite sides of a 19.7-foot fly-wheel. Their speed is 120 r.p.m., and they are guaranteed each to develop a continuous output of 660 H. P. with blast furnace gas of 96 B. T. U. calorific value per cubic foot, and a dust content of 0.001 ounce per cubic foot.

SOME GAS POWER TESTS.

In a paper read before the Manchester (England) Association of Engineers, on "Power Gas Plants," the following particulars of tests were given:

Test of gas engine, rope-driven dynamo and suction plant at the Milford-on-Sea Electricity Works.

The engine was one of Crossley's, with 11½-inch cylinder and 24-inch stroke, the fly-wheel being grooved for 4-inch ropes, which drove a Siemens shunt-wound dynamo of 25 kw. capacity at 700 r.p.m. The suction plant was the first of the size made by Messrs. Crossley, and the installation had been at work some months at the time of the test. This was commenced with a flying start, the producer being at the same time filled with coal to a predetermined level. The coal used for anthracite, about 1-inch cube, and a sample was tested at the National Physical Laboratory, the calorific power being certified at 14,805 B. T. U. per pound.

Duration of test	hours	3.49
Average load of dynamo	kw.	23.62
Average r.p.m. of engine		232
Average number of explosions		113
Average mean pressure of indicator diagrams	lbs.	65
Average I. H. P. of gas engine		46.25
Total coal used during trial	lbs.	133.50
Average per hour	lbs.	34.95
Coal per kw. hour	lbs.	1.48
Coal per I. H. P. hour	lb.	0.755
Assuming mechanical efficiency of engine to be 85 per cent. as is usual, the B. H. P. of engine was		39.31
Coal per B.H.P. hour	lb.	0.89
Efficiency of dynamo and rope drive,	per cent.	80.4
Thermal efficiency of fuel conversion,	per cent.	22.8

Test of special engine, coupled direct to dynamo, with suction gas plant working with ordinary gas coke.

The set tested was one of three for the Howrah station of the Calcutta Electric Supply Corporation, Limited. The coke was obtained from the Manchester Corporation Gas Works, and the sample analyzed was certified by the chief chemist to have the following percentage composition: Ash, 15.6; moisture, 1.3; Volatile matter, 1.8; fixed carbon, 81.3. Its calorific value was 12,411 B. T. U. per pound. To insure complete accuracy with regard to the measuring of the fuel after the test run, the ashes and clinker were removed from the lower portion of the producer, and the fire was made good again to a predetermined

level, at which the start was commenced. The actual time of the full-load test was six hours, but the producer was working 20 minutes before this, to get the fire in good condition for starting, and the fuel so burnt was not deducted from the total consumption, so that the results given below would have been slightly better if any arrangement had been made to measure the amount of such coke burnt before the commencement of the full-load test. One feature of the trial was the uniformity of the indicator diagrams, and the regularity of the quality of the gas, which showed on analysis the following percentage composition: CO₂, 7.8; O, 0.5; CO, 21; CH₄, 0.2; H, 15; N (by remainder), 55.5. The engine had an 18-inch cylinder, with 24-inch stroke.

Duration of trial	hours	6
Average load of dynamo	kw.	61.4
Average B. H. P. of engine		89.71
Average I. H. P.		104.83
Maximum mean pressure of indicator diagrams	lbs.	85.40
Minimum mean pressure of indicator diagrams	lbs.	80.3
Average mean pressure of indicator diagrams	lbs.	81.35
Average number of explosions		83.55
Average number of r.p.m.		200.20
Total fuel consumed	lbs.	488
Fuel per hour	lbs.	81.330
Fuel per kilowatt hour	lbs.	1.325
Fuel per I. H. P. hour	lb.	0.779
Fuel per B. H. P. hour	lb.	0.910
Mechanical efficiency of engine ..	per cent.	85.57
Thermal efficiencies—		
Electric energy at terminals ÷ B.T.U. in fuel	per cent.	20.80
B. H. P. energy ÷ B.T.U. in fuel ..	per cent.	22.71
Energy indicated on engine ÷ B.T.U. in fuel	per cent.	26.54
Heat efficiency of producer plant, calculated from the known efficiency of the gas engine	per cent.	89.50

Test of bituminous type gas plant and two gas engines.

The plant was designed to give 124 B. H. P. working load, and was of 150 B. H. P. maximum capacity. A guarantee had been given that the consumption of common Derbyshire slack coal should not exceed 1½ pound per I. H. P. hour, either working at 150 or with any intermediate load down to 50 I. H. P., this consumption to include all fuel used for auxiliary steam raising in the boiler. The calorific value of the fuel was 12,110 B. T. U. per pound. Each engine had a 16-inch cylinder, with 21-inch stroke. The first test was taken with the two engines at work, and was continued for six hours, but as the guaranteed coal consumption seemed to be easily obtained.

it was decided to proceed with the more crucial test, viz., with one engine only at work, approximating one-third load. This test was of 24 hours' duration. At the end of the runs the producer was poked, and the table rotated to insure a clear fire before the fuel necessary to fill the producer to the level was weighed in at the end of the test.

	1st Test.	2nd Test.
Duration of test hours,	8	24
Fuel consumed in producer lbs.	440	1012
Fuel consumed in steam boiler lbs.		130
Total weight of fuel lbs.	528	1142
Average per hour lbs.	88	47.58
Maximum pressure on diagram lbs.	101	103.00
Minimum pressure on diagram lbs.	97	95.00
Average pressure on diagram per cent.	98	97.30
Average explosions per minute—		
No. 1 engine	41.47	46.65
No. 2 engine	52.18
Average I. H. P.—		
No. 1 engine	43.34	48.4
No. 2 engine	54.53
Total average I. H. P.	97.87
Deducting power required for driving gas plant machinery left a total of	90.87	42.4
Coal per I. H. P. in terms of the guarantee lbs.	0.968	1.122
Thermal efficiency per cent.	21.88	18.87
Average r.p.m.	160.5

Test of gas engine, belt-driven dynamo, and suction gas plant at Dollar.

In this test Scotch anthracite was used, having the following percentage composition: Ash, 4; moisture, 2.4; volatile matter, 6; fixed carbon, 87.6. Its caloric value was 15,138 B. T. U. per pound. The producer was completely filled to a predetermined level when the actual full-load test was commenced, and at the end of the test the fire was clinkered and the ashes removed before measuring the final weight of fuel to make up the predetermined level in the producer. The engine had a 10-inch cylinder with 21-inch stroke, and the governing was on the "hit and miss" principle.

Duration of test hours,	7:30
Total coal consumed lbs.	163
Average coal consumed per hour lbs.	21.733
Average load on dynamo kw.	16.803
Average mean pressure of indicator diagrams lbs.	70.5
Average I. H. P.	32.06
Assuming 85 per cent mechanical efficiency, the B. H. P. was	27.25
Coal per kw. hour lbs.	1.293
Coal per B. H. P. lb.	0.797
Coal per I. H. P. lb.	0.677
Thermal efficiencies—	
Indicated work ÷ B. T. U. in coal per cent.	24.95
Assumed actual H. P. ÷ B. T. U. in coal per cent.	21.26
Electrical energy ÷ B. T. U. in coal per cent.	17.60
Average r.p.m.	229.6
Average explosions per minute	109.0
Efficiency of dynamo and belt drive, about per cent.	82.6

SHIPPING PORTABLE GASOLINE ENGINES.

Under the official classification No. 26, of the Official Classification Committee, portable gasoline engines are accepted by the railroad companies coming under the jurisdiction of this committee only on a minimum rate of 8,000 pounds each, in less than carloads. This is at the second-class rate. In carloads they are accepted at fifth-class rate, minimum weight 24,000 pounds. As a matter of fact, it takes a pretty large portable gasoline engine to weigh 8,000 pounds. Some of the smaller units weigh only 2,500 pounds, while we recently saw a traction engine of but 15 H. P., which weighed only 9,100 pounds. Probably the average weight of portable gasoline rigs is less than 5,000 pounds. Under the present ruling, therefore, the shippers of portable gasoline engines are compelled to pay freight, on an average, of nearly double the actual weight. This is equivalent to doubling the freight rate.

The stand of the railroad companies is that these outfits are bulky and require a sufficiently large amount of space to

justify such a charge. In other words, if a shipment occupies a third of a car, the railroad must make its rate on the basis of what one-third of a carload shipment ought to weigh, irrespective of what it actually does weigh. And as the minimum weight of carload shipments is 24,000 pounds, therefore a portable gasoline engine must be billed at 8,000 pounds, inasmuch as it is supposed to occupy at least one-third of a car.

As a matter of fact, we have seen cars in which goods were packed under and around portable engines, so that the railroad did not really lose the use of one-third of the car.

Such a ruling as this will operate very materially against the shipment of portable gasoline rigs, at least as such, and will compel the shipper to take the engine off the trucks and ship the trucks and engine separately, thereby paying less freight on the total shipment (in case the outfit weighs less than about 5,000 pounds) that if he had made ship-

ment all connected up. This requires more work and more crating on the part of the shipper, and requires the purchaser to remount the engine and make the connections. Not only this, but it necessitates much more handling on the part of the railroad company, and takes more room in the cars than if shipped connected up. But notwithstanding the extra work of handling and the extra space re-

quired by separate shipment, the railroad company makes a less charge for handling it in this way than if sent as heretofore. Mr. E. C. Gill, 143 Liberty street, New York City, is Chairman of the Official Classification Committee, and we have taken up the matter with him and endeavored to secure an explanation of the attitude of the railroad companies on this point.

FACTORS IN GAS ENGINE DEVELOPMENT.

The development of the gas engine has passed through a cycle almost similar to that of the steam engine and dynamo. While the very first steam engine that revolved belonged to the turbine form, it was centuries before the steam turbine came again into practical use. The same thing is true of the dynamo; in its earlier forms it gave out an alternating current, which with great ingenuity was straightened out by the commutator and the direct current was used for years before it began to be replaced with the alternating current.

The gas engine in its earlier days was primarily intended to utilize waste gases. This was the first idea of its inventors, who realized the large amount of waste heat that was being lost in the atmosphere from different kinds of furnaces, and the gas engine seemed to be the only thing which offered any solution to the problem. When, however, the gas engine first began to be used for power, it was considered necessary to have the finest selected anthracite coal to produce gas of the right quality and it was developed in the smaller powers along that line. It was not until those interested in the gas engine went back to their first principles of using waste gases that the gas engine really began to be any great factor in engineering. So long as the gas engine was compelled to use high priced city gas, it could not hope to compete with the steam engine.

The use of blast furnace gases opened up to the gas engine one of its widest fields. It is said that for every 150 tons of cast-iron that are made in the blast furnace, it gives out 21,000,000 cubic feet of gas. In this case, the blast furnace be-

comes in reality a gas generator and the question might well be asked, when these gases are used to run powerful gas engines, which is the by-product of the blast furnace, the cast-iron or the gases given off?

The producer gas has opened up another field for the gas engine, for, with the aid of the gas producer, the power of the engine is derived directly from the coal. About five years ago, the first practical suction gas producer was put upon the market in Germany, but at the present time, there are a number of firms manufacturing them in this country. The apparatus consists briefly of a generator in which the coal is burned, a blower used for starting the fire and raising the heat in the generator to proper temperature for the production of gas, a coal hopper which allows charging during operation, a vaporizer for the generator of steam, a scrubber, consisting of a coke tower with a water spray for washing the gas, a cleaner, through which the gas is filtered.

The effect of these developments has been to increase the use of the gas engine for many purposes and while it is not as yet a formidable rival to the steam engine, on account of its many inherent defects, it possesses features of economy which are very attractive and which must necessarily engage the attention of the power user.

Another development of this class of engine is the gas turbine, of which, as yet, little is known, but if it can be made to operate successfully, it should be one of the most efficient and economical machines for converting the stored energy in the coal into useful work.—*The Practical Engineer.*

THE SMITH GAS PRODUCER.

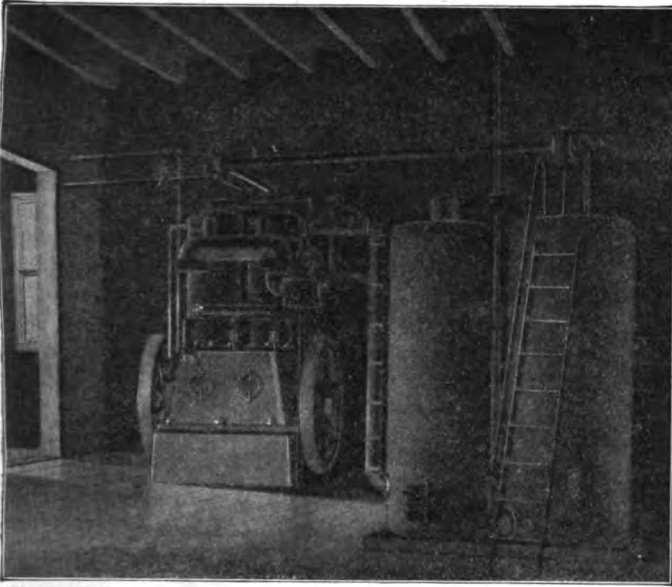

The Smith Suction Gas Producer.

One of the latest and most approved types of suction gas producers now on the market in the United States is the one manufactured by the Smith Gas Power Company, of New Lexington, O. This producer differs very radically in many particulars from the usual type of suction gas producer, and is, therefore, of more than usual interest.

One of the principal difficulties met with in the operation of the ordinary type of suction producer plants is that of maintaining a sufficiently uniform quality of gas to insure the maintenance of the correct explosive mixture at the engine cylinder. This is especially the case where the load is at all variable, and is often so serious that many makers will not recommend the use of suction producers, unless the load to be carried is fairly steady. The chief cause of this variation in the quality of the gas is that the percentage of steam carried by the blast is not constant, and, as a consequence, the percentage of hydrogen contained in the gas varies accordingly.

In the Smith producer this difficulty is

overcome by the use of a patented regulator, which automatically weighs out the air and water that are to be supplied to the producer, thus holding the percentage of moisture constant for all conditions of load. As a result of this arrangement, the quality of gas being produced is very uniform in heat value even when

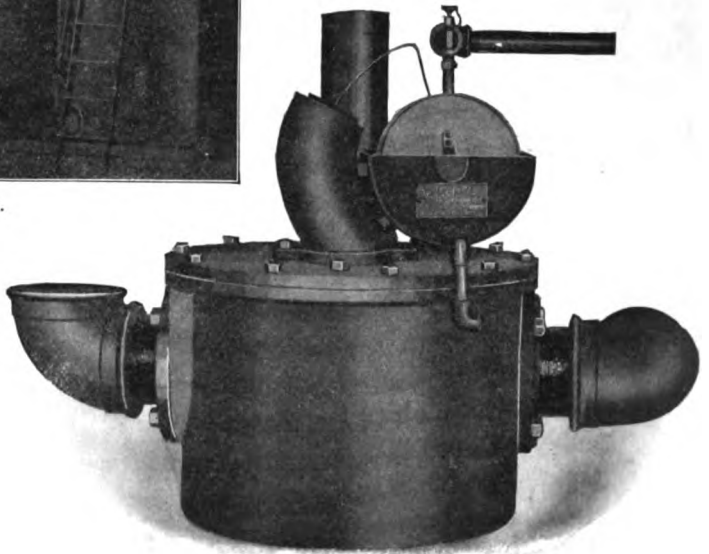

The Regulator and Superheater.

the load is quite variable. This also enables the producer to operate successfully on very light loads, no difficulty being experienced in operating the plant for a long time with no load beyond the friction of the engine. This is quite a remarkable feature in view of the fact that the usual type of suction producer will not operate at all for any length of time on loads less than one-fifth the rating of the plant.

The regulator mentioned is used in connection with a superheater into which the air and water are fed from the regulator to be highly superheated by the gas engine exhaust. In this manner a considerable por-

tion of waste heat from the engine exhaust is returned to the producer and a proportionate amount of fuel saved.

In the producer proper the fuel is supported on a patent swinging grate. This grate, being swung on chains, moves very easily, and makes the removal of ash and clinkers a very simple matter. In regular service the ashes are shaken down once a day and removed from the ash pit once a week.

In these producers the gas outlet is placed very high above the grate. The depth of fuel being so great that accumulation of ash on the grate or small irregularities in the fire do not affect the quality of the gas, but simply shift the active or gas-making zone to another part of the producer.

Above the gas outlet is a fuel magazine of sufficient capacity to hold a day's supply of fuel. The charge of fuel is introduced at the top through a water sealed charging door of special design.

In the scrubber, instead of the usual coke filling, wooden slats are employed, which present the advantage of never requiring renewal, being easily cleaned by flushing an extra amount of water through the scrubber. After passing the scrubber the gas is further purified by a moisture separator placed near the engine, which removes entrained moisture and dust from the gas. This is similar in construction to the moisture and oil separators used in steam plants.

Aside from the low cost of fuel, which is usually about one-fourth the cost of steam or gasoline, there are many reasons why plants of this kind are to be preferred. As

compared with steam power, it is smokeless, requires no stack, is not affected by scale or bad water, does not require insurance or inspection, does not require a licensed engineer, can not explode and destroy life and property,

The cost of maintenance on these plants is extremely low, the only parts subject to wear being the lining and grates. With proper care these should last from six to ten years. The balance of the plant is practically indestructible.

As compared with gasoline, the chief advantages are greater safety and lower fuel cost.

In some cases of especial hazard the reduction in insurance rates alone is sufficient to cover the entire cost for the producer. In one instance the rate allowed was one per cent less than could be secured for any other kind of power, gas, gasoline, steam and electric power all being available.

It has been urged as an argument against the suction producer that it is sometimes desirable to use the producer gas for heating furnaces and the like, as well as for power, and in this case a pressure producer would be necessary. By the use of a simple attachment, the Smith Gas Power Company are able to take from their regular type of suction producer any amount of gas that may be required for heating purposes without interfering in any way with the operation of the engine supplied by the producer.

One of these producers, fitted with the attachment mentioned above, can be seen in daily operation in the company's shops at Lexington, O.

SCOTCH GAS ENGINE TESTS.

During the last of June there was to be held in Glasgow, by the Highland and Agricultural Society of Scotland, a series of tests of gas producers and gas engines, the object being to bring the practical working of this form of motive power under the immediate notice of agriculturists and others to whom a cheap and simple source of power is of the utmost importance.

Each exhibitor was to show two complete plants, consisting of suction gas producers and accessories, and suitable

engines of between 5 and 8, and 15 and 20 H. P.; and while no award will be made, full official reports on the tests will be recorded. The time to start from cold; and the consumption of fuel at full and half load for hour hours' continuous run was to be observed. The fuel was Scotch anthracite provided by the society. In the entry form, the cost of the plant—a very important item—is included; while the frequency with which the producer requires charging and cleaning has also to be stated.

A GASOLINE DRIVEN ROCK DRILL.



Gasoline engines are being brought into new kinds of service every day. They have long been used in mines in operating hoists, air compressors, etc. The accompanying illustration shows a rock drill operated by means of gasoline.

The cylinder is four inches in diameter by four inches stroke. The explosion in the cylinder gives the direct blow to the drill used in mining operations. Gasoline and air are admitted to the cylinder by means of a carbureter, which has been especially designed for underground work, making it impossible for gasoline to leak or evaporate into the atmosphere, an event which would be very dangerous in a mine. The ponderous plant of air compressors, engines, etc., of the usual type of power drill are replaced by this small plant weighing about 75 pounds. The box shown consists of the six cells, which furnish the current to ignite the charge in the drill cylinder, also a high tension spark coil, etc. A copper case carries sufficient gasoline for a day's

operation. Three gallons of gasoline will operate the drill a ten-hour shift. The complete outfit weighs about 300 pounds. The cylinder is air cooled.

Ventilation is a most important topic in connection with mines, and about the greatest objection to the use of gasoline motor of any kind in a mine is the fact that the engine must be supplied with fresh air, and the exhaust gases can not be allowed to escape into and vitiate the atmosphere. In this drill there is attached to the exhaust pipe a section of fire-proof sectional hose with detachable couplings, by means of which the exhaust is carried into and through a pipe or tubing which leads along the floor or walls or roof of the tunnel to the surface. Therefore, instead of vitiating the air in the mine the drill is an aid to ventilation, keeping up a circulation of air.

For the information given, and the use of the illustration, we are indebted to The Gasoline Rock Drill Company, 218 South Fourth street, Philadelphia, Pa.

THE EFFICIENCY OF GAS ENGINES.

In the course of investigations intended to aid in the establishment of standard methods of rating the performance of internal-combustion motors, the Verein Deutscher Ingenieure has recently published in its *Zeitschrift* communications from a number of eminent engineers of experience in this line of work. Among the contributors to this valuable discussion we note the names of such men as Stodola, Riedler, Meyer, Schoettler, Ehrhardt and Wagener, and the points brought out are of value and interest.

Professor Stodola points out that our notions of gross and net efficiency in gas engines are derived from similar terms in connection with steam engine practice, the net power being simply the gross indicated power less the frictional losses in the machine, and the mechanical efficiency being the ratio of the net to the gross power. He also refers to the so-called thermo-dynamic efficiency, this being the ratio of the work developed to that which would be obtained from the same quantity of heat supplied to an ideal machine working through a predetermined cycle. The ordinary idea of the thermal efficiency of a heat engine of any type is the ratio of the heat equivalent of the work developed to the total amount of heat supplied in the fuel.

In the practical application of these values, however, various opportunities for differences in opinion and practice occur. Thus in the case of the steam engine there are other losses besides the friction of the mechanical parts, and among these Professor Stodola calls attention to the loss by throttling the exhaust, and to the leakage losses. In the case of the condensing steam engine the question also arises as to the deduction of the resistance, frictional and otherwise, of the air pump, especially when this is driven independently, either by steam or electricity. In the case of the two-cycle gas engine there is also the resistance of the compression pump to be taken into account, and comparable results can not be expected unless these points are consistently treated. It is a question whether the actual resistance in the compression pump should not be separated from its frictional resistance, and Professor Stodola maintains that the air pump should be in-

dicated as well as the working cylinder, and that the difference between the power indicated in the cylinder and the resistance indicated in the air pump be taken as the true indicated power. In this position he is supported by the precedent of Professor Schroeter in his tests of the Diesel motor, and by Mr. Dugald Clerk in his practice.

This point is of especial importance in the determination of the mechanical efficiency of the gas engine, since the ratio of the indicated power to the brake power will be very materially affected, according as the indicated negative work on the air pump is deducted or not.

Professor Riedler maintains that the indicated efficiency of a gas engine should be based upon the indicated power in the cylinder, regardless of the work to be overcome in the compression pump, and cites the similar practice in steam engineering, in which no deduction is made for air pump resistance, the resistance of the air pump being wholly included with the mechanical resistance of the engine. Professor Meyer differs in this respect, but very properly considers it a matter of minor importance, since the thermal efficiency of the gas engine should be based upon the brake-power, as the only true measure of efficiency.

Professor Riedler calls attention to the fact that the resistance of a compression pump operating in connection with an internal-combustion motor is by no means analogous to that of an air pump working in connection with a steam engine, the latter acting to reduce the back pressure in the power cylinder.

So far as the actual practice goes, it is a matter not so much for discussion as for unification, and it is most desirable that the system of reporting gas engine tests should be standardized in such a manner as to render the results scientifically and practically comparable. It is of little use to state that such an engine has a thermal efficiency of 30 per cent; for example, if it is not known upon what basis the efficiency is computed, and of two such indefinite statements one can not tell in any way which is the better machine.

In the codes of the American Society of Mechanical Engineers for testing steam and gas engines, the question of the resist-

ance of the pumps is not stated to be deducted from the indicated power in determining the efficiency, although all the steam consumed by the auxiliaries is directed to be charged to the steam consumption of the engine, this steam being measured separately, when possible, for convenience in analyzing the performance. In both steam and gas engines the power is stated to be either indicated or brake, but no hint is given as to whether the indicated power is simply the power indicated in the main cylinder or whether it has had the air pump or compression pump resistance deducted.

As a matter of fact, practice is contradictory in this respect. In steam engine trials it has been customary to take the indicated power as simply that shown by the indicator in the cylinder, and to allow all other resistances to be included in the internal resistances of the engine, and deducted by the operation of measuring the B. H. P. This practice undoubtedly acts to give a higher thermal efficiency and a lower mechanical efficiency than would be the case if

the indicated negative work in the pump were deducted from the indicated power before making the computation. In the case of internal combustion motors it appears to have been the practice to deduct the work done in the compression pump, and Professor Meyer calls attention to the fact that the negative work in the compression pump was deducted in the case of the tests of the Ericsson hot air engines, as well as in the tests of the Brayton petroleum motor and the Diesel motor, these various engines covering practically the entire period of practical work with the internal combustion motor.

The matter is one of importance, mainly because it is desirable to have the reports of trials in comparable form, and it is probable that with the increasing practice of using engines to drive electrical generators, the efficiency will be determined upon the actual horse-power developed, and measured by the electrical output, the use of the indicated power as a basis of efficiency being entirely superseded by the more practical ratio.—*The Engineering Magazine.*

MOTORS FOR BOATS IN WESTERN NORWAY.

United States Consul Cunningham, at Bergen, Norway, asks, in a recent report: "Is it the 5 per cent ad valorem duty which has kept most American manufacturers from attempting to secure part of the trade in motors in Western Norway? So far as I know, only two American companies have attempted to do business in Norway to date. One manufacturer of kerosene motors, with an agent at Bergen, placed 22 American motors of from 3 to 22 H. P. last year, and an agent of American gasoline motors in Christiania has also sold some gasoline motors, but he has not given this section much attention.

"The installation of these auxiliary motor powers in Norway has been very slow in comparison with what it has been in Denmark and other countries. Two years since, perhaps, not a fishing boat was equipped, but the general belief is that motors will be rapidly adopted from now on. One small town, very much in advance of others in this particular, has, during the last year and earlier, installed over 70 kerosene motors in boats of different kinds.

"Not many motors have been installed in

fishing boats, but those that have been have given a great impetus to the demand, and it will not be a great while, if those in use continue to give satisfaction, before every fisherman who is able to do so will equip his boat with auxiliary power of some kind.

"The business has scarcely been introduced, but no more fertile field can be found than in Norway, if these kerosene and gasoline motors are all that is claimed for them. The west coast has a fleet of several thousand boats engaged in fishing, and the fishermen are fully awake and will adopt such methods as will increase their returns by increasing their catch or bringing it to market quicker. In this country, with its great coast line and numerous fjords, boats are used where in most other lands some form of carriage or railroad is used. Wood is brought great distances to market in sailing boats. One of these recently installed a 22 H. P. American motor. Many business people travel almost entirely by water. The clergyman, in visiting his parishioners, must have his boat, and police and other officers of the government travel the same way. Some of these have equipped their

boats with small motors with very satisfactory results. Then the pleasure seekers and residents of islands doing business elsewhere, not in small numbers, would

welcome motors that could always be relied upon. Probably no place furnishes a greater variety of wants for good motors than Western Norway."

THE CLEANING OF BLAST FURNACE GAS.

In a paper on this subject, read before the Iron and Steel Institute by Alex Sahlin, of London, the author said:

"The rapid development of the gas motor during the last five years has given new value and importance to the gas escaping from the blast furnace, previously often described as waste gas. This 'waste gas' has now become a potential source of energy, which, rightly used and husbanded, should, together with the gas from the coke ovens supplying the blast furnace, suffice for the carrying out of the entire series of converting and finishing process which transform the ore into marketable steel products. The gas leaving the blast furnace carries with it a varying amount of gritty dust, which has proved a more serious obstacle to the successful operation of large gas engines than any mechanical imperfection in the construction of these engines. Successful efforts to remove the dust from the gas used in the gas engine have in a practical manner demonstrated how wasteful and imperfect have been our previous methods of utilizing the valuable blast furnace gas. It required the appearance

of the gas engine to compel improvements in the methods of cleaning and to stop, at least partly, the waste which had been permitted to go on from year to year.

"The gas for the power plant is drawn from the clean gas main and is passed through one of two electrically driven fans sprayed with water and discharged into a second smaller dryer, whence the gas, now dust free, practically speaking, is sent to the engines. The size of this plant depends on the quantity of gas required for power purposes. A fan cleaning 10,000 cubic feet per minute and using 8,000 gallons of spraying water per hour requires about 65 H. P. and will supply gas engines of from 5,000 to 6,000 H. P. The pumping of spraying water will require about 3 H. P. additional. The cooling water used in the cleaning processes is delivered into double settling and cooling ponds and is thence lifted by centrifugal pumps into a standpipe or water tank, from which it is returned by gravity to the cooling plant. On top of the tank may be arranged trays for additional cooling of the water."

ITEMS.

J. R. Cullup & Bro., Purdy, Mo., are operating their 50-barrel flour mill and corn meal burrs with a 50 H. P. gas engine and suction gas producer. They say that their average load is about 35 H. P., and they use 340 pounds of charcoal per 10 hours. Charcoal costing \$6 per ton is used, making the daily cost for fuel \$1.03. This is a saving is fuel of about \$5 per day as compared with the steam plant which was formerly used.

The last Congress passed an agricultural appropriation bill calling for the study of agricultural appliances and power. Prof. C. J. Zintheo, formerly of the Ames (Ia.) State College, has re-

ceived the appointment of agricultural implement expert under this department. A portion of the work of this department will be experiments with farm motors to determine the cheapest motive power for farm use. Tests will be made with various kinds of internal combustion engines, including gas producers and producer gas engines.

At South Stratfordshire, England, a power gas company has about completed a Mond gas system to supply cheap gas over a district of 120 square miles. The gas has a low calorific value, and gas equivalent to 15,000 H. P. is to be supplied to the district

A N S W E R S T O I N Q U I R I E S
--

It is our purpose to answer in this column inquiries of general interest which relate to the gas engine or its accessories. The questions will be answered in these columns only, and we reserve the privilege of refusing to answer any question which is not, in our judgment, of interest to the subscribers of THE GAS ENGINE.

All matter intended for this department should be addressed to The Editor of THE GAS ENGINE, Blymyer Building, Cincinnati, Ohio. The name and address of the sender must accompany the inquiry in all cases as evidence of good faith. The initials only of the sender will be published, together with the postoffice and state.

Write on one side of the paper only, and make all sketches and drawings on a separate sheet. Mark each sheet with the name and the address of the sender.

I have a four-cycle $4\frac{1}{2}$ inch by 5 inch horizontal engine, with a 220-pound flywheel 28 inches in diameter, and makes 630 r.p.m., with $2\frac{1}{4}$ -inch compression space. It is run on city water gas. (a) What would be the H. P. of this engine? (b) Is the flywheel in proportion? (c) Is not the compression space too great? (d) How would $\frac{3}{4}$ of an inch go? E. E. C.,

San Francisco, Cal.

(a) $3\frac{1}{2}$ to 4 H. P., if properly designed with large compression as at present, probably not over 2 H. P. (b) It is about right. (c) Yes, the compression space should be not over $23\frac{1}{2}$ cubic inches. (d) This depends entirely upon the volume of the valve chamber. If the valves open directly into the compression space, it would be too small, and the space should, in this case, be 1 7-16 inch long.

I am building a vertical two-cylinder 4 x 4 engine. Which way should the crank shaft be made? The crank pins opposite each other or on a straight line? (b) What horse-power will this engine have at 1,000 r.p.m.? (c) Are the following proportions right: 1 7-16 inch crank shaft, cylinder walls 7-16 inch thick, connecting rod $7\frac{1}{2}$ inches long, compression space 1 inch?

F. F., Chicago, Ill.

(a) Opposite for two-cycles, in line for four-cycles. (b) 11 H. P. for two-cycle,

8 H. P. for four-cycle. (c) No, make shaft $1\frac{1}{4}$ inch diameter; walls, 5-16 to $\frac{3}{8}$ inch, according to iron; connecting rod, 8 inches long; compression space, 1 3-16 inch for two-cycle.

On starting my engine it does considerable smoking at the muffler, does not seem to fire every charge properly, runs for a while, when it commences to make an awful loud report from the exhaust muffler, also seems to check, or lose speed. Can you tell me the cause, also the remedy? All connections and batteries seem all right. The engine is a pumping engine and works all right except the exhaust. It does not carry a very heavy load. Any information you can give me will be appreciated.

L. D. M., Selma, Ala.

This looks very much like a weak battery. It may be due to poor mixture. The exhaust explosions are always caused by misfires.

I would like to ask the readers of THE GAS ENGINE which engine is the best for automobile use, the water-cooled or the air-cooled? And will the air-cooled keep cool enough to run good without the aid of fans? I am going to buy an automobile soon or buy the parts and construct it myself, and am rather in favor of the air-cooled engine, but am not posted on them. All the cars around here are the water-cooled. I would be pleased to hear from any one who is posted on this subject.

J. W., Gibson, Ia.

Both water cooled and air cooled engines are showing good service. An air cooled engine larger than $3\frac{3}{4}$ bore should not be operated without a fan, and we consider that an engine even of this size or smaller is better with a fan in extremely warm weather.

Please give me the size of the admission port into the crank-case, also the size pipe connection to carbureter of a three-port two-cycle engine, $5\frac{1}{2}$ bore by 6 stroke. The cylinder inlet port to be $3\frac{3}{4}$ by $\frac{5}{8}$, exhaust port $3\frac{3}{4}$ by $\frac{3}{4}$; the area of these ports is

2.34 and 2.81 square inches respectively. They have been made large purposely for high speed, that is, 590 r. p. m. which is a speed of 5,000 feet per minute for the inlet, and 5,000 for the exhaust. I had in mind to make the crank-case admission port $1\frac{1}{8}$ by $1\frac{3}{4}$, and use an $1\frac{1}{2}$ pipe connection for the carbureter, the area of which is 2 square inches. The smaller dimensions of the ports above refer to the direction of piston travel.

G. H. C., Sparrows Point, Md.

We should prefer to make the ports as follows: Inlet $3\frac{1}{2}$ by $\frac{3}{4}$, exhaust $3\frac{1}{2}$ by $1\frac{1}{8}$, crankcase inlet $1\frac{1}{8}$ by 3, pipe to carbureter 2, exhaust pipe $2\frac{1}{2}$. You may speed the engine to 750 r. p. m. if you wish.

(a) Will you tell us who make the "Brush Mixing Valve," and where we can get them if you know? They are used on the Cadillac automobile, but whether they have them or buy them we do not know, and thought you could help us out. (b) Also what make of carbureter do you think best for two-cycle engines? (c) What is the best way to make a muffler for two-cycle engine that will not give much back pressure on the engine?

(a) The Brush mixing valve is made, we believe, by Charles A. Strelinger Company, Detroit, Mich. (b) We can not express opinions of this nature in these columns. (c) Two or three concentric cylinders of Russia iron make a good muffler.

AUTOMOBILES AND MOTOR BOATS IN CHINA.

In a recent issue we published a report from the United States Consul at Hang-chau, China, regarding the prospect for stationary gasoline engines in that country. This same official recently reported on the outlook for automobiles and motor boats, as follows:

"Practically speaking, there is no extended market for automobiles in China. In the average Chinese city it would be impossible to use a machine, and there is no prospect of any improvement in the near future of a character to promise any trade. In Shanghai a good many automobiles are in use, and their popularity is increasing. It may almost be said that an automobile boom is on in that city. There are many people there who can afford automobiles and who are accustomed to spend money in such ways, but the demand will be limited to Shanghai City, and machines suitable for city work rather than country touring are the ones needed.

"As to motor boats, the prospect is very bright. The whole of China is a network of canals and rivers, upon which motor boats, especially boats of light draft capacity, can be operated. Within the past few years the accepted mode of travel has been by house boat, towed by a steam launch. Where the regular lines of steam launches do not run, the old-time house boat with a yuloh or scull is employed. These boats are very slow and grow more and more unpopular. It will be many years before this travel is displaced by railroads, and in the meanwhile there is a growing favor for

power boats, both for the private ownership of those who are compelled to go about considerably in China and for a more or less public service. The motor boat as it is now made in the United States is practically unknown in China. In Shanghai and other prominent trading points on the coast there are a number of modern small launches, but the great interior is practically untouched. The Chinese people who have sufficient means to buy such things are turning more and more in the direction of modern western inventions, and I have no doubt that a consistent and persistent campaign in behalf of American motor boats, of cheap and substantial grades, would result in building up a great and permanent business. The need of motor boats is here, and the Chinese and foreigners domiciled here are appreciating the need. So far there has been little done to meet it. There is an agency for one line of American launches in Shanghai, and several other firms there have a working arrangement with concerns in the United States for the sale of boats, but the business is not pushed, and there will probably be little change in the situation until the manufacturers of the United States go at the matter systematically and with energy. The boats sold in Shanghai are usually of high grade and high prices, and most people of moderate means do not realize that there are motor boats within their reach. It is quite possible that a strong advertising campaign, even in English, would result in a good start for a motor boat boom."

SULPHUR AS A PACKING BETWEEN BED PLATES AND FOUNDATIONS.

C. E. Mink, in *Machinery*, has the following to say regarding the use of sulphur as a packing between bed plates and foundations:

"Running melted sulphur under the bedplate of a steam engine, pump or any other piece of machinery, as a permanent packing between the bedplate and foundation, is not by any means new, sulphur having been used for that purpose for years; but as it has proved in my experience to be the very best material for the purpose of making a perfect packing, the sulphur expanding in cooling so as to fill perfectly the space between the under side of the bed and the masonry of the foundation, I heartily recommend it for that purpose. The method of performing the work is so simple that it can be accomplished by a neophyte if he will follow strictly the following directions:

"Level up the bedplate on iron wedges, placing them at such intervals as will not permit the casting to sag, leaving the space between bedplate and foundation from one-eighth to three-sixteenths inch high. Pack with well-worked clay close all around the

casting, leaving risers or sprue holes at such intervals and of sufficient height to insure the space being entirely filled. Turn the nuts of the fastening bolts home to the casting all around. Melt the sulphur over a very slow fire, taking care that the sulphur is simply hot enough to become fluid. It will run like water. When it is just past the melting point pour into as many sprue holes as will allow the sulphur to run under the bed, and, uniting in one mass, rise and fill all the risers or sprue holes. If run up full while in a fluid state the sulphur will expand in cooling, and all the fastening bolts will be found tight. Remove the clay, chip off the sprues and you have a smooth, neat joint, which will last indefinitely, if the waste oil from the engine or other machinery is not permitted to accumulate around the foundation, for oil will dissolve sulphur. If for any reason the foundation can not be kept free from waste oil, clean the joint and cover it with a coat of paint. If the bedplate is an open one, cover the joint on the inside with a layer of putty, following with a coat of paint."

BLAST FURNACE GAS.

In an article in *The Revue de Metallurgie* by Cr. de Mocomble, on the "Utilization of Blast Furnace Gases," the author says:

"Bearing in mind the figures given in our introduction, it will be readily seen that the utilization of the waste gases of blast furnaces constitutes an immense progress, and that the metallurgical industry will derive great benefits from the substitution for steam engines of internal combustion engines.

"The day is still far away when all the gas produced will be utilized, but it will be admitted, if we consider the remarkable development of this new application, that no metallurgical plant can afford to ignore it if it is not to be distanced by its competitors. The available energy can not always be immediately utilized, but new industries are created where they can be readily developed, Switzerland.

the Niagara, and, nearer us, the Dauphine, afford as many striking instances of this.

"The first gas-blowing engine was tried ten years ago, and four years ago the new 600 H. P. Cockerill cylinder was received with surprise and skepticism. Today 1,500 H. P. cylinders are constructed, giving engines of 3,000 and even 6,000 H. P. Notwithstanding such brilliant results, it might be recalled that in 1895, when Mr. Thwaite suggested his method for the utilization of blast-furnace gas, he met with absolute incredulity. The ironmasters to whom he appealed ridiculed the idea, saying that it was absurd to expect that a gas so poor that it is sometimes impossible to keep it burning under the boilers, would ignite regularly under the conditions which must be met for the working of internal combustion engines. Mr. Riley, the manager of the Glasgow

Iron Company, alone understood that this was not an Utopia, and with an initiative which could not be too highly commended, he replaced the steam engine of the electrical power station by the first gas engine working with blast-furnace gas. This installation, although it only includes a small motor, is nevertheless very interesting, as it gave excellent results and justifies the inventor's statement that 'the moment the fly wheel of this gas engine made its first revolution marked an important date in the history

of the metallurgy of iron.' Since then, how much has been accomplished! But it must be remembered that if the construction of these blast-furnace gas engines has in a few years so markedly progressed, it is due to the cleansing of the gases. The only stationary period recorded at the beginning was due to an incomplete cleaning of the gases, it having been deemed useless to attempt a more thorough cleaning. This cleaning may be considered as the vital question of the gas motors."

SPECIAL GENERATORS FOR GAS ENGINES.



R. E. Type Generator with Flywheel for Gas Engine.

The Richmond Electric Company, Richmond, Va., have just placed on the market a line of electric generators, particularly designed for gas engine service. These generators have heavy accurately balanced fly wheels, keyed upon the armature shaft at the commutator end as shown, leaving the pulley end free for the usual pulley if belted, or for their special flexible coupling if for direct connection. The fly wheel is so heavy that with belt service the impulses of explosion are absorbed and a steady light is obtained if the governor is such as to prevent racing. The fly wheel will not correct a racing governor, but will absorb, as far as all practical purposes are concerned, explosion pulsations. This also applies to the direct connected type in which the flexible coupling permits the fly wheel to absorb the explosion just as it does in the belt type. Quite a number of these generators are running and there have been no complaints of bad regulation. Some of their direct connected generators have been running two years or more, and the flexible couplings show no depreciation or lack of performance. It is, therefore, with considerable confidence that they of-

fer the generators to the gas engine builders for either belt or direct connection. Some think that several cylinders or special engine design is necessary to enable an explosion engine to give satisfactory incandescent light service without a storage battery. This is, however, not the case. Any well designed and well built two or four-cycle single cylinder engine with a delicate and reliable governor will do so with one of these generators.

It is a much cheaper way to obtain satisfactory incandescent light service than to attempt to absorb the explosions in the engine itself. The generator is where the trouble is felt and the best place at which to remove it.

It is to be remembered that a belted installation is much cheaper, and good regulation can be obtained for less money at belt speeds than at slow direct connected speeds. In other words, the fly wheels can be made lighter with belted generators than with direct connected generators and the same regulation ac-



Motor Head.

completed. It is also a fact that the efficiency of a small generator running at 1,200 or 1,500 R. P. M. is better than at the slow speeds of direct connection, and very often all belt losses are entirely made up by the higher efficiency of belted

machines. The company, therefore, does not recommend direct connected machines except as the sizes go up in the neighborhood of two hundred lights and over. These machines run all the way from about twelve to five hundred lights.

"ECHOES FROM THE OIL COUNTRY."

One day a man who had charge of a mechanical establishment dropped in to see a friend, and by some means the conversation drifted on to the cost of power needed to run various plants. This friend was in the gas engine business, and from the various necessities of his business he had often to consider the cost of power under varied conditions.

"Do you think I could save any money if I undertook to run our works with a gas engine?" the visitor asked.

"How many pounds of coal do you use to the H. P., and what does it cost you?"

"I really don't know how many pounds. It costs me \$1.50 per ton, and last year we paid \$1,800 for it. We have more power than we ever use, as the engine will give us 200 H. P. on a pinch, and we do not average more than half of that."

"I am not much of a coal man myself; but, of course, you buy your coal by the car load. When you buy it that way do you get a long ton or a short ton for your \$1.50?"

A puzzled look came into the visitor's face. "That is something that I never thought about, and I can't tell. I just thought that a ton of coal was a ton of coal, if I ever thought of it at all."

"We will call it the short ton to be sure, and figure back. Eighteen hundred dollars will buy you 1,200 tons, and 300 working days to the year would give you 4 tons a day. This gives you 800 pounds per hour, and using 100 H. P. would mean that you are using 8 pounds of coal per H. P. hour. Don't you think that is a little more than should be used with reasonable economy?"

"I am not much of a steam engine expert, but if anyone is getting near what we read about, I must be away off. There is one thing about a steam plant, though, that I never liked. You have to guess at too many things. When you speak to the fireman, it is the engine that is at

fault, or the boiler is not rightly designed for the kind of coal he is using, or some other equally good excuse. Of course, he is doing the very best that anyone could do under the circumstances that are not under his control. When you go after the engineer, you find that the engine is in fine condition, although he may not think well of that particular style. If there is anything wrong about the power end of the place, it must be at the boiler. When he hints that he can supply you with a very good fireman instead of the one you now have, you remember that some relation of his has been around looking for work. In the end you get back to where you started, without having done anything. I guess everyone who is using only a small amount of power is in the same fix. What do you think about it?"

"Put in a gas engine, by all means, and you will be at the end of your troubles. At the last end of some kinds, and at the front end of others. There is one thing sure, though; you will never use two or three times the gas you ought to without hunting down the cause.

"With a good gas engine capable of running your works you should get a B. H. P. for about 80 cents a month, with a reasonably steady load and using natural gas at 25 cents per thousand cubic feet. It should not go over a dollar even if you put in a 200 H. P. engine and have an average load of 100 H. P. only,

"If your gas bills should come in for a few months at about \$90, and then they should change to \$105, I am thinking I can see you going around with fire in your eye and a determination to find where those six dollars went to or know the reason why they have to be paid."

"I don't think you should find fault with a man for wanting to get all that is coming to him," said the visitor; "six dollars saved in one spot is quite an item."

"It isn't the size of it that makes you

so willing to try to save it, though, but the fact that it is so much easier to run down than the coal bill is. It takes both money and time to test a steam plant, and after you get it tested it takes more money and time to keep it up to where the test shows it can be worked. In most plants it is not not even known what the costs of the power plant are—that is, day by day. With a gas engine all that is changed. All that is needed is a meter on the gas line. With this arrangement any man who can read the meter and do a simple sum in arithmetic can tell what his power costs him, minute by minute, if he wants to know. Even if he is not at all inquisitive, the gas company will be very regular in sending in its bills, and it is very easy to compare one month with another.

"If there is a increase in the gas bills, nothing but finding a leak between the meter and the engine will save the reputation of the latter. Indeed, when you come to think of it, there are several things that may make a difference without it being the fault of the engine. For instance, the quality of the gas may change; an improper oil may be bought because it costs less, or simply because the importance of the proper kind of oil is not thoroughly understood; the man in charge may be turning on more gas than is necessary and so not get perfect combustion; the engine may be 'tinkered' with, so that it is not in proper adjustment; the engine may not be kept clean inside; it may be run too hot or too cold. The engine should not be blamed for any of these things, but it often is until the maker demonstrates that the blame is being put in the wrong place. I think, taking all the steam engines in this country that are under 50 H. P., that twice as much fuel is used to run them as would be needed under good conditions. I have heard of places where tests have shown that 30 pounds of coal were being used per H. P. hour. If an engine is supplied with 8 pounds of steam for each pound of coal burned, such an engine would use 240 pounds per H. P. hour; or just about ten times too much. Just shut your eyes and try to imagine the actions and language of a man who should get a gas bill that showed that his engine was using 120 cubic feet of gas per H. P. per hour. No need to urge him to have it fixed. He will attend to that without any urging, and

also see to it that the maker of the engine is given to feel a realizing sense of the depths of degradation to which his engine has sunk.

"When people get to where they are singing the praises of those who have benefitted the world by improving gas engines they should not forget the magnificent work of the gas meter. It should at least share the honors."

"From that I seem to understand that you think the gas engine has succeeded; because most of us are too shiftless to keep a steam plant in proper shape. Is that your idea?"

"Human nature is human nature. Very few people go out of their way to hunt for trouble. Let me tell you a little story.

"Jake was a steam engine man. He had been all his life, and he was not a young man. One day his employer bought a gas engine, and it was part of Jake's business to run it. It ran day and night just as the steam engine had done. Jake hated that gas engine as only a steam engine man can hate one. He cursed it loud and long; he cursed the man who bought it; he cursed the man who made it; he cursed the man who 'got it up,' and he was not at all particular who heard him do the cursing, either. He had to see that it kept going. If it stopped in the night he had to get up and start it again. He gave it just as little attention as he could and hold his job, and it was not many months before it had to be sent to the shop for repairs, and while it was there Jake had the steam engine and boiler to again do the work. The owner told the foreman of the shop not to hurry about the repairs, as he thought it would be a good plan to let Jake have a chance to cool off a bit before the engine was sent back, and it was allowed to stand for some time before anything was done on it.

"One day Jake met the foreman on the street. 'Is that engine 'most done?' he inquired. 'No, not yet,' answered the foreman, as he hurried away. He did not want to hear Jake's opinion of the engine. He had heard it too often to find it interesting.

"In a few days Jake came to the shop inquiring about the engine, and he pressed his inquiries to the point where he found that the work was not started,

then he expressed his opinion of the shop and of the foreman.

"'Why,' put in that worthy, when he could get a chance, 'I thought I was doing you a favor by keeping it here as long as ever I could.'

"'Favor nothing,' snorted Jake. 'Do you think I have nothing to do nights but set up with a darned old steam boiler First it blows for low water and I have to dig out of bed and go down half dressed for fear it will burn the crown sheet, and after the blamed pump condescends to take hold, and I lay down on the bench while she fills up, the first thing I know the water is coming out of the safety valve. By the time I get the water

down and the steam run up and the engine started again I am so mad and wide awake that it isn't any use going to bed any more. I wouldn't work for a man that didn't have git up enough in him to have a gas engine, and if you don't soon get that one finished I will come in and these folks will have to have another foreman when I get through with you.'

"It was the human nature working."

"I certainly will have to consider putting in a gas engine," said the visitor as he started away.

It "just happened" that it is so easy to keep track of the fuel cost of a gas engine. W. Osborne, in *The American Machinist*.

THE WESTERN TWO-CYCLE ENGINE.

The Continental Engine Company, Fisher Building, Chicago, are manufacturing a two-cycle reversible engine, chiefly for marine purposes. The engine has a bore of 3 inches and a stroke of $3\frac{1}{2}$ inches, and is claimed to develop 2 H. P. at its normal speed of 750 R. P. M. The weight is 90 pounds. The cylinder, crank case and piston are made from a tough, close-grained iron, and all parts are carefully machined. The connecting rod is of gun metal and has an adjustable bearing at the crank pin end. The crank shaft is a drop forging. Through the center of the shaft is drilled an oil hole reaching to the crank pin, which is thus oiled directly from a compression grease cup attached to the forward end of the crank shaft outside of the fly wheel. The main bearings and the eccentric for operating the pump are also oiled by compression grease cups, while a sight feed oil cup is provided for oiling the pistons and rings.

The launch motor is one of the two-cycle type, and the most successful reversing motors on the market. Any experienced launch owner who has "fussed" with many of the mechanism for reversing the shaft or screw knows what frequent disappointments and annoyances are caused by these devices. The motor runs equally well forward or backward. The speed is another feature, as it will run consistently at 850 R. P. M. This engine is constructed strictly from their own designs. It is built in the most rigid

and perfect manner, with the aid of tools, especially designed for that purpose. The gasoline engine at its present stage of development is usually built with the ordinary tools found in every machine shop. Such tools are adapted to a wide range of general work, and while they may answer for some parts of a gasoline engine, they do not meet the requirements of accurate cylinder and piston construction, so necessary for small engines. Hence the necessity of the special tools.

The gasoline passes to the crank case through a mixer valve of the company's own design. The mixer valve closes automatically when the engine is shut down, and has a special mixing plate which prevents the motor from missing at the higher speeds. Jump spark ignition is used. The cylinder and head are water cooled, the water being circulated by a plunger pump driven by an eccentric off the crank shaft. A special feature of this engine is the exhaust condenser, which is attached to the side of the engine and into which the hot exhaust from the engine is led. The exhaust here comes in contact with the cooling water and is therefore much reduced in temperature, this action at the same time causing a partial vacuum which aids action of engine. The engine is started by rocking the fly wheel a few times and then moving it backward against the compression in the cylinder. By means of the reversing lever the engine may be started in

either direction. The speed is controlled by the same lever, which changes the point of ignition, and it is claimed that by this means alone the speed can be va-

ried from 100 to 900 P. P. M. The propeller shaft and ball thrust bearing for same are features that are certainly very desirable for speed work of all kinds.

THE RELATIVE ADVANCEMENT OF SPARK SYSTEMS

In several articles I have read on ignition circuits, the authors have stated that the jump-spark required more advancing than the make-and-break, but in no case under my observation was a satisfactory explanation given as to the reason it should be so. The main reason for this is that, in the jump-spark system the advancing arrangement controls the charging as well as the discharging of the coil.

As soon as the contact is made a current is sent through the primary of the induction coil, charging it. As soon as the coil is magnetized, the vibrator discharges it, producing a spark. This charging and discharging continues as long as the current flows. To advance, you change the position of the contact. Therefore, the advancing arrangement for a jump-spark controls the charging as well as discharging of the coil.

In the make-and-break, the advancing mechanism controls only the discharge. The charging is done in some other part of the circuit. For instance, in a two-cycle engine, a convenient place to charge the coil can be found on the pump mechanism, if a plunger pump is used, the plunger coming up and making a contact near the top of the stroke. No matter how or where the contact is made, it must be some time previous to the time of discharge and should be continued, so that the spark-points in the cylinder break the current. In this case, the spark-points only are controlled by the advancing arrangement, the coil is always charged when you are ready to separate the sparking-points and, as the discharge is instantaneous, when once set they will fire in exactly that same position at any speed.

In the jump-spark, however, the time taken to charge the coil must be taken into account. This is found to be approximately 1-250th of a second, from the time the circuit is closed to fire the mixture. So, while the make-and-break is instantaneous, it takes 1-250th of a second for the jump-spark to act.

Now, let us consider two engines exactly alike in construction, one make-and-break, the other jump-spark ignition, both running at 300 r. p. m., and set the advancing levers so that they fire in the same position relative to the piston. The jump-spark advancing lever would have to be placed slightly ahead of the make-and-break advancing lever to fire in the same position. This would be 300-60 equals 5 revs. per sec., 1-250x5 equals .02 of a rev. ahead of make-and-break.

Now, let the speed be increased to 1,200 r. p. m. The proper advance for 1,200 revolutions would be, say 30 deg. on the crank-circle, that is, .083 of a revolution. Therefore, the make-and-break would be advanced .083 of a revolution.

The jump-spark, however, would have to be advanced more, on account of the time it takes to charge the coil. This would be:

1,200-60 equals 20 revs. per sec. 1,250x20 equals .08 of a revolution.

Therefore, to get an actual advance of .083, we would have to advance .08 more, or a total of .163 of a revolution. So we see that in this case we would have to advance a jump-spark approximately twice as far as a make-and-break, to get the same speed. It has been proven, however, that this advance is only apparent. Actually, the sparks take place at the same relative position of the pistons.

From this we can see that if both engines were set at about 30 deg. on the crank-circle in advance, that is, if both engines are turned over by hand, the spark will take place as soon as there remain but 30 degrees on the crank-circle required to complete the stroke. Now, let them run at 1,200 revolution each, by varying the load on each. It will then be found that the make-and-break is still firing at 30 deg. while the jump-spark is firing at about the top of the stroke. So it will be seen that a jump-spark automatically retards itself.

This accounts for the successful opera-

tion of the non-advanceable make-and-break, while with the jump-spark it would be an impossibility.

In this connection I will relate the experience I had at the Importers' Salon, and which was the cause of this article. While strolling around looking at the different makes, I happened to stop at the chassis of a well-known firm, who use a non-advanceable make-and-break. I asked the salesman the reason for such an arrangement, and he replied that the heat of the spark at the higher speeds automatically advances the explosion. Realizing that this was theoretically so, I replied that it was possibly negligible in practice, especially under the conditions he had. They had a good spark to start on, and as the dynamo speeded up the current increased.

He replied that it would be a very

simple experiment, which I could try for myself with a jump-spark arrangement. Take an engine adjusted normally and note the advance for a certain speed. Now, weaken the tension in the vibrator-spring (this, he claimed, weakened the spark), and note the advance again. The increased advance, he claimed, was due to the weaker spark, therefore, a hotter spark will fire the charge earlier than a weak one. This experiment sounded well at the time, but I found out that he not only weakened the spark on weakening the tension of said spring, but also changed the time of charging the coil. Therefore, the change of advance could be figured out, as I have done above, if the time of charge be known, and we see it would not be due entirely to difference of sparks, which would be practically negligible.—*The Motor Boat.*

JUMP SPARK COIL SUGGESTION.

The following suggestions on jump spark coils is reprinted from the catalogue of the Schug Electric Manufacturing Company, Detroit:

See that the coil is located where it will have ample protection from excessive heat, dirt, grease or moisture. If the coil is placed too near the engine the heat of the engine will melt out the wax, causing the insulation to become weakened. If necessary place the coil in a box. Dash coils are so constructed that they, of course, do not need to be placed where they will be protected from the weather. Do not use more than four or six dry batteries, or more than two or three storage cells.

If the contact points get uneven, dress them down with a very fine file. When the contact points are burned away, do not have any composition metal put on for contacts, as this will not do. Nothing but the best platinum will do. New contact points can be furnished, and owner put them on, or entirely new contact screws and vibrators can be furnished.

Do not connect the battery to the coil until you have either connected the secondary terminal to the plug or else connected a short piece of wire on to the terminals, leaving only a short gap between the terminals so that the current can

jump across the space. These coils are not made to use on an electric light circuit.

If the screws which hold the fittings on the coil box are turned, the connections will be broken and the coil ruined. Do not change the adjustment on the coil until you are sure that it is necessary. Before changing the adjustment, providing the engine will not start, see that the batteries are in good condition, that there is gasoline in the tank and that it is turned on. One weak battery in a set will prevent the rest of the cells from giving good results. With a suitable ammeter a test can be made which will enable you to pick out the poor cells.

In testing to see if the coil gives a good spark, remove the spark plug, laying it on the engine frame with the secondary wire connected, being careful that the secondary terminal is not touching the engine frame. When this is done turn the engine over until contact at the commutator is made, which should cause the coil to work, giving a spark at the plug. See that the plug is not badly sooted.

Good rubber covered wire should be used for battery wire and extra heavy rubber covered wire should be used from the coil to the plug.

To properly adjust the coil set the vi-

brator close to end of core, and have just sufficient tension in vibrator spring to cause it to work rapidly enough. If the vibrator is set so that it is too stiff it will use more current than is necessary.

If the vibrator is set so that it will be too stiff, or if the contact screw is screwed down too tight, or if the contact screw does not touch the vibrator, it will not work.

A HIGH COMPRESSION GAS ENGINE.

An eminent English gas engine expert recently made a test on a high compression gas engine brought out last November by Messrs. Crossley Bros. and in his report said, of the engine:

"Up to the present, when using coal or producer gas, the compression has been limited to about 110 pounds per square inch. Compressions higher than this are apt to heat up the charge to such an extent as to cause premature ignition—that is, the charge ignites before the end of the compression stroke. Messrs. Crossley have recently brought out a new type of engine, in which the compression is carried to over 200 pounds per square inch and in which premature ignition is prevented by drawing in a small quantity of water during the suction stroke. The engine tested was of the electric lighting type, with an extra heavy fly-wheel and an outer bearing, which, to some extent, accounts for the mechanical efficiency being lower than in their ordinary type of engine. The engine cylinder was 14 inches diameter with 21-inch stroke; and the duration of the test lasted for 6 hours and 45 minutes. During this time the engine ran perfectly smoothly, without either premature ignitions or back explosions. The calorific value of the gas was determined at intervals in a Junkers calorimeter, the average value being 578 B. T. U. per cubic foot at a temperature of 60 degrees Fahr., and under a barometric pressure of 30 inches. The clearance volume was 0.243 cubic foot; the cylinder volume being 1.872 cubic feet, and the ratio of expansion 8.7. The maximum pressure in the cylinder was 528 pounds above atmospheric pressure; the volume at maximum temperature being 0.247 cubic foot. The average pressure during suction was 1.9 per square inches below that of the atmosphere—that is, 12.8 pounds per square inch absolute. The compression curve equals 6,508 foot-pounds, and the expansion curve 17,610 foot-pounds.

During the suction stroke, the injected water appears to be turned into steam, which becomes superheated during compression. Heat passes into the charge from the walls until a pressure of about 160 pounds per square inch is reached, when the charge appears to be as hot as the walls. The heat additions prove that the whole of the available heat—that is, the total heat of the charge, less that rejected into the water-jacket, has appeared at the point of maximum temperature. Taking the total heat of the gas used per explosion as 100, the indicated work is 37.4; the heat rejected into the water-jacket is 29, and that into the exhaust 33.6. The percentage of useful work is the highest thermal efficiency which has to my knowledge been obtained in a test."

The gas used in the trial was that supplied by the Manchester Corporation, a sample of which was analyzed and found to have the following composition:

	Percentage by Volume.
Carbon dioxide	2.14
Heavy hydrocarbons.....	6.80
Hydrogen	42.90
Carbon monoxide.....	14.99
Marsh gas	30.93
Nitrogen	2.24
	100.00

One hundred volumes of the gas consumed 117.81 volumes of oxygen; and its heating value (by calculation) was 582 B. T. U. per cubic foot.

Did it ever occur to you that if you place rubbish, particularly metals, on top of your batteries, that they are sure to be short-circuited?

Did you ever think that the ignition bar on your make and break ignition might wear in the course of several years, and that it might need adjustment to maintain the time of the ignition?

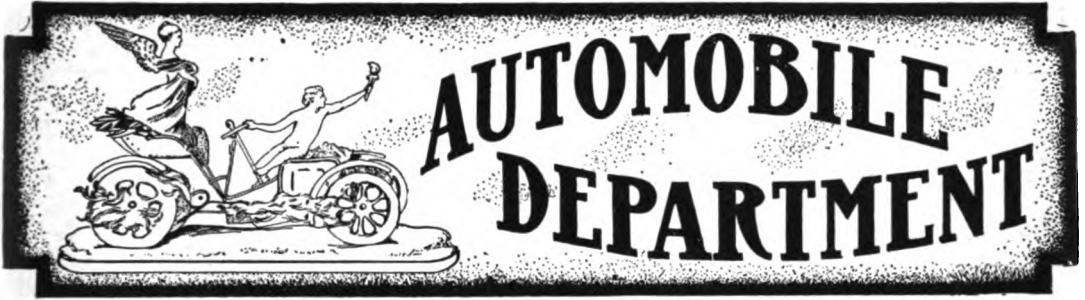

A year or so ago the racing machines being built were announced as having 80 to 100 H. P. motors, and people doubted it. This year the talk is of 180 to 200 H. P. motors. Where will this end?

It may be a good joke on the man who is behind, but the crowd does not call it good sport or an exciting race when the winner finishes from a quarter to half a mile ahead of the next man. An efficient handicapping and classification system would render many races more exciting and interesting. But no one as yet has evolved the correct system.

An English farmer reports that after using horses, a steam plow, and a motor plow having a 14 H. P. kerosene oil engine, the cost of plowing by that last named method was much less than either of the others. Two and a quarter acres were plowed daily. This required nine horses at an expense of \$5.47, three men at \$2.16, three boys at 72 cents, a total of \$8.35. For the steam plow the cost was \$9.25; \$2.70 for coal and transportation of coal and water, and \$6.55 for the machine. With the kerosene driven plow the total cost was \$4.44; \$1.88 for driver, 60 cents for plowman, 24 cents for lubricating oil and \$2.52 for fuel.

The ability to start up a four-cylinder engine on the switch is a great convenience and a safeguard against damaged arms or wrists, as all will admit. It is not every time that a start is made that the engine is so obliging as to come into action on merely pressing over the switch. This may be accounted for in two ways: First, the absence of a combustible change in any one cylinder, and, second, an incomplete electric circuit to any of the sparking plugs. The remedy in the first place is to flood the car-

bureter, and with the starting handle give the crankshaft half a dozen turns with the ignition switched off. For the second complaint the remedy is more simple, for it only requires the ignition lever to be quickly advanced, and then brought back again. This has the effect of establishing the circuit and causing the desired spark. Unless the ignition lever is brought smartly back again, the next cylinder to fire will receive its spark too early, and there is every possibility of the engine being reversed, with consequent shock to all the working parts.

Some exhaust muffler trials which were undertaken in France recently gave interesting information on this subject.

Compared with previous trials held two years ago, it is found that the power absorbed by the muffler has been reduced from eleven to five per cent., while in some cases it is as low as two per cent. However, it was found that a muffler can be devised which will actually increase the power of the engine. When the exhaust is discharged freely in the air the gases leave at such a high velocity that they meet with a great deal of resistance from the atmosphere, which is the cause of the noise, and if this velocity can be reduced just sufficiently to suppress this shock and air resistance, it obviously follows that the engine must develop a little more power. Experiments made by attaching a long pipe with several bends to the exhaust pipe, and discharging the exhaust alternately through this pipe and directly into the air, showed that there was invariably a difference in the power developed by the engine, the increase of power with the long bent pipe being 1.4 per cent. The effect of the long pipe is to reduce the temperature of the hot gases, which leave at a much lower velocity than from the short exhaust pipe.

ALCOHOL AS A FUEL FOR MOTORS.*

The best fuel for explosion motors is the fuel containing the greatest amount of heat convertible into useful work; it should not be too volatile, for if it is too rapidly vaporized the loss from evaporation and the danger from fire is increased. Another important consideration is carburation. The difficulties of designing a carbureter are greatly increased if the fuel is, in part, easily vaporized, leaving, however, a non-vaporizable residue—a difficulty that was sorely felt by the pioneers who used surface carbureters. The spray carbureter largely disposes of this difficulty, though not entirely. To be approximately ideal, the fuel should be homogenous; that is, it should not be susceptible of being split up into several components. It is a property of chemical compounds of carbon and hydrogen that, if burned in the presence of a sufficient quantity of air, they are subjected to a sort of condensing action, a portion being burned and the remainder, a tarry substance, being deposited on the cylinder walls, piston head, sparking points and other surfaces inside the cylinders.

Another point is the amount of heat required to vaporize the fuel, a point which is usually overlooked. Those who have suffered from frozen carbureters will realize that in the process of vaporization the hydrocarbon absorbs a great deal of heat. On a test recently made with a carbureter which was not warmed, ice a quarter of an inch thick formed on the tube leading from the carbureter to the inlet. This is, of course, easily overcome; but it gives a good idea of the absorption of heat which occurs during vaporization. This heat must be supplied by the fuel, and if some of the enormous amount of heat that unavoidably goes to waste can be thus utilized, there will be just so much gained.

The ideal fuel should be explosive in widely differing proportions of vapor and air. A fuel which must be kept within a very small range of proportions of vapor and air makes it necessary to use a carbureter designed with extreme care; but if the range of explosive mixtures is wide,

very much is gained, for the carbureter may be of more simple construction and still supply the cylinders with explosible gas. Again, much would be gained in regulating the speed of the motor by regulating the strength of the mixture, rather than by throttling. Thus the motor would run with constant compression and would show increased efficacy over running on the throttle. A wide range of explosive mixtures would also mean a more complete combustion, and the result would be cleaner cylinders and spark plugs and less trouble from short circuits, less odorous exhausts and less deposit in cylinders.

The three fuels in common use are gasoline, benzol and alcohol. By benzol is meant not the chemically pure substance, but the commercial benzol, best known as crude naphtha; that is, naphtha from which the naphthaline and sulphur compounds have been extracted. As to heat contents, it may be stated that gasoline and benzol are, approximately, equal. Their heat of combustion per unit of weight is 10,200 or 10,250 units, while alcohol compares badly, with but 5,500 heat units. In this respect gasoline and benzol have a great advantage, but the question of greatest importance is: What percentage of the heat contained in a given fuel can we utilize in the form of mechanical energy?

In this country (England) very few experiments have been made with alcohol, and it is necessary to turn to Germany for data. French data on alcohol is of little use in this connection, because in that country the alcohol used for fuel has invariably been mixed with from 30 to 50 per cent of benzol, because the motors used were built to use gasoline, and, though not really suited to use alcohol, answered very well indeed when a mixture of alcohol and benzol was used.

The heat efficiency of a gasoline motor is not as high as many might believe; under favorable conditions a brake test will give 20 per cent at the fly-wheel. While this is not a particularly good result, it is much better than can be obtained from the steam engine. When alcohol is used, however, an efficiency of from 30 to 32½ per cent can be obtained under the same conditions; that is, under a full load and at the most ad-

*From a paper by Dr. Ormandy before the Western Section of the Scottish Automobile Club.

vantageous speed. Under half load the efficiency of the motor using gasoline drops off greatly, and the alcohol motor under half load will also drop off greatly, even more than the gasoline motor, if the jacket of the cylinder is not kept at about the temperature of boiling water—212 degrees Fahr. If this is done, however, the alcohol gives much higher efficiency than the gasoline, and this is of great importance because the explosion motor is usually run under light load about 90 per cent of the time, and there is a growing tendency to use high-power engines throttled down to meet the requirements. Under such conditions alcohol shows up exceedingly well, and gasoline and benzol very badly.

The next question is the range of explosibility, and here again alcohol has a vast advantage, having a range nearly twice as great as that of gasoline. That means that the power of the motor may be governed to twice the extent that is possible with gasoline, without throttling, and that throttling need not be commenced until the power has been cut down to something like 25 per cent of the maximum by simply altering the strength of the mixture.

The homogeneity or otherwise of the fuel is also an important matter. Ordinary gasoline is a mixture of hydrocarbons in varying proportions; on the contrary, alcohol is homogenous. If a thermometer is put in water and the water heated, it will begin to boil at 100 degrees Centigrade, and will continue to boil at that temperature until it has all evaporated, because water is homogenous. If gasoline is treated in the same way it will commence boiling at about 80 degrees Centigrade, but as part of the liquid evaporates, the boiling point of what is left rises until, when the liquid is practically all gone, the temperature will rise as high as 222 degrees Centigrade.

Obviously a mixture of so many different boiling points and of such varying degrees of vaporization is far from ideal as a fuel.

Pure benzol, or benzine, boils at about 80 degrees Centigrade, but the crude article, which must necessarily be used for fuel, may boil at any point from 80 degrees to 200 degrees—having, in fact, about the same range of boiling points as gasoline. It consists of a mixture of three or four chemical substances boiling at widely different temperatures.

Alcohol is, like water, chemically homogenous, commencing to boil at about 80 de-

grees Centigrade and finishing at the same temperature. Here again alcohol has a very great advantage.

The subject of vapor tension—that is, the volatility of the fluid—is not so easily treated. A high vapor tension means that the liquid is easily vaporized, which is a desirable attribute when starting a motor. But a high vapor tension also means great inflammability, which is by no means so desirable.

Alcohol has a much lower vapor tension than gasoline or benzol, and it is more difficult to start the motor with alcohol on this account. But if a carbureter can be made that will work satisfactorily with alcohol, the constant vapor tension will be a great advantage, as there will never be trouble from "stale gasoline." Once set, the carbureter is always set. The alcohol bought in one place will require exactly the same amount of air as the alcohol bought somewhere else. The whole question turns on the possibility of working out a carbureter that will vaporize alcohol so that it can be used to start the motor. It is generally stated that such a carbureter is a practical impossibility, but doubtless this is because so few experiments have been made in this direction. As a matter of fact, it is not an impossibility, for a carbureter has been made that would, on many occasions, start a cold motor on alcohol. Though there were many occasions when the motor refused to start, the fact that on some occasions it did start on alcohol proves that the thing can be done.

(To Be Continued.)

One of the largest locomotive factories in the country has just begun the manufacture of gasoline automobiles.

On June 2d the mechanical branch of the Association of Licensed Automobile Manufacturers discussed the subject of carbureters. Papers were read by Hiram Percy Maxim, D. Ferguson and H. W. Alden. It was admitted that the carbureter had not been perfected, and that a method of obtaining, automatically, the best quantity and quality of explosive mixture at variable speeds and under varying road conditions, had not been secured in a perfect degree. The same subject will be considered at the next meeting, July 7th.

LENGTH OF MOTOR.

In comparing the motors seen at recent shows with those of several years ago, one very decided difference is seen. The former design was long and slim, whereas present ones are short and of considerable diameter. At first thought this is assumed to be due to a change in the relation of bore to stroke, and this is to some extent true, for while in the past the tendency was to make the stroke longer than the bore, there are a number of instances where now the bore is greater than the stroke.

A more likely explanation, however, is that the great demand for high power in a small space has forced designers to shorten the connecting rods and that connecting rods of less than twice the stroke length (4 times the crank length) are more common than those of greater length. This at once brings up the question of advantages vs. disadvantages, and some wonderment as to whether this shortening process may not be carried to an extreme. With the motor under the body, there is little limitation in the matter of length, particularly with the single cylinder form, but with double cylinder opposed crosswise the body or with vertical engines in front, length is decidedly objectionable and shortening at once begins. If the short length is gained by short stroke, larger bearings must be provided, but if it is gained by shortening the connecting rods, then the increased angularity of the connecting rods deserve serious attention. It is common salesmen's talk that in a horizontal engine the weight of the piston gradually wears the bottom of the cylinder and the buyer is led to believe that in a short while a new cylinder will be needed if he would prevent the piston from wearing its way through the bottom and dropping out into the road. It is well-known, however, that a bearing will not wear if a film of oil is constantly maintained between the two metal surfaces and it is also well-known that light loads will not force out the oil, and therefore it should be apparent to anyone that the bottom of a horizontal cylinder is the part least likely to wear, for so long as there is any oil on the piston at all, the bottom will be well lubricated. Oil cups

are commonly placed on the top side, which feed the oil where wanted, and it is generally admitted that the horizontal motor lubricates better than the vertical. This argument against horizontal engines is therefore extremely ill founded.

It is a fact, however, that cylinders sometimes wear out of round, but the cause must be looked for elsewhere. It is not the weight of the piston that causes the trouble, for pistons seldom weigh more than 10 pounds in an auto engine, and frequently but one-third of this. When we remember, however, that a $4\frac{1}{2}$ diameter piston has an area of over 15 inches, and that it is exposed to pressure of 200 or 300 pounds per square inch, and that a short connecting rod must of necessity work at a considerable angle, we see at once that the pressure against the side of the piston as a result of this angle must be many times that of any possible weight of the piston, and that if cylinders do wear this is the cause of the wearing. Mr. A. L. Clough, in an able article in one of our contemporaries quite recently, not only makes this matter very plain, but gives figures to show that the pressure from this cause may readily be 100 times as great as the weight of the piston.

Forewarned is forearmed, and a proper understanding of a difficulty is first necessary if we are to properly meet and overcome it. Now that we clearly see the cause of this objectionable wearing we can design a remedy. It is quite evident that if the piston was provided with a straight piston rod and a cross head, as is a steam engine, there would be no wear on the piston, but the wear would be transferred to the cross head. This would not remedy matters, but it makes plain that if the connecting rod was long enough to have practically no angularity while working, the objection would be removed. This is, of course, impossible, but is an argument in favor of longer connecting rods. Since, however, space is limited, the short connecting rod may be considered as a necessity, for it both secures compactness and light weight and is, therefore, the least evil even if not a necessary one.

There is, fortunately, another solution.

It is well known that four cycle gas engines do not reverse, and it is clearly apparent that the work done on the compression stroke is quite small as compared with the working stroke. If, therefore, we can decrease the angularity of the connecting rod during the working stroke, we accomplish the result desired, even though a considerable increase of angularity is found during the compression stroke. To attain this result all that is necessary is to set the crank shaft to one side of the center line of the cylinder. Assuming the engine to be horizontal and the working stroke to carry the top of the fly wheel from the cylinder, as is customary, the crank shaft should be set below the cylinder centers. As a result of this a considerable portion near the beginning and near the end of the working stroke finds the connecting rod substantially parallel and coincident with the cylinder center, thus relieving the cylinder walls from any pressure whatever. At the extreme beginning and end, the angularity is to one side, an amount dependent, of course, on the distance between the shaft center and cylinder centers, while the center portion of the working stroke shows an angularity to the other side. On the compression stroke the angularity is all one way, and is in-

creased, but, as stated before, the compression pressure is not great, particularly at the middle of the stroke where the angularity is greatest and the weight of the piston works against this increased angularity in a favorable manner. This solution, therefore, has everything in its favor and nothing against it, and is much superior to a considerably lengthened connecting rod.

How much the shaft should be away from the cylinder center line is next to be considered, but this seems to be rather a matter for the designer to determine in each individual instance than for a general article like this. If set too far down the connecting rod will strike the open end of the cylinder at the bottom, and the loss on the compression stroke may be greater than the gain on the working stroke. When the necessity for a more compact engine brought this matter to the writer's consideration, eight years ago, a difference between centers equaling one-third of the crank length seemed to meet all requirements best in an engine having bore and stroke equal and connecting rods three and one-half times the crank length. This arrangement has given excellent satisfaction, and no considerations have arisen of sufficient importance to require a change.—C. E. Duryea, in *The Cycle and Automobile Trade Jour*

C O M P R E S S I O N .

Few motorists thoroughly understand why the gas should be compressed before it is fired, the first impression being that the work entailed would not be likely to be compensated for by the advantages obtained. However, this prior compression is of the greatest importance—in fact, were it not for compression, the gasoline car would not be in existence, and gas engines would be buried away with many a so-called freak or retained only for exhibition purposes.

The earliest forms of gas engines, of the non-compression type, used to draw in a charge during the first half of a down stroke. The inlet valve was then shut and the gas fired, doing work on the piston for the remaining part of the stroke. On the up stroke exhaust took place.

Then it was suggested that the charge should be taken in during the whole

stroke, the piston caused to return and compress the charge ready for firing and expanding throughout the whole stroke. In an engine of the same dimensions, then, a whole stroke was given for filling the cylinder and for getting the work out of it again on the next stroke.

To get the maximum amount of work out of a given quantity of fired gas, a maximum amount of heat must be converted into work, and as little as possible allowed to pass to the cylinder walls, jacket, piston and exhaust. It follows, therefore, that the surface of the cylinder wall and piston face, with which the hot gas is in contact, should be reduced to a minimum. In the non-compression engine the surface was large, compared with that in the gasoline engine as we know it now. In the old type of engine a great deal of heat was lost in this way, which is nowadays converted into use-

ful work. Another cause of high efficiency is that when the charge is fired under compression the initial temperature is high, but falls rapidly for a small movement of the piston, thus still less heat is lost to the jacket. The more closely packed the charge is the more rapid and complete is the combustion, and consequently less heat is lost in the exhaust.

With the old engine the best firing mixture was composed of about 17 parts of gas to 100 of air, while at present the proportion is 8 to 100; that is to say, the fuel consumption is halved. In theory it would seem that there was no limit to the compression pressure, but it must be noted that increasing the compression increases

1. The liability of self-ignition.
2. The liability of leakage.
3. The stress on the parts.
4. Difficulty in ignition.
5. Difficulty in lubrication.
6. Difficulty of starting.
7. Difficulty in running the engine slowly.
8. Size of flywheel.

Most of these increase with the size of the engine.

Some little time ago some very interesting tests were made of an engine with different compression pressures. In the first test, with a compression of 60 pounds to the square inch, 20.8 B. H. P. was developed, the consumption being 22 cubic feet of gas per B. H. P. The compression was then raised to 90 pounds to the square inch, and 24 B. H. P. was obtained, the consumption being only 20.75 cubic feet per

B. H. P. hour. The engine speed in both cases was the same.

High compression is by no means synonymous with good compression. A leak, resulting in poor compression, means that on the suction stroke inert gas is drawn in through the leak, on the compression stroke some of the charge is lost and on the firing stroke useful gas is wasted. Poor compression is thus the chief cause for an engine failing to maintain its power, and to keep an engine in good trim the compression should always be maintained at its maximum.

The compression is dependent on the atmospheric pressure, which, of course, varies with the altitude. This means that there is a slight falling off in compression, and consequently in power, as the car climbs. This is practically negligible in the case of a car in England, but may be worth considering in these days of proposed flying machines.

On about the highest road in England (neglecting mountain railways) the compression of an engine registering 90 pounds to the square inch at sea level registers only 84 pounds to the square inch. If, at the same time, the atmospheric pressure varies with change of weather, etc., there might be quite a noticeable decrease of power. It is quite possible, by variations of atmospheric pressure as suggested, for the compression to vary between 70 and 90 pounds to the square inch in any engine. This, in a four-cylinder engine, means quite a large variation in the power.—*The Autocar*.

GASOLINE PROPELLED RAILWAY CARS.

Hardly a day goes by that we do not see notices in the daily newspapers of the fact that the railroad companies are conducting experiments along the line of gasoline propelled railway cars. For suburban and short-haul passenger and freight traffic, such cars are expected to solve a problem hitherto causing the railroad officials some considerable thought. Not only the larger railroads, but also the interurban trolley lines have been investigating this class of car.

The St. Joseph Valley Traction Company has been running a car between La-Grange and Middleboro, Ind., which car

is 34 feet long and is equipped with a four-cylinder Walrath gasoline engine directly connected to a Sprague generator.

The engine has a capacity of 70 H. P. at 325 r.p.m. and the current is fed to four 35 H. P. motors on the trucks and to an auxiliary storage battery of 120 cells. The latter are so arranged that excess current is fed to them automatically when the motors are not taking it all, and current from the battery is used for the abnormal requirements when starting the car and getting it up to speed. The engine also drives a small air compressor which is used for the air breaks

and for starting the engine. The generators may also be run as a motor from the storage battery for this purpose.

The cooling of the jacket water of the engine is accomplished by circulating it through 800 feet of $\frac{3}{4}$ -inch automobile radiator pipe and thence through a supply tank of 190 gallons capacity. The jacket water is circulated by means of a pump and two 42-inch fans revolving in a horizontal plane furnish a draft through the radiator coils to assist in cooling the water.

The Union Pacific Railroad recently built a car which started at Omaha for a tour over the country, going to the Pacific Coast, then eastward over a southern route, through the middle west, then to the Atlantic Coast, then to Washington and back to Omaha.

The C., H. & D. Railroad has also been added to the list of companies which have taken up the matter of gasoline propelled cars. Certain it is that in the very near future there will be quite an extended use of this class of car.

DIFFERENCES OF THEORY AND PRACTICE.

A correspondent in *The Automobile* has the following to say relative to the difference in theory and practice:

An interesting study of the most favorable conditions for the operation of explosion motors has recently been published by Charles Faroux, a French automobile engineer, who was for a long time an engineer in an American street car company.

One of the striking facts met with in the study of explosion motors is that there is a very wide difference between their theoretical and their practical efficiency, the difference often being as much as from the unit to the double—a variation which is not to be found in any other prime mover. These variations arise from the hypotheses used in figuring theoretical efficiency. The following are the hypotheses:

- (A) The expansion of ignited gases will be instantaneous and at constant volume.
- (B) The pressure of the exhaust gases will be inappreciably above atmosphere.
- (C) There will be no heat losses, through cylinder walls or otherwise.
- (D) Combustion will be complete.
- (E) Back pressure during inlet and exhaust strokes will be but inappreciably above atmosphere.

(A) It is quite certain that the expansion of the ignited mixture is not instantaneous, the speed of combustion having an appreciable value, amounting to several meters per second, the exact rate depending upon the condition of the mixture. Efficiency increases with the temperature and maximum pressure, but the latter is decreased since

the explosion does not take place at constant volume; consequently temperature and efficiency are affected at the same time.

(B) The second supposition, that the gases escape at or but little above atmospheric pressure, is proved erroneous by every-day experience, and the evidence of the eye is sufficient to show the falsity of such a theory. As the compression takes place in the cylinder itself, the efficiency is reduced to a much lower figure than assumed theoretically. Common sense is sufficient to convince any one that the exhaust pressure will be much above atmosphere, and in high-speed work, when the motors are driven to the maximum speed, there is reason to believe the exhaust will take place at a pressure of five times atmospheric pressure, if not more. Under such conditions the strain on the parts of the engine is, of course, very great.

(C) In the third instance, the fact is that there are great heat losses, and the cylinder walls play an important part in carrying away heat, and, consequently, in reducing theoretical efficiency. The cooling water jacket, or, in the case of an air-cooled cylinder, the radiating flanges, provide a means for carrying away heat enough to prevent the burning of the lubricating oil, without which the machine could not run. The proportion of heat so carried off is often more than 50 per cent of the whole.

Experiments conducted by Mallard and Le Chatelier have shown that this heat loss

is proportional to the quantity $\frac{V}{S}$, S being the wall surface and V the volume of the

mixture. Since S increases as the square of the cylinder dimensions and V as the cube, the loss will be greater as the bore and stroke become greater. In this point, as well as many others, high compression engines have advantages, since for an equal

$\frac{V}{S}$
weight of mixture — is smaller.

Experiments conducted by Aime Witz have shown that the higher the temperature of the cylinder walls, the higher the efficiency of the motor. This is accounted for by the fact that these exchanges of temperature are in proportion to the difference between the temperature of the walls and the temperature of the gases. Thus the action of the jacket or cooling flanges is unfavorable to the attainment of the highest efficiency, but, unfortunately, it is a necessary evil.

(D) With regard to the supposition that combustion is complete, Mr. Witz has

proved that 15 per cent or more of the gases is frequently unburnt; this, of course, causing a loss of efficiency. No argument is necessary to prove this.

(E) As to the losses through back pressure during the aspiration and exhaust strokes, it may be said that these are due to mechanical imperfections, which, though to some extent unavoidable, have lost much of their importance in modern motors.

There remains one source of loss to be pointed out. The compression takes place in a dead space, which, after the exhaust stroke remains filled with burned gases, which dilute the fresh charge, thus decreasing the value of the mixture, especially near the point where ignition takes place. This fact impelled Griffin to add two strokes to his motor, one for the aspiration of cold air and the second for its expulsion, thus scavenging the cylinder thoroughly. The thermal efficiency of the six-cycle motor thus constructed was very good.

THE MOTOR CAR IN ENGLISH LAUNDRY SERVICE

The commercial wagon in America has had an up-hill road to climb; it started the ascent of conquest about three years ago; its march has been rather slow, but it is succeeding, and, while the pace was snail-like at the start, it is now quickening, and the entry of each succeeding firm into the manufacture of the commercial vehicle quickens the pace and aids the cause.

This initial slow progress was due mainly to two causes. The majority of American manufacturers were too busy making pleasure vehicles to bother experimenting along the commercial line. Each season found them behind in spring deliveries, and it was impossible to expect they would forsake this fruitful field for others less known. Commercial vehicles were not fairly treated by business men at the outset. The business man, ignorant of the gasoline engine, as well as carbureter, transmission and other important parts of the motor car, imagined that his horse driver was capable of handling a steering wheel and manipulating a couple of levers and as many pedals. He was right to an extent, but herein lay the cause of the solar plexus blow the commercial wagon received at the hands of many business men. The wagon was not properly handled. Many were run for

weeks at a time without seeing the repair shop for little adjustments and repairs. The business man forgot that a stitch in time saves nine, and that with commercial wagons a dollar in time more often saves ninety-nine than nine.

Break-downs came fast and furious. The carbureter was not well adjusted or the motor properly lubricated, and the car stalled, necessitating sending horses to tow it in. Speed gears were changed without proper precaution, and the stripping of a gear meant nearly a week's delay, during which interval changes were taking place in the business man's mind regarding the relative reliability of the motor as compared with the horse. In nine cases out of ten the horse was given preference and commercial motor black-eyed.

The driver was never blamed. He could not possibly be to blame. For years he drove one, two and often four-horse wagons, and was capable of handling as many more. The owner never for one moment considered the delicate machinery plant hidden beneath the bonnet and wagon body. The system of ignition was not considered, nor was it thought necessary that the driver should possess a knowledge of the rudiments of electricity. The same was true of

all other parts, and while the first commercial wagons were running the gauntlet it often looked as though the beginning of the end was near.

But all the business men were not so; some there were who realized that even machinery is limited to loads and speeds, and that it, too, will wear out. To these men is due much of the credit for safely piloting the business wagon through its swaddling garment period. One or two of these pioneers in the bigger cities hung to the game with a tenacity born of determination; they worked and experimented and did everything to reduce expenses, from buying lubricating oil at wholesale to building separate repair shops and making their own repairs. Others followed their efforts and, while the progress was slow, it became evident that with the education of the driver and the measuring of the possibilities of the car, the commercial wagon was a success in its infant days.

What it has gone through in America it has experienced in other countries, but in no place has it been so favorably received as in England. England, France and Germany are the homes of good roads; France and Germany have used theirs for the pleasure car, but England, with her cities of manufacturing industries and harbors lined with wharves, has wrestled with the commercial problem more than all others combined, and it is not surprising that she has advanced far beyond all competitors.

For several years there have been 2,000 light delivery wagons in use, with load-carrying capacity ranging between 560 and 3,200 pounds. These had, nine months ago, a total mileage of over 20,000,000 accredited to them. At the same time 2,164 business vans were in use; the number of public service wagons for passenger use was 443; the number of heavy hauling trucks 902, and the lighter hauling wagons 599. Since these figures were compiled the numbers have increased rapidly, in some classes they have almost doubled.

The laundry industry in particular has figured prominently in the use of commercial wagons. Both steam and gasoline are used, but the electric, owing to limited mileage, has not come in for much favor. The majority used are gasoline.

It has been found that the motor wagon pays best where more than three single horse wagons were used; in cases of fewer horse wagons the figures were unfavorable,

owing to not enough work coming to it. In big establishments it pays best, as they generally have longer trips and larger loads. The commercial wagon is the greatest gainer in long trips. If a six or eight-mile trip has to be made before deliveries commence it is a great saver, as such trips kill the horse, but permit the motor wagon to find itself.

Among many interesting experiments made by owners, one stands out prominently. The wagon used was a 10 H. P. Rykniel gasoline machine. It made, with a 1,200-pound load, 80 deliveries, traveling 91 miles. The total time consumed was 13 hours and 6 minutes; the time consumed in stoppages, 6 hours and 17 minutes, leaving 6 hours and 49 minutes of actual traveling time, or a speed of 13 1-3 miles an hour. This speed may seem slow, but when it is remembered that there were 80 stops and starts made, the speed at times must have been over 20 miles an hour. Horse wagons were used at the same time over the same route and with the same loads, but required 10 hours more to do the work, and each wagon only carried half the load of that taken by the motor wagon. Several similar tests were made under similar circumstances, with almost identical results.

With another company a 1-ton Milnes-Daimler wagon has covered 8,000 miles in 18 months, a performance which means, counting 26 working days to the month, that the wagon has covered 445 miles each month, or 17 per day for the entire period.

The prices and expense of wagons in England vary from those in America, in that their streets and country roads are equal to our boulevards, meaning a big reduction in tire expenses, but against this must be placed the price of gasoline, which is more than double that in America. With them a 6 H. P. delivery wagon costs \$900 and can carry a maximum load of 560 pounds, with a daily mileage of 30, at an expense of \$2.24, and for an additional 84 cents outlay this performance can be doubled. A two-cylinder 10 H. P. wagon will carry an average load of 1,344 pounds 50 miles each day at an expense of \$3.72, and will double the service for an extra expense of \$1.94. This wagon costs \$1,470. These figures include depreciation, maintenance, storage, driver and insurance. A wagon of the latter class will replace four horses and from two to four drivers, and for a total weekly outlay of from \$21.44 to

\$23.84 it will be seen it compares favorably with horse-drawn wagons.

The accompanying summary is based on an 18 months' service of many different makes of commercial wagons working on streets of variable surfaces and during all

kinds of weather :

	—Horse Power—		
	6	8-16	14-20
Average load, lbs....	450.00	1,345.00	3,000.00
First cost	\$900.00	\$1,515.00	\$2,320.00
Av'ge weekly cost...	13.19	20.48	31.50
Av'ge weekly mileage	180.00	300.00	300.00
Daily stand. chgs....\$.52	\$.78	\$ 1.32

—Motor Age.

A BALL-BEARING CRANKSHAFT.

One of the chief difficulties in the employment of ball bearings to the crankshaft has been due to the fact that it was impossible to get a bearing of sufficient size into position without having to divide the bearing.

In a crankshaft designed by an Englishman, three pieces or sections are used, and they are so designed that a multi-cylinder crank can be built up from them. One piece consists of a crank cheek with half the main journal and half the crank pin; another section is the starting handle end, carrying the gear wheel driving the valve mechanism. The fly wheel end is the third section, and on this is fitted a cone. The weight of the fly wheel is taken by an outside ball bearing, which is supported on the end bearing plate of the engine.

The crankshaft is assembled in the following manner: The crank cheek has on the main bearing portion six slots and projections forming a dog clutch. All are equally spaced angularly, and the face of one projection lies on the center line of the crank pin and the main bearing. Thus if any two of these pieces are put together

they will form a series of cranks in any order of 60 degrees or multiples of 60 degrees without any alteration. It is claimed for this crank that the strength is greatly augmented by the fact that the breaking strain is the shearing strain of the twelve interlocking projections.

The bearings throughout are of equal size as to the main bearings and the connecting rod big ends. The central part of the bearing forms a collar, or ring, around the connecting parts of both the main bearings and the crank pins. This serves to prevent any tendency to outward spreading of the dog clutches in the unlikely event of its occurring.

The parts forming the crankshaft are held together by means of taper-headed and nutted bolts. One such bolt is passed through each of the main bearings and crank pins. The latter are not meshed together as the bearings are, since these serve to register the pins correctly without having to employ dog clutches. Apart from the great strength of the assembled shaft, it is said to be exceedingly light. As to its cost and durability we are not informed.

STOPPING TESTS—MOTOR CARS VS. HORSES.

On Wednesday, June 10, on the Upper Terrace of the Crystal Palace, London, a series of interesting tests in the stopping power of horses vs. motor cars was arranged and carried out under the direction of Messrs. S. F. Edge & Co. The first test was between a 20 H. P. motor mail van and a carrier's van drawn by two horses. On the first trial of speed the motor van stopped in 8 feet, while the horse-drawn vehicle occupied no less than 28 feet in coming to a standstill. In the second trial the motor van was stopped in 9 feet, while the horse-drawn van decreased its distance to 24 feet 2 inches.

The next test was between a 30 H. P. Napier pleasure car and a light horse-drawn brougham. At the outset the motor car stopped in 26 feet 6 inches, as against 53 feet taken by the brougham. At the second attempt the motor car stopped in 10 feet, the brougham taking 47 feet 6 inches. A third trial was made, in which the car stopped in 18 feet, as against the brougham's 42 feet 10 inches.

In the third test a 15 H. P. Napier was put up against a hansom cab. In the first trial between these vehicles the motor car pulled up in the remarkably short distance of 18 inches, as compared with the cab's

24 feet 6 inches. The difference here was distinctly more than that of being run over and of escaping accident. On the second trial the car stopped in 7 feet 9 inches, the cab occupying 33 feet 6 inches.

By way of variety, a 15 H. P. De Dion and a butcher's cart next took the terrace. The motor car succeeded in stopping in 9 feet 3 inches, as compared with the butcher cart's 50 feet 5 inches. The next test reduced the contrast between the two vehicles to some extent. Still, the motor car had the advantage by a long way, the respective distances being 14 feet 3 inches for the motor car and 38 feet 5 inches for the butcher's cart.

In the concluding test Macdonald brought out his racing car against a trotting sulky driven by Will Bishop. This was a most interesting contest, in which the car going

at speed was pulled up in 24 feet 3 inches, the sulky taking 35 feet. At the second trial the racer pulled up in 26 feet 6 inches, the sulky increasing to 43 feet 6 inches, the speed being about twenty miles per hour.

The proceedings were watched by a large number of influential and interested spectators. We have no doubt the results would have been more convincingly in favor of the mechanically propelled vehicles had a record been taken of the speeds attained in each trial.

This is a form of competition which might be encouraged with advantage, as it educates the public away from the feeling that an automobile is not more safe at its higher rate of speed than is the ordinary horse-drawn vehicle at its less rate of speed, but which can not be stopped so readily.

THE K. & D. IGNITER.

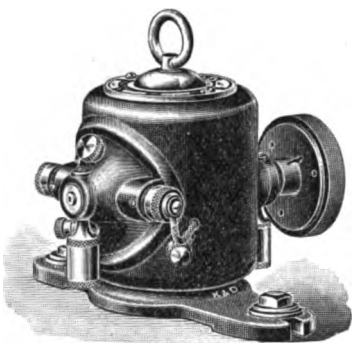

Kendrick & Davis, of Lebanon, N. H., have brought out a gas engine igniter to meet the conditions of single and multi-cylinder engines. The igniter operates through a speed of from 1,000 to 2,500

This generator is self-contained, entirely enclosed and moisture proof, which admits of its use in damp and exposed places. Many novel features are claimed for it, which make it easily cared for. All parts subject to wear are interchangeable and easily duplicated. Bearings are of hard drawn bronze; wick fed oil cups made extra large to hold a sufficient quantity of oil for a week's run; composite brushes of woven wire and carbon.

The weight is 15 pounds and the dimensions are $7\frac{1}{2}$ inches high, 9 inches in length of base, $7\frac{1}{2}$ inches length of shaft. The generators are made with flexible base for tightening belt or regulating friction pulley.

THE DEVELOPMENT OF THE INDUSTRIAL MOTOR.

In his recent lecture on the "History and Development of the Motor Car," the Hon. C. S. Rolls, referring to the use of motor vehicles for industrial purposes, said: "As regards public service vehicles, it was not generally realized that motor buses were running regular services in the streets of London as early as 1834. Yet, not until lately had the omnibus companies been able to procure satisfactory and reliable vehicles. The average earn-

ing capacity of a motor omnibus had been found to be \$200 per week, as against \$84 for the horse omnibus. It was hoped that rapid passenger vehicles running between large towns and the surrounding country would, before long, do away with the necessity for tramways. With regard to light delivery vans, it was to be regretted that some of those which had been tried had not proved altogether satisfactory, owing to makers employing their

standard frames made for pleasure cars, instead of being specially designed to carry the necessary loads of 2,000 or 3,000 pounds. A properly designed motor van, however, would double the range for delivery of tradesmen's goods, and for taking orders. It could run all day and night, if necessary, and would cost nothing when not in use. The use of motor lorries had been further developed and had a big future before them. There were now about 1,000 thousand motor wagons in use in this country, against less than twenty years ago. Motor wagons would act as feeders to the railways, and farmers would be put into touch with towns and markets at present quite out of their reach. Examples were given of the ac-

tual working of motor lorries owned by brewers, millers and others. Makers could show testimony of motor lorries that had run 4,000 miles without the loss of a single working day. With regard to the different forms of motive power, steam was the most suitable for heavy haulage, having a great range of elasticity of power. Motor cars would greatly improve the condition of the streets and of traffic generally. The horse would never become extinct, however, by reason of automobilism. Each had its place in our social and commercial system, but much work of drudgery was now relegated to the horse which could be far better done by mechanical power, and with a great consequent diminution of suffering."

BOOK REVIEWS.

The Motor Launch; How to Build and How to Run, by W. P. Hartford, 138 pages, 6 x 4¾, cloth \$1.00.

This book is written by an amateur boatsman and, as an indication of its character, frequently calls into use "the good old amateur rule of fit and try." In fact, the book is written for the amateur, the man who likes to build his own boat, to put the engine in it, and to operate it himself. We can not agree with everything the author says, as, for instance, that "a steam engine is less trouble than gasoline," nor do we think the precautions against the use of strong language are entirely justified by the gasoline engine's habits. But there is much excellent advice in the hints which are given as to what to do, and what not to do.

After explaining the methods of making the boat model, setting up, planking and finishing the boat, the author discusses engines, mainly gasoline engines, and how to install, care for and operate them.

Gas Producers for Power Purposes, by W. A. Tookey, 137 pages, 6 x 4¾; Boards, London, 50c.

This book is an Englishman's production and its sub-head, "A handbook for the use of purchasers, erectors and attendants," explains its general object. The most valuable portion is part 3, which contains twenty pages on hints

of operation. The first two parts cover the nature of producer gas and the character of producers in general, while the fourth part is an appendix describing sixteen European makes of suction gas producers. The public in America has become very much dissatisfied with books which contain mere catalogue matter, and this portion of the work reviewed is of the nature upon which American book-buyers have set the stamp of disapproval.

Porto Rican sugar plantations are importing a large number of American gasoline engines.

Four Diesel engines, of 150 to 180 H. P. each, operate the pumps at a Russian oil pumping station. The cooling water is cooled by transferring its heat to the oil in the pipe line. As there is so much oil and, comparatively, so little water, there is no trouble as a result.

For railroad pumping service it has been found more economical to utilize about a 15 H. P. gas or gasoline engine and do the requisite pumping in a comparatively short time, rather than use about a 5 or 8 H. P. engine and let it run all day. The saving in the attendants' time and the amount of work he can accomplish after shutting down the larger engine, much more than offsets the increased investment.

TRADE PUBLICATIONS.

Catalogue F, relating to the Barker two-cycle motor has been received from C. L. Barker, Norwalk, Conn.

Special gasoline storage tanks for automobiles are shown in some circulars sent by Janney, Steinmetz & Co., Philadelphia, Pa.

The National motor cars are covered in a new 16-page catalogue from the National Motor Vehicle Company, Indianapolis, Ind.

C. L. Riley, 411 E. First street, Dayton, O., is sending out a sheet showing his 6 H. P. engine, which is also built in 2 and 3 H. P. units.

The Outing Boat Company, 950 Marquette Building, Chicago, have been sending out a very well-printed catalogue of motor boats.

The Columbus (O.) Screw and Machine Company issue a circular of their four-cylinder automobile and marine motor, $4\frac{1}{2}$ -inch bore, $4\frac{1}{2}$ -inch stroke.

"Success" gasoline and distillate engine, built by M. C. Tunison, Los Angeles, Cal., are shown in a new catalogue, No. 5, which the maker is sending out.

The Obermayer Bulletin, of the S. Obermayer Company, Cincinnati, O., is sent free to any foundryman, and contains much that will interest men in that line.

The Fourforone Spark Plug Company, 23 $\frac{1}{2}$ Lake street, Chicago, combine four points in one spark plug, and a circular from the company gives the advantages of the plug.

"Some Eli Facts" is the striking title with a striking cover design on a new catalogue of the Moline Pump Company, Moline, Ill., relating to Eli gas and gasoline engines.

"Schug induction spark coils" is the title of a catalogue of the Schug Electric Manufacturing Company, Detroit. Diagrams for wiring are included. This company is just bringing out a special economy switch which switches first on one set of batteries, then on a second set, then on both sets in multiple series, and

finally on two sets in series. By this means batteries may be used much longer than ordinarily.

"The Humming Bird" is the suggestive title of a $1\frac{1}{2}$ H. P. marine engine recently brought out by Alexander & Crouch, 33 S. Canal street, Chicago. It is guaranteed for two years.

McDonald & Erickson, 42 W. Randolph street, Chicago, Ill., are making use of envelope slips relating to their marine engine, second-hand stationary engines, accessories, etc.

Hall Bros. Gas Engine Works, Philadelphia, Pa., incorporate in their 1905 catalogue of marine gasoline engines a special feature giving detailed dimensions of many parts.

Traction gasoline trucks are covered in a catalogue issued by the Ohio Manufacturing Company, Upper Sandusky, O. Regular sizes are built suitable for 12 to 40 H. P. engines.

Joseph Dixon Crucible Company, Jersey City, N. J., are sending out an attractive booklet, "Pot Leading a Racer," which will be interesting reading to every motor-boat owner.

"Automatic" engines, 5 to 20 H. P., single to four cylinder types, for marine service, are the subject of a two-color catalogue from the Automatic Machine Company, Bridgeport, Conn.

"More Snaps," odd pieces left over from inventory, are listed in a booklet bearing this title, received from J. H. Neustadt Company, St. Louis, Mo. The prices are made especially attractive.

The Continental Motor Manufacturing Company, 242 W. Lake street, Chicago, manufacture a number of types of automobile engines, carbureters, etc., which are described in a series of bulletins, Nos. 11 to 15.

The Field-Brundage Company, Jackson, Mich., have sent out a book of "Facts for prospective purchasers of gasoline engines," in which they have endeavored to compare various types of engines, explaining the advantages of the Field en-

gine in so doing. Accompanying each engine is a book of instructions which gives full information as to how to install and operate the engine.

The New Way Motor Company, of Lansing, Mich., are erecting a factory building, 330x45, for the purpose of increasing their output of air cooled gasoline motors.

Armstrong Bros. Tool Company, Chicago, have recently moved to a new factory building, where they will have improved facilities for the manufacture of their lathe tools.

Fargo Iron Foundry Company, Fargo, N. D., has been incorporated to manufacture gasoline engines and other machinery. Capital stock, \$50,000. Incorporators, T. L. Sykes, H. J. Kellman and F. W. Parsons.

"Designed expressly for the automobile trade" is a prominent phrase on the cover of catalogue No. 15 from Byrne, Kingston & Co., Kokomo, Ind. It relates to Kingston carbureters, coils, plugs, muffles, etc.

The Smith Gas Power Company, Lexington, O., have just issued a catalogue of their automatic suction gas producers, a special feature of which is that they will operate successfully on one charge of fuel per twenty-four hours.

The Chicago gasoline engine, built by the Smith Manufacturing Company, 158 E. Harrison street, Chicago, Ill., is thoroughly described in catalogue No. 16, just received. Illustrations of the engines in actual use add much to the attractiveness of the catalogue.

Colored reproductions of gas engines have come into use quite generally within the last few years. W. P. Callahan & Co., Dayton, O., have recently gotten out a 6x6 four-page folder, the first and last pages showing their engine in colors. The inside pages give descriptive matter.

McCord & Co., 1429 Old Colony Building, Chicago, have recently issued several complete publications relating to their lines. The McKim gasket, to which one booklet is devoted, is a copper-asbestos gasket especially made for gas and gasoline engine. It is made of an elastic material incased in soft rolled metal, so annealed that they make a perfect and last

ing joint. Another booklet relates to the McCanna force feed lubricators by means of which perfect lubrication is assured for every bearing, reducing friction and wear to a minimum. Automobile lubricators are covered in a special catalogue.

The Field-Brundage Company, Jackson, Mich., expects to be located in their new building by the middle of July. The building is a concrete structure, specially designed to meet the requirements of the company. One of their own engines will be used to operate the machinery.

The new catalogue, No. 21 G., of the Capital Gas Engine Company, Maryland and Delaware streets, Indianapolis, Ind., is one of the best printed catalogues received last month. A neat cover design, good illustrations, and well-chosen explanatory reading matter all add to the value of the publication.

"Cross" marine and stationary gas and gasoline engines, built by the M. O. Cross Engine Company, Detroit, Mich., are shown in a loose leaf catalogue. These engines are four-cycle, equipped with jump spark. Single cylinder engines are built in 2 to 8 H. P. units. Multi-cylinder engines are built up to 150 H. P.

A new gas engine company in Chicago is the Bilson-Henriksen Manufacturing Company, of 15 W. Madison street. A folder issued by the company shows vertical engine mounted on skids and especially fitted for farm use. It may also be furnished with the Bilson quick return pump for which special advantages are claimed.

The Vesta Accumulator Company, 1336 Michigan avenue, Chicago, have for seven years been making a specialty of storage batteries, and in a circular of their ignition batteries for gasoline automobiles they list the points of excellence of these batteries. R. E. Hardy Company, 225 W. Broadway, New York, are Eastern agents.

Bulletin No. 1 of the National Battery Company, Buffalo, N. Y., relates to storage batteries for telephone services, particularly the central exchange of the Frontier Telephone Company, of Buffalo. A two-cylinder 10 H. P. gas engine operates a 5½ K. W. generator for charging the storage batteries and also for lighting the building.

THE GAS ENGINE.

STATIONARY—AUTOMOBILE—MARINE.

PUBLISHED MONTHLY BY

The Gas Engine Publishing Co.

Blymyer Building, Cincinnati, Ohio.

ADVERTISING RATES ON APPLICATION. Address All Communications to the Company.

Entered at the Postoffice at Cincinnati, Ohio, as Second Class Matter Feb. 20, 1899.

VOL. VII.

AUGUST, 1905.

No. 8.

Domestic Subscriptions, \$1.00 per Annum.

Single Copies, 10 cents.

Foreign, \$1.50 per Annum.

"If explosions occur in the muffler of the gasoline engine, add more battery," advises a contemporary. It may be a case of weak mixture, when the user will have to add more gasoline.

In another column will be found an abstract of a paper on large Continental gas engines. This is a subject of growing importance to America, and we are sorry that we are unable to present the entire paper. The discussion, in brief, of the various plans which have been finally adopted in regard to regulation, cooling, ignition, etc., show the results of experience of the makers of large engines, and the paper is a most interesting and instructive one.

Some time ago the British Government commissioned a naval officer to investigate the adaptability of motor power for the craft used by Scotch fishermen. The officer made examinations of the style of boats in use and visited British motor manufacturers. He then visited several continental points, investigating engines, paying particular attention to Scandinavian ports, where motor-driven fishing boats were in use. In his report on the matter the officer stated that considerations of safety, reliability, ease of management and control, cost of working and installation and general efficiency were the points which were of most importance. On the score of safety, he criticized the motors using gasoline, alcohol, etc., and considered them useless.

Here is a remarkable decision from a man of rank in the British navy, and who is supposed to have given this subject careful consideration. The fact that neither the English nor the American governments (nor any others of which we know) require licenses for the operators of marine gasoline engines shows that these governments have approved the use of gasoline engines for marine service, as compared with the use of steam engines.

The further fact that there are thousands of these engines in use in boats devoted to all kinds of service, not merely pleasure boats, and that the percentage of accidents due in any way to the engine or the nature of the fuel is very, very small, should be further evidence to the British officer (if, indeed, he really investigated the matter) that gasoline motors are safer than steam engines for marine service.

While there have been cases of accidents in the use of gasoline engines in boats, yet there will always be some accidents, no matter what kind of power is used, or even if sails alone are used. The thing to do is to get the class of boat which gives the best results with the fewest accidents, and we can not conceive how any one who has really investigated the gasoline power boat can "decide that the conditions on board the fishing fleet do not admit of the use of petrol (gasoline) motors."

There has been more or less experimenting among gas engine designers with the injection of water with the explosive charge. An English expert reported recently that water injection was used in three vertical three-cylinder compound engines for about six months, the engines being on full load during the day and about two-thirds load at night. Results showed that while the engines worked better with the injection when clean, after four or five weeks' running they showed signs of pre-ignition with back firing, and, on examination, the walls of the combustion chamber were found incrustated. After cleaning, the engines would run for another period without trouble.

The method of injection was by attaching a regular screw valve to the gas inlet and connecting same to a constant level float cistern. The water spray was thus directly in proportion to the volume of gas and air admitted to the cylinders past the throttle. About one pint of water per H. P. hour was used.

THE REASONING GAS ENGINE OPERATOR.

BY ALBERT STRITMATTER.

"Can you tell me what is the matter with my gasoline engine? She used to run all right, but now I have a good deal of trouble with her. Last month we spent just about twice as much for gasoline as we did before she got to acting up. It is a 12 H. P. engine, and we have had it for about six months. It is in a grain elevator. She starts poorly; sometimes we have to bother a couple of hours to get her to start. Then perhaps she runs all right; that is, she runs, but when we go to put the load on her she stops. Sometimes I imagine I hear a hissing noise around her, but I don't know."

Such was the complaint and explanation of a gas engine user recently. By way of adding to it, he said:

"I've run a number of gas engines before, but I never had this trouble with any of them. I don't understand what can be the trouble."

Like the man whose trouble was considered last month, this operator is evidently inclined to study his engine and try and locate the cause of the trouble. It is not his habit to start the engine and let it run indefinitely without attention of any kind. He also seems to realize that the proper way to locate trouble with an engine is not by *wondering* what the matter is, but by getting at the cause of the trouble and correcting it in a reasonable and logical way.

For the reasoning gas engine operator there are several ways of arriving at the cause of the trouble with an engine. One of these is one known to mathematicians as the "method by elimination," the eliminating from the case under consideration possible causes of trouble which evidently can have nothing to do with the present case.

In this case it is evidently nothing due to defective design or original construction, for the "engine used to run all right." Therefore it is safe to assume that it will run all right again if we can return it to the old condition which existed at the time it did run all right. We may, therefore, with a reasonable degree of accuracy, eliminate difficulties which would be expected in an engine which had never proven its ability to run at any time.

So many troubles arise from defective ig-

niton that we are almost always ready to look over the ignition system in search of some cause for trouble. A defective battery might easily cause this difficulty, except that the engine occasionally runs all right till the load is put on. This, together with the trouble in starting would seem to show that it is something outside of the battery, as battery trouble is more likely to cause failure altogether, or else intermittent trouble. That is, a battery which is just beginning to get too weak for successful results will perhaps furnish sparks for a short time, then die down, then start up again, while a very weak battery will not give any ignitions at all. But if there is something wrong with the insulation, as, for example, a cracked spark plug the engine would possibly start all right and then die down when heated up sufficiently to open up the crack and affect the insulation.

Now, as to the fuel mixture, it is perhaps due to improper feeding of the gasoline. A poor mixture of gasoline and air will often cause a lot of trouble. When the operator attempts to start the engine he will get his priming charge in the cylinder, and after this ignites and gives the starting impulse the engine will take in its first weak charge. This will not ignite, and the momentum of the engine carrying it on over, the engine draws in another charge, which then possibly makes the mixture in the cylinder too rich to ignite. Then the engine stops. Perhaps the operator adds another priming charge, not stopping to reason that there is already some fuel in the cylinder which has been drawn in by the piston suction while the engine was stopping. By this additional priming charge there is no possible chance for the mixture to ignite, so rich in gasoline has it become. The only way by which a start can be made is to open relief and starting cocks and turn the engine over idle two or three revolutions to drive out the accumulation of gasoline and air. Then a fresh start may be taken.

On the other hand, when the priming charge is exploded and the first and second regular charges are drawn in, they may happen to make a mixture which will ignite and thus give an additional impulse.

The weakened charge which is then taken

in may be sufficient to ignite with more or less regularity, but when the load is thrown on the engine will usually slow down and perhaps stop, unless the mixture is only slightly below normal proportions.

Whenever, for any reason, gas or gasoline is taken into the cylinder and is exhausted unignited, there will follow an exhaust pipe explosion when the next succeeding charge is ignited and exhausted. As the operator in the case under consideration says nothing of this, we may assume that the trouble is probably not with a weak mixture.

The mention of a "hissing" sound gives a possible clue. Perhaps the compression is leaking, as this is usually accompanied by a hissing or whistling sound. Many times the location of the noise can not be discovered, as it begins very gradually, and as there is no serious result evident, the operator often forgets about or thinks nothing of it, until some time he realizes that the engine is evidently not giving all the power that it should and is also using considerably more fuel than it once did.

This condition is the losing of compression, usually around the piston. Very many gas engine users do not realize the importance of having a good compression. But when we learn that compression of the mixture is one of the fundamental principles of every successful internal combustion engine, we begin to realize that it means something.

Until compression in a gas engine was accomplished there could be no gas engine in a commercial way, for the economy and efficiency of non-compressing engines has never been such as to permit of their general use, and none have been built for many years.

Compression adds to the power secured from each charge exploded. The higher the compression can be carried successfully the more power resulting from each charge and from the engine. The more power we get from each charge the less will our fuel bill be.

Compression is secured by the use of compression rings, which fit into grooves in the piston, and by their springing out against the cylinder form a tight joint. Of course, it is essential that the valves, valve cages, igniter plate, etc., should all be gas-tight on the compression and expansion strokes.

If for any reason the rings fail to spring out there will be a leak of compression. Too

much lubricating oil or too much fuel, which thereby causes a deposit of carbon, will result in the rings gumming in the grooves and allowing leak of compression. Wearing of the rings or of the cylinder will also result in leaks. If any of the cylinder head fittings, as the valves, etc., are not tight, leaks will occur.

Now, a leak of the compression is really worse than a very low compression, for a low compression engine will still hold the explosive pressure after ignition. But an engine with a leak will not only leak the compression, but also the explosive pressure.

Of course, the result of this is that the full benefit is not derived from any of the charges, and, therefore the engine loses power, and at the same time increases its consumption of fuel.

When the loss of compression reaches a certain point it will be very difficult to make it start, and even after it starts the throwing on of the load will often cause it to stop.

This was what proved to be the cause of the trouble in the case referred to at the beginning of this article. Of course, a leak around the valves, igniter plate, etc., may usually be overcome by regrinding the seats or putting in new packing. Leaks past the cylinder may be remedied by cleaning the cylinder and piston, and especially the piston rings and grooves, with gasoline or kerosene, so as to permit the rings to act freely. If the rings are worn too much new ones will remedy the trouble. Or, if the cylinder is considerably worn, it will be necessary to rebore it and fit a new piston. An interesting claim made in the catalogue of one gas engine manufacturer is that their cylinder walls are made thick enough to permit of reboring four times, if necessary, so that the life of these engines should be very long.

In discussing suction gas producers recently, Mr. Dugald Clerk is reported as having said that up to certain powers it was proving a very dangerous competitor of coal gas. Being able to start even a 40 H. P. engine within a very few minutes, and not needing to give the producer much attention, there was considerable advantage. In one test he had made he found that the engine was receiving 86 to 89 per cent of all the heat contained in the coal.

**THE GROWTH OF LARGE GAS ENGINES ON
THE CONTINENT.**

At the June meeting of the Institution of Mechanical Engineers, held at Liege, Belgium, Mr. R. E. Mathot read a paper on the growth of large gas engines on the Continent, and the following is an abstract of the paper :

The development of large gas engines can be said not to date back further than five to six years. Eight to ten years ago they were initiated simultaneously in Germany, England and Belgium, early attempts being made to utilize blast furnace gas, which was expected to open up such a vast field for the employment of large engines. Although the first trials were only attempted on small engines, the results of the experiments soon gave encouragement to the efforts of the investigators. The Cockerill Company, of Belgium, constructed a single-acting Otto cycle engine of 200 H. P., which has been working regularly at their establishment for six years. This stage in the path of progress was strongly accentuated by the 600 H. P. engine on the Deiamarre-Deboutteville system, which the Cockerill Company exhibited at the Universal Exhibition at Paris in 1900. This magnificent engine was single-acting, the pistons at each explosion. In a short time seven inches and a stroke of 4 feet $7\frac{1}{8}$ inches. It was designed to develop its power at 80 r.p.m., which, with an initial explosive pressure of 310 to 325 pounds per square inch, produced on the piston a pressure of 300 tons at each explosion. In a short time several famous firms entered, in their turn, upon the construction of large engines intended to utilize the gases liberated by the various reactions occurring in the manufacture of iron, coke, etc., and the metallurgical industry was not long in entering upon the path of progress by replacing for its old boilers and engines powerful installations of explosion engines. It remained, however, to conquer the vast domain of manufacturing industry. It is in this sphere that the struggle is taking place with the steam engine, which a long career has endowed with improvements in methods and execution. The physical laws which govern the production and utilization of steam as a motive power have long been known, having at an early date emerged from the ob-

scurity which enveloped their interpretation, and thermodynamic science has given them definite sanction by numerous investigations.

Improvements in construction advanced side by side with the progress of scientific theory to accomplish mechanical marvels. Steam is, however, a fluid much less complex in nature than explosive mixtures. The action of steam is governed by precise laws which pertain only to the sphere of physics, whilst the production of combustible gases and their mode of evolution under the form of explosive mixtures in engines, are as much within the domain of chemistry as of physics and mechanics. Although the generic theory of gas engines has rested up to the present on a series of hypotheses which have not yet received experimental confirmation, these engines have gained ground in application to various industries with exceptional rapidity, compared with any other kind of motive power. The invention of gas producers and the improvements made in the last few years, and especially in those working with the direct suction of the engines, are manifestly most important factors in this success.

Before examining the successive developments of these producers, the principal phases of the improvements through which the engines themselves have passed will be analyzed. It was, first of all, in Germany, and then in England, that their construction underwent the most rapid development. Afterwards America was the country which produced the greatest number. It is, therefore, not surprising to notice that each type has retained in its construction or design something which, as a birth-mark, reveals its nationality. The German engine has always presented the appearance of a well-finished machine as regards constructional details—all the parts of the machine were usually polished bright, which disclosed a real anxiety on the part of the makers to impart a high finish to their machines. This, of course, affected the price, but the life of the engine was materially increased thereby. There are cited as examples of longevity certain "rack" engines of the Otto-Langen type and make, which are completing a career of thirty years' service.

The English makers took up another position, namely, that of producing cheaply in order to produce on a large scale. Thus we are indebted to them to a great extent for the propagation of small engines for industrial purposes. This was a fertile field for investigation and experiment, which our makers, deeply immersed in the construction of powerful engines, have often failed sufficiently to notice. English engines, designed for the use of town gas, vie with each other in ingenuity in the arrangement of their parts, in order to attain efficient and simple mechanical devices. The lift of the valves and their mode of operation are in general obtained by cam and lever movements, with a definite movement giving a positive action. The governor itself is reduced to its most simple expression, since in the "hit-and-miss" arrangement its action consists merely in displacing to a slight extent a small piece which is normally interposed at the point of contact between the controlling lever and the stem or spindle of the gas valve, in order to open it or to leave it closed, and which transmits the motion by which the valve is opened; when the piece is displaced the motion is no longer transmitted. Unfortunately, this type of governing is not compatible with the requirements of the working conditions of modern large engines.

The merit of having entered upon the new path which the construction of gas engines has followed for five or six years undoubtedly belongs to the Germans. The old makers of gas engines in Germany took the initiative of departing from old methods. In a short time their processes were themselves improved and perfected by the makers of steam engines, long accustomed to circumvent or overcome practical difficulties in the construction of large engines. Without large gas engines tending towards a single type it may be said that they all have manifest tendencies to resemble the modern steam engine from the point of view of their form and valve gear. Having regard to the fact that valves are the common means of distribution, that they are operated by a side shaft, and that large engines now work double acting, it was natural and logical that the explosion machine should borrow from the steam engine the design and methods with which it has been equipped in its long and victorious career. The introduction and growth of suction gas

producers and the utilization of blast furnace gas; coke oven gas, etc., which have marked the development of large gas engines, have led to the creation of different designs for their construction. Different principles have thus been modified in their applications, such as the regulation, the compression, the cooling, the ignition. Without dwelling upon the different stages of their transformation, it will be shown in what way modern methods differ from old methods, and the probable direction of future change.

For the reasons which have been enumerated, the "hit-and-miss" system of regulation has been completely abandoned. This system, moreover, does not lend itself to working with very light charges, or with no charge, in the case of engines fed by suction gas producers. As in these circumstances, the gas supply alternates with three, four or even five strokes with no charge, it happens that the suction which determines the supply of air to the producer is not sufficiently uniform, and that the fire finishes by being extinguished; or, to say the least, by producing a very poor gas through the lack of activity in the furnace. German makers then invented the conical cam for the admission of the gas, which, being displaced by the action of the governor, produced variable lift of the gas valve. But this device was only a variation of the stepped cam or of the stepped pecker block, which the English makers had tried in their electric types, and they soon discovered the uneconomical results it caused. The stepped arrangement had the advantage over the conical cam of lessening the work upon the governor. But, as both systems acted on the quantity of gas admitted, whilst the quantity of air of the mixture remained constant, mixtures of variable composition—often too rich in the case of a full charge, and always too poor with the weak charge—were formed. In the latter cases the ignitions were tardy, the diagrams bad and the efficiency less as the charge was reduced in richness. Whilst with a good engine regulated by the "hit-and-miss" system the consumption at half load, which from the industrial point of view is the most interesting, was not more than about 20 per cent. higher per H. P.-hour than with full load, it became 40 to 50 per cent. higher with an engine with variable mixture.

It is, therefore, towards the system of

admission of a variable quantity of mixture, but of uniform composition, that makers have directed their path. A few English makers, Tangye, Willans and Robbins, also Westinghouse, decided the question by throttling, by means of a butterfly-valve or a cylindrical slide-valve, the mixture regulated in advance; this butterfly-valve or slide-valve being controlled by the governor and placed immediately before the valve admitting the mixture to the cylinder. The principle was still further improved by an automatic mixing valve, preceding this regulating device, as constructed by Benz in his four-cycle engines. However, the majority of the Continental makers, with the object of obtaining a prompt and more reliable action of the governor, have endeavored to combine under one single control and in a single device the slide or inlet valve and the mixing valve, and, instead of throttling the charge in the passage, they have provided the mixing valve with a variable stroke under the action of the governor. The application of this device has not, however, been extended to very large engines, as it was found to be too heavy and cumbersome to handle and dismantle for the purposes of cleaning. Admission in variable quantity of a uniform mixture involves variable compression and the necessity of a high *original* compression. If for the full admission of the charge this compression was from 170 to 200 pounds per square inch, it might fall to less than 45 to 55 pounds per square inch for the minimum admissions, which would interfere with the prompt ignition of the very poor mixtures which are at the present time used in engines applied for industrial purposes. Further, this mode of admission produces at the time of the suction with light charges, a vacuum or negative work which would become considerable in engines of high power. This has been avoided by combining with the variable admission of the constant mixture an additional admission of air or impoverished mixture, in order to effect at the same time the constant compression and minimum vacuum in the cylinder. The firms of Cockerill and Nurnberger Maschinenbau have already adopted mechanism for this purpose.

The lift of the valves, which is usually effected in the old engines by simple movements of levers at one end of which a cam acts upon a roller, has also undergone some alterations.

In large engines this has been replaced by eccentrics and "roller-path" levers, thus imitating what is applied to steam-engines of the Sulzer type. Some special valve gears have even been provided with ratchet movements with air-pistons.

The main object of these improvements has been to secure a more gentle and silent action relative to the size and weight of the parts to be actuated.

It is advisable to bear in mind with regard to English and American engines that the compression generally adopted for large gas engines is from 170 to 200 pounds per square inch.

Cooling is one of the points which has most attracted the attention of makers of large gas-engines, as the effects of tension in the castings, due to unequal expansion, play a considerable part in the heavy pieces which enter into their construction. Cylinder heads of explosion chambers have been, in fact, one of the principal sources of difficulties and disappointment, as without any apparent reason they fracture at the most unexpected places. It is only long experience, assisted by numerous examples which has placed makers on the track of the most appropriate forms for securing the strength of cylinder heads, rather than the selection of the materials to be employed in their construction. Steel itself has been tried without success. The principal factor for the preservation of cylinder heads is the manner in which the cooling water circulates therein, and the type which appears to be favored at the present time for four-cycle engines is the one which places the inlet and exhaust valves in the same vertical axis. Both are placed in a passage or ante-chamber surrounded on all sides by the cooling water. In order to secure for the whole of the parts an equal expansion this chamber is arranged symmetrically relative to the axis of the cylinder. The exhaust is allowed to discharge on the extension and is surrounded as completely as possible by water. An abundant circulation is thus provided around the seat and the stem of the exhaust valve, which is also provided with an internal circulation in the case of engines of more than 60 to 100 H. P. The water which has entered at the bottom of the cylinder head escapes at the top, or if need be in the case of engines of less than 75 H. P. completes its circulation in the jacket of the cylinder proper. In some instances the jacket is cast

with the frame, and the cylinder itself is independent, and free to expand, whilst the cylinder head is attached by flanges and bolts. This arrangement is the only one which secures a large base for the engine, and avoids the overhanging cylinder, which is completely banished from modern construction.

In order to combat the excessive temperature which attends high compression, certain makers have even provided the piston ends of their single-acting engines with a water circulation. This is effected by a pump forming part of the engine. This is evidently a complication which others have easily avoided for engines even of 150 H. P. by arranging the piston so that a free access of air, due to the to and fro movement, alone effects the cooling. In order to derive every economical advantage from high compression without running the risk of self-ignition, the firm of Koerting has even arranged inside the explosion chamber of their Otto cycle engines a hollow casting through which there is a special water circulation. This cooling effected in the very heart of the mixture deals with the excessive temperature there, and is said to have given the best economical results. In double-acting engines the cooling is still the object of great attention, and apart from the cylindrical jacket and cylinder ends, independent water circulation is used to cool the piston and piston rods, the seats of the exhaust valves, and the stuffing-boxes. The general temperature of the surrounding parts is kept cooler than in English engines, and for this purpose water is delivered at certain parts, such as the piston and piston-rods, at pressures from 15 to 60 pounds by means of a special pump.

It appears from several experiments which the author has made on double-acting Otto cycle engines that the quantity of circulation water required for the different parts is as shown in the accompanying table.

Cooling water required per B. H. P. hour for engines of 200 to 1,000 H. P.	Gallons.
Cylinders, cylinder heads and stuffing boxes	4 to 5½
Pistons, piston rods	1½ to 2½
Valve boxes and seats and exhaust valves	¾ to 1½
Total	6½ to 9½

These figures imply water admitted on an average of 53.6 deg.—59 deg. F., and leaving the cylinder jackets at 77 deg.—95 deg. F., the pistons at 95 deg.—104 deg. F.,

and the valve seats and boxes at 113 deg. F. An engine of 1,000 H. P., of the two-cylinder double-acting type, would, therefore, require about 8,900 gallons of cooling water per hour. As this is an excessive quantity which is not available at every works, recourse is commonly had to the use of cooling towers which reduce the consumption of water to about 1-9 gallon per H. P. hour, absorbed by evaporation. This method has also the appreciable advantage over the ordinary water circulation of eliminating, owing to the continuous use of the same water, the deposit of calcareous incrustations. Without possessing in the case of gas engines the same dangers as in steam boilers, lime scale and deposits still constitute a drawback. They obstruct the pipes and passages, and impede the regular cooling by coating (with a non-conducting material) the metal at the places where a high temperature is most injurious. At the parts cast with a double jacket, and which can not be dismantled, it is necessary to arrange large openings covered by bolted lids in order to enable free access to the inside to remove these deposits.

The question of ignition has been solved in a satisfactory manner by the use of magnetos producing a spark on the break of the circuit which in a short time has ousted all the old methods of ignition, such as the incandescent tube, the spark produced by batteries and accumulators, by dynamos, etc. This modern magneto ignition has for three years been provided with a timing gear, by means of which the ignition can be advanced or retarded experimentally during work. Still, as all working parts subject to the frequent and abrupt movements of the current breaker of the magneto are liable to get out of order and to wear rapidly, it is necessary to meet these objections by the adoption of very light parts with but little inertia. They must be easy of access and to handle for upkeep and inspection. With the increase in dimensions of engines it has been necessary to deal with greater volumes of explosive mixtures but of poorer composition. This has wisely led many makers to provide their double-acting engines with two distinct ignitions for each piston face, the one placed near the inlet-valve at the top and the other at the bottom near the exhaust-valve.

Lubrication has also of late formed the subject of important improvements. In en-

gines of medium power, *i.e.* up to 150 to 200 H. P., the main bearings of the crankshaft are usually lubricated by means of a revolving ring plunging in an oil bath. For larger engines bearings with brasses consisting of several parts, to take up the wear and the working stresses, are used. As this system renders it impossible to apply the lubricating ring which gives such good results in dynamos, recourse has been had to continuous oil-feed under pressure. This pressure also secures a more reliable lubrication of large surfaces supporting great loads, as is the case with the crankshafts of engines of 1,500 to 3,000 H. P. which exceed 1 foot 8 inches diameter. For lubrication the pistons and the stuffing boxes of the piston-rods, oil feed under pressure is a necessity, as the oil is more reliably conveyed to the rings, the tightness of which depends to a great extent on the free play secured to them by proper lubrication. Excess of oil in the cylinders which, by rendering them dirty, is the principal cause of "back firing;" this has also been greatly reduced by the use of a draining device.

The mode of regulation by admission on each cycle enables flywheels relatively less heavy to be used. The same may be said of the application of double-acting, and of multiple cylinders. The requirements, however, which are now expected from engines in large electric light stations have given rise to the use of special flywheels, with the ob-

ject of reducing as much as possible the degree of cyclic irregularity.

Modern large engines have attained high organic efficiency owing to the proportional reduction of their weight and the finish of their construction. Double-acting engines are usually made with a weight of at least 220 pounds per H. P. It is admitted that Otto cycle double-acting engines attain 90 to 92 per cent. mechanical efficiency, whereas an output of only 75 to 80 per cent. was attained by two-cycle engines. This waste, being due to the work absorbed by the air-pump and by the gas pump, can not, however, deteriorate the value of the magnificent engines, of which the Oechelhauser and the Koerting are classical types possessing their own advantages. Double-acting Otto cycle engines attain a thermal efficiency of 28 to 30 per cent. relatively to the effective work, *i.e.*, the H. P. hour is attained with about 8,729 B. T. U. This consumption converted into the volume of the different gases used industrially would be as follows:

Coke-oven gas 20.7 cubic feet.

Mond producer-gas 62.2 cubic feet.

Anthracite producer-gas 65.4 cubic feet.

Blast-furnace gas 88.3 cubic feet.

This implies mean chemical compositions and the average calorific values.

The author then takes up and considers very thoroughly the development and improvement of numerous large continental makes of engines.

SOUNDING FOR BRIDGE AND DAM FOUNDATIONS.

In preparing to build bridges over rivers, dams, etc., it is usually desirable to know as much as possible about the geological foundation of the earth's surface. The Preslar-Crawley Company, Cincinnati, O., makes special test boring machines for making subaqueous and subterranean examinations for locks, dams, bridge masonry, etc. By means of these the character and thickness of every foot of loose or rock formations is determined.

To show the nature of some of this work, some two years ago a mile and a half of the river bed of the Ohio River was examined near Parkersburg, W. Va., for the United States Government. About sixty-five holes were drilled. In a similar examination near Little Hocking, O., two miles

of the river bed were examined and about sixty holes were drilled. These were undertaken to determine the location of movable locks and dams. From each of the holes drilled there were taken out preserved rock cores showing the accurate formation of the earth. The United States Assistant Engineer stated that the information secured was invaluable in designing and estimating the cost of the two locks and dams.

The photograph on opposite page shows two complete foundation sounding outfits in operation. Gasoline engines are used to operate the drills. Portable outfits, similar in design, are used for land operations. The Preslar-Crawley Company makes a special light-weight multi-cylinder gasoline engine, which, however, is not the type shown

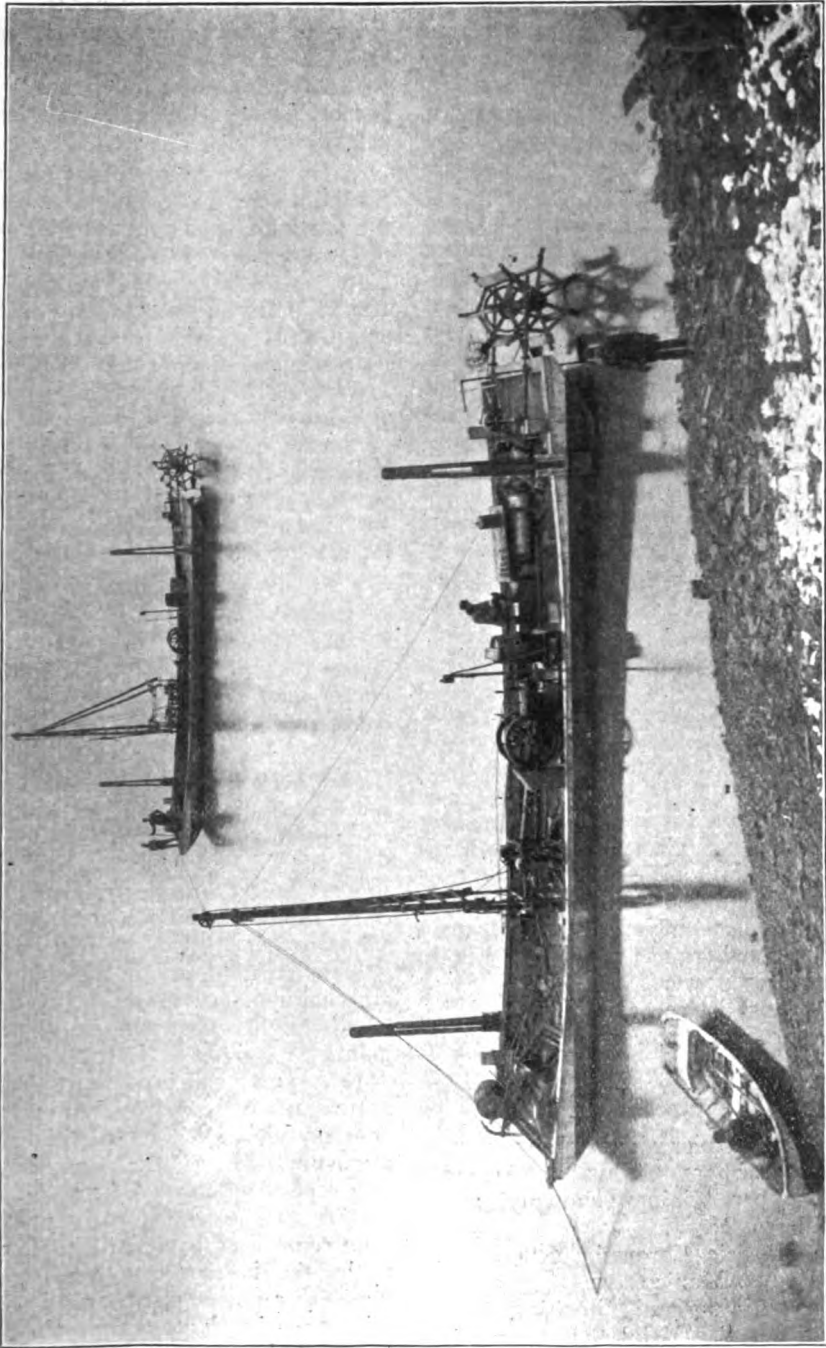

PRESLAR-CRAWLEY FOUNDATION-SOUNDING OUTFIT

GAS PRODUCER POWER PLANTS.*

BY SAMUEL S. WYER.

The fact that gas producer power plants have received so little attention in America may be attributed to five conditions: (1) Ignorance and prejudice, (2) newness of work, (3) inadaptability of gas engines, (4) fuel economy not imperative, (5) smoke nuisance not given attention.

1. The only literature pertaining to gas producer power plants is that found in the various technical journals and in the transactions of engineering and other technical societies. In many cases the papers are of a fragmentary character, and seldom are they complete or comprehensive. It may be that the lack of reliable data available to engineers is the cause of the ignorance and prejudice that exists.

2. The manufacture of producer gas is an old process, and gas engines have been developed to a very high stage of mechanical efficiency, hence there is no valid reason why such installations should be regarded as experimental.

The Winchester Repeating Arms Company, at its plant in New Haven, Conn., has a Loomis-Pettibone gas producer plant, built primarily to furnish gas for fuel purposes (such as for annealing ovens, furnaces, etc.); a 100 H. P. Westinghouse gas engine was installed some time ago, and later three direct-connected units, each of 175 H. P., have been ordered. At the present time this example is one of the best instances in America of an industrial producer gas plant where gas is furnished both for fuel and for power.

The following list comprises some of the larger gas producer power plants now in operation in America:

Moctezuma Copper Company, Nacozari, Sonora, Mexico.

Guggenheim Exploration Company, 700 H. P., Santa Barbara, Chihuahua, Mexico.

Detroit Copper Mining Company, 1,000 H. P., Hillburn, N. Y.

Potosina Electric Company, 600 H. P., San Luis Potosi, Mexico.

Velardena Mining and Smelting Company, 2,000 H. P., Velardena, Durango, Mexico.

*Paper read before American Institute of Mining Engineers.

Sayles Bleacheries, 250 H. P., Saylesville, R. I.

It is obvious that much has already been accomplished in this important field of power generation.

3. No gas producer plant can be successful unless the gas engine is adapted to suit the particular gas available for its use. On the authority of Westinghouse, Church, Kerr & Co., an engine which will develop 100 H. P. with natural gas will give only about 80 H. P. with producer gas—a loss of 20 per cent. With a 200 H. P. engine this loss would be about 15 per cent, and with sizes above 300 H. P. it would be about 10 per cent. Hence the obvious necessity of designing the engine to suit for the particular fuel it is to use. Several failures have been made by neglecting this important point.

4. In the list of plants given above it will be noticed that most of them are in remote regions, where the cost of fuel is high; hence the high economy of the gas producer plant was necessarily a feature that commended itself.

5. The laxity of the laws regarding the smoke nuisance has not made it imperative for manufacturers to give attention to the prevention of smoke. As soon as regulations concerning the smoke nuisance are enforced the gas producer industry will receive a new impetus on account of the easy solution that the gas producer plant offers.

Data relative to the design, operation and maintenance of gas producer plants, mostly highly favorable to the use of such plants, are given as follows:

1. A good gas producer, from the very nature of its construction and operation, does not allow the smoke to escape into the atmosphere, hence the gas producer itself presents a practical solution for the elimination of the smoke nuisance. The non-requirement of a chimney means a large saving in the first cost and in the maintenance of a power plant, and is an additional advantage in plants where the æsthetic features of the design are of importance; for instance, in the case of a municipal power plant.

2. The cost of labor required to operate

a gas producer plant is about the same as that required in a steam plant of similar size. However, during the time that a gas producer plant is idle it requires less attention than does a steam boiler. In the case of a municipal pumping station, the labor required to operate the producer plant would be one-half that of a similar steam plant; the gas plant being operated as follows: The gas producers to use coal for supplying the gas to operate a three-cylinder vertical gas engine direct connected to a triplex double-acting power pump. In this case the usual fire engine would be dispensed with, and, should a fire occur, the requisite pressure obtained by pumping directly into system. For ordinary domestic supply the pump will deliver the water into a water tower, from which the mains receive the supply as needed. In every case the maximum quantity of water required during a fire is much larger than the average domestic consumption; hence the pump must be designed for this maximum quantity. As a result, the working of the pump at its full capacity for six out of twenty-four hours would furnish enough water for the daily consumption; the pump would usually be operated from 7 to 10 a.m. and from 3 to 6 p.m.

A gas holder of sufficient capacity to run the pump for thirty minutes is to be filled before the producers are closed down. Compressed air is to be used to start the engine, which may be put into motion by simply moving a lever. The engineer is to live adjacent to the plant, so that when an alarm is sent in to the hose company and simultaneously to the engineer's home and to the plant, it would be possible for the engineer to have the pump at work direct into the system by the time the fire company could reach the fire and make hose connections.

Since the gas holder would supply the engine until the producers could be started, the above scheme of operation eliminates the necessity of a night fireman and the keeping up of at least 70 pounds of steam pressure in a steam plant. A similar arrangement could be equally well adapted for fire purposes in connection with large industrial plants. With regard to the skill required, a producer gas plant does not require any greater skilled labor than does a steam plant of similar size; however, in some cases it may require time for men

trained to handle steam apparatus to become accustomed to gas engines and gas producers.

3. Two well-known engineering concerns give the following data regarding cost of installation:

The cost of gas power plants, including gas generating plant and gas engines, up to 500 H. P., is about 25 per cent higher than the cost of a steam plant of similar size. Large plants, from 1,000 H. P. upward, cost about the same as a first-class steam plant of similar size.

4. The cost of repairs on a gas producer plant will not exceed that of a boiler plant.

5. In order that a gas producer plant shall be commercially successful, it must be able to make, from a low-priced fuel, gas that is sufficiently clean for use in an engine. Bituminous slack is usually the lowest priced fuel to be had; however, anthracite culm, or even wood, may be cheaper in some localities. In all cases the percentage of sulphur must be low, if the gas is to be used in a gas engine. Frequently the use of a mechanically washed coal will be economical.

6. The only reliable way to remove tar and other hydro-carbons from gas made from soft coal is to have the producer so arranged that the gas comes in close contact with an incandescent mass of carbon. No mechanical means has yet been found to be successful, although several forms of centrifugal apparatus have been tried. For the removal of fine dust particles, however, centrifugal fans have proved very satisfactory.

7. The stand-by loss of heat is very small, being limited to radiation only; a gas producer is closed during the time it is not making gas, and the entrance of air is thereby prevented. This feature is a marked advantage over a steam boiler under similar conditions.

8. Even after a producer has been idle for several hours it may be started, and can be working at its full capacity within fifteen minutes. A gas holder is generally used in connection with the producer, from which a supply of gas can be taken to start the gas engine instantly and keep it in operation until the gas producers are making gas.

9. A gas producer may be stopped instantly by simply shutting off the supply of air and steam.

10. The gas from the gas producer is

quite uniform in composition, and, as it usually passes first to a holder before reaching the gas engine, it becomes thoroughly diffused, thus insuring a still greater uniformity.

11. The thermal efficiency of gas producers is generally about 80 per cent, and in some cases it is even higher than this value.

12. It is much easier to use an automatic feeding device on a gas producer than on a steam boiler, because all producers are placed vertically, and the fuel can be dropped into position by gravity. The use of an automatic feed always decreases labor and insures more uniformity in the composition of the gas produced.

13. The rate of gasification in a gas producer is relative to the character of the coal used. The best rate determined by experience is 12 pounds of coal per square foot of grate area per hour, although some makers have advised as high as 20 pounds of coal. Experience has also demonstrated that too rapid driving means a wide door for the admission of adverse gasifying conditions.

14. The amount and frequency of poking a gas producer will depend on the nature of the fuel and the design of the producer. The mechanical agitation of the fuel bed (as in the Kitson and Fraser and Talbot producers) eliminates poking entirely. In using bituminous coals the difficulties of clinker formations is augmented by the production of coke. The judicious use of a steam blast and automatic feeding will generally reduce poking to a minimum, and, in some cases, will eliminate it entirely. Hand poking is very laborious for the attendant, and usually it will be shirked whenever possible. Gas will usually escape around the poke holes while the producer is being poked, which will vitiate the air in the producer room and also affect the regularity of the composition of the gas.

15. The calorific value of producer gas varies from 125 to 150 B. T. U. per cubic foot.

16. The generation of 1 B. H. P. per hour with from 1 to 1.25 pounds of coal or 3 pounds of wood is very common producer gas power plant practice at the present time, and the gas contains at least 80 per cent of the heat energy resident in the fuel.

17. A very important advantage of the producer gas installation is that the gas does

not condense or lose power on its way to the gas engine. On the contrary, the cooler the gas the better it is for the engine. With steam the condensation is considerable.

18. It is easy to prevent leakage of gas from the piping, owing to the low pressure of the gas (about 2 inches of water); whereas, with steam, there is often much loss and inconvenience on this account.

19. By using isolated engines a large saving in shafting may be made in many cases. It is not possible to do this in steam plants and still maintain a good economy.

20. The floor space required for gas holders, gas producers and auxiliary apparatus is about the same as that required in a steam plant; the holder, however, need not be placed adjacent to the producers, but at any other convenient place.

21. A gas producer plant is under much better control than the average steam plant, because in the gas producers the air supply rate of gasification as well as the fuel supply can be regulated more easily.

22. One of the most potent advantages of the gas producer plant, compared with the steam plant, is the ability of the former to store the heat energy in a holder where it may be drawn upon for immediate use. In this way irregularities and fluctuations of load need not affect the regularity of the action of the gas producer. This condition means an economy of operation and convenience of use that are impossible with any steam plant.

23. Another important advantage of the gas producer power plant is that, in many cases, the gas may be used both for power and for metallurgical purposes, the same pipes being used to supply engines and furnaces. The plant of the Winchester Repeating Arms Company, at New Haven, Conn., illustrates an installation of this character.

24. In many cases it is a serious matter to secure a sufficient supply of water for a steam plant, and sometimes, even with an adequate supply, the quality of the water is such that it is entirely unfit for use in a steam boiler. One of the most annoying difficulties of many steam plants is the trouble caused by the corrosion and subsequent cleansing of the boilers, together with the maintenance of feed water purifiers.

The gas producer power plant forms an almost ideal solution for the problem of water supply. With a producer in normal

condition, the consumption of water will not exceed 2 pounds per B. H. P. hour. The water used in cooling the gases in the scrubber may be cooled in a simple tower and used repeatedly.

25. There is no difficulty in piping gas for several thousand feet in order to reach an engine that drives an isolated machine; this often makes it possible to dispense with abnormal lengths of line shafting and the consequent friction loss or other unsatisfactory methods of power transmission. This condition is especially valuable in places where electrical power is not used.

26. Standard gas producers now range from a few H. P. to more than 500 H. P. in size.

27. There is less danger of explosion in a gas producer plant than there is in connection with a steam plant; moreover, should an explosion occur, it would be much less violent and destructive than that of a steam boiler.

28. If desired, the gas producer plant may be placed near the fuel supply, which in many cases would reduce the expense of transportation, the gas being piped to the gas engines of furnaces where it is to be used. This arrangement, which is impossible with a steam plant, means a decided saving in favor of the gas producer installation.

29. The preceding paragraphs show the many strong advantages of the gas producer as a power generator; the large number now in successful operation shows that the experimental stage has been passed and that they have become a formidable competitor of the steam boiler. The time is not far distant when gas producer locomotives for railroad service, gas producer portable engines and gas producer power plants for marine service will be in common use.

The advantages of the gas producer for each of the above three classes are:

I. GAS PRODUCER LOCOMOTIVES, being—

1. *Smokeless.*—*a*, Trains and stations may be kept cleaner; *b*, tunnels may be passed through with greater safety; *c*, comfort of passengers will be increased.

2. *Cinderless.*—*a*, Fuel loss will be decreased; *b*, comfort of passengers will be increased; *c*, large fire losses due to sparks will be eliminated entirely; *d*, insurance rates on property adjacent to railroads will be less.

3. *More Economical.*—*a*, In fuel, since the amount used would be less than one-half that used on steam locomotives; *b*, in water, since the amount used would be less than one-eighth that used on steam locomotives; *c*, in time, since the time required to take fuel and water would be less; *d*, in labor in firing on account of automatic feed and decreased amount of fuel used; *e*, in idleness, since stand-by losses would be very low; *f*, in number of fuel and water stations required.

4. *Safer*, since the danger of boiler explosions is eliminated.

II. GAS PRODUCER PORTABLE ENGINES, being—

1. *Smokeless.*—*a*, Large fire losses due to sparks will be eliminated entirely; *b*, insurance rates on property adjacent to where an engine is used would be less.

2. *More Economical* in *a*, water; *b*, fuel; *c*, labor; *d*, time required to secure fuel and water.

3. *Safer*, the danger of explosion being eliminated.

III. GAS PRODUCER POWER PLANTS FOR MARINE SERVICE, being—

1. *Smokeless.*—*a*, Ships may be kept cleaner; *b*, passengers will have more comfort; *c*, a battle ship could conceal its location more easily.

2. *More Economical* in *a*, fuel; *b*, water; *c*, time required to fuel; *d*, bunker capacity; *e*, floor space; *f*, apparatus required, since all of the condensing machinery would be dispensed with.

A. L. A. M. MECHANICS' MEETING.

On July 7 twenty-three of the mechanical engineers of the A. L. A. M. continued the discussion of carbureters. Those whose cars are fitted with a special carbureter brought one with them, and the working and construction of each was explained. Before this there was a discussion as to

whether an exchange of ideas might not lead to a unity of pattern, but the general opinion seemed to be that it would not, but that fundamental principles might be developed to the advantage of all.

The subject of the August meeting is to be "Clutches and Bearings."

SOME GAS ENGINE ACCIDENTS.

BY A. A. ANDREWS.

So long as a piece of machinery is made, and so long as it may be abused or put to other than legitimate service, and so long as material is imperfect in any way there will be accidents. Revolving parts will occasionally break, fingers and clothes will be caught in gears, etc.; belts will fly off, and so on. Steam boilers and engines, flour mill machinery, saw mill machinery, electrical machinery, street and railroad cars all have their peculiar causes of accidents, and the wonder is that there are not more of them. And, as the gas engine is not by any means perfect, either in construction or material used, there will be some accidents with gas engines. I have been interested in following up the reports of gas engine accidents of various sorts, and have kept track of some of them, as well as complaints which were published in daily newspapers regarding the type of engines.

In the issue of THE GAS ENGINE for November, 1903, there appeared an article on "Gas Engine Accidents and Break-downs," in which the accompanying table was given relative to accidents which had occurred in England during 1902:

	Steam Engines. Per cent.	Gas and Oil Engines. Per cent.
Accidents or causes unascertained	30	34
Negligence of owner or operator	23	35
Old defects or wear and tear	24	19
Faulty design or bad workmanship	23	12

As was stated in that article, this table would seem to show that "the English gas engine is safer than the English steam engine in matters of design, workmanship and durability, but that the operator of the gas engine runs more risk of accident from his own carelessness than does the steam engineer."

A gas engine was installed in the basement of a building, and in this basement there were employed a number of young women and young men. Suddenly, without notice, one afternoon several of the young women tumbled over unconscious and presented the appearance of having been asphyxiated. The cause of the trouble was found to be a gas leak back of the gas meter, and the gas company's expert had exam-

ined and approved the erection of the pipe prior to using the engine. But, as a gas engine was used, the report was spread that the engine was responsible for the trouble. The young women all recovered in a few hours.

The following is a clipping from an Ohio newspaper of some months ago:

"The C. H. & D. Railway Company has a gas engine south of the passenger station, which is used to elevate coal and drop it into the tenders of engines. The engine is very noisy, and at times the explosion is so compressed that a loud report like that of a gun is the result. The report of the engine escape pipe aroused the neighbors, and the police were asked to investigate the shooting in the vicinity of the railroad, and learned the cause."

The trouble was no doubt due to muffler explosions, caused by defective ignition or by too weak fuel mixture; but the reporter evidently got a little mixed when he wrote, "The explosion is so compressed."

In another Ohio paper a gas engine was reported as having "exploded" (which, of course, it did every time it took an impulse), but just what sort of an accident resulted I never learned.

In Indianapolis there was a fire in an automobile garage, and when it was over "it was found that the diaphragm of one of the large gasoline engines had bursted in the basement and that the gas had taken fire." What do you suppose was the cause of the fire, and what happened to the gas engine?

A Michigan daily gave the following report of trouble caused by gas engine exhaust not being properly cared for:

"Friday evening E. E. W— and John P— were nearly asphyxiated by gas from the exhaust of a gasoline engine in the former's machine shop in this village. The exhaust from the engine ran under the building. W— boarded up the outside for winter, not thinking that he thus shut off all escape for the gas which oozed up through the floor. P— was first overcome, falling to the floor in a faint. W—, in an effort to get him out of the building, was overcome just as he dragged the unconscious man across the threshold. Medical assistance was promptly summoned and the

two boys were soon over all effects of the gas. Hereafter that exhaust will have plenty of vent."

Indiana is a State where many gas engines have been used, and Upland, Ind., is in the gas field, where many engines are in operation. In fact, there are so many in that territory that the action of the Upland Council, as detailed in the following, would seem to have been unnecessary:

"The city dads took action Monday night looking to the annihilation of the noise produced by the festive gas engines. An appropriation of \$20 was made and placed at the disposal of a committee to investigate and experiment to ascertain the proper method of procedure necessary to muzzle the exhaust."

Had the committee merely spent \$1 of that \$20 for a year's subscription to THE GAS ENGINE and asked the editor of the "Answers to Inquiries" for the information required, the town could have saved \$19, or the committee could have made something out of the deal.

In starting up a tube igniter at Duluth last winter the engineer turned on the gas for the gas burner to heat the tube, but did not light the gas for several minutes, and when he did there was, of course, an "explosion," but the reporters got hold of the incident and reported that the large engine at the city water works had been seriously injured by an explosion.

A common accident in cold weather is detailed in the following clipping from an Indiana newspaper:

"The gasoline engine at the lumber yard froze up Saturday night and bursted. The water is used in the engine to keep the cylinder from becoming overheated while in use, and they failed to draw it off that day when quitting work."

Sometimes, however, serious accidents do occur, as must be the case until the time arrives when machinery construction and machinery operation both come into a millennial period. The following is all the explanation I ever was able to secure regarding an accident at Huntington, W. Va., last December:

"The wheel of a gas engine, which exploded at the mouth of the Little Gypsy mines on the Tug River today, sailed half a mile down the mountain side and instantly killed Herbert McCourtney and a mule which he was harnessing. Two Hungarian

miners were slightly injured by the explosion. The flying wheel struck the mule's head, killing the animal instantly, and then, glancing off, struck McCourtney in the stomach. He was dead when reached."

Evidently the operator of an Illinois engine got a "little rattled" when the following occurred:

"The gasoline engine at the elevator became uncontrollable Saturday. The only means by which it could be stopped was to sever the tube connecting the engine with the gasoline tank. Before this could be effected considerable damage was done to the foundations."

Certainly the foundation must have been too weak in the first place, and surely disconnecting the battery wires or turning off the hot tube burner would have been an easier way to stop the engine than to break the connection of the gasoline tank.

The predicament of the operator described in the following clipping was certainly a most dangerous one, and the man owes his life to his presence of mind, providing, of course, that the newspaper account is correct:

"Mr. L— was working around a gas engine when one of his arms caught in a fly wheel. He was thrown into the air, alighting between the two fly wheels in such a position that the spokes of one of the wheels struck one of his feet. Fortunately, the foot did not slip between the spokes, as it would have done had Mr. L— lost consciousness, and he would have been killed. As it was, he was badly bruised on one arm and one foot. His eye was blackened by a blow received somewhere in the scrimmage with the engine, and it is not unlikely that bones of the arm were broken. Friday the arm was so badly swollen it was impossible to tell. While being tossed about by the engine Mr. L— never lost his presence of mind. As he went up in the air he yelled, 'Stop the engine-' and he managed to prevent his leg being broken by the fly wheel until the engine was stopped."

An English firm has put on the market a portable suction gas producer and gas engine. An air cooler, consisting of tubes through which the gas passes from the generator to the coke scrubber, is used. The total weight of a 12 H. P. outfit is about five tons.

A HIGH PRESSURE WATER SYSTEM AT CONEY ISLAND, N. Y.

Coney Island, the seaside resort near New York City, is to have a high pressure water works system. As is usual with such resorts, the buildings are nearly all one or two-story frame structures, and they are located close to each other, so that the building section of the resort is congested and subject to a very disastrous fire should a fair headway be secured. The location of the island, ten miles from the center of Brooklyn, of course precludes much assistance from the city fire departments.

The new system will furnish 3,500 to 4,500 gallons of water per minute under a pressure of 150 pounds per square inch at full capacity of the station. The building will be 37x62 feet, one story, brick, with concrete foundation. Three vertical, triplex, double, acting pumps will be driven by direct connection with 175 H. P., vertical, three cylinder Nash gas engines operating on artificial gas. A consumption of not to exceed 20 cubic feet

of gas (having an average calorific value of 650 B. T. U) per B. H. P. per hour is guaranteed. Fresh water will ordinarily be furnished by the pumps, but in an emergency connection can be made to salt water supply.

The engines are required to attain full speed and produce the maximum pressure at the pumps in one minute, the method of starting being as follows: Each engine is started with the valve on the by-pass connection of its pump open and when it has attained full speed this valve is gradually closed by an electric motor, which stops automatically when the valve is fully opened or closed; the pump then begins to deliver water to the mains. A relief valve on the discharge of each pump may be set at any desired pressure up to 200 pounds. When the pressure in the main exceeds that at which the valves are set, the valve opens and the pumps discharge through suitable connections into the overflow.

SOME GAS ENGINES AT THE LIEGE EXHIBITION.

At the exhibition held this summer at Liege, Belgium, there are exhibited a group of gas engines by the John Cockerill Company, of Seraing, which stand in an enclosure at the south end of the Machinery Hall in the Belgian Section. It is now close upon a hundred years since the founder of this gigantic concern, after whom it is named, first put up engine works at Seraing, and such has been their development that they now combine under one management coal mining, iron smelting, steel making and machine construction. Some few years ago two of the company's engineers, in conjunction with the late M. Delamare-Deboutteville, induced the general manager to undertake the construction of large gas engines for the direct utilization of blast furnace gas, and it is estimated that, when used in this way, the gas exerts five times the power it affords when it is simply employed for firing boilers.

The largest engine shown is of the horizontal kind, and is of 1,200 B. H. P. It is

a four-cycle, double-acting tandem engine, for consuming blast furnace gas, the cylinders being 39 inches in diameter, with a 43-inch stroke, and the speed 100 r.p.m. Close to this is a horizontal 500 H. P., four-cycle, double-acting, twin-cylinder engine, for coke oven gas, built for the company's electricity distribution service, and is supplied with ordinary gas. The cylinders are each 24 inches in diameter, with a 32½ inch stroke, and the speed is 135 r.p.m. The cylinders of both engines are of cast iron, with cast iron covers; they are water jacketed in the usual way—large openings being provided in the outer casing for cleaning-out purposes. The crank-shaft bearings are of cast iron, lined with white metal, and are adjustable for wear. The engine is provided with an outside bearing. The pistons are of cast steel, with cast iron packing rings. The piston rod is hollow, of forked steel, supplied with water circulation, which, in the tandem engine, extends to both pistons. The crosshead slides are

of cast iron, lined with white metal. The connecting rod is of forged steel. The crankshaft is built up, and consists of forged steel pin and shafts, with cheeks of cast steel in one piece, with the counter weights. The company also shows a vertical 150 H. P. twin-cylinder engine for blast furnace gas. The diameter of the cylinders is 12.75 inches, the length of stroke being 1 inch

more, and the speed is 280 r.p.m. A small horizontal single-acting gas engine, which also forms a part of the display made by the company, is of interest from a historical point of view, as it was built by them for the experiments they carried on in 1895 and 1896 with the object of testing the applicability of blast furnace gas for use in internal combustion motors.

THE MECHANICAL EFFICIENCY OF THE GAS ENGINE.

BY W. H. BOOTH.

Engineers have long been accustomed to the steam engine and have become accustomed to expect from it a mechanical efficiency of 90 per cent, by which they mean that of each 100 H. P. shown by the indicator they would be able to obtain 90 H. P. on a brake test. But it is overlooked that there are two steam impulses each revolution, and that, given equal lubrication, that engine will have the highest efficiency which has the highest mean pressure. The frictional loss of, say 10 per cent, is therefore a variable quantity. If we assume that the mean pressure per stroke is 40 pounds per square inch, the use of 10 per cent of this pressure in order to overcome friction will represent a useful pressure of 36 pounds applied to doing work and 4 pounds applied to keeping the engine in movement.

Supposing, now, that in an endeavor to render the engine more economical by extending the expansion of the steam—that is to say, by cutting off earlier—the mean pressure is reduced to 30 pounds. Then the useful work is represented by 26 pounds, and the lost or frictional work, in place of being 10 per cent of the total, is now 13.3 per cent. This, of course, assumes that the frictional load of the engine is a fixed quantity, but the figures are at least sufficient to indicate that the frictional losses of lightly loaded engines are greater relatively than the losses in heavier loaded engines. This increase in frictional loss is one of the many causes which step in and reduce the effect of every effort that is made to secure economy. The apparent effect that it should be secured is invariably greater than that actually attained. In brief, we learn not to attempt to secure too much; for, if we require, say 100 H. P., and we attempt to se-

cure this from a large engine with an early cut-off, we at the same time add to the frictional loss of the engine, and also to that very numerous series of heat losses comprised under the terms radiation and cylinder condensation. These losses when added up are what put a comparatively early limit on the attempt to secure economy by prolonged expansion, well enough in itself, but limited in practice by the foregoing considerations.

The same reasoning applies to the gas and to the oil engine, but to a very much greater extent. Practically all these engines work on the Beau de Rochas cycle or the four-stroke cycle; that is to say, they only have one working stroke in four. Let us see how this affects economy. To do so, we will employ the steam engine as an illustration to help us to gain clear ideas. Let us assume a steam engine of high class with a load of best efficiency and a mechanical efficiency of 94 per cent. The frictional loss is 6 per cent, and there are four working strokes for each two revolutions. Suppose, now, that we so alter the engine that steam is admitted once only in two revolutions, so that the engine is placed on an equality with the gas engine. Assume that ordinarily it was of 100 I. H. P. and that it lost 6 H. P. by friction. When placed under its new conditions it will still lose the same 6 H. P. by friction, but its total horse-power will only be one-fourth of 100 H. P., or 25 H. P., and the frictional loss in terms of this reduced figure will be 6 times 4 equals 24 per cent.

One may often hear complaints made of the gas engine that the mechanical efficiency is so low. This is charged against the gas engine as though it were some fault of the mechanical construction of the engine. But

this is quite an erroneous view. Any gas engine which shows an efficiency of 76 per cent is actually running with a frictional loss of only 6 per cent per stroke, for if every one of the four strokes could be made into a working stroke the total power of the engine would be quadrupled and the frictional loss would only be as before. Thus, in the case in point, where a gas engine of 25 I. H. P. shows a loss of 6 H. P., or 24 per cent, its power would be 100 I. H. P., were it possible to produce an explosion every stroke instead of at every fourth stroke. It is perfectly easy to design a gas engine that will give two working strokes per revolution, but to do so would require a gas pump and an air pump, to pump gas and air into reservoirs, whence they would be fed to the engine and exploded. The charge might either be fed at full compression into the engine or it might be fed at a lower pressure as a scavenging stroke and compressed by the engine. Indeed, this system is already fairly common. But all this requires a certain complication of mechanism, and it demands air and gas pumps and the means of driving them, and the engineer who wishes to get more than 70 to 76 per cent out of a gas engine has still to sacrifice power in driving pumps, and it may not turn out that he is any better off in the end. He would, however, succeed in reducing the dimensions of his actual working engine, and it is possible to imagine a number of gas engines all working independently of each other and taking their supply of gas and of air from a common reservoir, kept pumped up to the proper pressure by means of one engine whose duty was confined to this one thing only.

Possibly some economy might be secured by such a scheme well designed and carried out, for it would certainly enable the gas engine to be reduced to one-fourth of its present cylinder area for a given power. One of the best of our experts in gas engines has pointed out that if our atmosphere were several times more dense than it is at present there would be no call for compression in gas engines. Compression, in fact, is merely a necessity by which we are able to secure economy in working within reasonable temperatures. We should, of course, secure more economy if we employed a higher compression. This can not be done on account of pre-ignition.

From what has now been said it will be

obvious that as a rotating machine the frictional resistance of a good gas engine is not higher than that of a steam engine, and the only reason why the mechanical efficiency is low is that in the gas engine only one-fourth of the total number of strokes are made working strokes.

The efficiency of the gas engine would be even lower than it is were it not that the mean pressure per square inch is so much higher than in the case of the steam engine. These same full power Diesel diagrams show 110 pounds mean pressure. Even a blast furnace gas engine, working on Thwaite's system, has shown about 65 pounds. It is only by such high pressures that the dimensions of gas engines for a given duty are not much greater than they are. Thus, if the mean pressure were kept down to the 40 pounds very usual in steam work, the gas engine would be from 50 to 100 per cent larger than it is for a given power and its frictional loss would be similarly larger. With pressures what they are, gas engines may be said to lose in friction about 6 per cent, multiplied by 4 divided by N , where N is the number of working strokes in two revolutions.

Steam engines lose in friction about 8 per cent multiplied by 4 divided by N . Equally well made machines practically lose about the same percentage of power if reduced to equal mean pressures, and this is what a constructing mechanic would expect, for there is little in gas or in steam to warrant anything else. As no saving can be made in the gas engine friction except by transferring some of this to separate compressing pumps, we may take it that the mechanical efficiency of the gas, or, to speak generally, the internal combustion engine, is a function of the principle on which it works, part of the price which has to be paid for the abolition of the boiler and separate furnace, or for the fact that our atmosphere is of its present density. This, of course, we can not help. It is the result of the quantity of air which has been furnished to our earth or of the amount that it has been able to retain against the molecular kinetic energy of gases in promoting their escape. We can only counter the small density of the atmosphere in heat engine work by adopting compression, and we can only employ compressor so far as not to obtain temperatures above what can conveniently be dealt with.—*Power.*

ANSWERS TO INQUIRIES

It is our purpose to answer in this column inquiries of general interest which relate to the gas engine or its accessories. The questions will be answered in these columns only, and we reserve the privilege of refusing to answer any question which is not, in our judgment, of interest to the subscribers of THE GAS ENGINE.

All matter intended for this department should be addressed to The Editor of THE GAS ENGINE, Blymyer Building, Cincinnati, Ohio. The name and address of the sender must accompany the inquiry in all cases as evidence of good faith. The initials only of the sender will be published, together with the postoffice and state.

Write on one side of the paper only, and make all sketches and drawings on a separate sheet. Mark each sheet with the name and the address of the sender.

(a) What is the proper compression for an engine running on producing gas? (b) What power would we likely get out of a three-cylinder engine, 13 x 14 inch cylinders, running 170 r.p.m., with everything in good shape? The engine is a Westinghouse gas engine, 125 B. H. P.

B. L. C., Berlin, Ont.

(a) The proper compression of a producer gas engine depends on the chemical composition of the gas, which varies to some extent, according to the fuel used in generating the gas. The compression runs from 150 to 230 pounds (absolute) per square inch. (b) The power secured from this engine would depend on whether or not the engine has been designed for use with producer gas, or whether it is a "city gas" or natural gas engine converted to the use of producer gas. In the paper by Mr. Wyer, in another column, will be found the following: "No gas producer plant can be successful unless the gas engine is adapted to suit the particular gas available for its use. On the authority of Westinghouse, Church, Kerr & Co., an engine which will develop 100 H. P. with natural gas will give only about 80 H. P. with producer gas, a loss of about 20 per cent. With a 200 H. P. engine this loss would be about 15 per cent, and with sizes above 300 H. P. it would be about 10 per cent. Hence the obvious necessity of designing the engine to suit for the particular fuel it is to use. Sev-

eral failures have been made by neglecting this important point." If, therefore, the engine referred to is rated at 125 B. H. P. on natural gas, it could not be expected to develop over about 100 B. H. P. on producer gas.

(a) Is there a book published from which I can ascertain the thermal value expressed in heat units of all fuels which can be used in an explosive engine, such as the different grades of alcohol, gasoline, benzine, naphtha, anthracite and bituminous coal, illuminating gas, etc.? (b) I also wish to know the point to which it would be necessary to compress each of these gases mixed with air, to cause them to ignite from compression.—G. F. M., New York City.

(a) More or less complete tables of this kind may be found in "Roberts' Gas Engine Handbook" (page 21), "Homan's Self-Propelled Vehicles" (page 228), "Hutton's Gas Engine" (page 58), etc. One of the most complete chapters we have seen on thermal units and the calorific power of fuels is contained in "Sexton's Producer Gas," reviewed on page 178, June issue of THE GAS ENGINE, the price of which is \$4.00. This work, however, uses many European terms, and gives the heat values generally in Centigrade terms, but these may easily be converted to B. T. U. (b) We do not recall ever having seen such a compilation. Perhaps some of our readers can refer us to some work giving this information.

(a) Is the following correct for the rules of the American Power Boat Association: "Area piston in inches by stroke in feet by r.p.m., divided by 150," and should the speed be taken at full lead of propeller, propeller having reversing blades? (b) Does the enclosed sketch and formula give correctly the actual H. P. of the engine? (c) How far ahead of the dead center should the spark be advanced to obtain the best results? (d) The builders say my engine should turn 600 r.p.m. with full load on propeller and develop 31-3 H. P. I can get only about 350 r.p.m. and less than 1½ H. P. Can you help me? The engine is a 4 inch by 4 inch. (e) Will the engine give greater speed with the jump spark than with the make-and-

break, and is the jump spark reliable?—A. S. M., Avelon, Cal.

(a) The formula is correctly stated, but this denominator is too small; it should be 825. (b) Yes, if diameter is taken in feet.

(c) About 30 at 600 r.p.m. (d) Your trouble is probably due to having too bluff lines in your boat; and, as you say it is an auxiliary, we are quite convinced that this is the cause of your difficulty. (e) Generally speaking, yes, because of the ease with which the lead can be adjusted.

I am constructing a double-cylinder, two-cycle marine engine, 7-inch bore, $5\frac{1}{2}$ -inch stroke, exhaust port 1 inch by $3\frac{3}{4}$ inches, inlet port 11-16 inch by $3\frac{3}{4}$ inches, connecting rods 13 inches between centers, fly-

wheel 22 inches diameter, $4\frac{1}{2}$ -inch face. There will be perfect suction and compression in the crankcase, no loss whatever through shaft bearings. The compression space is $1\frac{5}{8}$ inch; the engine is to run at 500 r.p.m. (a) Do you think these measurements will give satisfactory results? (b) How much B. H. P. should this engine develop? (c) What size propeller and what pitch should this engine turn for a boat 40 feet by 7 feet 3 inches, —W. T. B.

(a) Make exhaust $\frac{7}{8}$ inch by 4 inch, inlet 11-16 inch by 4 inches, rods 11 inch center to center. The other dimensions are O. K. (b) 22 H. P. (c) It will depend somewhat on the boat, but we would suggest a propeller 18 inches in diameter, 28-inch pitch.

SOME EUROPEAN GAS ENGINE OUTPUT.

Up to 1896 Koerting Bros., of Hanover, had turned out about 3,500 gas engines, aggregating 15,000 H. P. Since that time they have produced 7,200 new engines. In recent years they have built 50,000 H. P. in two-cycle engines and 100,000 H. P. of the four-cycle type.

The Cockerill Company and allied companies building their engines are credited with 148 engines up to date, with a total of 102,925 H. P., of which 45 per cent are used for electrical service and 52 per cent for blast furnace blowers.

Of the Otto Deutz engines, since the formation of the company forty years ago,

nearly 70,000 units have been put out. In 1902 the company began building double-acting engines, and since then 46 engines, with a total of 31,500 H. P., have been built by them and their concessionaires.

From 1903 up to the end of November, 1904, the Nurnberg Company had supplied and had in hand 106 double-acting engines, aggregating 114,070 H. P.

Within three years the firm of Ehrhardt & Sehmer, in Alsace, built 15 double-acting engines, representing 12,680 H. P.

The above data has been selected from M. Mathot's paper, an abstract of which is given on pages 234 to 238.

GAS AND OIL ENGINES IN SWEDEN.

According to the report of the British Consul at Stockholm, during the last year the use of gas, gasoline and oil engines increased considerably in Sweden, and interest and confidence in them are growing steadily. It is evident that there is a wide field for these motors, especially where small power is needed. The supply is both foreign and native. Thus engines from the United Kingdom, United States, Germany and France are to be found, together with those of Sweden. Of gas engines, the suction gas variety seems to take the first place, and is generally employed in sizes up to

about 100 H. P. They are mostly used in factories and for electric power stations. The majority have till now been imported from the United Kingdom and Germany, but the home manufacture is increasing. They are, without exception, of the four-cycle type. Gasoline or benzine motors are mostly of small sizes, such as 3, 5 or 7 H. P. They rarely exceed 40 H. P. The United States has so far supplied the majority of them, but several Swedish firms have begun building this class of motors. Oil engines are to be found of all sizes from 1 up to 200 H. P.



Chicago, being up to date, is going to have an automobile fire patrol.

Now that France has won the Gordon Bennett race twice in the last two years, she considers herself at liberty to withdraw from it in the future without any one saying that the *sub rosa* reason is that she can't win.

An experienced driver suggests using for water-cooled motors in the summer oil recommended for air-cooled cylinders, this being a thinner oil, and there being less danger of overheating of the cylinder in hot weather if such an oil is used.

Lubrication is a matter of importance to users of any kind of machinery. It is of particular importance to the automobile user, for in case of failure to lubricate properly the delays and expense constitute a very considerable item in the "general reliability" of the car. Mechanical lubrication is one of the developments of the high-speed motor which has come within the last three or four years.

We are pleased to be able to publish this month the first installment of an article on European tendencies in gasoline automobile construction. This article deals chiefly with ignition and the author has attended all of the large European exhibitions of the current year, thereby being able to gather much information along this line. Being a designer and engineer, he naturally passed over much of what he calls "the clamor and racket, the rhetorical, musical, illumination and pictorial performances," and is able to give ideas of construction, which would not be noticed by one out of twenty visitors.

Delivery by automobile is a matter which is receiving increasing attention by merchants of all classes. At the last conven-

tion of Ohio laundrymen the matter was taken up in a paper, and there was considerable discussion on the subject. Coal dealers, furniture dealers, hardware stores, general stores, in fact, every class of retail and wholesale merchant, is beginning to give the matter some thought. The thing which they lack is confidence. When the manufacturers will take steps to prove to them that the machines are reliable and that there will be a saving in the cost of delivery by this method they will be more willing to venture. And it is right along this line that there is going to be the greatest development and future for the self-propelled vehicle. While there will be an increasing field for pleasure cars, it is the commercial vehicle or the commercial use of other types of cars that will offer the final and greatest field of development and utility.

We have always favored reliability and economy trials as the best class of trial for the automobile, outside of the tests of general usage by the public. There are, no doubt, some people who are impressed with the value of a runabout or a touring car, as shown by the fact that possibly a very different type of car has won some great races. But the majority of purchasers want to know what class of service they are going to get in the car they happen to be using themselves, and what the cost of operation is going to be. And yet in the purely consumption tests it must be borne in mind that the driver of the car is endeavoring in every possible way to keep down the quantity of fuel used. For instance, every down grade is taken advantage of, and, while in ordinary usage the operator might not wish to cut off the power for the slight advantage to be gained in "coasting" in this way, yet it enters into the contest for economy of fuel. The contestant's only idea is to get through in the limit of time, with the least possible quantity of fuel used.

SOME EUROPEAN TENDENCIES.

BY OSWALD H. HAENSSGEN.

The frequent automobile shows held at present are no doubt one of the best means to make the great public acquainted with the immense progresses achieved in this rather young industry. That the interest in the most modern means of locomotion is not confined to sporting circles, but is also of interest to all classes of people, is proven by the crowds generally thronging the exhibition halls and keenly and patiently watching the performances of the cars on the course.

It is a well known fact that beyond those novelties which at once catch the eye even of the lay visitor, a show generally contains many extremely interesting objects of perhaps unsightly appearance that are mostly overlooked by the passers by, but surprise the careful student by their inherent value.

The art of automobile building has entered upon a stage in which revolutionizing changes seem improbable, improvements are at present made in the details. The designers try to bring up every part, even the smaller one, of the motor car, to the highest degree of effectiveness, well knowing that on the perfect co-operation of all details depends the ultimate success.

In the following lines the author is now going to depict the common and ever-repeated exhibition clamor and racket, the rhetorical, musical, illuminatory and pictorial performances intended to allure the pleasure-hunting crowds or to act as advertisements. He rather wants to call the attention of the reader to just such little details of the afore-mentioned character, as far as he could discover them.

Naturally the motor proper receives the most care and the improving process extends principally on the valve motions, ignition and the vaporizers.

The author may be permitted to criticise a rather peculiar and disagreeable outgrowth of the automobile industry. Looking at the catalogues of most automobile motor makers it will be noted that generally the motor is listed without accessories, that is, the price is given for the plain engine without governor, igniter or source of current, and generator for the mixture. Of course, the maker will furnish these parts upon demand, but besides giving no clear

idea about the actual cost of the complete engine, this practice leaves too much liberty to intermediate persons to fit the motor up with cheap and unsuitable devices. Thus many an engine of perhaps excellent test-stand qualities is often enough rendered partly unfit and a source of never-ending trouble for the purchaser. It may look like good business practice to cater to the needs of the public, whether real or imagined, but to follow indiscriminately the ever changing contingencies of the fashion to which, sorry to say, automobilism is subjected at this time, is, considered from an engineering standpoint at least, a rather degrading condition.

Is not the motor designer and builder, on account of his long-time experience, his extended practice and his most perfect test-stand facilities, better able to decide just which accessories are best adapted to his particular make of engine, than the prospective buyer? Should not his advice, which is based upon the combined experiences of hundreds or perhaps thousands of motor users, be sooner heeded than the decrees of fashion?

The manufacturer can not be held responsible for the perfect working of his motor unless all the details are under his control. If he wants to furnish a good motor he must fit it with all its accessories to the best of his knowledge, test it thoroughly under various loads and run it till the perfect co-operation of all parts is secured. In this condition the motor is delivered to the customer and can not fail to give satisfaction. If the latter, however, believes he knows better and prefers to change one part or the other according to his liking, he does so on his own risk and his action releases the manufacturer of his guarantee. In order to avoid subsequent complaints as to the guarantee the manufacturer should clearly state his business principles in his catalogues and other printed matter.

Another bad practice oftentimes met in the motor industry, and which in its results is similar to the one just spoken of, might also be criticised here.

The author knows many shops in which a series of motors are tested in succession with a single set of accessories, such as va-

porizers, igniters, magnetos and oil cups or the like. After testing, the motor is stripped of all these parts and they are replaced by entirely new ones taken directly from the store room. Of course, these later parts are thus protected from the oftentimes rough usage on the test-stand, and repolishing, for instance, is saved. Naturally the new parts have not yet seen any service, and, possibly, refuse to work properly. The slight gain is bad economy, as the manufacturer is compelled to ship an engine, the properties of which are not certainly known to him. Thus he has no positive proof that the substitute will behave exactly like the original, which remained on the test-stand.

The only remedy is the same as in the foregoing case.

In the present automobile motor the four-cycle system is yet chiefly represented, though the two-cycle motor is also coming to the front. A few engines of this kind were shown on late exhibitions and aroused a more than passing interest with the public.

How much has already been written about motor ignition! And yet the material seems inexhaustible, novelties are chasing each other—and disappearing about just as quickly—each device is, by its makers, of course, claimed to be the best, while the customers generally find that even the most perfect appliances yet cause trouble enough.

One thing is definitely settled, though: Electric ignition has been victorious on the whole line, no modern motor is equipped with anything else.

As to the sources of the electric current: storage batteries and magneto-electric generators prevail, dynamos are much rarer, and primary batteries are practically never used, except in the shape of dry batteries, as a reserve only.

Frequently the motor is provided with two complete igniter outfits that are entirely self-contained in their details. This is a very commendable practice, but calls for considerable judgment on the part of the operator. Thus a storage or dry battery may be arranged to work in alternation with a magneto or a dynamo. The ready current of the battery may serve to start easily the powerful multi-cylindereed motor, the mechanical generator takes up work as soon as the motor has gained sufficient speed. In case of an emergency, however, each detail of one ignition system forms a reserve for the similar part of the other.

thus the battery alone will suffice to work the engine for a considerable time. Often each cylinder is equipped with either two spark plugs or one spark plug, and one make-and-break igniter. Necessarily, each source of current must have a separate timing device, with direct jump spark ignition. This important and tender apparatus is at present frequently arranged near the top of the engine and rotated by a special vertical shaft. Thus the contact pieces are easily accessible. The magnetos generally carry the timing device on their own shaft, while the dynamos furnish a continuous current work with the same appliances used for the batteries.

The low tensioned current is transformed to the high pressure necessary for jump spark ignition by so-called spark-coils, which, for battery current, are mostly provided with vibrators; the spark coil may be separate, or may form an integral part of a magneto. In this latter case no vibrator is used. The increased voltage of the ignition current calls for perfect insulations to prevent leaks. Consequently the high tension wires are strongly insulated with a thick coat of rubber and are, besides, carefully protected by hard rubber or wooden tubes. These are in turn re-inforced and held in position by brass or copper fittings. The connection with the binding posts is made by more or less ingeniously constructed pole shoes. The switches, which hitherto were frail devices that seemed to be taken from the telephone or bell service, have been replaced by formidable looking structures of fibre, slate and metal, such as are used in high tension electric plants.

The modern magnetos for make-and-break ignition require no spark coils. They work in conjunction with igniter-flanges that are operated in the time-honored manner by cams, levers, springs and rods. Though there is a notable tendency to simplicity and improve these noisy and ill-wearing devices, the success is not yet very great, and there is yet much occasion for perfection. The interrupter flanges have considerably profited from the experiences gained with jump spark plugs, in so far as the former are being equipped with the more perfect insulations of the later. In fact the stationary electrode is practically nothing else but a spark plug of which one wire point has been omitted, while the other has been much increased in size.

The jump spark plugs assume many vary-

ing shapes at present. There is scarcely any other motor detail which has received so much thought as this little device. And yet, in spite of all the care bestowed on them, the plugs are just as unreliable as ever, that is to say, the never-failing plug is not yet found, and probably never will be.

A prominent sportsman, the manager of a renowned automobile works, said: "All spark plugs are excellent, but no one is any good at all! Take along a dozen of the cheapest ones, worth about fifteen cents apiece. If one gives trouble throw it away and insert another."

This seeming contradiction is justified by the experience of nearly every motor operators. One plug will work for months, another of the same make may give out in the first few minutes. Or a plug which works perfectly in one make of motor fails utterly in another.

There is no doubt that to a great extent the causes for these puzzling differences are not so much in the spark plug itself, but in its surroundings, that is in the motor. Probably by dint of experimenting the plug best suited to an individual motor could be discovered.

Improper location of the igniter, imperfect combustion, exaggerated oiling and many other causes may be responsible for partial or complete failure. Many of the plugs on the market have also faults of their own and will never work satisfactorily. These shall be criticised later.

A few types of igniters have also been brought out in which the interruption of the electrodes is caused by the action of an electro-magnet.

While the foregoing introduction briefly outlines the present state of the ignition question, but by no means claims to be complete, the following lines shall be given to a more detailed appreciation of the various improvements and novelties.

As a source of current for ignition purposes the storage battery enjoys great favor yet. The novelties in this kind of apparatus are of a character so strictly electrical, however, that they do not much interest the mechanical engineer. Besides, they are often too difficult to recognize for those who are not electricians. There are some improvements of a more structural nature that appeal even to the less informed.

The cases for the cells are mostly made of transparent celluloid which allows an easy inspection of the interior. The most important parts of a storage battery are the leaden gates that carry the so-called active matter. They are made in many different ways, with the object to lessen their weight and to increase their durability and capacity. Notably is the construction of the plates in the batteries made by Mr. Paul Gadot, of Paris, France. As sketched in Fig 1, the plates consist of two grates (1) each, the bars of which are of triangular section. The grates are so connected by rivets (2) that dovetailed pockets (3) for the reception of the active matter are formed. The latter is thus safely held in place. In order to increase its active surface each block is perforated. The manufacturer also furnishes closely fitting sheet metal boxes for the protection of the cells. Their interior may be readily examined by two round holes cut in opposite walls of the metal box.

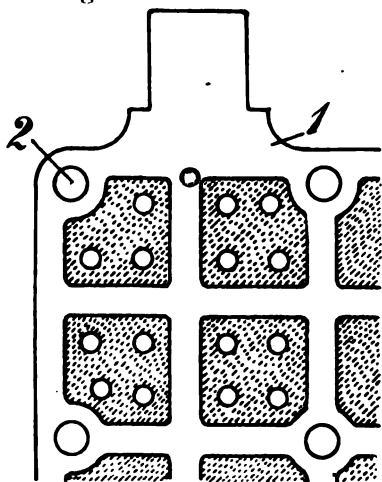

Fig. 1.

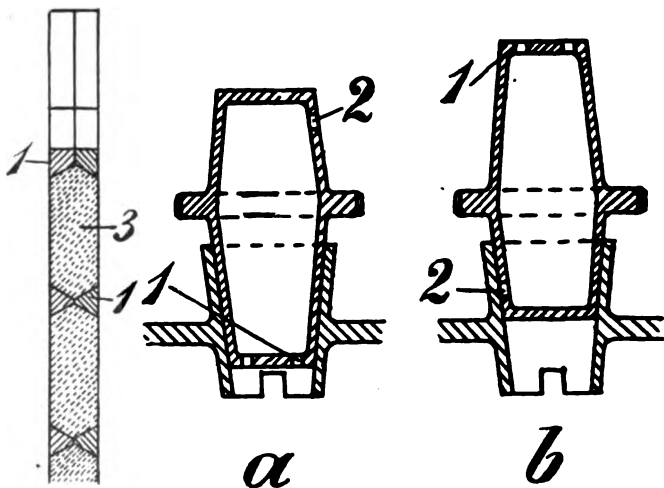

Fig. 2.

The batteries of the "Union" brand are claimed by their makers to be chargeable in five hours and to retain their charge without noticeable loss during several months, when not in use. Just what peculiarities of construction are responsible for these properties, could not be learned; anyhow, the batteries are very well made and easily taken apart if repairs become necessary.

The storage batteries "Invicta" have a fusible lead wire between the negative pole of one element and the positive pole of the other, whereby overloading and the damage resulting therefrom are avoided. They are also provided with a patented plug, Fig 2, that prevents the spilling of the acid while it lets the gases escape. The plug is a hollow double tapered body, both ends of which fit tightly the nozzle of the battery casing.

Sketch a shows its position during service, the gases may escape freely through the little holes (1) and (2) while any liquid carried up into the hollow of the plug comes to rest within and eventually flows back.

Sketch b shows the plug inverted, as for shipping, for instance. In this position hole (2) is covered by the wall of the nozzle and the cell is hermetically sealed. The plug is made of transparent celluloid.

The same company offers a nice little device for charging storage batteries. It is called "Le Discret," is of small size, to be carried in the pockets. It consists of a board of about 4 by 3, upon which are mounted a standard incandescent lamp socket, a switch and four binding posts. Two short insulated wires terminating in a plug similar to the foot piece of a lamp, and fitting into the standard lamp socket, are connected to one pair of binding posts, while the other two are intended to receive the wires leading to the battery. In order to charge the latter a lamp is withdrawn somewhere and placed in the socket on the board. The plug belonging to the outfit takes the place of the lamp. When the current, which, of course, must be continuous, is turned on, the lamp lights up and serves as a resistance. Thus part of the current enters the battery and charges it. The charging process lasts several hours and must be controlled by a voltmeter.

This little outfit is in fact a very handy device to do its work discreetly—as its name suggests—stealing the current in hotels or private rooms. It may be a good investment for a foxy auto driver.

The firm also produces little transforming plants that serve to charge several batteries at once. They consist of a small electromotor directly coupled with a dynamo, both mounted on an iron bedplate, with the ammeter and voltmeter between them. The motor is wound either for continuous current of 110 or 220 volts, or for alternating current. The dynamo generates continuous current of ten amperes maximum at eight volts. The energy to run the motor may be taken from the electric service wires or any other suitable source.

The batteries "L'Energique" are, so to say, a mixture of a storage and primary battery, being charged like the former and sustained in their action by the consumption of material like the latter. A battery of this type consists of the casing in which quite close to opposite walls the two positive electrodes (1) and (2) Fig 3, are fixed. These

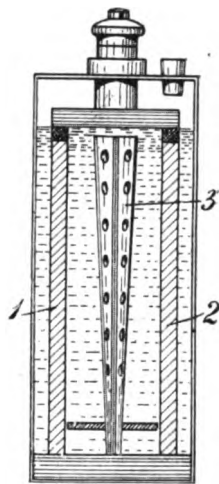

Fig. 3.

are formed by large plates of peroxyde of lead. Between them is arranged what is going to be the negative electrode. This part (3) is made of perforated sheet lead coated with antimony and doubled up so as to form a funnel-shaped pocket. The casing is filled with a mixture of distilled water and sulphuric acid. This battery may be shipped in a charged condition without containing any liquid. Upon arrival it is filled with the diluted acid as directed. In this shape the tension at the poles is scarcely one volt. In order to get ready for work a stick of a special alloy is put into the pocket of part (3). This stick practically serves as the

negative plate. Its composition is kept secret; it seems to a metal somewhat like zinc. Shortly after the introduction of this alloy the voltmeter will register a tension of 4.4 volts. But yet the battery does not work on open circuit as the metal is not acted upon by the acid. If, however, the circuit is closed the alloy is gradually consumed while current is being given off. When the voltage drops, a fresh stick is put into each cell, until the reserve furnished with each battery is consumed. Recharging then becomes necessary. For this purpose the liquid is poured out, the casing thoroughly revised with clean water, fresh liquid filled in and the battery charged in the customary manner.

The battery "L'Energique" has the following features that render it especially advantageous for ignition service:

Its output is practically constant, the supply of energy left is recognizable by the amount of alloy remaining in reserve. An exterior short circuit does not do any damage: as soon as the alloy within the battery is consumed the circuit is open. Without the alloy the battery is completely at rest. It retains its charge indefinitely and is of a stick of metal.

The magneto-electric generator is gaining more and more popularity. Its oscillating type has, of course, completely disappeared, as it was found to be impractical in the modern high speed engines. The common rotary kind which is extensively used in connection with make-and-break mechanisms is so well known and has undergone so few changes that a detailed description seems to be unnecessary. The durability and reliability of this machine has about been brought to perfection by many little improvements, as well in the electric part as in its mechanical construction. When the armature is supported in common bushings a liberal lubrication is obtained by the use of oiler rings, or the oil is brought to the shaft by wicks of felt. In many cases ball bearings are used. The little surface of contact offered by these bearings causes a difficulty that must be overcome in some other way, as the current finds too much resistance in passing from the rotating armature to the body of the generator. In the magnetos of "Bosch" manufacture a copper collar is fixed on one of the shafts carrying the armature. A carbon plug, guided in brass bushing, is gently pressed upon the

rotating collar by a little spring, thus forming a most perfect conductor for the current, being at the same time easily cared for, adjusted or replaced, if necessary.

More interesting is the application of the magneto for jump spark ignition. Here two forms must be distinguished. In the more compact arrangement the magneto, with all the necessary electrical and mechanical adjuncts to form the spark within the cylinder at the proper moment, forms one self-contained unit which may be fitted to the motor with the least possible trouble. In the other form all these parts are left separate and thus much more care is necessary to fix them to the engine and adjust them in proper relation. The opinions of experts are still divided on this subject, and probably will remain so for a while yet. Certainly the compact self-contained generator has many fascinating features, but yet the separate arrangement offers many advantages also.

The modern magnetos of the former type are, especially for multi-cylinder engines, so complicated and require such delicate adjustments, that in case of defect only the manufacturer can get them in order again. The location of a trouble is so difficult that more than average intelligence is required. If, however, the important parts of the ignition system are separate, and all of them as well as the wiring in plain view, it will be much easier to discover the cause of a failure and to remove it. Especially the induction coil, which is often enough squeezed into the narrow space between the horse-shoe magnets, deserves a better place and should, therefore, be left separate. Thus it can be made of liberal size with the necessary amount of wire windings, well insulated and properly disposed. In the author's opinion the contact device might preferably be fixed directly on the shaft of the magneto as thereby the exact co-operation of the parts is always secured and a magneto of this kind offers just as little difficulties in fitting to the motor as the entirely self-contained type. The "Bosh" magneto is the classical representative of the latter type. It is built in various styles suitable for motors of all sizes and for any number of power cylinders from one to six. The principle of its operation, as well as its construction, have been explained in a previous issue of this paper (July, 1903) and shall be touched upon here briefly. The single cylinder types are built in two sizes. The smaller

one, made especially for bicycle motors, but applicable just as well to other small engines, weighs eight and one-fourth pounds. It is six and one-half inches long over all, including the tapered shank and the nut for fastening the driving wheel. Its width is three and one-fourth inches, and the total height is six inches. It has two powerful magnets, one nine-sixteenth inches wide and one-half inches thick. The next size is intended for motor up to about four-inch cylinder bore. Its weight is thirteen and one-fourth pounds. The total length is eight inches, its width three and one-fourth inches, and its height six inches. There are three double magnets one and nine-sixteenth inches wide and one-fourth of an inch thick. As is customary in most magnetos, one end of the shaft rotating the armature is tapered to receive the gear or sprocket that drives the apparatus, while on the opposite end of the shaft the interrupting device is placed. The latter is sketched in Fig 4. A disc (1) is keyed to the shaft of the armature. Fixed upon the disc (1) but well insulated therefrom is the piece (2). Both the disc, as well as the contact piece (2), are rigidly fastened to the shaft by a single screw bolt (3) which also forms the electrical connection of the winding and piece (2). The double armed interrupter lever (4) is pivoted at point (5) by means of a lateral pin entering a hole in the disc (1) and is held in place by a little link (6). A recess

in the side plate of the magneto housing receives an annular brass piece (7) from which extends a lever (8). Into piece (7) is fitted a fiber ring (9). Its inner circumference is concentric to the axis of the armature but about one-sixth of it is somewhat widened, forming a negative cam (10) by which the interrupter is operated. A flat spring (11) tends to push the platinum tips (12) together, but this is only possible when the head (13) of lever (4) drops into the notch (10). The moment of this movement may be changed by turning the brass piece (7). The whole device is covered by a dust proof casing (14) and the various parts are held in their places by the flat spring (15). This is pivoted to the body of the apparatus and by simply swinging it aside the parts drop apart and the contacts are open to view. A turn of the link (6) permits the withdrawal of the lever (4), while the other end is connected to the (1) may be removed. This arrangement is very handy for inspection and cleaning and is carefully designed. The only weak part seems to be the fiber ring (9) or rather the notch (10). There is no doubt that the ring will wear out pretty rapidly and thus become inoperative. Of course this may be remedied cheaply and quickly by substituting a new ring.

Besides there is no technical difficulty in replacing the wearing surface of the fiber ring by a more solid material, steel for in-

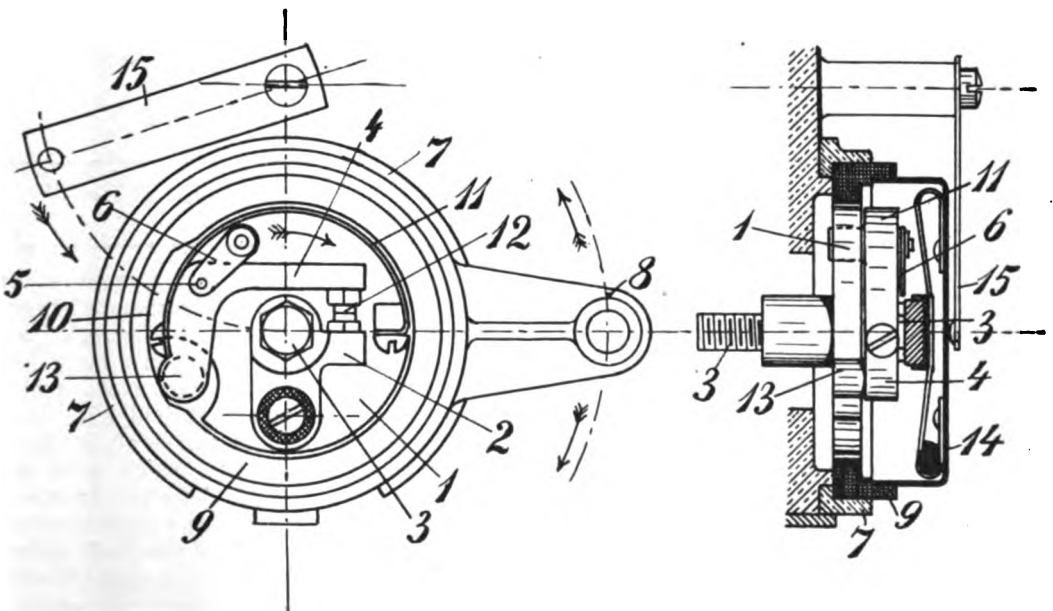

Fig. 4.

stance, and use the fiber only for an insulation.

The wiring of these magnetos consists of a primary coil and a secondary coil, both being arranged about the core of the revolving part. The core is of soft iron milled to H shape section. The primary coil is formed by a few turns of coarse insulated wire laid about the core, to which one end is fastened while the other end is connected to the bolt (3) (Fig. 4). To the same end is soldered the beginning of the secondary coil, which is made up of fine silk-covered

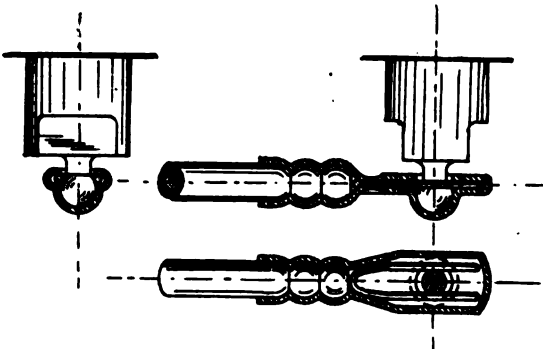

Fig. 5.

wire of great length and fills up all the available space about the core. The other end of this wire is soldered to the aforementioned copper collar near the driving end of the shaft.

The operation is as follows: The magnetism of the permanent magnets induced by the rotation of the armature a weak current in the primary wire, the tension of which attains a maximum twice during each revolution. The current travels through the

bolt (3) to the contact piece (2), passes the platinum tips (12), lever (4) and by the disc (1) returns to the metal of the core. Through the various parts of the interrupter device and its casing the primary winding is also connected to one pole of the condenser which is a special feature of the "Bosch" magnetos. The other pole of the condenser is in contact with the body of the magneto and thus with the core also. It will be noted that the condenser is connected parallel to the interrupter and serves to store electric energy. When by the motion of the interrupter lever (4) the contacts (12) are torn apart whereby the primary circuit is broken, the sudden kick of current in the primary wire induces a secondary current of very high tension in the fine wire windings. To this current is also added the discharge of the condenser. The result is a fat hot spark of excellent igniting qualities.

The moment of ignition is identical with the moment of interruption. It may be varied by changing the position of lever (8). It may be shifted thirty degrees, which means sixty degrees at the crank shaft of the motor and is more than required.

The secondary wire leading from the magneto to the spark plug is a peculiar device. The terminal of the magneto is ball-shaped. The clamp at the end of the wire is bored so as to slip over the ball, and a steel wire spring prevents it from coming out again. This little device is very handy, as it does away with the small nuts generally used, and which are so easily lost.

It is clearly shown in Fig. 5.

(To be continued.)

AUTOMOBILE TRANSPORTATION IN MINING DISTRICTS.

In the new gold-mining districts of Nevada, the stage-coach has given place to the automobile. There are sixteen automobiles in operation between Tonopah and Goldfield, the distance of thirty miles being done in one and one-fourth to one and one-half hours, as against the three and one-half hours consumed by the regular stage. The fare is \$5 by the old-fashioned conveyance and \$6 by motor. Between Goldfield and Bullfrog there are half a dozen machines in regular use, but the number is increasing. The distance between these two mining settlements is seventy-five miles, the run is

made in six hours by the automobiles for a fare of \$25, while by the six-horse stage-coach the charge is \$18 for a journey of ten hours. Special roads have been built for, and are used solely by, the automobiles plying between Tonopah, Goldfield and Bullfrog. Another road of this kind is being constructed to Las Vegas, which is on the new Salt Lake & Los Angeles Railroad. These facts are not without suggestiveness, as indicating the intense modernism of our Western mining districts and the quick utilization of mechanical ingenuity.—*Engineering and Mining Journal*.

A "REVERSE" MOTION.

Automobile Topics vouches for the following: A picnic party of four young men from Plainfield, N. J., became stranded midway on a long and steep hill between Bernardsville and Mendham a few days ago. The first car that came along was hailed with enthusiasm and delight, and its occupants applied to for help. The quick-witted driver of the car diagnosed the case as one of little gasoline; he then had the disabled car slewed

around until its rear end pointed up the steep hill. This caused the small remnant of gasoline to flow into the carbureter, whence it was sucked into the combustion chamber and used to furnish power to drive the car up the hill backward. Arrived there, the Plainfielders wanted to continue their journey stern foremost, but it was pointed out that this was not necessary on level roads.

AUTOMATIC CARBURETERS, CLUTCHES AND BRAKES.

Automatic carbureters are good things in their way, but, like many other good things, they require keeping thoroughly up to the mark, otherwise they are a much worse contrivance in actual working than where a carbureter is used in which no automatic device is employed. A great number of the automatic carbureters at present fitted to engines have a sliding plunger or piston, the suction of the engine on the plunger causing a greater or lesser opening of extra air inlets, so that as the speed of the engine increases the air inlet is greater to compensate for the increased suction put on the petrol jet. Now, when taking in air through these extra orifices, of course, whatever dust or other foreign matter is present in the air is taken in past the automatic piston, and, since moisture usually condenses about this part, the dust is there deposited. The effect of this is to cause the piston to stick or work erratically, this having a bad effect on the running of the engine, apart from increased gasoline consumption. Some automatic pistons are made so that they can be readily detached, so that in such a case all that it is necessary to do is to see that the piston is washed out pretty frequently, but in cases where such can not be done, it is a good plan to get a small squirt and wash the piston orifices thoroughly with a spray of gasoline, which does the job quite as well. Of course, in doing this care must be taken that no naked lights are in the vicinity of the carbureter, nor until the gasoline vapor is thoroughly removed must a lighted match be thrown on the floor.

Another frequent use of trouble with au-

tomatic carbureters is that due to the spring losing its tension or in other ways getting out of adjustment. There is usually a small nut or pair of nuts fitted, which can be screwed up or down to alter the tension or pressure on the piston controlling spring, and sometimes such nuts are rather likely to shake loose and alter their position relative to the stem on which they are screwed, thus altering the spring tension. These should be examined from time to time to assure the user that they are in the correct position. When the spring becomes too weak, either a new spring must be fitted or, as a temporary measure, the old spring can be removed and carefully stretched, and then replaced, the adjustment being made by means of the nuts, as before mentioned.

On a number of motor vehicles the foot brake lever and also the hand brake lever are connected to the clutch, so that on operating the foot brake or the hand brake the clutch is taken out of action. It is claimed that such a method is best for the novice, but we hardly think that such is really the case. It seems to us that with the flexible engines now fitted very little operation of the brakes should be required, as the whole control of the car, save in cases of extreme emergency, can be readily brought about by the operation of the throttle valve. A motorist who through his own fault has to quickly apply foot and hand brakes is one who should not drive a car, as evidently his judgment or ability is at fault. For instance, on descending long, steep hills the car can be held under control in most cases quite as readily by almost closing the throt-

tle and retarding the spark, but sometimes perhaps too great a speed will be attained by using the throttle and ignition solely. In such cases a slight application of the foot brake or the hand brake gives the extra check required; but if the application of one or other of these breaks disconnects the engine, one really good brake is gone, and the car immediately gets away on if the brakes are not absolutely in good order. It will be seen by dispensing with the inter-con-

nections (which can be readily done on many of the cars now fitted with them) that a really valuable and additional brake from the engine is obtained. The only really good point in favor of the hand-applied brake taking out the clutch is the one which has been put to us by a reader, and is that it is impossible to start off from rest with the hand brake on, simply because the clutch can not be let in at all without the brake is taken off.—*The Autocar.*

ALCOHOL AS A FUEL FOR MOTORS.*

(Concluded From Page 219, July Issue.)

So far it has been seen that alcohol is deficient in heat units; that in efficiency and explosive range it is ahead of its competitors; that the combustion is more complete than with other fuels, and in consequence the alcohol motor will not be troubled by sooty plugs or odorous exhausts. It is true that French cars said to burn alcohol produce a strong odor, but, as already stated, that is because the alcohol is mixed with a considerable proportion of gasoline or benzine. The German Government cars use a mixture of alcohol with ten per cent. of water and about two and a half per cent. of benzol, and it is impossible to detect any odor within three yards of the exhaust.

The efficiency of a gasoline engine depends largely upon the compression of the charge. The higher the compression the greater the efficiency. Now, while the compression of a charge of gasoline vapor is limited by the danger of pre-ignition, the alcohol engine can not be run satisfactorily at less than ten atmospheres (150 pounds) compression, and fifteen atmospheres will give much better results. The maximum compression for a gasoline motor may be placed at something like six atmospheres

Using gasoline or other fuel that splits up into lower hydrocarbons, soot deposits are bound to occur under some conditions, and this soot, remaining incandescent after the explosion, ignites the next incoming charges and causes what is known as pre-ignition. With alcohol, if the cylinder is polished and there are no protuberances to

get red-hot, the alcohol motor can be run on fifteen atmospheres without pre-ignition, as it will cause no deposit of soot. The starting of a large motor working at such high compression can easily be effected by mechanical means for reducing the compression while cranking—for instance, by fitting a special set of cams for the purpose.

One of the advantages of alcohol is that in case it becomes ignited it can be extinguished with water, either fresh or salt. Gasoline will float on top of water and continue to burn, and must be extinguished with sand or other solid substances, but alcohol will mix with water and has a certain affinity for it. Therefore, the mixture of water with alcohol will reduce its burning power, and when the dilution reaches something like fifty per cent. the alcohol will refuse to burn. In submarine vessels in which gasoline motors are used, the fumes of gasoline are greatly feared; alcohol would not give this trouble.

The greatest obstacle to the progress of alcohol motor development is the fact that in many countries the internal revenue on alcohol is so heavy as to practically prohibit its use as a motor fuel. There are many firms making alcohol motors in Germany, where alcohol is cheap, but in England alcohol is made under such heavy government restrictions that the price is prohibitive. Alcohol is regarded in the light of an extremely potent intoxicant, and its manufacture is accordingly restricted, but in Germany, France, Italy, Russia, Chili, Mexico, Brazil and other countries a more liberal view is being taken. Alcohol can be denaturized (rendered unfit for drinking) as soon as it is produced, but the British Government seems to overlook this fact.

*From a paper by Dr. Ormandy before the Western Section of the Scottish Automobile Club.

<p style="text-align: center;">PRODUCER GAS TESTS AT ST. LOUIS.</p>
--

The accompanying table is from the preliminary report of the tests of fuel at the St. Louis Exposition, made by the U. S. Geological Survey. Only the total coal per electrical H. P. per hour is given for the steam tests as a basis of comparison with the gas producer tests.

The report states that the steam generated by the boiler was used in a simple non-condensing engine of the Corliss type, whose water rate was 26.3 pounds of steam per hour per H. P. developed. This engine was belted to the electric generator, and the mechanical efficiency of this combination of engine and generator was 81 per cent. With these figures available it will be an easy matter to calculate the number of pounds of coal which would have been required to produce an electrical H. P., provided a more economical type of steam engine had been used, or if the electrical generator had been directly connected to the engine, with the resulting advantage of a higher mechanical efficiency. If, for example, the steam generated had been used by a steam engine capable of generating 1 H. P. with 18 pounds of steam per hour, and if the engine and generator had been direct connected, giving as high a mechanical efficiency as 90 per cent, then the total dry coal per electrical H. P. per hour would have been reduced from 4.3 pounds to very nearly 3 pounds. While these figures are frequently and easily obtained by steam engines operating in large units, it will be conceded that in plants of from 200 to 250 H. P. they are but seldom reached. It should be mentioned that the labor required would be the same for the operation of either the boiler plant or the gas producer plant of the capacity under test. In either plant two men would be sufficient.

The R. D. Wood & Co. 250 H. P. gas producer used was 8½ feet in external diameter, 15 feet high and was connected through an economizer, 3 feet in external diameter and 16 feet high, to a scrubber, whose external dimensions are 8 feet in diameter by 20 feet in height.

The report describes the method of operation as follows: The scrubber is filled with gas house coke, which is constantly flushed with water during the operation of the plant. From the scrubber the gas pass-

es to the tar extractor, a piece of apparatus whose detailed construction is carefully guarded by the manufacturers of the producer, but which resembles in outward appearance a centrifugal pump. The speed of rotation of this device is of vital importance in tar extraction. After passing through the tar extractor the gas goes directly to the purifier, an iron box 8 feet square and 3 feet 3 inches in height. This box is filled with oxidized iron filings and shavings that remove the sulphur from the gas, which next passes to the holder, a receiver a little over 20 feet in diameter and 13 feet high, of 4,000 cubic feet capacity. From the holder the gas is conducted through a meter of 1,000,000,000 cubic feet capacity to a three-cylinder vertical Westinghouse gas engine, with cylinders of 19 inches diameter and 22-inch stroke, rated at 235 B. H. P. The engine is in turn belted to a six-pole 175 kw. Westinghouse direct current generator. The load on the generator is controlled by, and the energy developed dissipated through, water rheostats.

The tests were begun on the basis of a total of 50 hours for each test. The plant was operated 10 hours a day and then fires were banked for the night, the records being continued the next morning. This permitted one test a week only. With the small crew at command, it seemed to be the best possible arrangement, and was continued for the first two tests. It was then thought desirable to secure double the number of tests, and the schedule was arranged to conduct two tests per week, each of 30 consecutive hours, allowing sufficient time between tests to make the necessary change of fuel and to enable the fuel bed in the producer to be brought to a proper working condition.

As it was desired to test as many coals as possible before the close of the exposition, the highest possible economy was made a secondary consideration, and for a part of the time the plant was run with a leaky hopper and other unfortunate conditions, which naturally impaired its efficiency. In comparing the results, it should be borne in mind that in these preliminary tests the object has been to demonstrate the possibility of using these coals in a producer, and not to show how efficiently they could be

burned. Although the results in many cases have been highly satisfactory, there is no question that in a second series of tests upon the same coals, made with the idea of showing the greatest economy, the amount of coal per H. P. per hour will, in the majority of cases, be much less.

During tests Nos. 5 to 14, inclusive, the hopper of the gas producer leaked, and considerable gas was wasted, thus vitiating to a small but determined extent the efficiency results that might otherwise be shown for the coals tested during that period. But at the time of making these tests it was not

practicable to stop the operations of the plant for repairs, and the main purpose of the preliminary tests being to determine whether the coals were suitable for producer gas purposes, it was decided to proceed, in spite of the leak in the hopper, and to repeat later, under more favorable conditions, the tests for relative efficiency.

The results show with what ease gas may be produced from bituminous coal and lignites, and, taken as a whole, indicate the satisfactory economic results that may be expected under ordinary working conditions.

Summary of the results of the coal tests made under the boiler and in the gas producer.

Name of Sample	Hours of Trial	Pounds Dry Coal consumed per Hr.*		Pounds Dry Coal burned per sq. ft. of grate surface per Hr.†		B. T. U. per pound of dry coal used.		Electrical H. P. delivered to switch-board.		Pounds Dry Coal per Electrical H. P.‡	
		Gas Pro.	Gas Pro.	Gas Pro.	Gas Pro.	Gas Pro.	Gas Pro.	Gas Pro.	Steam	Gas Pro.	Gas Pro.
Alabama No. 2...	43.00		328.7	7.78	13,365	200.6	4.08			1.64	
Colorado No. 1...	30.00		341.7	7.56	12,245	200.2	4.84			1.71	
Illinois No. 3....	30.00		356.7	8.41	13,041	199.6	4.34			1.79	
Illinois No. 4....	30.00		348.5	7.96	12,834	198.4	4.80			1.76	
Indiana No. 1....	29.67		384.3	9.08	13,037	199.9	4.13			1.93	
Indiana No. 2....	7.00		312.0	7.13	12,953	201.0	4.35			1.55	
Indian Ter. No. 1.	31.00		374.0	8.95	13,455	204.0	4.04			1.83	
Kentucky No. 3..	30.00		381.2	8.92	13,226	200.5	4.22			1.91	
Missouri No. 2...	4.33		439.6	7.96	11,882	198.6	4.93			1.71	
W. Virginia No. 1	24.00		315.6	7.36	14,396	200.4	3.90			1.57	
W. Virginia No. 4	9.00		258.2	5.96	14,202	199.7	3.62			1.29	
W. Virginia No. 9	6.33		320.1	7.60	14,590	201.0	3.46			1.59	
W. Virginia No. 12	30.00		300.5	6.92	14,325	199.8	3.53			1.50	
Wyo. No. 2 (Bit).	30.00		416.5	9.50	10,656	201.2	5.90			2.07	

*This includes the coal consumed in the producer and the coal equivalent of the steam used in operating the producer.

†Coal actually consumed in producer only.

‡Gas-producer hopper leaked during these tests.

BOOK REVIEWS.

Motors and Motoring, by Henry J. Spooner, C. E., 99 pages, 4¾ x 7, cloth 50c; postage 8c extra.

This book is intended for the man who knows little or nothing about a gasoline engine or gasoline car. The author aims to instruct the reader on the rudiments of gasoline engines and automobiles, not overlooking the fact that it would be impossible to cover all points ever in a volume much larger than this one. The man who is in the position of desiring to learn some of the elementary points before beginning or undertaking to operate an automobile will find the book well worth reading.

It is very well printed on good paper.

The twenty illustrations are diagrammatic and intended to be simple and easily understood. It is to be regretted that the spelling "gasolene" is used, especially as it is not used in every case where the word occurs in the book. There are signs of the author being more familiar with English cars than American, which is confirmed by the evidently inadvertent use of the word "petrol" in one place. We can not say that the copious use of footnotes, explanatory of the text, adds anything to the continuity of idea in reading, but, as before stated, the novice will find many simple explanations of construction and operation which will do much to assist him.

MOTOR BOAT FALLACIES.

Salt water for cooling purposes is in great abundance, says a correspondent of a marine paper. It is my belief, however, that he should have said: "Salt water for trouble." The Gregory, on its trip across the Atlantic, while performing in a very creditable manner, all things considered, was very seriously handicapped because of salt precipitation.

It seems that salt water gives but little trouble under ordinary conditions, considering intermittent service and the usual run of small motors; but in the case of the Gregory, in which the motors were, of course, operating continuously, probably at or near full load, new conditions and new troubles were experienced, and the saline deposit was found to be serious, since the salt actually precipitated was enough to clog up the passage ways.

Some years ago the writer experienced substantially the same trouble in connection with the operation of some 12 inch by 12 inch four-cylinder motors, in which the deposit within a week was so great that the water jackets had to be re-designed with a view to removing this troublesome de-

posit at intervals. It is generally well understood that a deposit of any sort is very detrimental to the efficiency of the heat transfer through the intervening walls, so very detrimental, in fact, that a very thinly deposited skin of any foreign substance will practically make the motor valueless.

One way to eliminate much of this trouble is to employ very large exhaust openings, with a view to conducting away as much as possible of the products of combustion as quickly as may be, thus reducing the duty of the water jacket to a minimum; but it is perfectly obvious to even a casual observer that by no possible means now known to designers can the water jacket be dispensed with entirely when dealing with high-powered motors.

Air cooling is, of course, feasible when reference is had to motors in which the cylinders are under five inches in diameter and exposed to a very considerable air current, but air cooling, within the knowledge of designers, is not feasible in marine work of any magnitude, if, indeed, marine service lends itself to air cooling at all.—*The Motor Boat.*

THE STEAM TURBINE AND THE GAS ENGINE.

Henry D. Jackson discusses the steam turbine and the gas engine as follows in a recent issue of *The Engineer*:

The claims made by turbine manufacturers are that the turbine is superior to the reciprocating engine in the following ways:

1. Simplicity (?).
2. Economy in coal consumption.
3. Lower cost of operation and maintenance (?).
4. Less floor space required (granted).
5. Lower initial cost (when entire plant is taken into consideration).
6. High efficiency over wide ranges of load (?).

Some of these points no doubt are true in fairly large sizes, but many of them remain to be proved. As far as coal consumption is concerned, I am by no means sure that the claim is true. The tests that have been quoted do not give the necessary data in order to make any comparison. For the past two years I have been asking for

light on this matter, by requesting that tests be reported so that comparison may be made on the heat unit basis. Then the boilers do not enter into the engine test, and in this way we do not go back to the coal pile, as we must do when results are given in coal per H. P., or to steam consumption, when results are given in pounds of steam per H. P.

If the turbine manufacturer is to make such claims for coal economy and obtain purchasers on this basis, then the gas engine should run it out of the market when results are taken on the same basis. As a matter of fact, however, the purchaser looks further when buying a gas engine, and should, also when buying a turbine.

Lower cost of operation and maintenance has yet to be proved. Turbines have not been in existence long enough to warrant making any statements, but if the entire

plant is taken into consideration, as it should be, lower cost would seem doubtful, for, as you stated concerning the condensing system, the cost of maintenance is high, and when the superheater is taken into consideration there is another costly item.

As regards the last item, the turbine has been beaten by reciprocating engines at all loads, and unless great care is taken in the installation of the auxiliaries, the steam consumption is greater at light loads, when the latter are taken into consideration. Plants have been known where the steam used by the pumps, etc., at light load on the turbine, has been greater than in the turbine itself.

It is unfortunate for the purchaser of prime movers that the turbine came in before the gas engine was but half thoroughly tried out, for the turbine was apparently so simple, and has been pushed so persistently by the manufacturers, that the gas engine has taken a back seat temporarily. This condition is likely to obtain until people wake up to the fact that the gas engine has not been given a fair trial. When the user of the gas engine will take half the care of the producer that he does of a boiler, two-thirds of the troubles will disappear. Instead, he

looks for a heat economy about double that of a steam engine, and at the same time less work on the engines and producers. Thus he is looking for a double reduction in the operating expense. He also asks that the producer be continuous in action, a thing he would never ask for in a boiler, and, because he can not get it, condemns the entire apparatus. Is this a square deal?

Gas engine plants should be installed the same as steam plants. The producers should be in duplicate, so that one could be shut down for cleaning when the other is in operation, and the gas thoroughly cleaned before entering the engine. A considerable increase in the cost of the gas apparatus is warranted with a gas engine plant, for the reduction in the fuel warrants it.

The coal bill in about 75 per cent of the gas engine stations is 50 per cent of the cost of the operation of the station, and in the remaining 25 per cent the coal bill is over 60 per cent of the total cost. Is it not worth while to spend the value of 10 to 15 per cent of the coal bill to save the remaining 25 or 20 per cent, on the basis that a gas engine would use 60 per cent of the coal required by a steam plant?

THE GORDON-BENNETT RACE.

To win the coveted Gordon-Bennett race two successive years has been the desire of every winner in previous years. But Thery, last year's winner, was the first to succeed, and by his success in this year's race he enables France to keep the trophy for 1905. Italy, in winning both second and third places, comes to the front with her Fiat cars, while Thery's car—the Richard-Brazier—finished fourth. England's best man, Earp, came fifth. Germany was in still worse luck and America was as far from

winning, her one representative to finish being twelfth.

The winning car was equipped with a 90 H. P. engine, while the two Fiats had 120 H. P. each. This seems to confirm the statement made by many that in such races as these the highest powered car has not necessarily the best chance to win, for careful driving, freedom from tire and other troubles are the things that make for time, over and above a certain rate of speed. In this respect America had a chance to win.

MOTOR-PROPELLED CANAL BOATS.

A test of gasoline and petroleum propelled canal boats at Lockland, O., late in June was successful in every way, and officers of the Ohio Boat Company are greatly pleased with the result. The two boats, the Dayton, propelled by gasoline, and the Middletown, propelled by petroleum engines, made the six-mile trip on the canal in one hour and fifteen minutes. Both boats

were together during the entire distance. Fifty representative business men were present and made the trip on the boats. The Ohio Boat Company plans a regular schedule between Cincinnati and Dayton as soon as the canal can be opened. As soon as the aqueduct at Carthage is finished the company will operate boats between Cincinnati and Hamilton.

WOOD GAS FOR POWER.

In our issue of February, 1904, we described a gas producer plant at the works of the Montezuma Copper Company, Nacozari, Sonora, Mexico. In a paper head before the British Institution of Mining and Metallurgy, Mr. G. M. Douglass gave some additional information relative to the method of operation of this plant. Wood fuel, known as black oak, is used. It reaches the plant in 3 feet 6 inch lengths, which are sawed in two. In starting, coke is put on the grates of the generators to a depth of 3 feet to 3 feet 6 inches. Less than three feet is not advisable when making gas from wood; otherwise volatile products of distillation from the fuel may pass through un-fixed, and by condensing to soot or tar may result in waste and cause trouble by dirt. Small and light wood, tops of trees, branches etc., should be put on coke to a depth of about 3 feet and the blower started. A handful of lighted oil waste thrown on top of the wood will start fires. The light wood is enough to make a coke bed incandescent, and usually requires about an hour. As soon as this is seen to be the case fast feeding with heavy wood is necessary. The heavy lumps, which are objectionable when fires become older, are well saved for this purpose. The fires should be kept at a low temperature, which may be regulated by the speed of feeding. Only enough combustion is required to transform the wood into charcoal. When a bed of this incandescent charcoal and partly consumed wood is formed to a depth of a couple of feet above the coke bed the fires are ready for supplying gas to the engines. The valve to the suction of the exhauster should be opened, the fan stopped and its suction valve closed. This preliminary operation usually requires from four to five hours and from three and one-half to four tons of wood.

Burning wood at the rate of 30,000 pounds per day, the ash accumulates so that by the fifth day's run on one set of plant it is necessary to shut down to clean, a change being made to the other set. For the first 36 hours the fires are allowed to rise—i. e., more wood should be put in than is consumed to ash. This becomes charcoal and adds steadiness to the value of the gas. There is no ultimate loss, all fuel in the

generators being recovered before shutting down to clean. The wood should not be longer than two feet. Heavy pieces are very objectionable and should be split. The fire should be fed steadily, and with a little fuel at a time. The judicious use of different sizes of wood must be made by attendants to keep the surface of the fires level and ensure the even passage of gases through them.

The gas has a calorific value of about 135 B. T. U. per cubic foot. No trouble is experienced with pre-ignition, though the proportion of hydrogen in wood gas occasionally runs up to 23 per cent, and the compression of the engines is as high as 90 pounds, with pistons uncooled by water.

A trial was made on one set of generators for a run, in which the greatest care was taken to ensure accurate figures. Fires were lighted in the set of generators, and the trial was made at 9:30 a.m. on December 26, 1904. At 3 p.m. they were ready to run on, and the old fires were discontinued altogether at 7 p.m. At 2 p.m. on December 31, after 4 days and 23 hours' run, a change was made again, and the trial completed. The results are given in the accompanying table:

Coke put into generators.....lbs.	8,590
Wood used for firing up.....lbs.	7,400
Duration of run.....hours.	119
Ash taken from generators.....lbs.	14,134
Coke recovered.....lbs.	2,572
Total amount of wood used.....lbs.	138,840
Total amount of coke used.....lbs.	8,918
Total amount of combustible used.....lbs.	144,758
Water in wood.....per cent.	19.8
Ash in wood.....per cent.	10.8
Calorific value of gas B. T. U. actual (average of 35 tests).....per cent.	116.4
Total output of power house.....kw. hours.	39,700
Total output of power house, H. P. hours.	53,217
Average power.....electric H. P.	447.2
Consumption per electric H. P. hours:	
Wood.....lbs.	2.6
Coke.....lbs.	0.11

We learn that England has finally followed the initiation of this paper, and there has been established a gas engine publication to be known as *The Gas and Oil Engine Record*. As yet the first copies have not yet been received, but we extend our cordial good wishes to our English contemporary, which is to be edited by Mr. W. A. Tookey, the author of several English books on the subject of gas engines and gas producers.

ITEMS.

A gas engine is to an industry what bread is to life—the staff.—*Gas News.*

The John W. Swan Company, Lima, O., has changed its name to the Lima Gas Engine Company.

The modern gasoline engine is turning many a retail lumber dealer into a machine woodworker.—*The Woodworker.*

Dixon's American graphite pencils were the subject of a July calendar and blotter, which showed a Fourth of July effect.

The Michigan Motor Company, Grand Rapids, Mich., has issued a special catalogue C of propeller wheels of various types.

According to their count about the middle of May, Fairbanks, Morse & Co. say that there were 35,000 of their engines out.

Dobbie-McIrnes, Ltd., 45 Bothwell street, Glasgow, Scotland, send us a new catalogue showing several designs of gas engine indicators, continuous recorders, etc.

The Armstrong Bros. Tool Company, Chicago, Ill., manufacturers of tool holders, have removed to a new plant at 104 to 124 North Francisco avenue, between Carroll avenue and the C. & N. W. Ry.

"It's a Peach" is the significance of a monthly calendar which is being sent out by the Advance Manufacturing Company, Hamilton, O. The Hamilton Advance engine is shown, and on the background is a peach.

Termaat & Morahan Company, Oshkosh, Wis., are sending out a catalogue of their two and four-cycle marine engines. A very interesting page is the last one, which contains some excellent suggestions on operating a gasoline engine.

The Venezuelan Government has been so impressed with the possibilities in the use of alcohol motors, lamps, etc., that for two years the imposts and duties heretofore applicable to alcohol, alcohol motors and other alcohol devices will be abolished.

An esteemed English contemporary recently showed a method of ignition under the head of "A New Ignition Device," and we recognized the method as that which has been used on Foss engines for many years.

On reading the description we noticed the method was credited to the "Foss" (American) engine. While the error in name may have been typographical, we would call the editor's attention to the fact that the method of ignition used on these engines is not new in this country, but has been in use for a good many years.

The Gas Engine Supply Company, of Newport, Ky., report an excellent business in the spark coil, spark plug and accessory lines. The company is old in the gas engine line and understands the requirements of this line of work.

The Steurteman National Invention and Manufacturing Company, St. Louis, Mo., will start a factory September 1 for the manufacture of gas and gasoline engines for all purposes. The engines will be single and multiple cylinders; automobile and motor trucks will be included in the product, as well as gasoline-propelled railway cars.

The S. Obermayer Company, manufacturers of foundry facings and supplies, of Cincinnati, Chicago and Pittsburg, announce they have opened an office at 120 Liberty street, New York. Mr. Edgar Seaman, who has represented the company at Pittsburg for some past years, has charge of the New York office.

The Buckeye Manufacturing Company, Anderson, Ind., in announcing the "Lambert" gasoline automobile, have issued a well-printed catalogue showing some of their special features. Among these may be mentioned the Lambert friction transmission. The motor fly wheel is of the disc type, the face covered with a patent metal composition. The friction wheel is applied to this disc plate by means of a foot ratchet.

"Wear" is the real sub-title of a booklet "Some Reasons Why" just issued by the Otto Gas Engine Works, Philadelphia, Pa. The booklet is very artistic and contains illustrations showing many of the parts of the Otto engine. Attention is called to the fact that wear is bound to occur in various parts, no matter how well built a machine is, and the booklet endeavors to show reasons why the Otto engine will not only wear less of all engines, but why repairs may be secured promptly at the least expense.

THE GAS ENGINE.

STATIONARY—AUTOMOBILE—MARINE.

PUBLISHED MONTHLY BY

The Gas Engine Publishing Co.

Blymyer Building, Cincinnati, Ohio.

ADVERTISING RATES ON APPLICATION. Address All Communications to the Company.

Entered at the Postoffice at Cincinnati, Ohio, as Second Class Matter Feb. 20, 1899.

VOL. VII

SEPTEMBER, 1905.

No. 9.

Domestic Subscriptions, \$1.00 per Annum.

Single Copies, 10 cents.

Foreign, \$1.50 per Annum.

In our last issue appeared an article on "Motor Boat Fallacies," in which it was stated that the *Gregory* suffered troubles from a saline deposit in the water jackets. The author of the article has since learned that this was not the case, although he had previously been informed that such difficulties had been encountered.

We are presenting in this issue some reproductions of efforts made by two of the large gas companies of the country to induce power users to install gas engines. So many of the gas companies fail to realize the importance of developing this field for gas that it is interesting to learn what some of the more progressive gas companies are doing. One of the companies referred to is in the East, the other is in the West; but the methods of each might profitably be employed in any section of the country.

There is no accounting for the conclusion reached by experiences of different persons along the same line. This was impressed on our mind recently during conversations we had with two different gas engine designers. Said one, after explaining some ideas he had in regard to exhaust from a four-cycle engine: "But as I'm not going to have anything more to do with four-cycle engines, I dropped that idea. The two-cycle is the only thing I will have anything to do with in the future." Another one said: "I'm through with the two-cycle; I've had all the trouble I want, and am going to stick to the four-cycle in the future."

Accidents are often the cause of the development of great inventions, and are more often the turning points in the careers of men. Quite recently a gas engine manufacturer was out in a boat which was equipped with a gasoline en-

gine with the jump spark. His own engines use the make-and-break. The boat accidentally got swamped with water, and when the engine manufacturer looked at the engine, expecting that the water which had flooded it would have caused it to cease ignition, he was surprised to find that such was not the case. "I doubt if my make-and-break igniter would have stood that test," he said. What he is thinking about doing is to adopt the jump spark. A similar accident happened to a motor boat enthusiast, and resulted in the boat capsizing because the engine could not be started. The owner was very nearly drowned, but escaped and spent the greater portion of his time for a year in perfecting a new type of spark plug which he is just bringing on to the market now.

In the preparation of a catalogue, too much care can not be given to prevent statements being misunderstood, as well as to enable the lay reader to understand properly technical or semi-technical matter. The average manufacturer knows all about his engine, but fails to bear in mind the fact that most of the readers of his catalogue do not know it so thoroughly. In preparing such a catalogue much better results would often be secured if the writer of the descriptive matter kept in mind the fact that he must write for the man who may know nothing whatever of any gas engine, let alone this particular make. As for the prevention of misunderstandings, this is as important as the creation of a correct understanding. An illustration of poor catalogue writing recently came to our attention in the following statement taken from a battery catalogue: "System No. 1 is not very economical, as about 35 per cent of the energy of the charging current must be wasted." With-

out going into further detail and explaining that this is not a low efficiency for the type of installation, a wrong impression is given, and the reader at once decides he does not want such an outfit. A presentation of the counter advantages of such a system should be made in such cases as this.

As will be found mentioned in another column, the United States Department of Agriculture has now a bureau to make investigations of the relative advantages of farm power and implements. The work of this bureau should be of exceeding great value to the farmers of the country, and also to the manufacturers of gas engines for agricultural service. Not only

will the farmers become familiarized through an unprejudiced source, with the advantages of using gas and gasoline engines, but the manufacturers will be able to learn some of the special requirements to be met, the advantages of certain methods as shown by the tests made, and they will also receive the benefit of being able to present to possible purchasers the results of tests from disinterested sources. Altogether, this bureau should be able to make itself of great value to the two great interests affected—the farmer and the gas engine manufacturer. And from what we know of Prof. Zintheo, who is at the head of the department, we feel confident that he will be able to accomplish these results.

THE REASONING GAS ENGINE OPERATOR.

BY ALBERT STRITMATTER.

"Now, gentlemen, the engine may not start the first time I try it. In the morning I can always start it on the first attempt, but it has been running a while and gotten warmed up and I may not get the mixture just right the first time."

To many unthinking persons such an explanation by a gas engine expert would appear to be an admission that there was something the matter with the engine and that the operator knew he couldn't start the engine the first time he tried, and was trying to smooth it over before he made an attempt and failed. But his explanation showed that he was in reality a reasoning gas engine operator, he had studied the method of operation of his engine and knew what condition would have to be fulfilled before the engine would start.

Many an unreasoning gas engine operator has been asked by a prospective purchaser of an engine to stop his engine and show him how he started it and how quickly it could be done. Being only too glad to show how easily he could do it, the operator has shut the engine down and on attempting to start it again in a minute or two has been chagrined at the first failure in months to start on the first trial, or even after repeated trials. The trouble has been due to the fact that he did not thoroughly understand the conditions to be met in starting the engine. And yet they are exceedingly simple in nature.

In starting all ordinary sizes of gas or gasoline engines, the usual process is to take a squirt can and squirt a little gasoline into the cylinder to furnish the fuel for the priming or initial charge. With gas engines some operators avoid this by turning the gas on slowly and learning by experience just how to do it and just when to go through the operations of starting. With small engines it is often the case that the operator will turn the engine over several turns, until it draws in its own charge and starts itself. In any case, it is necessary to draw into the cylinder a quantity of the fuel, together with a certain proportion of air, forming a mixture which will ignite and explode. If the quantity of either fuel or air is too great, or too little, the mixture may not ignite and trouble in starting is experienced.

When the gasoline is drawn into the cylinder it is essential that more or less of it be atomized or vaporized, so as to mix with the air instead of collecting in liquid form at the bottom of the cylinder. Unless enough of the gasoline mixes with the air to make an explosive mixture, the engine will not start, even though there may be sufficient liquid fuel in the bottom of the cylinder. This mixing is accomplished usually by the sucking of the gasoline into the cylinder slowly, giving it a chance to vaporize.

When the engine is first installed the operator learns by practice that he must use

a certain amount of gasoline to give this result. In all probability he uses an excess of fuel, because the engine is cold when starting in the morning, and not all of the priming charge vaporizes.

This condition continues until some day he shuts down the engine after it has been running for a time, and then he attempts to start it while the engine is still hot. Not reasoning that the conditions are different from those existing in the morning, he goes through the usual process, and meets with his first failure in months in starting the engine. His astonishment is only equalled by his failure to understand the cause.

If he has the faculty of reasoning where-in the engine conditions are different from usual, he will soon realize that as the engine cylinder is warm from its previous running, it easily vaporizes the entire quantity of gasoline used for a priming charge and this gives a mixture so rich in gasoline that it fails to ignite at all and the engine will not start. His remedy is to open the relief cocks and turn the engine over idle for two or three revolutions to clean out the cylinder, then start with a fresh priming charge, but one of much less than the usual size. Not having much experience in determining what quantity is required under the circumstances, he may not hit the right quantity, without one or two trials.

The expert quoted in the opening paragraph of this article realized just this condition of affairs, and knew that while he could start the cold engine the first time, he could not always gauge the correct quantity for an engine which had been running until

it was well heated up. And yet, this is easily done by any operator who has occasion to do it once in a while and who thereby learns the right quantity of priming charge to use.

In a small machine shop the writer recently noticed almost any of the men who needed power for a few minutes would go to the engine and start it on the first attempt, and then the engine would be shut down till the next man needed power. The proprietor of the shop, after showing some of the work they were doing, volunteered to start the engine on the first trial and did so, just as his men had been doing every few minutes. These men had acquired the knack of gauging the priming charge under such circumstances.

As was referred to in the first of this series of articles several months ago, the reverse of this condition of starting calls for the use of reasoning on the part of the operator. During the hot weather the operator finds that it is not necessary to use a large priming charge, as the fuel vaporizes readily, even when starting the engine in the morning. But toward the last of September, and more particularly later on, the weather gets cool enough that the fuel does not vaporize readily, and some extra cold morning the engine may not start until the operator reasons out the conditions and uses an extra large priming charge, so that there will be sure to be enough gasoline vaporized to make an explosion possible. A good, strong battery will help matters, for a large, hot spark is more certain than with a half exhausted battery.

THE GASOLINE ENGINE AND THE CIRCUS.

In a recent issue we illustrated a portable cleaning and compressing outfit, operated by a gasoline engine and used by a large circus. Several months ago a gentleman connected with a carnival company talked with a representative of THE GAS ENGINE regarding the advisability of using a gasoline engine for generating electric light and power current in connection with the show, thereby eliminating all trouble with local electric light companies, who were often inclined to exact a high price for the service rendered. The amusement company was the Gaskill Carnival Company. In March they purchased two 32 H. P. port-

able Fairbanks - Morse gasoline engines, which were fitted with a throttling governor. These operate two 20 kw. dynamos. This plant furnishes current for 500 16 c. p. incandescent lights and 900, 8 c. p. lights, in addition to several arc lights. Since the first of May, when the season opened, there has not been a dollar lost by reason of failure to have lights, nor has there been any delay, except on one occasion, when ten minutes were lost by reason of not having gasoline. The plants are taken all over the country, and early in July were in Denver, where the manager of the show expected to have some difficulty. None was experienced.

THE DESIGNER SHOWN IN HIS ENGINE.

BY A. A. ANDREWS.

A writer in the *American Machinist* recently said:

"After reading some of the Sherlock Holmes stories, I often wonder if a man versed in machine tool construction could not make equally shrewd deductions as the designers of certain tools. A man can hardly fail to put something of himself into his work. We can read something of his generosity in the breadth of bearings and weight of parts; sizes of fillets and rounded edges give us an indication as to how easily he pushes his way through the world, while a tendency to square edges and pointed corners leads us to suspect that his elbows have a tendency to get in other people's way."

This led me to a train of thought about some gas engines I have seen and some of their designers. I finally came to the conclusion that gas engines, of necessity, represent the natures of their makers (designers and manufacturers), and are truly children of the men who are responsible for their existence.

For instance, some years ago I had an opportunity of going through a certain gas engine factory. I was surprised to see the various styles of engines in course of construction there. I could see not only the usual styles of vertical and horizontal engines, but there were two-cycles and four-cycles, hit-and-miss and throttling engines, single and multi-cylinder engines, engines which combined these various features in an almost bewildering confusion. You could get any combination you wanted, and it called to mind the exclamation of a United States Senator who, after having had a talk with a young man who agreed to everything that was said, and seemed to have no original ideas of his own, blurted out: "Young man, you are so terribly agreeable that you're disagreeable." It seemed to me that the man who was responsible for the line of engines gotten out by that company was so anxious to please every possible purchaser of an engine that he had lost all of his own originality (if he ever had any), and the result was he had a conglomeration of engines, none of which had any particularly striking fea-

tures. I am glad to say that since I was there the company has changed its scheme and seems now to be confining itself to one or two types, which have indeed some original features. I doubt not but that they are making much more money

Another engine of which I knew is the product of three men, one the salesman, another the designer and the third the foreman of the shop where it was built. Each has left his impress on that engine, and the man who knows the three can easily see it. But of the three, the foreman has left the most marked impression, his quick, thorough and accurate way of handling men showing in the short cuts in machine work, the strength of the parts, the quickness of their movement and the thoroughness of the adjustment.

A certain gas engine company at one time had as manager a man who had been with the company in other positions for years. He was known as a very conservative man, a feature which made him invaluable as a check against the too liberal tendencies of others. But when he was placed in the position of managing the company his conservatism resulted in the engine standing where it was. Practically no improvements have been made since then, and in the course of time the engine will no doubt be considerably antiquated.

About a year ago I learned of a case where the superintendent of a gas engine factory was so certain of his machinists that the engines were not assembled complete at the shop, but were sent out for assembly and erection where they were to be installed. Of course, none of the engines were ever run or tested before shipment, and it is surprising that any of them ran after erection. As it was, there was much trouble with them and the president of the company, who vouched for the truth of the statement that the engines had not been assembled, told me that he had found it necessary to insist on the superintendent assembling and testing every engine before shipment. Needless to say the characteristics of this man were shown in the engines which he sent out.

G A S N E W S .

We have on previous occasions mentioned the work done by the Public Service Corporation, of Newark, N. J., in pushing the sale of gas engines in the territory served by it. *Gas News* is the title of a booklet "published once in a while" by the gas department of the Public Service Corporation. It usually has about twelve pages, and the page size is four and one-half by nine inches. While not devoted exclusively to the gas engine department, considerable space is utilized in showing how gas engines are used in various kinds of factories.

The following are extracts from *Gas News*, and give an idea of the kind of matter published in this most interesting booklet:

"Some manufacturers labor under the impression that whatever may be the merits of a gas engine, it does not apply to their particular line of business because their shop conditions are just a little different from those of thousands of other manufacturers. To such we have this to say, that if they will

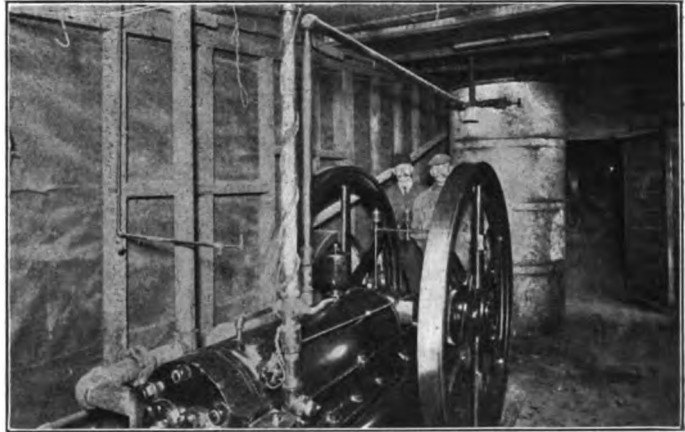

IN A CATTLE FOOD FACTORY.

only talk with manufacturers who are at present using gas engines to advantage, they will readily become convinced that it is a modern form of power and that they can effect a saving by such an installation.

"Upon this page two views are shown of gas engines operating silk machines in two of Paterson's prominent mills. Such installations demonstrate the reliability of gas engine power, as in such delicate operations as the manufacture of silk a steady power

is absolutely necessary. The engines represented are of the Backus type. One was taken in the engine room of the Winchester Silk Company, Albion avenue, and the other in the plant of the George W. Mains Silk Company.

"It will be noted that *Gas News*, from month to month, does not deal with experimental installations of gas engines and industrial gas appliances, but gives views of installations that are in actual and successful operation. Almost every kind of manufacturing is represented, and the seeker after reliable information as to the economy and efficiency of gas appliances has but to refer to the hundreds of factories using Public Service gas.

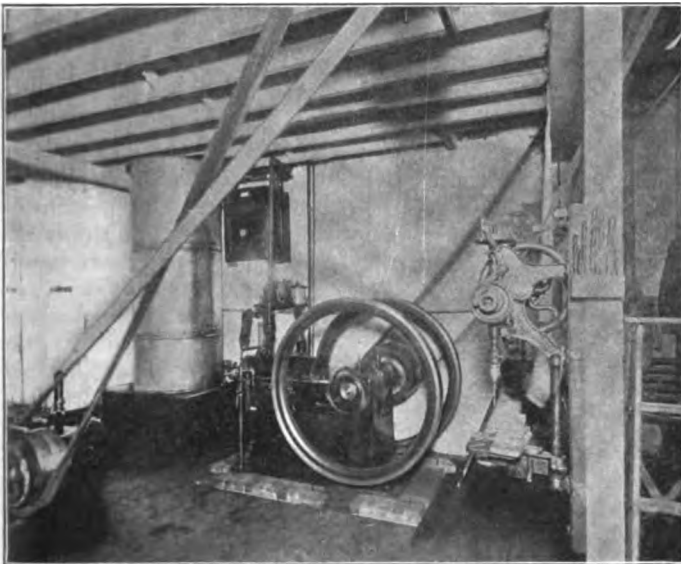

GEO. W. MAINS' SILK CO., PATERSON.

"Everything in the wood working line that is necessary in the building of a house is made in the carpenter shop of Elmer Zabriski, Madison and Fourteenth avenues, Paterson.

"Gas plays a big part in this work. An 18 H. P. gas engine runs nine machines that are in constant use. These machines are moulder, surface planer, jointer, rip saw, band saw, tendon machine, mortiser, sash machine and jig saw.

"Fifty horse power is required to drive the large machines in the plant of A. L. Clements & Co., No. 194 Eleventh avenue, Jersey City. This power is supplied by two gas engines—a 30 H. P. White and Middleton and a 20 H. P. Backus. These engines are connected to the same line shaft and run in unison. When the load is light only one of the engines is operated. The engines drive grinders, mixing machines and mills in the preparation of an all meal cattle food which has achieved a National reputation for the fattening of cattle.

"Wagon building and wheel wright work are the specialties of F. Kukeilski, No. 133 Stueben street, Jersey City. In this shop the efficiency of gas is demonstrated. The blower for forges, planers, etc., are run with a 10 H. P. White and Middleton gas engine.

"Kirschbaum & Co., Nutley, N. J., have built up an extensive trade in the small specialty line. They make manicure sets, surgical instruments, shoe horns, knife erasers, etc. Public Service was recently called upon to instal a gas engine to replace a gasoline engine which had been furnishing power. The change has proved gratifying to the firm, and they are strong advocates of Public Service gas. The engine is a 7½ H. P. and whirls away with but little attention. All of the tools manufactured are tempered and for that purpose a No. 16 American Gas tempering furnace is being operated with most satisfactory results.

"Thomas Wright, No. 71 Colden street, Jersey City, N. J., manufactures a special coal dumping truck. This work requires a number of heavy wood working machines,

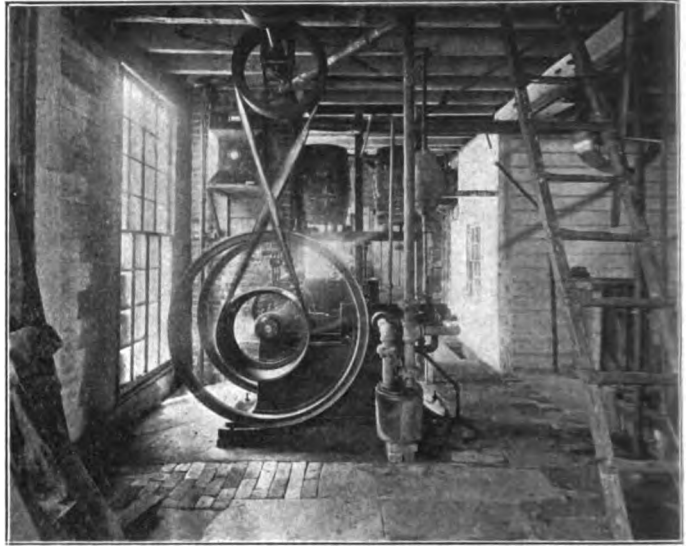

WINCHESTER SILK CO., PATERSON.

and these are operated by a 20 H. P. White and Middleton gas engine."

"Red and blue bandannas, piled in high, but orderly, profusion everywhere—where are they all going and where did they all come from?

"Undoubtedly they began their journey in some cotton mill, where they were woven into a dull gray cloth; from thence they were shipped to the Eureka Print Works, in Athenia, N. J.

"From this factory the dull colored material emerged, like the chrysalis from the cocoon, into a brilliant red or deep blue printed in pretty white patterns. In this new form it finally reached the Davies & Catterall Handkerchief factory, Passaic, N. J.

"Here yards of unmade handkerchiefs are cut and hemmed, thus becoming individual bandannas. The hemming process is in the hands of many women, who guide the handkerchiefs through sewing machines operated by a 12 H. P. gas engine. Each machine has a capacity of 2,200 stitches a minute, and, as the sewers are paid by the piece, the machines are usually run at their utmost speed.

"It is three years since the company installed their 12½ H. P. gas engine. During that time it has run forty-five machines for about eleven hours of every working day, and the total expense for repairs in those thirty-six months has amounted to but \$3, invested in a new rubber bag."

"GAS FOR POWER."

This should be the slogan of many of the artificial gas companies who have so far failed to interest themselves in the installation of gas engines. Many of these companies are continually drumming into the ears of the citizens of their towns that "Gas for heat and light" is the best thing, but "Gas for power" has been somewhat overlooked. It is refreshing to the believer in the gas engine to find exceptions to these cases, and when we noticed the accompanying advertisement in one of the Chicago newspapers recently we knew that the People's Gas Light and

Coke Company were doing good work in pushing gas for power.

This gas company has a gas engine department, at the head of which is a trained gas engine salesman. Being interested in having gas engines installed, the gas company has conducted tests of various makes of engines and is prepared to explain to possible users of gas power the advantages of gas engines, the cost of operation, and to show various makes in operation in different kinds of service. Solicitors hunt out possible users of gas engines and endeavor to interest them in

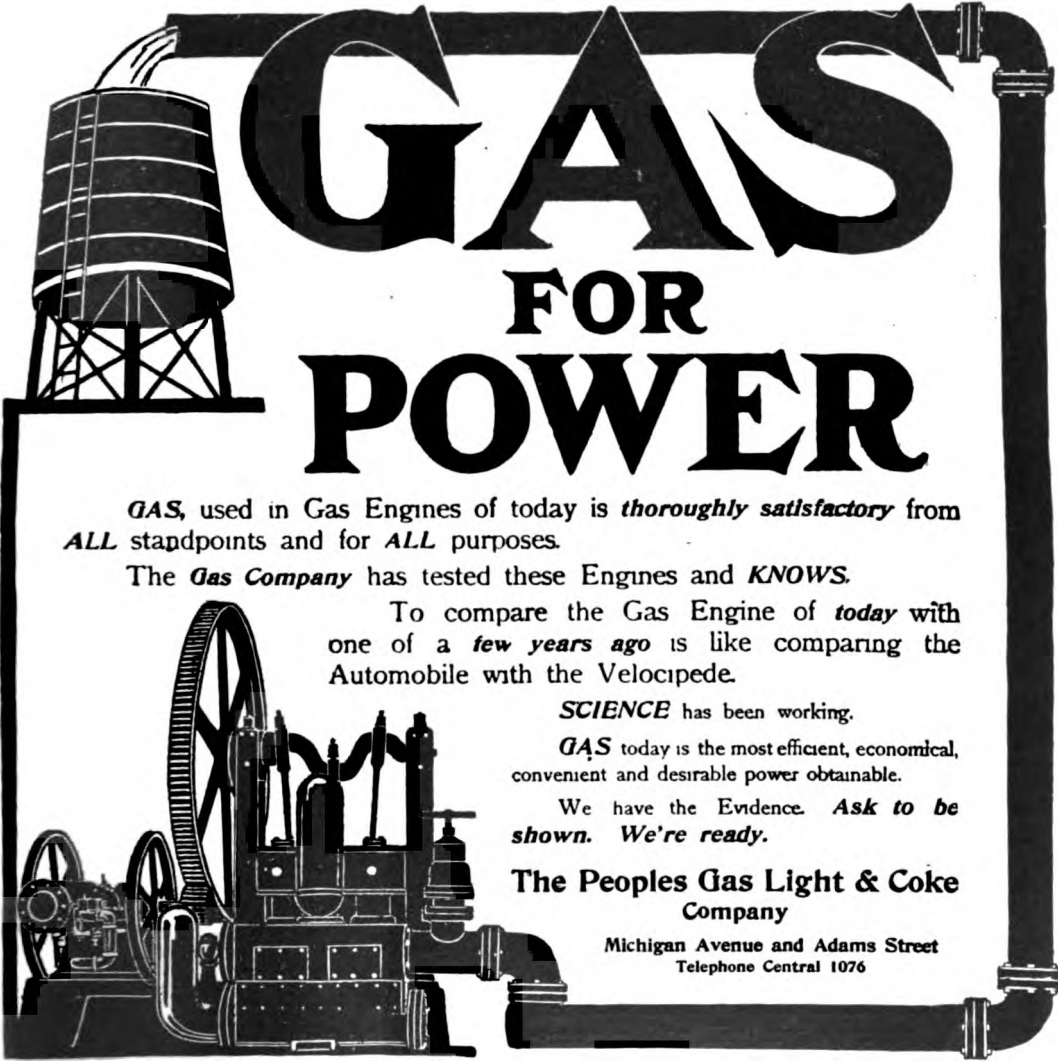

GAS FOR POWER

GAS, used in Gas Engines of today is *thoroughly satisfactory* from *ALL* standpoints and for *ALL* purposes.

The *Gas Company* has tested these Engines and *KNOWS*.

To compare the Gas Engine of *today* with one of a *few years ago* is like comparing the Automobile with the Velocipede.

SCIENCE has been working.

GAS today is the most efficient, economical, convenient and desirable power obtainable.

We have the Evidence. *Ask to be shown. We're ready.*

**The Peoples Gas Light & Coke
Company**

Michigan Avenue and Adams Street
Telephone Central 1076

this matter. While the gas company is interested in this way in having gas engines installed wherever possible, it does not actually engage in the sale of any one make of engine, to the exclusion of all others. It is primarily interested in seeing that gas engines are used, and that only engines which will give satisfaction when properly cared for are used to any extent. In other words, it does not desire to see engines installed where dissatisfaction is sure to result, and where "Gas for power" will accordingly receive a setback.

Referring to the accompanying reproduction, the original advertisement meas-

ured eleven inches square, the reproduction having been reduced to just one-half the size of the original. The design of the engine and pump, the flow of water into the tank, and the good display of the words, "Gas for Power," make a showing in even the large newspaper page, the black of the advertisement being very prominent on the page. The reading matter in the smaller type is logical, and, while it does not give the "reason why," the gas engine is "thoroughly satisfactory from all standpoints, and for all purposes," it wagers—so to speak—the word and experience of the gas company and its experts to prove the truth

UNDERWRITERS' REGULATIONS ON GAS PRODUCERS.

In our issue of August, 1903, we published the regulations of the National Board of Fire Underwriters regarding the installation and construction of gas and gasoline engines.

This board has just issued regulations for the construction and installation of coal gas producers, both pressure and suction systems. These requirements are as follows:

1. Pressure Systems—All pressure systems must be located in a special building or buildings approved for the purpose and at such distance from other buildings as not to constitute an exposure thereto.

2. Suction Systems—(a) A suction gas producer of approved make, having a maximum capacity not exceeding 250 H. P., may be located inside the building, provided the apparatus for producing and preparing the gas is installed in a separate, enclosed, well-ventilated, fire-proof room, with standard doors at all communicating openings.

The installation of gas producers in cellars, basements or any other places where artificial light will be necessary for their operation is considered hazardous, and will not be permitted except by special permission of the underwriters having jurisdiction.

The portion of these rules relating to the design and construction of apparatus are but a partial outline of requirements. A producer which fulfills the conditions herein outlined, and no more, will not be necessarily acceptable. All appliances should be

submitted for examination and report before being introduced for use.

(b) The smoke and vent pipe shall, where practicable, be carried above the roof of the building in which the apparatus is contained, and adjoining buildings, and when buildings are too high to make this practicable, the pipe shall end at least 10 feet from any wall. Such smoke or vent pipes shall not pass through floors, roofs or partitions, nor shall they, under any circumstances, be connected into chimneys or flues.

(c) Platforms used in connection with generators must be of metal. Metal cans must be used for ashes.

(d) The producer and apparatus connected therewith shall be safely set on a solidly built foundation of brick, stone or cement.

(d) While the plant is not in operation the connection between the generator and scrubber must be closed, and the connection between the producer and vent pipe opened, so that the products of combustion can be carried into the open air. This must be accomplished by means of a mechanical arrangement which will prevent one operation without the other.

(f) The producer must have sufficient mechanical strength to successfully resist all strains to which it will be subjected in practice.

(g) Wire gauze not larger than sixty mesh or its equivalent must be used in the test pipe outlet in the engine room.

(h) If illuminating or other pressure gas

is used as an alternative supply, the connections must be so arranged as to make the mixing of the two gases or the use of both at the same time impossible.

(i) Before making repairs which involve opening the gas passages to the air, the producer fire must be drawn and quenched and all combustible gas blown out of the apparatus through the vent pipe.

(j) The opening for admitting fuel shall be provided with some charging device so that no considerable quantity of air can be admitted while charging.

(k) The apparatus must have name plate giving the name of the device, capacity and name of maker.

For engines used in connection with these producers, see rules for gas engines.

SOME SCOTCH ENGINE AND PRODUCER TESTS.

Some time ago we mentioned that at the Glasgow show of the Highland and Agricultural Society of Scotland there were to be several tests made of gas engines and gas producers to bring the practical working of this form of motive power under the notice of agriculturists, who would be interested in cheap sources of power. Each exhibitor was to show two plants, consisting of suction gas producers and accessories and suitable engines of between 5 and 8 and 15 and 20 H. P. The following data has been taken from the preliminary report of the test. It will be noticed that in one or two cases the tests on half load showed a greater efficiency than the full load tests, which would indicate that an error had been made in measurement of the coal. While every precaution was taken to bring the fuel to the same condition in all producers at the end of the trials, it was, of course, an impossibility to secure exactness.

With the exception of the Crossley trial, ten hours were given to each test. In the Crossley case, 8 hours and 7 minutes were consumed in the test.

Table I. gives the details of the engines and producers.

Table II. gives tests of the plants which completed the tests, with no stops of any kind.

Table III. gives test of plants which had some defect of construction or operation. During these tests plant No. 8 stopped 8

minutes during the half load test, due to carbon deposit on igniter points. Plant No. 2 had the brake load relieved for two minutes, and the engine stopped for a few seconds to repair a pin on the ignition gear. No. 6 had the load off 9½ minutes on full load test, due to poor gas. The engine did not stop. No. 9 stopped during full load trial, due to shortage of water in the producer, and the load was relieved on brake for a few seconds during half load test on

TABLE II.

Plant No.	B. H. P.	Lbs. Coal per B. H. P. hr.	Load
8	20.57	.80	Full
7	9.74	.84	Full
1	20.44	.93	Full
5	19.98	.83	Full
7	5.38	.91	Half
1	10.69	.92	Half
5	10.72	1.08	Half

TABLE III.

Plant No.	B. H. P.	Lbs. Coal per B. H. P. hr.	Load
2	8.25	1.22	Full
6	8.34	1.25	Full
9	15.35	.77	Full
4	9.72	1.13	Full
8	10.43	.95	Half
2	4.43	.94	Half
6	4.57	1.48	Half
9	9.06	.96	Half
4	4.36	1.55	Half

account of premature ignitions. No. 4 stopped on half load owing to a defect in the producer.

Plant No. 10 was not ready at the time of starting and was not tested. Plant No. 3 had several stops during both tests.

It is interesting to note the time required

TABLE I.

Exhibitor	No. of Plant.	Rated B. H. P.	Bore inches.	Stroke inches.	R. P. M.	Cap. Producer cu. ft.
Campbell Gas Engine Co.....	1	18	9½	18	200	4.18
Campbell Gas Engine Co.....	2	8	7	12	230	2.26
Industrial Engineering Co.....	3	22	10	17	220	4.08
Industrial Engineering Co.....	4	13½	8½	14	230	2.17
Tangyes, Ltd.....	5	19	10	19	190	2.36
Tangyes, Ltd.....	6	7½	7	16	220	1.59
National Gas Engine Co.....	7	8	7	15	220	2.98
National Gas Engine Co.....	8	20	10	18	190	5.89
Crossley Bros., Ltd.....	9	18	8½	20	200	4.31
Acme Engine Co.....	10	22	10	17	220

by the various plants for getting started and up to full working load, starting with the producers empty and cold. No. 1 required 13 minutes; No. 2, 17½ minutes; No. 3 failed to start, owing to water passing into cylinder through the producer, and No. 4 was equally unfortunate, as it was compelled to stop after starting, owing to the water being shut off at main; No. 5 was started in 16 minutes; No. 6, in 12½ minutes; No. 7, in 15¾ minutes; No. 8, in 48 minutes; No.

9, in 15½ minutes, and No. 10 failed to start at all.

In addition to the above trials a "light load" trial was made to ascertain the capabilities of the producers to supply gas to the engines when running without any load. All of the plants completed this test, which was made without any record of coal consumption, etc.

Scotch anthracite pea coal was used in all the tests.

A SPECIAL ELECTRIC GAS ENGINE.

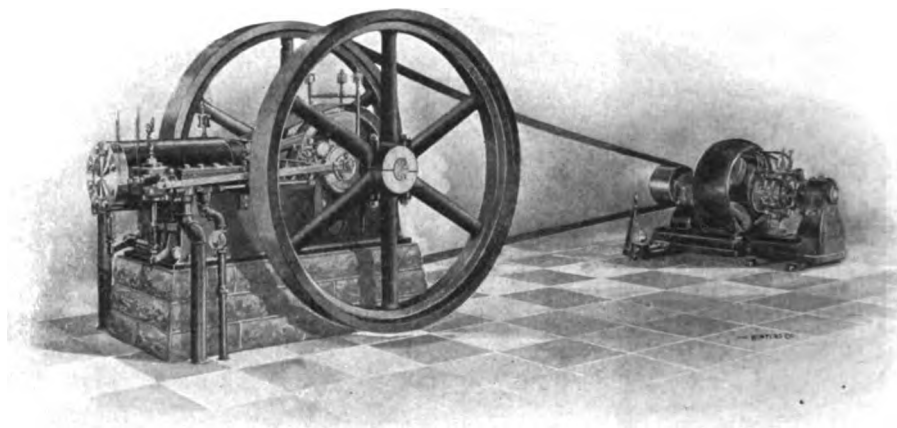

THE FOOS BELT-DRIVEN OUTFIT.

The operation of dynamos, especially direct connected, is, of course, one of the most difficult services to which gas engines are applied. Comparatively few single cylinder, direct connected outfits have been put out, but we are pleased to illustrate a unit built by the Foos Gas Engine Company, of Springfield, O., who state that in tests conducted the variation in speed between no load and full load was within 1 per cent.

The special electric type of Foos engine is very largely sold for store and factory lighting, and is especially adapted to isolated residence plants. The majority of these installations use belt-driven dynamos, the belt being carried by the large crown-faced flywheel, as shown in the accompanying illustration, and the regulator is such as to produce a light in which no variation is noticeable, and which really excels the

results with many steam plants. Any ordinary gasoline or distillate or gas can be used, and with the latter fuel throttling governors are usually applied.

The wipe spark system of ignition as employed in the Foos engines makes positive ignition certain and adds to the efficiency and reliability of the engine, this latter being especially necessary in electrical installations. Smooth running is insured by solidly bolting the counter-balancing weights, which are in the form of discs, to the arms of the crank, and thus between the bearings and in direct line with the parts to be balanced, rather than the usual arrangement of casting weights in the flywheels. This method of counterbalancing also relieves the bearings and crank shaft of considerable strain, and thus prolongs their life materially. The positive action of the

valves and their vertical position, which prevents side wear and deterioration of the valve seats, assists also in making the engine extremely reliable.

One of the features of this engine, which it would seem might appeal emphatically to practically every purchaser, is its extreme accessibility and the ease with which any

part can be inspected or removed without disturbing any other feature of the engine, or any of its pipe or other connections. Either valve, either portion of the igniter, the cylinder head, piston, rings, etc., can be handled as suggested independently, and without interfering with any other part of the engine.

NOTES FROM EVERYWHERE.

Gas engines operated on gas furnished by an R. D. Wood & Co. gas producer will be used at two pumping stations at the New Orleans drainage works.

The corporation of Widnes (England) furnishes coal gas for 29 cents per thousand cubic feet for power purposes.

Three Diesel oil engines, placed amidship, are used in a Russian oil boat to operate electric generators which transmit current to the motors which operate the propellers.

The Kittanning & Leechburg Railway Company, operating in Pennsylvania, has four 500 H. P. gas engines in its power plant at Garrett's Run, Pa. They are directly connected to 250 K. W. generators. A 20 H. P. gas engine also operates air compressors.

An English plan to utilize the waste heat

from gas engine exhaust is to generate steam in an apparatus which contains a coil of water pipe in the main exhaust pipe of the gas engine, which acts as the feed-water heater and which encounters the exhaust gas as it first leaves the engine. A special pump, driven by a shaft, feeds the cylinder jacket water through this feed-water heater and sends it to a boiler, which is composed of a single horizontal drum with a number of field tubes extending down into the exhaust space and in which the steam is generated. An outlet pipe from the steam space in the boiler proper is also formed into a coil in the upper part of the chamber through which the exhaust gas passes and thus constitutes a superheating coil. The steam generated may be used in an auxiliary cylinder in a two-cycle engine to drive the gas

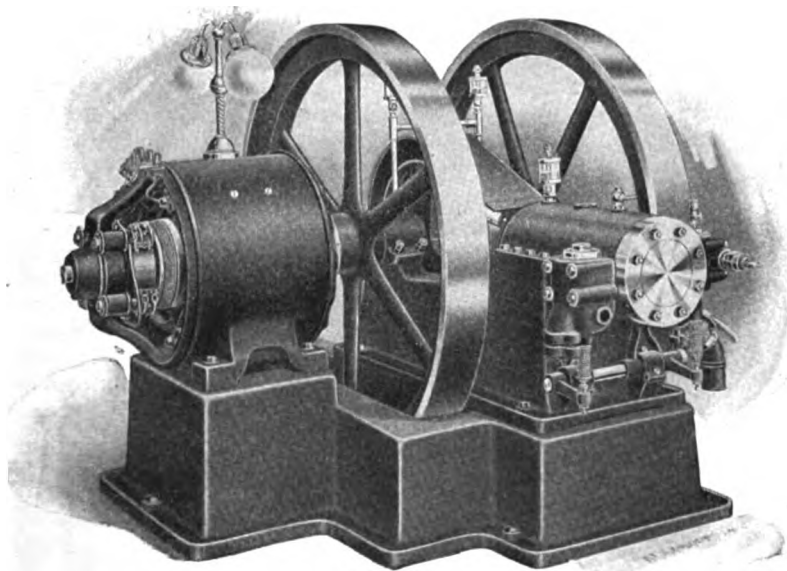

THE FOOS DIRECT-CONNECTED OUTFIT.

and air pumps, and which also acts as a starting cylinder for putting the main engine in operation.

On a test of a gas engine, reported by an English expert, gas of 578 B. T. U. was used, 11.77 cubic feet of gas was used per I. H. P. and 14.43 cubic feet per B. H. P. per hour. The engine tested 60.5 I. H. P. and 49.7 B. H. P. Based on the indicated power, the thermal efficiency was 37.43, based on brake power it was 30.8. The test was maintained for over six hours. The high efficiency shown was considered due to some extent to the injection of water which was brought into the cylinder through a special valve on the suction stroke. Air and water together are brought in, the water being broken up into a fine spray. If the water should reach the cylinder walls lubrication would be affected, but the test showed that much more water than was actually required could be admitted without affecting the lubrication.

A 26 H. P. gasoline engine, used in Texas for irrigating rice fields, cost \$1.50 in eight months for repairs. It was frequently allowed to run eight to ten hours without any attention, and at times ran as long as 100 hours continuously without stopping.

Two 160 H. P. Diesel engines in a central station in England showed the following cost items per K. W. hour, during a run of 112 days:

Fuel oil44 cents
Lubricating oil.....	.214 cents
Engine room stores.....	.022 cents
Water06 cents
Salaries and wages.....	.812 cents
Repairs022 cents
—	
Total	1.570

The engines were run at but 12½ per cent of their rated load. It is said that the average cost per K. W. hour for steam units, even in very large plants, is 1.76 cents.

GASOLINE ENGINE AND COMPRESSOR.

A correspondent of *The Practical Engineer* brings up a very interesting problem in the use of an air compressor and a gasoline engine working together.

"The proposal made is to lead the exhaust gases from the engine cylinder, by means of a pipe, through the air storage tank, in order to reheat the air. But there seems to be a still better arrangement possible.

"In a gasoline engine there is a large amount of heat taken away by the water circulating in the jackets; in a test which I have beside me of a 5 H. P. Priestman oil engine, the results are as follows:

Heat given in useful work...	12.67 per cent
Heat given to jacket water...	53.39 per cent
Heat given to exhaust, etc....	33.96 per cent

"It will be noticed that the largest loss is in the jackets, and it ought to be possible, by making the cold air take the place of the water, to get a saving here; unfortunately, special jackets would be necessary because of this fact, which must be borne in mind, namely, that air is a very poor conductor of heat, and in order that it may take heat from or give heat to an iron wall, it must have a scrubbing action given to it by the use of baffle plates or coils of pipe. Overcome this difficulty of making the air absorb

heat readily, and there is the possibility of a great increase in economy; unfortunately, I have had no experience in this work

"The advantages of reheating are obvious; it prevents the very great cooling of air working expansively, which cooling usually makes it necessary to provide an arrangement by which hot water or steam is injected into the cylinder, to prevent trouble owing to the freezing of moisture in the air; hot air occupies a larger volume than cold air at the same pressure, so that less of it is used per stroke, the relation being

$$V=v(1+\frac{t}{273})$$

where "t" is in degrees centigrade, which shows that the efficiency could be doubled could we only heat the air to 270 degrees C. The exhaust gases from a gas engine may reach a temperature of 800 degree C.; on this account the question of substituting air for water to cool the cylinder would require careful consideration, and it seems to me that much useful information in the heating of a volume of air, or what comes to the same thing, the cooling of a mass of hot iron, may be got by the study of the methods adopted for this purpose in automobile work."

ANSWERS TO INQUIRIES

It is our purpose to answer in this column inquiries of general interest which relate to the gas engine or its accessories. The questions will be answered in these columns only, and we reserve the privilege of refusing to answer any question which is not, in our judgment, of interest to the subscribers of THE GAS ENGINE.

All matter intended for this department should be addressed to The Editor of THE GAS ENGINE, Blymyer Building, Cincinnati, Ohio. The name and address of the sender must accompany the inquiry in all cases as evidence of good faith. The initials only of the sender will be published, together with the postoffice and state.

Write on one side of the paper only, and make all sketches and drawings on a separate sheet. Mark each sheet with the name and the address of the sender.

How much gasoline should a $5\frac{1}{4} \times 7$ -inch four-cycle engine running at 300 revolutions use at each charge or any number of charges? (b) What B. H. P. should this engine give supposing everything in good shape? (c) Can a magneto be used to operate a jump spark in connection with dry batteries for starting?—M. E. S., Cedar Rapids, Ia.

(a) .0004 pints per charge, 3.6 pints per hour; (b) 3.6 B. H. P. (c) Yes.

(a) Will 1-inch in take valve and $1\frac{1}{4}$ inch exhaust valve be large enough for a $4\frac{1}{4}$ -inch bore by 6-inch stroke gas engine at 400 revolutions? (b) How long should the compression chamber be, as there are no side pockets? (c) What power should such an engine develop?—J. B. W., Kenosha, Wis.

(a) Yes, ample. (b) $1\frac{3}{4}$ inches. (c) About $2\frac{3}{4}$ B. H. P. on gasoline and about $2\frac{1}{2}$ B. H. P. on natural gas.

I would like to know if oil can be used as a cooling medium in the jacket of a four-cycle 10 H. P. engine instead of water, and, if so, what kind and what quantity. The capacity of the jacket is about twenty-one quarts. The reason I ask is that the water we use destroys a tank very quickly, and the tanks are quite expensive; also, our tank is 3x8 feet, and, owing to its size and location, is very much in the way. I thought that if

oil would do, even if the first cost is a little more, it would be cheaper in the end, particularly if a smaller tank would answer. The engine has a $7\frac{1}{2}$ -inch piston, $7\frac{1}{2}$ -inch stroke and makes 300 r.p.m. on gas—D. A. S., New York City.

Oil has been used quite successfully for this purpose, the amount depending upon the facilities for cooling the oil. In automobiles we believe no increase in the size of the radiator was required. But the oil was used in winter only. The oil found best for this purpose is that known to the trade as "Ice machine" oil. Stationary oil-cooled engines usually employ a common steam radiator for cooling the oil.

Are two-cycle engines—say 4×4 -inch cylinder—built to run at as low speed as from 300 to 400 revolutions; my understanding is that a two-cycle is a much higher speed engine than a four-cycle? (b) Can you advise what the proper speed would be for a two-cycle engine of the above cylinder size? (c) If a two-cycle engine will operate at the above mentioned speed, will the power be effective?—A. B. J., Philadelphia, Pa.

(a) Yes, from 250 r.p.m. to 1,600 r.p.m. There is no great difference in the speed range of the two types if properly designed.

(b) For stationary work 600 to 750 r.p.m. For marine work up to 900 r.p.m. or 1,000 r.p.m., and for automobile work 1,200 to 1,600 r.p.m. (c) Certainly.

Please give the following information in connection with a three-port two-cycle, marine gasoline engine: Three-inch bore and $2\frac{1}{2}$ -inch stroke to run 1,000 to 1,200 revolutions. (b) Size of transfer space. (c) Size of exhaust pipe and vaporizer. (d) Should the piston rings be wider than the ports in order to prevent cutting into same? (e) Give method of making core box for water space, spherical head. (f) Thickness of crankcase—S. B. W., Belle Haven, Va.

(a) Cylinder inlet $5-16 \times 1\frac{1}{2}$ -inch, exhaust $7-16 \times 1\frac{1}{2}$ -inch, crankcase inlet $\frac{1}{4} \times 1\frac{1}{4}$ -inch, (b) $\frac{1}{4} \times 1\frac{1}{2}$ -inch, (c) $\frac{3}{4}$ -inch for each, (d) not necessarily. They may be pinned so that the opening in the ring can not turn to come opposite the ports. We would suggest

three rings $\frac{1}{4}$ inch wide. (e) We have not space to explain the method of making a jacket corebox. We advise the assistance of a first-class pattern maker; (f) 3-16-inch.

Referring to your "Handbook," written by Mr. Roberts, I find no mention made of the relation of volume to pressure in mixture of gas and air calculated to give the highest efficiency in a gasoline engine. I should be greatly obliged were you to give me what information you may have upon the subject. (b) I also find that all calculations are based upon a certain relation of piston stroke to diameter of cylinder, for an engine designed to be used in a carriage it would, under certain conditions, be a great advantage were the stroke short and the diameter of cylinder large. How far is it possible to carry this in an engine of about 6 H. P., 300 to 500 r.p.m.?—R. H. S., Cleveland, O.

(a) The relation of volume of pressure is given on page 110 of the "Handbook." The compression pressure for highest efficiency is the highest that the fuel will allow, the limit being that pressure at which the mixture will ignite prematurely. This matter is discussed in the fourth and subsequent editions on pages 252 and 253. In engines with water-cooled pistons, the compression may be carried much higher and even 160 pounds per square inch is said to have been obtained with such an engine on natural gas. (b) You are mistaken, as other formulas are given for any relation of the bore and stroke; 300 to 500 r.p.m. is low for the average automobile engine, the average piston speed of which is usually 800 feet per minute. We have seen some very successful automobile engines in which the bore was $1\frac{1}{4}$ times the stroke, and marines with a bore nearly $1\frac{1}{2}$ times the stroke, as $8\frac{1}{2}$ -inch bore by 6-inch stroke.

Relative to gas producers, (a) how many pounds of steam are required per pound of coal? (b) How many pounds of air per pound of coal? (c) What per cent of sulphur may a coal have and not seriously injure the engine? (d) In case of a coal with an excessive amount of sulphur, how is the gas purified? (e) What is the maximum velocity of gas through the generator and auxiliary apparatus?—D. R., Turtle Creek, Pa.

(a) The steam supply should be calculated to furnish about 2 pounds of steam

for each pound of coal consumed in the generator. The exact amount of steam can not be determined in advance; it must be adjustable according to the requirements of the process. Too much steam reduces the efficiency of the generator, as it cools down the burning coal too much, or may extinguish the fire altogether. The minimum is about $\frac{3}{4}$ pound of steam for 1 pound of coal. (b) Only so much air should be admitted as is necessary to keep the producer going. About one-tenth to one-sixth of the total amount of coal goes to keep the fire burning. In order to burn this part of the coal completely, about twelve times its weight of air is required. Consequently, from 1.2 to 2 pounds of air must be supplied for each pound of coal. An excessive amount of air injures the economy of the producer. (c) The anthracites used in European producer practice contain on an average of from .085 to .29 per cent of sulphur. The highest amount known of is 4.1 per cent. This does not damage the engine as far as could be ascertained. (d) In order to purify the gas obtained from a coal containing more than the above named percentage of sulphur, it will be necessary to provide a purifier of the same kind as is used in illuminating gas plants. Its contents should be so calculated that the gas travels at the rate of from 55 to 75 feet per hour. (e) The maximum velocity of the gas in the various apparatuses depends upon their size and design, which in turn are calculated upon the size of the engine and the combustible to be used. In the pipes the maximum theoretical velocity of the gas is about 5,000 feet per minute.

GAS ENGINES AT PORTLAND.

The Palace of Machinery, Electricity and Transportation, at the Lewis and Clark Exposition, is 500 by 100 feet, and is situated at the extreme eastern portion of the grounds. Fairbanks, Morse & Co. have a space covering 6,000 square feet and show a very complete line of their gas, gasoline, crude oil, distillate and producer gas engines. Combined engines and pumps, marine engines, electric light engines, etc., are shown, many of them in operation.

The Reiersen Machinery Company, Portland, show the Stickney gasoline engines. National engineering engines, Buffalo and Sarvent marine engines.

GOVERNMENT INVESTIGATION OF GAS ENGINES

The agricultural appropriation bill passed by the last Congress made the study and use of various kinds of agricultural power and appliances a part of the work of the irrigation and drainage division of the office of experiment stations. Mr. C. J. Zintheo, formerly professor of farm mechanics at the Iowa State College, Ames Ia., was appointed as expert in charge of the department.

In discussing the nature of the work to be undertaken, Mr. Zintheo recently wrote us as follows:

"We expect to take up investigations on the subject of denaturized alcohol as a substitute for gasoline for power, heat and lighting purposes. This alcohol can be produced from agricultural products, such as potatoes, barley, corn, beet pulp and sawdust. In Germany they are able to manufacture this alcohol for thirteen cents per gallon, and their experiments prove that they obtain more power out of a gallon of denaturized alcohol than can be obtained from a gallon of gasoline.

"We also expect to experiment with gas producer gas engines using lignite coal, which is found in such abundance in North Dakota and Eastern Montana, where large irrigation projects are now under way, and where it will be necessary to pump the water for irrigation. Lignite coal seems to contain a greater percentage of gas and more power can be obtained from it than from any other coal. If a cheap power can be found for pumping in irrigation and manufacturing purposes in that section of the country, it will cause great changes in its development.

"We also expect to take up experiments with traction engines for plowing purposes, and to make a comparison of cost and efficiency between the steam and gasoline traction engines in comparison with actual efficiency and cost of horses."

Laboratories for conducting these investigations are to be established, and we hope, at a later date, to be able to publish the results of some of these investigations.

THE PRODUCTION OF POWER GAS.

With the increasing attention which is being given to the use of internal combustion motors there has arisen a necessity for a more scientific treatment of the gas producer, and upon the design of this portion of a gas power plant much of the success of its performance depends. In a paper presented before the Verein Deutscher Ingenieure by Herr Karl Kutzbach, and published in the *Zeitschrift* of the society, the subject of gas producers for internal combustion engines is considered very fully, and some abstract is here given.

Doubtless the first producers of fuel gas were the blast furnaces used in the smelting of iron, and attempts to use this gas were made as early as 1814 by Aubetot, and more extensively in 1837 by Faber du Faur at Wasseralfingen, but the first systematic production of fuel gas in an independent producer seems to be due to Ebelmen, in France, about 1841. The apparatus of

Ebelmen appears to have been very complete, including the preheating of the air, forced blast and the introduction of superheated steam. By the use of a slag to act as a flux the noncombustible portion of the fuel was fused and drawn off in liquid form, the fuel being introduced by means of a funnel and cone. The gas made in these producers was used in puddling furnaces, and it was not until the introduction of the gas engine that the modern producer of Dowson was made, his patents being dated 1878 and 1883.

The Dowson system includes a producer, a steam boiler, an injector for delivering the air and steam into the generator and a scrubber, purifier and holder for the resultant gas. The Dowson system is excellent where the plant is of sufficient importance to warrant the introduction of a works of magnitude, and it remained for the development of the suction gas producer to adapt

the method to gas-power plants of all sizes.

Herr Kutzbach lays down the following principles which must be kept in mind in designing a successful gas producer system:

It must utilize the combustible to the best possible advantage, avoiding all loss of heat and producing a gas best adapted for use in the engine.

It must be entirely free from danger when in operation.

The costs of installation and of operation must be reduced to the lowest possible figure.

So far as the loss of heat is concerned, it is impracticable to carry the heat for any distance with the gas, and hence the heat of gasification of the fuel should be used in immediate connection with the producer, as in the production of the vapor and in the preheating of the air. Since the steam delivered into the condenser is decomposed by the incandescent fuel, a portion of the sensible heat is utilized in this way, while the superheating of the steam is also effected by the heat of the combustion in the producer.

Herr Kutzbach examines in detail the thermochemistry of the combustion which occurs in the gas producer, taking up the combinations of the oxygen of the air with the carbon of the fuel, and also the decomposition of the vapor of water, with the liberation of the hydrogen and the combination of the oxygen with the carbon. In addition to the chemical equations, the operations are shown graphically, employing the isometric diagram, and thus enabling relations of three variables to be plotted simultaneously.

The combustion in a gas producer takes place very differently from that occurring on a boiler grate, and the temperature is far from uniform in different parts of the apparatus. The temperature increases upwards from the grate until all the oxygen is consumed, after which it diminishes. The formation of carbon monoxide or dioxide depends upon the temperature at each point. The transformation of the carbon dioxide already formed into monoxide occurs in the heated layers and the inverse change in the cooler portions, these going on simultaneously. The gas is thus a mixture of the two formations, changing at different points according to the temperatures. In producers operating at a high temperature the proportion of carbon dioxide is small, running as low as 1 to 2 per cent.

In considering the operation of the gas producer it is necessary to decide upon the most desirable mixture for use in an engine. The combustible elements are the carbon monoxide and the hydrogen, and the relative proportions are variable. The hydrogen has a much lower ignition temperature than the carbon monoxide, and also a much higher rate of combustion. It is also diffused more rapidly into the air, and it requires a greater excess of air for its combustion than the monoxide. In view of these properties it is the proportion of hydrogen which must be considered. If there is too much, the action of the engine will be effected, either by pre-ignition during the compression stroke or by too violent explosions. If there is too little hydrogen present the gas will be sluggish in igniting. In practice it is found that there should be from 10 to 15 per cent of hydrogen in the gas, corresponding to about 5 per cent in the mixture of gas and air delivered to the engine cylinder.

So far as the practical proportions of producers are concerned, these have an important influence upon the performance. The combustion taking place in the interior of the mass of the fuel, the dimensions depend somewhat upon the sizes of the pieces, or rather upon the active surface exposed by the lumps. For convenience in operation it is desirable that a producer should hold enough fuel to be able to run for at least five hours without charging. If the producer is not well proportioned there will be unburred air passing through to the upper portion, and some of the carbon monoxide will be converted into dioxide. The area of the grate should be materially smaller than is indicated for a boiler furnace, this because of the smaller proportion of air required. In ordinary instances the grate may be about one-half the area required for a boiler furnace consuming an equal quantity of coal, and if the draft is assisted the grate area may be made even smaller. The amount of air required is only about one-third that demanded for the complete combustion of the coal in a boiler furnace, and the air spaces in the grate may be proportioned accordingly.

The most serious practical difficulty in the operation of gas producer is found in the formation of slag and cinder. The cinder gathers in the lower portions of the producer, but when it is of a partially fusible nature it forms masses of clinker in the shaft of the

producer, requiring to be broken up by poking or barring through holes arranged for the purpose.

Various methods have been devised for removing the cinder. In the blast furnace the flux renders the slag fluid, and it can be tapped off in the liquid form, and this method was also adopted by Ebelman, as noted above. Another method is that of periodically cooling the producer by the admission of an excess of steam, this causing the cinder to break up more readily. The reversed draft producer is also used to avoid trouble with cinder, the slag being readily removed from the bottom.

So far as the second condition—that of security—is concerned, it is included in ordinary carefulness. The charging should be regularly attended to, and a constant proportion of air and steam supplied. Herr Kutzbach suggests the great desirability of some kind of a device which should indicate con-

tinuously the composition of the gas as it is produced, this serving a similar purpose to the pressure and water gauges on a steam boiler. Such an indicator would be of especial value in large plants where the opportunity for variation is greater than in a small installation, which may be so adjusted as to be practically automatic.

The economy of gas power installations is fully understood. A gas producer has an efficiency of at least 75 per cent, equal to that of a steam boiler. The efficiency of the gas engine, however, is 25 to 30 per cent, as against 10 to 15 per cent for the steam engine, the resultant total economy being 40 to 70 per cent in favor of the gas engine plant. Especially is the advantage seen in the case of small installations, since the small gas engine is as efficient as the large one, while the small steam engine has a far lower efficiency than the above figures.—*The Engineering Magazine*.

CHEAPER GAS FOR POWER IN BIRMINGHAM.

The gas companies of England are under governmental control, and the quality of the gas is also maintained by law. The price of gas for power is one of considerable interest to the gas company, and in order to compete with electricity for light and power concessions are sometimes made.

On July 18 the Gas Committee of the Birmingham City Council reported on the charges for gas to be supplied for use in gas engines.

In July, 1903, reductions in the prices to be charged for gas were sanctioned by the Council, based, as hitherto, on the quantity used by a consumer in one building, regardless of the purpose to which the gas was applied; and the lowest charge in the scale was forty-four cents per 1,000 cubic feet, less a discount of 5 per cent on the usual terms, where the volume of gas supplied exceeded a million cubic feet per quarter. The committee received communications from manufacturers directing attention to the reduced charges made to their competitors by companies in surrounding districts for gas used for motive power; and inquiry showed that such arrangements are made in the following manufacturing centers:

Bristol, Bury, Darlington, Derby, Glasgow, Leicester, Longton, Manchester, Newcastle, Nottingham, Rotherham, Sheffield, Stafford, Stockport, South Shields, Stoke-on-Trent, Wigan, and also in the neighboring towns of Oldbury, Smethwick, Stourbridge, Walsall, West Bromwich and Wolverhampton. The attention of the committee was also directed to the development and perfecting of appliances for the manufacture of a gas that can, under favorable conditions, be substituted for corporation gas for motive power purposes; and, after fully considering the position, they recommended that all gas for use in engines, irrespective of quantity, should, as from the next quarterly reading of the meters, be supplied at the lowest current rate of forty-four cents per 1,000 cubic feet, with a discount of 5 per cent on the usual terms, or slightly under forty-two cents per 1,000 cubic feet net. Gas used for engines will, as hitherto, be registered through separate meters. There are, it is stated, between 2,00 and 3,000 users of gas for power purposes in the district of the Birmingham gas supply; while the amount of gas so employed is about 15 per cent of the entire output. Many of these con-

sumers have complained of the disadvantage they are under through their competitors in other places, including immediately adjoining districts, having gas supplied to them for power at a reduced charge. The stress of this competition has also led many of the larger users to put down gas-producers of their own. As will be seen, it is not proposed to put the user of gas for power upon the rate hitherto enjoyed only by the largest consum-

ers. At present consumers of under 50,000 cubic feet per quarter pay fifty-four cents per 1,000 cubic feet; and placing them on the minimum scale will be equivalent to a reduction in their case of sixteen cents per 1,000 feet. For consumers of between 50,000 and 250,000 cubic feet, the proposed reduction works out at four cents per 1,000 feet, and to consumers of between 250,000 and 1,000,000 cubic feet, at ten cents.

THE LAUNCH GREGORY.

Ninety feet long, with a 12-foot beam and 4-foot draft, this launch is propelled by two 300 H. P., six-cylinder, reversible Standard gasoline engines, and is lighted by a Standard direct-connected electric light plant of 4 H. P. The boat contains forward three tanks, with a capacity of 1,500 gallons; she also contains four tanks aft, with a capacity of 2,500 gallons, making a total of 4,000 gallons, which equals in weight, approximately, 13 tons. With 6 tons of fuel aboard, the total weight of the boat was designed for 30 tons displacement.

It will be noticed that when driving under one engine, with the other propeller uncoupled, so as to allow it to rotate freely, the boat can sail 5,050 miles when running at the rate of 7.77 miles per hour. When running at the rate of 10.63 miles per hour she can sail 4,600 miles. When running at the rate of 13.16 miles per hour she can sail for 3,360 miles. It will be noticed in comparing these figures with the work of the Government torpedo boats that sailed to Manila, that the fuel consumption is far more economical than with coal. The smallest Government boat carried some 190 tons of coal when leaving San Juan, and, steaming at the rate of 10½ miles per hour, they found it necessary, or considered it so, to coal at sea before arriving at the Azores, a distance of only 1,700 miles. To compare these figures with the "Gregory," a boat much smaller in every way, which carries only 13 tons of fuel, but is able to operate more than 2½ times as far without resorting to deck loads and auxiliary fuel storage compartments, certainly indicates the great advantage that the internal combustion engine operating on liquid fuel has over steam on long cruises.

The maximum speed of the boat has not as yet been exactly determined, a speed of 23 miles having been made while the boat was loaded beyond her regular trim. Under these conditions the fuel consumption is some sixty odd gallons per hour. This would drive the boat at full speed nearly 1,400 miles, which is again considerably more than high-speed boats of the torpedo type could ever accomplish.

*TABLE OF PERFORMANCE.

R.P.M.	Speed.		Fuel per hour. gallons.	Radius of action.	
	Knots.	Miles.		Days.	Miles.
145	6.75	7.77	6.12	27.3	5,050
202	9.23	10.63	9.6	17.4	4,600
252	11.43	13.16	15.65	10.7	3,360
322	14.50	16.70	32.7	5.1	2,040

The "Gregory" had a very difficult passage across the Atlantic, having left New York originally January 5 for Bermuda, and being driven back by a high storm. She left again February 8 and reached Bermuda February 16. On March 1 the voyage was resumed, the boat heading for the Azores. Another storm being encountered, however, she again had to put back to port with one cylinder broken. She finally left Bermuda March 19 and reached the Azores April 4, after having passed through another heavy storm. The provision of gasoline was now exhausted, and it was necessary to await a new supply from Lisbon, which required a stay of more than a month. On May 10 the Azores were left and Algiers reached the 17th. Since that time the motor boat has passed through the Dardanelles and arrived at Sebastopol, where she was turned over to the Russian Government for use as a torpedo despatch boat.—*Marine Engineering.*

*Port engine running. Starboard propeller uncoupled.

TEST OF A PRODUCER, ENGINE AND PUMP.

At Poughkeepsie, N. Y., there is an interesting pumping plant, comprising a 50 H. P. suction producer, made by R. D. Wood & Co.; a 35 H. P. vertical, two-cylinder gas engine, made by the Westinghouse Machine Co., and a Worthington belted 10-inch volute pump, with enclosed impeller 28 inches in diameter, driven at 450 r.p.m.

The tests were made by a water meter measuring a fractional part of the total flow through a by-pass in the delivery pipe. The ratio of the quantity recorded by the meter to the total discharge was ascertained by allowing the entire amount to enter two watertight basins, having a combined area of 28,853 feet, and noting the rise in them by means of hook gauges reading to 0.001 foot. The pressure gauge on the discharge pipe was tested by a water column 25 feet high and found to register 1.36 foot too much.

The combined efficiency of the belt and pump was determined by ascertaining the B. H. P. of the engine and dividing the power due to the volume pumped and the total lift by it. The separate efficiency of the belt and pump is estimated. The brake test gave 38.8 H. P.

The test of the entire plant, using anthracite pea coal, gave the following results: Total cubic feet of water pumped in 24 hours, 427,856; pounds pumped per minute, 18,521; delivery head, 21.5 feet; suction head, 17.03 feet; net water H. P., 21.62; combined efficiency of pump and belt, 0.557; total coal consumed, 1,151 lbs; coal consumed per H. P. hour, 1.23 pound; duty of entire plant, 89,211,691 foot-pounds per 100 pounds coal. These figures are furnished on the authority of Mr. Charles E. Fowler, superintendent and engineer of public works.—*The Engineering Record*.

THE GAS TURBINE.

That many engineers of considerable prominence have great faith in the utility and superiority of the gas turbine as a prime mover is shown by the large amount of speculative literature which has already made its appearance, and by the considerable amount of experimental work done to perfect such a motor.

The result of all this analysis and experiment has established more than one fact which seems to present a serious difficulty, under the present state of the mechanical art, to the successful operation of the gas turbine.

Two of these difficulties are the preparation of the working fluid at the high pressure necessary and the inability to use the gas at the very high temperature resulting from the preparation. To put it more concretely, it seems to be extremely difficult to continuously burn oil or gas under the extremely high pressure, and also to find materials which will withstand such temperatures as are produced.

Again, in the turbine itself, these temperatures are such that the metal is heated red-hot, and even if such temperatures

are not high enough to impair the strength of the metal, they create a condition under which it is quite impossible to operate a turbine. The resulting deformation or change in the running and fixed parts as the temperature changes and the impossibility of lubrication, constitute two of the operative difficulties.

The concensus of opinion seems to be that with ideal materials for constructive purposes, the gas turbine would be the most efficient motor, but that the present state of constructive art must be greatly improved before such a motor will be a successful reality.

The foregoing applies to the pure gas turbine, operating with what are known as fixed gases. When the combination of gas and steam is considered, the problem is altered and the difficulties reduced, both in size and number. Without discussing in the abstract the character of the new problem, consider the construction and action of what the designer calls a wet-gas turbine.

The combustion of the fuel, either gas or gasoline, takes place in the cylinders

SOME EUROPEAN TENDENCIES.

BY OSWALD H. HAENSSGEN.

(Continued From P. 258, August Issue.)

The principle of the "Bosch" multi-cylinder magnetos is the same as in the single cylinder types, though the general construction has been considerably modified.

The same size of apparatus serves for motors with two, three, four or six cylinders, the only difference lies in the distributor and interrupter devices. The principal dimensions of this type are: Total length 10¾ inches, width 4¾ inches, height 8½ inches. It possesses three horseshoe magnets consisting of two bars each, 1 9-16 inches wide, and ¾ inch thick, and the weight is 22 pounds.

A unique feature is that the armature is stationary, instead of rotatable. The movable portion of this apparatus consists of two cylinder segments of soft iron which rotate in the narrow annular space between the armature and the magnetic shoes. The cylinder segments comprise two quarters of a circle and are set exactly opposite. They are fixed to circular discs, one of which terminates in the driving shaft of the magneto, and is partly bored out to form a support for the round pin of the armature. The disc on the other side possesses a long hub, through which passes the other supporting pin of the armature. The hub carries the cam sleeve for the interrupter, as well as the distributor device. The last mentioned pin of the armature is fixed to the magneto housing. By the arrangement of a stationary armature the sliding contacts are done away with, and the current may be taken directly by a fixed wire. The rotating portion becomes extremely light in weight and is consequently very well adapted to high speed. This renders the magneto especially desirable for many-cylindered high-speed two-cycle motors, in which the magneto works at the speed of the main shaft.

The current attains its maximum four times during every revolution of the magneto-shaft. Consequently four sparks may be obtained in the same time. For two and four cylinder engines the apparatus rotates at the speed of the gear shaft, while for three and six cylinders it must run one and one-half times as fast. There is only one interrupter lever for any number of cylinders. It is fulcrumed to the timing lever,

and by shifting the latter any desired lead of ignition may be had. The interrupter is actuated by the aforementioned sleeve, which carries the necessary number of cams on its face. Beside this cam sleeve is mounted the distributor disc, from which the current is sent to each cylinder by an equal number of carbon plugs. In order to avoid damage to the winding of the armature when the magneto is running while a spark plug is cut out of circuit, a special spark gap is provided between the primary and secondary circuit. When the spark plugs are in good condition no spark is formed at this safety gap. But if a plug misses fire on account of short circuit or the like, a spark will appear. This is accompanied by a characteristic noise and indicates that something is wrong.

It will be noted that the magnetos of "Bosch" manufacture work without a spark coil proper, the friction of same being performed by the secondary wire on the armature. It is claimed that the spark obtained has an excellent igniting effect. While a mixture of fifteen parts of air with one part of gas is just at the limit of ignitability by a common battery, Mr. Bosch claims that his magnetos ignite a mixture as poor as nineteen parts of air and one part of gas with safety.

The magnetos of Eisemann impress one very favorably. Every part of them is well designed and of liberal dimensions. Especially the interrupter device differs materially from the flimsy contrivances often seen in other makes. The armature rotates between the magnets and generates a low tension current. The front, or driving end of the shaft, has a taper part for the driving wheel, which is fastened by a large nut. The rear end carries a steel cam operating the interrupter lever. The latter is double-armed and pivoted in its middle. One arm is forked and receives a hardened steel roller that bears upon the cam, the other arm is provided with an adjustable tip of platinum. The other contact point is also adjustable, and is fastened in a support insulated from the body of the machine, but in electrical connection with the winding of the armature. The support possesses also a binding post for the primary wire leading to the

spark coil. This apparatus is entirely separate, its wiring is calculated to harmonize fully with the armature, and being of ample length it produces a good spark. Only one coil is required even for the multi-cylinder magnetos. In the smallest type of the Eisemann magneto which serves for bicycle motors, the interrupter device may be swung about the shaft in order to time the spark. The lever permits a movement of 29 degrees. This machine has three pairs of magnets, each bar is $\frac{7}{8}$ inch wide and 5-16 inch thick. Its total length is 7 inches, its width, including the timing lever, is $4\frac{5}{8}$ inches, while its height is 5 5-16 inches.

This size of magneto is also built for two-cylinder motors. In this case a distributor is placed above the driving shaft and is moved by a pair of spur gears at half the speed of the shaft.

The larger types for car motors have a timing device of peculiar design, which is illustrated in Fig 6. The shaft of the arma-

ture and the interrupter are simultaneously varied, the intensity of the spark remains the same throughout.

The same types are used for stationary work also, but in this case the timing device has been dispensed with. Experience shows that the magneto may be fixed in the position proper for full speed of the motor, as no spark occurs unless the flywheel rotates fast enough and has gathered sufficient inertia to overcome the back pressure of somewhat early ignition. As the quick motion of the motor shaft is only necessary just about the moment of interruption, no special exertion on the part of the operator is required. A short, sharp pull at the starting crank suffices, and if everything else is in good order the first spark should set the motor running. This applies to all magnetos with jump spark ignition, the position of the starting crank in relation to the motor crank must be properly chosen in order to render starting easy. This question of starting

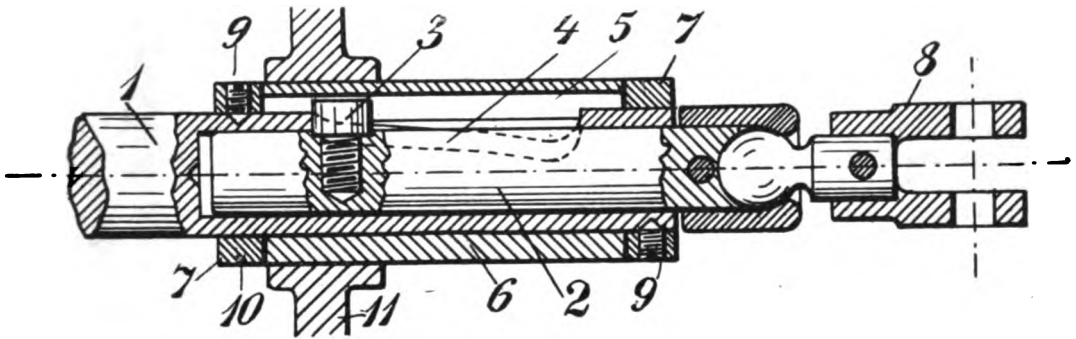

Fig 6.

ture, marked (1), is bored out and a bar (2) is fitted slidingly in the bore. A pin (3) screwed into bar (2) projects through the curved slot (4) of the shaft (1) into the straight slot (5) of a bushing (6). This bushing is secured laterally by two collars (7) that are fitted upon the shaft (1) and held in position by four setscrews (9). The setscrews are protected from working loose by an open ring (10) of steel wire laid into a narrow groove in the collar. A driving gear (11) of any desired shape is fitted upon the bushing (6). The forked piece (8) is attached to the shifting bar (2) by a ball joint, it serves to couple the timing lever.

The stroke of the bar in a longitudinal way is 1 9-23 inches, whereby a lead of about 30 degrees, measured at the shaft of the magneto, is obtained. As the positions

will be touched upon later.

The various patterns are adapted to multi-cylinder work without change in their exterior dimensions, simply by adding a distributor. This device consists of a disc of non-conductive material having a short brass contact piece fitted in its circumference. Arranged about this disc and properly spaced are fixed upon well insulated pivots a number of pawls, one for each cylinder. The terminals for the high tension wires are connected to each individual pawl, while the secondary wire from the coil connects to the contact piece. The pawls are gently pressed upon the distributor disc by little springs. It has been mentioned that the distributor is rotated by spur gears, the ratio of which varies with the number of sparks required.

The Eisemann magnetos are wired as follows: The apparatus must be in metallic connection, with the motor and the body of the spark plug. The terminal at the magneto which is in electrical connection with the stationary contact piece receives the wire leading to the spark coil terminal of the primary winding. The other primary terminal of the coil is grounded on the body of the engine. The third terminal of the coil serves to attach the heavily insulated secondary wire which in a single cylinder engine leads directly to the spark plug, while in multi-cylinder motors it is connected to the binding post of the distributor.

The magnetos "Rapid" are built in various styles and sizes. The types for direct jump spark ignition are notable for the immense length of spark obtained. The author found that at 500 r.p.m. the spark would jump easily and regularly a distance of $1\frac{1}{4}$ inches between two ends of wire in the open air. Even the smallest type, intended for bicycle motors, gives a spark of $\frac{1}{2}$ inch. While thus the electrical performance is excellent, the mechanical part of these magnetos, especially the interrupter device, seems to be rather weak, and in the two and four-cylinder types, somewhat inaccessible. By a little study the designer might easily obtain the necessary harmony. The spark coil is encased in a moisture proof, hard rubber box that closely fits the place between the magnets. As all the dimensions of the electrical portion are very large, the available space suffices for a coil of enormous capacity, as is proven by the large sparks. The single cylinder type is $11\frac{1}{4}$ inches long, $4\frac{3}{4}$ inches wide, 8 9-16 inches high and weighs 26 pounds. Its interrupter consists of a spring retained lever, pivoted at one end, having a little roller in the middle and a platinum contact tip at the free end. A steel cam upon the shaft of the armature actuates the lever. The other contact piece is insulated and is connected to the short primary wire leading to the coil. The whole device is encased and the case is fulcrumed upon the shaft. By turning it about the latter the moment of interruption may be varied within certain limits. Careful tests of the author showed that this magneto easily starts a motor of five-inch bore at the first pull of the starting crank, the igniter was set at the full speed lead. If interruption was set to occur exactly at the innermost portion of the piston, however, it was impossi-

ble to start, and there was no spark. If ignition was set back to this point while the motor was going full speed, good and regular sparks were obtained. The explanation for this phenomenon is not difficult to find. By reference to Fig. 6 it will be observed that in the Eisemann timing device the perfect synchronism of the maximum of current and the moment of interruption is maintained at any position of the timing lever and thus the greatest force of current is always utilized for the spark. In the Bosch, as well as in the "Rapid" magnetos, simply the moment of interruption is changed while the position of the armature in relation to the piston of the motor remains constant. Consequently the maximum of current does not always coincide with the moment of interruption, and, especially at low speed of the magneto, soon a point is reached at which no spark at all occurs. As for starting, a good spark is required at very low speed the moment of interruption should be so far advanced as to come close to the maximum of current. At high speed of the apparatus the output of electricity is so much greater that even a considerable divergence will do no harm, and thus the magnetos are very handy to manoeuvre automobile motors by the lead of ignition.

The multicylinder type of the "Rapid" magneto is $12\frac{7}{8}$ inches long over all, $4\frac{3}{4}$ inches wide, 8 9-16 inches high and weighs 32 pounds. Its interrupter is of the same design as for the single cylinder apparatus. On the front end of the shaft a simple form of commutator is arranged whereby the output of the generator is turned into a continuous current. At the opposite side of the magnets is placed the aforementioned interrupter and also the distributor. This latter device rotates either directly with the shaft of the armature, or it is placed on an auxiliary shaft laid parallel thereto and driven by two spur gears at such a speed that the proper number of sparks is obtained per revolution.

The "Rapid" magnetos have no binding posts, the high tension wires are directly fixed thereto, they are furnished sufficiently long to be cut to measure at the engine. While this arrangement warrants a perfect connection, it renders the exchange of the wires rather difficult.

All the magneto-electric generators heretofore described possess magnets of horse-

shoe shape, the current attains a maximum only twice during every revolution of the armature. Consequently the magneto, as well as the interrupter, must work in exact relation to the motor in order to give good results.

The wear of the small contact and distributor parts is sometimes excessive, partly from mechanical causes, but mostly by action of the current. Especially the tips of the contacts, though being made of platinum or another precious metal are liable to burn and cause expensive repairs. For motors with different numbers of cylinders, the common bipolar magneto calls for variations in the number of revolutions of the armature or of the distributor in order to obtain the desired number of sparks. Other difficulties arise if the magneto must be adapted to multi-cylinder two-cycle engines.

All these disadvantages are overcome in the "Pittler" magneto. It gives a maximum of current twelve times during one revolution, and, consequently, needs no adjustment to the motor. There are no wearing parts during regular work, except the two main bearings. It may be used for any number of cylinders without any change, and may yet run at comparatively low speed.

In spite of all these favorable features it is not at all complicated, but may rather be

called one of the simplest machines of its kind. In its exterior appearance it is a small drum provided with four lugs to fasten it. It may be driven in any suitable manner in either direction, its action is noiseless. In construction it is somewhat similar to a dynamo. Six horseshoe magnets, each composed of many thin sheet steel slabs, are grouped around and fastened to a central shaft. The twelve poles of the magnets, north and south poles alternating, are equally distributed about the shaft. Around this body is arranged a ring having on its inner circumference twelve tooth-like projections that are surrounded by coils of insulated wire. The ends of this wire are fixed to a stationary collector. A couple of sliding contacts are hinged to levers fastened upon the shaft. These contact pieces are gently pressed upon the collector by springs. At the normal rotative speed of the generator the centrifugal force acting upon the contact pieces overcomes the tension of the springs and lifts them off the collector. In this case the contact pieces rotate without touching anything. The current passes an induction coil which, however, needs no trembler. At low speed the contact piece rides upon the collector ring. The circuit is thereby frequently opened and closed, similar to the action of a trembler, high tension extra cur-

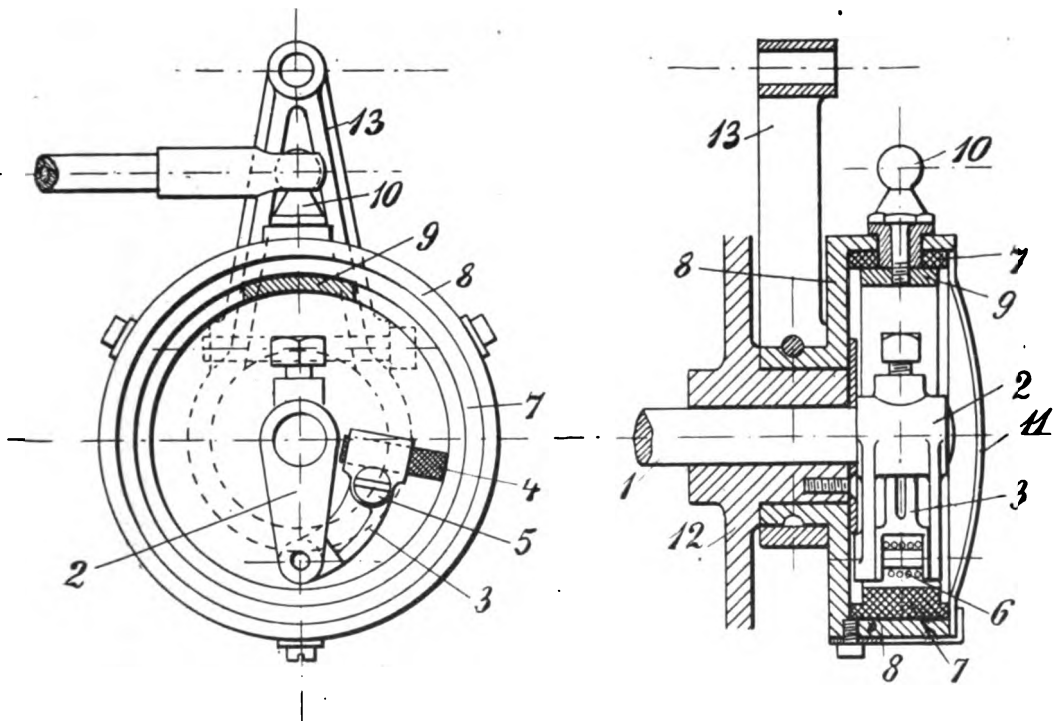

Fig. 7

rents are generated which suffice for ignition. When the contact pieces fly apart at full speed the direct alternating currents are utilized. If for any reason the motor slows down considerably the centrifugal force weakens and the brushes are drawn upon the collector again by the springs. This action, produced by an arrangement equally simple and ingenious, is entirely automatic and warrants very nearly an equal force of current when starting and when going at full speed. The magneto produces not only *one* spark at the proper time, but it sends into the compression chamber of the motor a great number of sparks in rapid succession, beginning with the moment of ignition and extending far into the explosion stroke. Hereby the value of the "Pittler" system of ignition is much enhanced, a missing of explosions is practically impossible.

The wear of the apparatus is reduced to a minimum as the contacts slide only during the short time of starting. A valuable adjunct to the magneto is the distributor furnished by the same maker. It does not form part of the former, but it is mounted separately upon some rotating member of the motor, preferably the gear shaft. In this device the centrifugal force is utilized in a way just opposite, namely to increase the friction of the contacting parts at the higher rotative speed. The construction of the distributor is plainly shown in Fig. 7. The shaft (1) carries a forked crank (2) to the end of which is pivoted a lever (3). A brush (4) made of fine copper wire gauze is held in the free head of the lever (3) by a screw (5). A little spring (6) wound about the pin of the lever tends to press the brush against the inner circumference of the fiber ring (7) which is fitted into the casing (8). According to the number of cylinders to be ignited, one or more segments are cut out of the ring (7) and replaced by brass pieces (9). These pieces are fastened by screws that pass the metal of the casing through insulating bushings and terminate in ball-shaped buttons (10) to which the wires are clamped. The casing (8) is closed by a cover (11) in front, it is fitted upon a suitable stationary part (12) and may be turned by the lever (13) in order to time the moment of ignition.

The copper wire brush of this distributor is a feature derived from dynamo practice, it offers many advantages here. The thin points of the wire easily penetrate any layer

of oil that may possibly form on the sliding surface of the fiber ring. They yield elastically to the pressure of the centrifugal force which causes them to bear the harder the faster the motor runs, whereby the effect of the vibrations is annulled and a perfect contact obtained under all circumstances. The brush is self-adjusting and self-cleaning, it is easily and cheaply replaced when entirely worn down.

The "Pittler" distributor is no doubt one of the most perfect sliding contacts, its mechanical construction is well conceived, and warrants great durability and reliability.

Before leaving the present subject the author may be allowed to say a few words concerning the mechanical construction of the modern magnetos, to point out the general objections thereto, and to suggest some remedies.

Taking a look at the method of fastening the driving gear to the shaft of the armature, it will be noted that with very few exceptions the gear is fitted upon a taper part of the shaft and held there by a nut in front.

The whole method is obsolete and nothing but a revival of the time-honored arrangement first used with oscillating magnetos.

The taper on the shaft of the armature is a nuisance, it is, of course, different in each different make of magneto, and even differs frequently in magnetos of the same make. It is more expensive and more difficult to produce exactly than a straight shaft. The taper in the driving gear is also very disagreeable for the same reasons, as it never allows fixing the gear exactly in a lateral way. Even if the angle of the taper were correct in both parts a slight difference in the diameters would throw the gear to one side or the other considerably. The rut in front of the gear is also a source of trouble, as it frequently works loose. It is almost impossible to tighten it thoroughly, as there is no possibility to counteract the turning effect of the spanner. The shaft can not be held in place at its front end, while to hold the armature at the rear end is dangerous, as the latter is not capable of transmitting a great strain and as the tender distributor-parts are liable to be crushed by the application of some powerful tool. The only tool is the human hand, with the result that the gear will work loose often. To secure the gear against turning upon the shaft a key is used, or a taper pin is driven through

the hub and the shaft. The pin, however, is very troublesome, as it is generally deformed by the pressure of the nut and can no more be withdrawn. If it becomes necessary to dismount the gear, more trouble is experienced, and only by special appliances can this be done safely and damage avoided. Certainly the common crow-bar practice is responsible for infinitely more destruction of magnetos than the regular wear. The defects of this method of fastening the driving gear, here enumerated, might be mitigated in various ways, but it would be better to abolish the taper altogether. This step has been ventured in the types of the Eisemann magnetos that are equipped with the timing device illustrated in Fig. 6. Possibly the designer regretted at one time very much that he could not provide the much beloved taper, while in reality he had created a notable improvement.

Each magneto should have a straight driving shaft of at least $\frac{5}{8}$ inches diameter and about 1 inch long upon which the gear could be fitted. If the key seat was milled in at once the bearing would not be damaged. The makers should teach their customers the use of proper tools, or should even furnish one with every magneto. If two holes are drilled in the web of the gear close to the hub and on one diametrical line, two bolts may be inserted which are connected by a bridge-piece. A screw working in a tapped hole of the bridge and pressing against the end of the shaft will withdraw the gear easily and without doing any harm. If it is desired to have a nut in front of the gear there should be left between the rear face of the latter and the magneto-housing a space sufficient to apply a spanner to the shaft, which for this purpose should have either two flat faces or a hexagon part.

The opposite end of the shaft carries the interrupter, which is also a sore point in magneto design. There are two kinds to be distinguished. In the one the cam rotates while the contact lever is pivoted upon a stationary part. The other kind has a stationary cam and the lever is carried around by the shaft. The first arrangement, as used in the Eisemann and Rapid generators, is preferable. The cam is small and travels at a low circumferential speed. It causes very little wear and may be well hardened, too. Only one stationary contact piece must be insulated, and this is easily and perfectly effected. The second arrangement is only

found in the Bosch magnetos. As the cam encircles the entire interrupter, it is necessarily very large and the head of the lever travels a much longer distance at equal rotative speed as in the first case. Consequently the cam, as well as the lever, wears considerably. The cam must be insulated, on account of its large size the frail insulating material is a very weak structural member. If it is also called upon to form the operating surface of the cam, this is a decidedly objectionable feature and should be strictly avoided. This construction is, to a great extent, also responsible for the smallness of the interrupter parts, as the space within the ring-like cam is too narrow to allow the disposal of large bearings, pivots and bushings. Thus the closeness of the available space may be one of the principal causes for the insufficient dimensions of the distributor parts in this case, while in other cases perhaps either negligence or ignorance are the causes. If it be remembered that every change in the position of the interrupter causes a many times greater variation in the moment of ignition, or rather in the relation of the spark to the position of the piston, it is easily understood that even a slight inexactness, caused either by bad workmanship or by wear, will result in great irregularity of ignition. Especially is this true for multi-cylinder motors in which many rather mysterious difficulties may often be traced to some imperfection of the interrupter. In such a case it is often found that each cylinder singly works very well, but requires a special adjustment of the magneto, that is to say, the position of the interrupter is different for each cylinder. Consequently it is impossible to obtain a correct adjustment for all cylinders, and probably none of them will work under the most favorable conditions. This may to some extent account for the fact that the multicylinder motor does not produce so much power as might be expected by the performance of a single cylinder engine of equal dimensions. Of course little differences of another nature, as, for instance, variations in the formation of the charge, in compression or the like, may explain the different action of each cylinder. These are pretty easily discovered and removed, or compensated at least. Consequently absolute exactness of the interrupter device is one of the chief requirements, and indispensable for good operation. This exactness must be obtained right in the be-

ginning of manufacture. Subsequent adjustments are not quite impossible to make, but it is very difficult to recognize where they should be applied. We have not yet devised infallible methods to investigate and correct the action of the interrupter during the operation of the engine, in fact it seems that not yet sufficient attention has been paid to this problem. The best solution is to use a separate distributor for each cylinder, this is the only way to obtain the most perfect individual adjustment. To find a compact device of this kind is well worth the efforts of the specialist designer, especially as it is just as necessary for magneto-electric generators as for all other sources of current used in direct jump spark ignition.

It would also be a very good thing to have the interrupter so designed as to be operative in both directions. At present the

(To Be Continued.)

SUMMER HINTS.

When warm weather has fairly set in we may expect to hear complaints of overheating, and it may not be amiss to point out a few factors which conduce to this state of affairs in cars which have behaved well enough during the cold weather.

Insufficient lift of the exhaust valve is a fruitful cause of the trouble referred to, because it argues a worn cam or too great a distance between the striker and the valve stem. In either case the valve is opening too late and closing too early, putting back-pressure on the engine, and retaining a portion of the burnt charge to dilute the incoming mixture and incidentally to raise its temperature. Instead of getting rid of the used gases at the earliest moment after they have done their work, they are retained in one cylinder until the piston has got some distance up on the exhaust stroke and the cylinder walls, and, consequently, the water in the jacket gets more heat units to carry away than the cooling surface of the radiator is designed to accommodate. To remedy this requires no structural alteration. A slight lengthening of the stem or striker or a new cam on the shaft, will put this right, and if the latter, do not be afraid of giving a good lift. I have been working for some time with half an inch, but this is

magneto furnishes a spark only when turning in one predetermined direction, and a change can only be made by the manufacturer, and must be ordered especially. The desired result could be obtained by making the interrupter cam reversible. Or if two cams, fit for opposite action, were placed side by side upon the shaft, the proper cam might be put in operation by shifting it to come in contact with the lever. Better still would be a magneto adapted for motion in both directions without any change at all. An arrangement of this kind would save much time and trouble, prevent many mistakes and facilitate the handling of magnetos in general.

The other sources of current used in motor practice, namely the dynamos and primary batteries, have not undergone any important changes of late, and shall be passed without discussion.

under exceptional conditions; in ordinary cases I should consider a quarter of an inch sufficient, but three-eighths better.

In many old-fashioned engines the exhaust valves will be found in a pocket, often only slightly larger in diameter than the head of the valve, and herein we get a throttling of the exhaust that a big lift is powerless to counteract. In these cases I have reseated a valve on the top edge of the pocket and fitted a valve of much greater diameter with surprising results. The old type of flat inlet valve is also an offender in this respect, and an engine which came under my observation quite recently has been improved greatly by substituting the bevel valve and seating.

Provided the body of a flat valve projects sufficiently far into the combustion space to give a perfectly free inlet to the explosive mixture, there may not be much to choose between that type and the bevel seat, though it is clear that in one case the gases are deflected some fifty degrees, and in the other at a right angle, and even so small a matter is not to be despised when we consider that it was shown by experiment recently that a fast-running engine only consumed fifty per cent of gas as compared with the piston displacement.—*The Autocar.*

A TWO-CYCLE AIR-COOLED ENGINE.

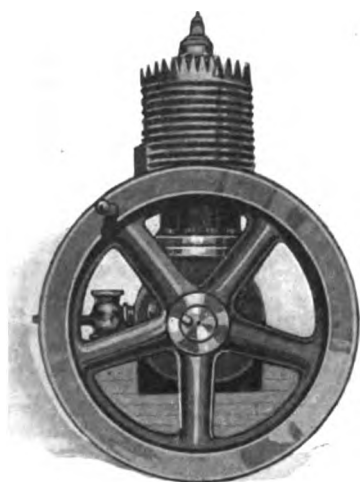

The accompanying illustration shows a two cycle, air-cooled engine, built by the Gas Engine Supply Co., Newport, Ky. The

engine has a bore of 3 inches and a stroke of 3 inches, and runs at a speed of 300 r.p.m. up. It is fitted with jump spark ignition, and has a variable speed ignition device. The cylinder head is solid, there being no packing required. The vaporizer is shown attached to the crank case, but future engines will be of the three port type, and the vaporizer will be connected direct to the cylinder. Splash lubrication is used, and there is an oil drain in the bottom of the crank case to drain off oil. Special quality cylinder castings were required to meet the conditions of air cooling. The crank shaft is hand-forged; the connecting rod is of bronze. In addition to single cylinder engines, multi-cylinder units will be built. The list price of this motor is \$65.00.

The same company is working on a water-cooled marine engine, which we expect to illustrate in a later issue. All engines built by this company are of the two cycle type.

INSTALLING GASOLINE ENGINES.

It is the usual thing for the average purchaser of a gasoline engine to hunt up some corner in which to put his engine, so as to be out of the way. Now this is one of the biggest and most expensive mistakes one can make, for as soon as some small screw gets loose in the far corner, the engine, salesman and manufacturer are consigned to a warm place, simply because the present owner has not left enough room to make any small adjustment necessary in every engine and piece of machinery; therefore it pays always to install the engine in a light, dry place, easy of access and with sufficient space all round it to handily reach all parts and to give plenty of room for turning the flywheels in starting. Wherever possible place the engine on the ground floor. If placed on an upper floor the necessary provision should be made to avoid vibration from the engine, if installed in the basement place it in the best light.

Without a good foundation an engine may be expected to give more or less trouble from vibration, as it is subjected to forces, suddenly and repeatedly exerted which produce violent reactions on the foundations.

Care should be taken to excavate down to good soil and to line the bottom with a substantial thickness of concrete, in order to form a single mass of artificial store. The foundations may then be built up of either concrete, brick or stone. Anchor plates should be extended to the bottom of the masonry and fastened so as to prevent turning while screwing up the nuts. Place gas pipes or tubes with an inside diameter twice the diameter of the bolts around them while the foundation is being built, this always allows the bolts to be adjusted and any variations between the tubes may be filled with thin cement after the engine is set.

The top of the foundation should be finished perfectly flat and level with a dressing of cement and after this is thoroughly dry the engine may be placed in position. When bolting down the engine, it is better to draw each nut down a little at a time until all are tight and thus avoid straining the engine bed. After the nuts are drawn tight, if the crank turns unreasonably hard without loosening the main bearing caps, it may indicate an uneven foundation causing a strain in the engine bed casting. When setting up

large engines, especial care must be taken to avoid straining the bed castings. Foundations hung from an upper floor, or built upon it, should be placed as close to the wall as possible. For the smaller sizes of engines it is a good plan to lay wooden beams on the top of the foundations and then to place the engine on the top of them so that when the engine frame is bolted down it beds itself into the timber. The timber cap often saves an annoying vibration when it can be overcome in no other way.

All the connections should be as short and as free from turns as possible, and no mistake can be made by having plenty of unions so as to disconnect with ease. The gasoline tank should be set as near to the engine as is convenient and with the top of the tank preferably not more than a foot or two below the base of the engine. In cases where the gasoline tank must be set from forty to fifty feet away it is necessary to place a check valve in the suction pipe near the tank, both suction and overflow pipes must have a gradual rise all the way from the tank to the pump and should be as straight as possible, so as to avoid air traps which prevent a steady flow of gasoline. It is most essential to clean thoroughly all pipes and fittings before putting together, by hammering lightly to loosen any scale and washing out with gasoline, as solid matter of this nature may be responsible for some of the simple but hard to get at troubles "common" to gasoline engines. Shellac is best for joints in gasoline piping, but when this can not be obtained common laundry soap will answer the purpose just about as well. In some cases it will be found advisable to use gravity feed instead of a pump and the foregoing remarks are applicable with the exception of the tank must be so arranged that its lowest point is slightly above the generator valve.

The exhaust pipe must be of full size, free from turns and as short as possible, the shorter it is the better and the more economical the engine will run. It will be found advisable to place the muffler as close to the engine as possible, setting it carefully so as to avoid any strain on the valve casting. Keep both muffler and exhaust piping away from combustible material and never turn the exhaust into any chimney or flue.

It is desirable, although not necessary, to draw air from outside the building, as it prevents noise of suction; this noise is overcome, however, on most of the modern en-

gines by drawing the air directly into the valve from the inside of the bed casting. When the pipe is placed outside it is necessary to protect the outer end from dust, shavings and refuse,

There are two general methods of supplying this water, the first being that of the cooling tank, commonly used with small engines. For convenience in piping the tank should be slightly elevated and both pipes, having as few bends as possible, should slope from the tank to the engine, a valve being placed in the bottom pipe near the tank. By using a circulating pump, fitted to the engine or shaft, water may be used from an underground cistern or tank. The other method is to use, when available, a continuous stream of cooling water from the city water works or other source. When city water is used it is a good plan to have a break and a funnel inserted in the drain pipe so that the current of water flowing through the cylinder jacket may be seen. For making joints in water pipes either thick paint, lead or graphite may be used with almost equal success. It may be well to place particular emphasis on the fact that it will pay to get into the habit of always shutting off the water at the tank and draining the cylinder every time the engine is stopped—not necessary to do it in summer, but absolutely necessary in winter—as a fair percentage of gasoline users know to their cost.—*The Canadian Thresherman.*

COST OF OPERATION.

"What will it cost?" and "What will it save?" are the questions prospective engine buyers are continually asking. Here is the way one manufacturer answers them in a recent catalogue:

"The little outfit will easily take the place of four men. At the average price of \$1.50 per day, four men's wages would amount to \$6.00 per day, while the cost to operate the little 1½ H. P. outfit would not exceed 25 cents per day. Here is a saving of \$5.75 that is well worth your consideration. The little outfit is portable, complete on one base and can be moved anywhere around the farm by one man and is always ready to start. At this rate, it would not take long to pay for this outfit if only used a short time each day, and it can be used with the same efficiency and satisfaction in any capacity where reliable and efficient power is required."

GAS ENGINE SOUNDS.

The successful running of the gas engine produces certain sounds that should be familiar to everyone who has charge or who intends to have the care of one. First of all and most noticeable of these is the sound made by the exhaust gases. If this is not muffled the sound produced is very similar to the report of a rifle or pistol shot on the smaller-sized engines, and heavier according to the size of the engine. On an engine that has a hit-and-miss governor the exhaust reports are irregular, unless the engine is running under a full load. The exhaust reports being due to the unused pressure in the cylinder when the piston has finished its working stroke, they can occur only when the governor has admitted a charge and it is exploded. When the engine is running light, therefore, and a charge is needed only every third or fourth revolution to drive the load, the exhaust reports will occur irregular and according to the charges admitted. But when the load is heavy and constant, so that the engine needs every charge it can get to carry its load, then the exhaust reports become regular. In engines of the throttling governor type the exhaust reports are supposed to be regular, whether on heavy or light load, because the governor is designed to admit a light or heavy charge at each admission stroke according to the load. That is the governor controls the size of the charge and allows a full charge when necessary and only half or a fourth of a charge when the momentum is sufficient to maintain a constant speed without a full charge. The character of the exhaust reports may vary, noticeably, being loud, medium or mild, according to the size of the charge admitted. On automobile and marine motors, which are not automatically governed but are controlled by the operator by means of the admission valve and the spark shifter, the exhaust reports are regular, but depend entirely upon the speed of the motor as to the frequency or rapidity of their successions. It will, therefore, be seen that the regularity or irregularity of the exhaust reports and their character depends naturally on the type of governor that the engine is fitted with. But there are a number of abnormal conditions that effect the regularity or irregularity of the exhaust reports. A gummy, dirty or

worn condition of the working parts of the governor may prevent it from admitting the charges properly, and exhaust reports will be affected accordingly.

The igniting apparatus may not be in good working order and fail to fire all the charges admitted by the governor, and, of course, there can be no exhaust report unless the charge taken into the cylinder is ignited and exploded. The character of the exhaust reports are often effected by a leaky exhaust valve, part of the force of explosion escaping the instant ignition occurs and continues to escape until the valve is lifted by the cam to effect the relief or the pressure within the cylinder. This leak may be sufficient to cause a very noticeable puff just prior to the loud exhaust report. The failure of the admission valve to admit charges to the engine properly will effect the number of exhaust reports. The exhaust sounds from the gasoline engine are an excellent guide to the successful running of an engine, if properly understood. It is one of the features of the running of the engine that is carefully studied by all successful gas engineers. They learn to locate abnormalities by noting the difference in the character or number of the exhaust sounds. The normal sounds become so familiar to the trained ear that any abnormal one is instantly noticed and the cause of it looked for.

Another natural sound in all stationary gasoline engines is the sound of the air rushing into the mouth of the pipe as the engine takes its charge. This is the inhalation sound and occurs just before the exhaust report. When the engine is running at full speed the exhaust report follows it so closely that the two sounds really appear as a part of each other. A pair of sounds that go together, and the operator soon learns to know that the exhaust report must follow each inhalation or something is wrong. The inhalation report is not a pistol shot report, but rather a whistling sound very similar to the sound made by the mouth when the lips and teeth are slightly apart, and a forced inhalation of air is taken into the lungs through mouth instead of nose. It is an inhalation or suction noise. Its regularity also depends on the type of governor used on the engine and occurs only when the governor permits the opening of

the receiving or intake valve. Anything that obstructs or partially stops the air passages to the engine will effect the character of the inhalation sound. Some manufacturers equip the air pipe to their engines with some kind of a shut off valve, so that the air may be throttled or have an easy flow at the will of the operator. It is in some instances advantageous to cut down the supply of air and thereby make a stronger pull on the fuel supply and vice versa. The manipulation of this valve in the air pipe will change the character of the inhalation

It is surprising how some operators allow themselves to become accustomed to unnatural sounds until they actually regard them as natural. It is so easy to say when an unnatural sound is noticed, "I will look into it and fix it to-narrow." And when tomorrow comes it is put off again until it becomes a natural sound to the ear of the operator if the engine continues to run long enough. The writer was called to see a gas engine recently that was giving trouble. The man in charge could start it, but could not get the power out of it that he formerly did. We asked him to start it up so that we might judge from the running of it what might be the cause of the trouble. The first thing that attracted my attention when it started was the intense racket and clatter that apparently came from the boxes at both ends of the pitman or connecting rod. This abnormal clatter was so very marked that I could scarcely hear any of the normal

sounds. And yet the man in charge had become so accustomed to it that he did not consider it abnormal or anything that needed his serious attention. I told him that if I had charge of that engine I would give my whole attention to that clatter until I had it completely obliterated. Then it would give one a much better chance to locate other troubles that might exist. And one is almost always safe in concluding that they exist where he finds an engine in the hands of an operator who will allow it to get into a condition that the clatter of the connecting rod is the most prominent sound about the engine. In addition to this we found a badly worn exhaust cam roller, and starting lever roller, and that the spark was made too late and the tension on the receiving valve spring was away too low. All of these things together made a very ineffective running engine. Either one of them alone was sufficient to affect it seriously. The unnatural sounds in this engine were very much in the majority. To keep down these unnatural sounds one must acquaint himself thoroughly with the natural ones, and then constantly keep an ear open for the unnatural, and the moment they occur give them immediate attention. "You have to *show* the fellow from Missouri" before he will believe, but the successful gas or gasoline engineer needs only to hear to become a firm believer that something is wrong. The sense of hearing is the gas engineer's guide. The sight confirms this suspicious guide.—*Canadian Implement and Vehicle Trade.*

BOOK REVIEWS.

Electricians' Handy Book, by Prof. T. O'Connor Sloane, A. M., E. M., Ph. D., red leather, gilt edges, pocketbook style, 761 pages, $6\frac{1}{2} \times 4\frac{1}{2}$, 556 illustrations and diagrams; price \$3.50.

In compiling a handbook of any kind it is not so much a matter of the author's decision as to what to include in the book as it is what he shall leave out. A subject so complex and so little understood as electricity offers opportunity for a very wise selection of what to omit from an electrical handbook. In the book under review it is surprising that Prof. Sloane has been able to include as much as he has, and while he has no doubt omitted some things which might have been included, he has made a good selection.

The book is not a mere collection of tables and statistics, nor is it a collection of catalogues. Beginning with a chapter on mathematics, it contains chapters on electric quantity and current, Ohm's law, primary and storage batteries, magnets, induction, generators, motors, management and care of generators and motors, electrical instruments, arc and incandescent lamps, etc.

Perhaps the best recommendation of the book may be the statement of the fact that only a few days before its receipt, the reviewer was endeavoring to learn of a handbook for a young electrician, but was unable to discover one. When the Handy Book arrived it proved to be just what we were looking for.

A GAS POWER PLANT.

The Engineering Record of July 15 contains an article describing a gas engine and producer gas plant at the works of the Atha Tool Company, Newark, N. J.

A fire-proof power building contains the engine, etc. A coal siding parallels one side of the power building, delivering coal to an elevator boot beneath, whence it is transferred to the second or charging floor of the producer house. The engine room is about 20 x 57 feet, with 16 feet in the clear and an 8-foot basement; the producer house is 33 x 42 feet in size, with two 16-foot stories.

There are now three generating units of 75 kw. each, and a fourth of 100 kw. capacity is being added, so that the total ca-

capacity will be about 500 H. P. Three-cylinder vertical Westinghouse gas engines are used. A six-cell storage battery and a 1 H. P. motor generator unit furnish duplicate sources of ignition current.

The gas is generated by a pair of Loomis-Pettibone producers. Air and water gas are generated at alternate intervals, and the water gas is sent to the holder from a vertical net scrubber, which contains eight layers of broken stone, coke and excelsior. The air gas, or producer gas, goes through a dry scrubber in addition to the wet scrubber. Two men are sufficient to handle each section of the power house, except in weekly cleaning of the gas generators.

THE "WONDER" GASOLINE MOTOR.

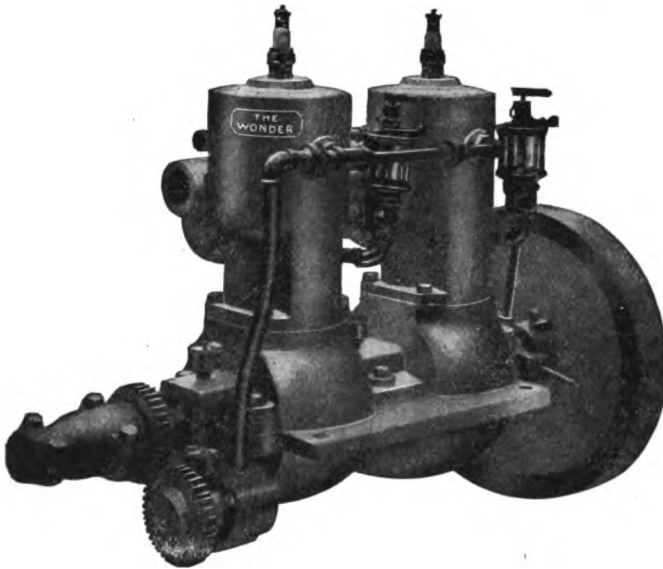

The accompanying illustration shows the "Wonder" two-cylinder engine, built by the R. M. Cornwell Company, Syracuse, N. Y.

The cylinders are water jacketed to a point below the combustion chamber, and surrounding the exhaust port, which is of vital importance, as the bearing surface will heat and pit at this point if not adequately cooled. As the efficiency of any engine depends on the scavenging of the cylinder of burnt gases and proper inlet of fresh, the ports have been so proportioned as to get

the best result at all speeds which the occasion demands. The ports are provided with ample bridges which prevent unequal wear by the rings at these points.

The head is cast integral and does away with the packing with gaskets, which is bound to occur with detachable heads. They are bored and reamed to gauge, and holes for crank case bolts are drilled with jigs so that all are interchangeable.

The crank base is very compact, and just allows for clearance of working parts; this

obtains very high compression of incoming charge of gas and insures its being forced into the cylinder at high velocity and thoroughly cleaning out the previously exploded burnt gas, and obtaining the highest compression possible. The bearings are formed by forcing bronze brushes into standard reamed holes, which allows of renewal without disturbing the alignment of shaft,

which is impossible by the cheaper method of babbitting in rough cast holes.

Jump spark ignition is used.

In single-cylinder types a unit of $1\frac{1}{2}$ H. P. is built, and in double cylinder, 3 H. P.; $2\frac{1}{2}$ to 7 H. P. single, double and triple units are under way. A stationary outfit of $1\frac{1}{2}$ H. P. is also built by this company.

A QUICK REPAIR.

We had a quick rush job to get out in our factory some time ago, and, as is usually the case, a break in the gas engine occurred just at the most inconvenient time. A piston packing ring broke, and, as our engine was overloaded, making it necessary to have it in the best condition to do the work, we had to repair it at once. We had no extra rings, and it would have taken some time to get one made and delivered to us. Had it not been a gas engine it could probably have been packed with regular steam packing, but the ring had to be made of metal to stand the heat.

One of our men said he could repair it, so he took the broken ring and made an impression of it in some clay sand. He then melted some scrap zinc and poured it in the mold. The result was a shiny ring that required very little polishing to make it

smooth. We used great care in springing this on the piston, and when finished the job was a good one and only required two hours' time. We ran with this ring until the end of the week.

This same engine at one time had a pound that seemed to be located in different places. We had several experienced men to look at it, but the knock could not be located. There was no lost motion in the bearings or fly wheel, the piston was a good fit and nothing could be found which was wrong. We were about to give up in despair when a little ridge of oil was noticed working at the edge of the engine bed at each impulse the engine received, showing that it was loose on its foundation. I had never heard of this causing a knock, but when tightened the knock disappeared and was heard no more. —*The Practical Engineer.*

INDUSTRIAL ITEMS.

The J. B. Hicks Gas Motor Company, Waycross, Ga., is erecting a plant for the manufacture of gas engines and automobiles.

B. J. Monradyan Bros., Galata, Constantinople, Turkey, are reported as seeking a line of American gasoline engines. Correspondence in French.

A Rambler touring car was recently tested over a 500-mile trip in Utah. The consumption of gasoline was reported to be $30\frac{1}{2}$ gallons, which cost \$7.50, or $1\frac{1}{2}$ cent a mile.

Mr. William H. Spiller, formerly at Aurora, Ill., has been appointed manager and advertising manager of the Weber Gas and Gasoline Engine Company, Kansas City, Missouri.

The Johnston Oil Engine Company, Toronto, has been incorporated with a capital of \$250,000, to manufacture engines and motors used for the production of power, oil, gas, electricity, etc.

A prominent English gas engine manufacturer is reported to have said recently that gas engines governing on the hit-and-miss plan are generally 20 per cent less economical at half load than at full load.

A feature of the Ohio State Fair, at Columbus, O., September 4 to 8, is to be exhibitions with an "air ship" by Roy Krabenshue, of Toledo, O. Mr. Krabenshue has made some very successful trips at the St. Louis Exposition, and also at Toledo, O. A small gasoline motor furnishes the power.

The Municipal Council of Paris recently ordered a gasoline street cleaner and water sprinkler. Recently tests were made with a gasoline street cleaner, and it was found that the vehicle cleaned 17,950 square yards in one hour, which is as much as that cleaned by four horse-drawn cleaners in the same length of time.

It is said that British submarine boats have covered 30,000 miles under their gasoline engines, and, with the exception of a small flash in an early boat, no explosion has ever occurred until the "A 5" accident recently. In this case the accident was due to leakage from a badly packed gland on a gasoline pump, the gland being screwed down metal to metal.

The F. W. Horstmann Company, East Newark, N. J., have in operation in their machine shop a 20 H. P. gas engine and suction gas producer, built by Dr. Oskar Nagel, 90 Wall street, New York City. The plant is working under a guarantee of 1 B. H. P. per hour from 1¼ lbs. of anthracite (pea) coal on full load, 1 1-3 lbs. on ¾ load and 1½ lbs. on half load.

The Celina Gas Engine Works, Celina, O., started its factory August 21 manufacturing a line of gas and gasoline engines up to 50 H. P. Mr. O. F. Good, formerly of the Good Gas Engine Company, Dayton, O., is general manager of the company, and the engines to be built will be under the Good patents. Machinery and supply catalogues are desired, as the company will put in new tools.

The official tests of a 1,000 H. P. Mond gas plant at Heysham Harbor, England, showed that the gas produced from one pound of fuel contained 9,720 B. T. U., the quality of the gas varying in different tests from 185.6 to 158.3 B. T. U. per cubic foot. Two producers, with their accessories, are in use, with four gas engines of 250 B. H. P. each. Bituminous coal was used, and the amount required amounted at full load to 1.28 pounds per B. H. P. Two men suffice to look after the whole plant.

Mr. Halbert P. Gillette, M. Am. Soc., and Mr. Geo. H. Gibson, A. M. Am. Inst. E. E., J. M. Am. Soc. M. E., formerly manager of publicity for the International Steam Pump Company, manager of the advertising department of the B. F. Sturtevant Company, and editor of the Westinghouse Com-

pany's publishing department, have formed a partnership as "advertising engineers," under the name of the Geo. H. Gibson Company, with offices in the Park Row Building, New York City. They undertake to conduct a firm's advertising in the same manner as would a department in the firm's own offices, and are not advertising agents in the usual sense of the term, as they receive no commissions, rendering only service and leaving the actual purchasing of space and printed matter in the client's hands.

Vice President Mohler, of the Union Pacific Railroad, recently made the following statement regarding the use of motor cars on that road:

"Mr. Harriman is fully convinced as to the necessity and future use of the motor cars, and it is simply a question of how fast we can perfect them. We don't expect to make the first few absolutely perfect, but the imperfections will be overcome rapidly. The car already constructed has run over 5,000 miles and has demonstrated its capacity in that direction.

"There are over 200 branch lines on Southern roads over which trains are run simply because the tracks are there and not because there is any profit derived therefrom. With the motor car the cost of service will be so cheapened that these lines can be run with profit."

The Automobile Club of Belgium every year promotes the Circuit des Ardennes. According to the rules it is a continuous race without stopping places, and the distance covered must be at least 342 miles. Each manufacturer was this year permitted to enter not to exceed four cars, and each car must have a muffler and exhaust not directed toward the ground, to prevent raising dust. Five laps were made in the race, and contestants who did not cover the first four laps, about 300 miles, in less than eight hours, were compelled to withdraw, to make the last lap as clear as possible for the remaining contestants.

The course this year measured 373 miles. Cars were started at intervals of three minutes. An 85 H. P. Darracq racer, driven by Hemery, won the race in five hours, fifty-eight minutes and thirty-two and one-fifth seconds, an average speed of sixty-two and two-tenth miles per hour. A 120 H. P. Panhard finished six minutes and fifty-two seconds later.

TRADE PUBLICATIONS.

Catalogue No. 17, from Byrne, Kingston & Co., Kokomo, Ind., gives a complete list of Kingston carbureters, spark plugs, spark coils, etc.

"Producer Gas Fuel Installations" is the title of a new booklet from the Wile Power Gas Company, Rochester, N. Y. The advantages, uses, method of manufacture and cost of producer gas are covered in detail.

B. G. Gilbough, 416 Commercial National Bank Building, Chicago, Ill., is sending out circulars of a primary spark plug, which has but three moving parts, which operate in unison in a perpendicular direction, and which move only from 1-16 to 1-8 of an inch.

Stoddard gas and gasoline engines are described in a new catalogue from the Creamery Package Manufacturing Company, 184 East Kinzie street, Chicago, Ill. These engines are all four-cycle type. The horizontal units range from 3 to 40 H. P., and the vertical from 2½ to 10 H. P.

W. S. Sheppard, 21 Lawrence street, Newark, N. J., gives, in a new booklet, a description of some of the difficulties experienced in securing satisfactory gas engine oils. He gave the matter consideration and tells of the results of his experiments in bringing out his "Ideal" oils.

The Thurston Manufacturing Company, 356 East Fifty-seventh street, Chicago, describe a new magnetic flash plug in a circular from them. This plug is about the same size as the ordinary spark plug. Intended to work in a perpendicular position, it will still operate in a position almost horizontal.

We have received from the Polytechnic Institute, of Brooklyn, a circular of the evening courses in transportation for 1905-'06. Among the subjects to be considered will be "The Gas Engine for Central Station Service" and "The Steam Turbine for Central Station Service; Its Sensibility as Compared With the Gas Engine." Charles A. Green is the registrar, and inquiries may be addressed to him, in care of the institute.

One of the most elaborate catalogues to reach us last month was from the De La Vergne Machine Company, New York, and relates to the two-cycle Koerting gas en-

gines. It is printed in two colors and has double covers. It contains complete sectional views and descriptions of the method of operation of these engines. It has a discussion of blast furnace gas, as well as numerous tables relating to producer gas, calorific values, etc., and, all in all, it is a very complete and interesting catalogue.

The attractive character of the illustrations used in a folder issued by the A. Streit Machine Company, 1108 Harrison avenue, Cincinnati, O., adds very much to the effectiveness of the reading matter. A 5 x 5 15-16 H. P. opposed motor and a 25 H. P. four-cylinder vertical motor are shown, and the detail of the engines is brought out by an intensely black background. A list of dimensions, etc., completes the circular and gives the prospective purchaser full information in a concise way.

We have received from the Burt Manufacturing Company, 260 Main street, Akron, O., a very handsome catalogue, which describes in detail the various oil filters and exhaust heads manufactured by this company.

It illustrates and describes the "Cross," "American," and "Warden" oil filters, the "American" oil filtering system, and the "Burt" and "Standard" exhaust heads.

The valuable information which it contains in reference to the filtering of oils makes it a valuable work of reference.

It also describes fully the "Unit Type" of oil filters, which is used in connection with the American oil filtering system.

The Morgan Construction Company, 40 Exchange Place, New York, N. Y., are sending out a new catalogue of their continuous gas producers with automatic feed. Much instructive information is given regarding the process itself, and the possibilities of this modern method of securing the greatest heat value of fuel. The high degree of perfection attained by these producers is shown in some tests made by Robert W. Hunt & Co., in which an average efficiency of 92 per cent was attained. The generation of gas from bituminous coal for power service is touched on, and this subject will be covered more thoroughly in a later catalogue.

THE GAS ENGINE.

STATIONARY—AUTOMOBILE—MARINE.

PUBLISHED MONTHLY BY

The Gas Engine Publishing Co.

Blymyer Building, Cincinnati, Ohio.

ADVERTISING RATES ON APPLICATION. Address All Communications to the Company.

Entered at the Postoffice at Cincinnati, Ohio, as Second Class Matter Feb. 20, 1899.

VOL. VII.

OCTOBER, 1905.

No. 10.

Domestic Subscriptions, \$1.00 per Annum.

Single Copies, 10 cents.

Foreign, \$1.50 per Annum.

Owing to the introduction of suction gas plants, the gas companies of England have been brought face to face with the necessity of doing something to retain their present users of gas for power service. Not only this, they have discovered that there was a latent demand for a cheap fuel for gas engine power service, and in order to meet the new conditions they have, in numerous instances, reduced their prices for gas for power service. Much discussion has been going on among the gas companies as to "what was the lowest cost above the expense of manufacture per 1,000 cubic feet at which they could afford to supply gas for power purposes to add to the consumption in the summer and the daytime, when a large part of the capital is, to a certain extent, idle." Or, as Mr. Dugald Clerk put it, "what is the highest price at which they can supply to keep competitors out of this line of business?" The trend of opinion seems to be that the highest price is about 35 cents per 1,000 cubic feet. Some of the companies have even gone below this, one rate being as low as 24 cents. Of course, not all of this gas has a high heat value, and for an accurate basis of comparison this should be taken into consideration. Our point is, however, that the British gas companies are waking up to the fact that the gas engine is a possible consumer of a considerable quantity of gas.

Some four years ago there appeared in the columns of THE GAS ENGINE an article on the standardization of gas engine nomenclature, in which there were collected and explained many of the terms used in connection with gas and gasoline engines. The fact that some of these terms were synonymous, that others (often used synonymously) really had different meanings, that the meanings of certain terms depended on the person using them, were variously pointed out. The term "horse power," together

with its differentiated meanings when coupled with the adjectives "actual," "brake," "effective," "developed," "indicated," etc., has perhaps been the cause of more disputes between the manufacturers and the purchasers of engines than has any other term used in gas engine work. Unscrupulous salesmen have often imposed on ignorant purchasers, and the careless use of the term horsepower has, as above stated, caused many a dispute and a number of law suits. In another column will be found a review of a discussion which has been taking place in Germany recently along the line of methods of determining the distribution of the internal resistance of gas and gasoline engines. Mr. Rudolph Diesel proposes several new terms, or rather several distinctive meanings for old terms, which will, in reality, convey some definite meaning, and which will eliminate errors due to a misunderstanding of terms, or the incorrect use of terms. The gas engine nomenclature of today is exceedingly varied, and it is to be regretted that we can not dispense with some of the terms for the sake of simplicity. However, this does not seem possible, and anything that can be done to make these terms mean some definite thing should be welcomed for the sake of clearness of meaning.

A rather unusual case of pipe corrosion came to our attention recently. An engine was installed with one of the usual types of gas pots for the exhaust. This pot was buried in ground containing a very large quantity of cinders. Some time after the plant was placed in operation it was found that the exhaust pipe leaked somewhere. On digging up the ground along the exhaust pipe to the exhaust pot, it was found that the pipe and pot had been corroded by some chemical in the cinders. In fact, the exhaust pipe had been eaten through in certain places.

AN INDIANA GAS PRODUCER PLANT

By EDEN E. EATON, E.E.

When the Enterprise Stove Company, of Vincennes, Ind., which was destroyed by fire in May, 1902, was reorganized into what is now known as the Star Shovel and Range Company, they concluded to put up a modern plant for the purpose of manufacturing their goods beyond the competition of all others, regardless of first cost of installation. This was the idea of Mr. George Thompson, General Manager, Secretary and Treasurer of the company.

The plant to be installed required but 100 H. P. and was located in a district where coal is plentiful at \$1.80 per ton for two-inch nut coal, or 50 cents a ton for slack. Mr. Henry Swartz, chief engineer of the city water works, advised Mr. Thompson to investigate gas power.

The jig was up, gas power was it, regardless of first cost of installation, which was to be gained back by the saving in the coal pile, the coal strikes to contend with, and the future of probable city trouble with the large smoke stack, as the city is rapidly becoming an immediate metropolis. Of course, a modern steam plant of the same horse power could have been put up complete for the price of the gas engine alone, but it was very well understood that with the best of steam engines, with the most modern auxiliary appliances, even in large units, and with skilled men also, that 2½ to 3 pounds of coal per H. P. hour was considered good, regardless of the expense of maintaining such a plant with its dangers.

It was also noted that it was safe to invest for every 1 per cent of economy in consumption of coal at \$1 per ton \$250, at \$2 per ton \$500, at \$3 per ton \$750, per producer gasifying five tons per day.

There was some trouble in finding a company that would guarantee their engine to run upon the gas made from soft coal at that time. In fact, several of the leading gas engine companies that are today (just two years later) pushing their engines for producer gas, were asked to bid and refused. The first engine picked out, even after the foundation was built for it, the company backed out and another foundation was made to suit another make of engine, which was installed in January, 1904.

Now, it might seem foolish to undertake such a proposition in this country, where coal is so cheap, to install such an expensive plant for the use of only 100 H. P. But let me draw your attention to the fact that a great deal of heat was needed for the furnaces, to heat the shovel steel before it could be stamped or welded. This was taken advantage of by the producer also. As the cry is now "preserve the forests," it will be only a question of time until the cry will be to "preserve the coal veins," which should be done. If it is not done, the day may come when coal will be 31 cents a pound and scarce at that, as it is in some parts of Europe today, where the producer gas power was first originated.

At those prices for fuel how can Europe ever expect to compete with America upon the power question, if she will start in time to preserve the coal veins, which she should do? Anyone familiar with producer gas power can not help but think every time he looks at a steamer, locomotive, stationary boiler stack, or even the chimney of our own homes, the sin that is going on every day, from the waste of useful gas. Why all over earth that these continued streams of smoke need is a little adjustment of steam or air mixed with them, and they will give about seven times as much power and heat as they do with the present method, and at the same time cremate all that dirty soot and sulphur, etc., that is every day disfiguring and eating away valuable property, such as large steel bridges and viaducts, etc. There is no doubt but what the day is not far off when the cooking and heating stoves will have their fire boxes so arranged that the fuel will all be gasified, and then burn therein, even through the rural district, and in the more modern houses in the cities, where the heating system is centralized in the basement.

The writer knows of an inventor who is working upon the producer gas stove for the rural district.

England is installing such a system today to furnish poor producer gas for power, heating and cooking purposes. As the older methods of making gas are too expensive for this use, poor producer gas plants can, without a doubt, be classed as one of the seven wonders of the world.

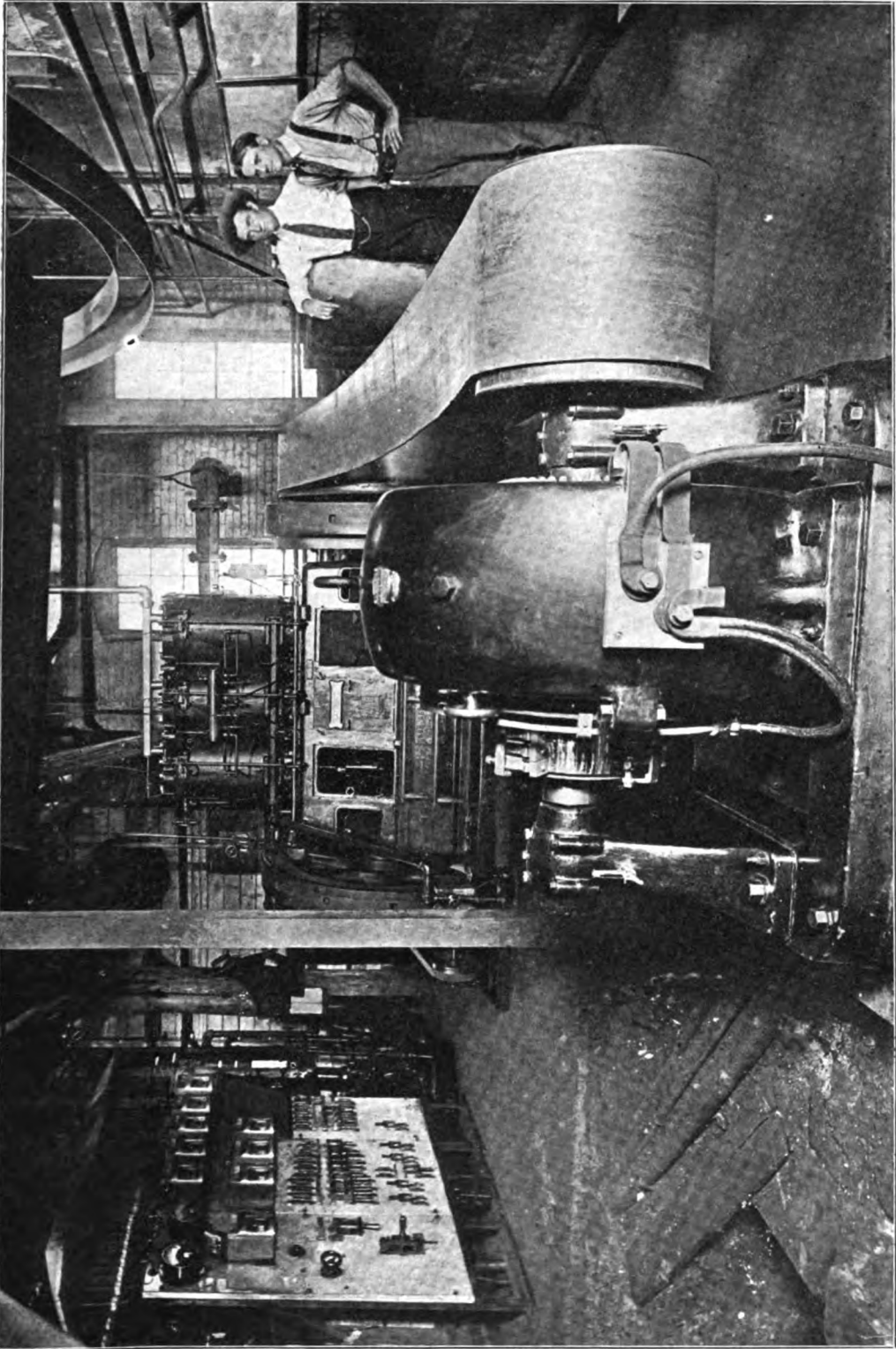

100 H. P. GAS ENGINE AND GENERATOR AT VINCENNES, IND.

During the World's Fair at St. Louis there were a great many visitors that came to see the plant run, and most of them were gas engine men, or prospective buyers. Some of the largest gas engine and producer companies in the world had their experts make notes of it, and I picked up a great deal of information from them. It was rather interesting to see the foreigners look and talk. One English expert from a gas engine and producer works (so his card read) asked me if I had any trouble in getting started in the morning. When I told him "No," he said "It was a wonder, as over home they often had trouble that way."

This plant was claimed by the installers at the time, January, 1904, to be the first plant in the United States where a gas engine was successfully run to furnish power from gas made of soft coal, outside of the factory test, as the tar was too great a bother.

We are now able to purify the gas which we use for the engine, so that we can run thirty days or longer without being bothered with tar on the governor, and, therefore, get good regulation in speed, at the same time making it safe to leave the engine with its governor not liable to stick. The igniters are cleaned every morning before starting, although it is not necessary. The sulphur is also taken care of, but the rest of the by-products are let go, as in such a small plant it would not pay to put in the proper appliances for the recovery of same. The ashes are taken away from the producer once a week, on Sunday. The attendant must study the conditions as they come along for there are some differences when the atmosphere changes—real cold weather and warm weather—in the operating of the producer warm weather being preferred by me for economy in operating the plant.

When I started in the plant I did not know the first principle of a gas producer, but had the advantage of knowing something about the electrical part, steam and gas engine end, having worked and studied at them for several years. But as a steam engineer should know about the boiler room, so it is important that a gas engineer know about the producer room, especially in a small plant. Most people think that a gas engine is not to be depended upon to run at all times; let them also remember that at least 150 families depend upon their daily bread, from this engine running, and

if it did not run it would be hard to keep men to work here.

To show another important part this engine does, and to try and convince those that think a gas engine can not be trusted where life is at stake or great loss of property, if it should stop operation, such as coal mine hoisting engine, etc., unless there is a duplicate, anyone who knows anything about foundry practice knows that when a heat is started that the fan that furnishes the draft for melting the iron in the cupalo must not be allowed to stop, as the iron would chill in the cupalo and be very expensive and troublesome to all concerned.

We have never had to let this heat fail on account of the gas engine or producer but once, and that was on account of the blow-off pipe upon the steam boiler blowing off, as not much attention was paid to the boiler.

The engine is a Nash three-cylinder, vertical, throttling governor, four-cycle engine, built for city gas, etc., for 125 H. P., and is guaranteed to give 100 H. P. at 250 r.p.m. on producer gas from soft coal, where the B. T. U. per cubic feet equals 150, which our gas showed in the test with the best soft coal we could find here, which is from Harrisburg, Ill.

The water for cooling the cylinders is pumped out of a cistern and returned to same by a rotary pump. This pump has a bad feature, and that is, it is run by a belt off the engine shaft, like an exciter to an alternating current dynamo. If the belt was to break or come off while the engineer was out, the engine would soon ruin itself from over-heating. The pump should have been mechanically fastened to the engine or run with a sprocket chain. The water from the roof, when it rains, runs into the cistern, also part of the other drains from the producer in which the top is a water cooled one, and its drain runs to the gasometer, thence to the overflow to the cistern, keeping up all evaporation of water in the gasometer. The condensed steam from the Buffalo steam-heating system also runs into this cistern. The engine also has an attachment for water works water, for cooling the cylinders if needed. For starting the engine an air pump is used to compress the air in the reservoir to 80 pounds. The compression is reduced in all the cylinders by simply moving a lever which also cuts out the third cylinder as a gas engine and allows it to be used as an air engine until

the engine is started, the other two cylinders being used as gas engines to start up. When under headway the lever is thrown over, and the third cylinder is cut in as a gas engine, and the compression increased in all the cylinders. The electric spark is constant in all cylinders at all times. The engine is belted to the producer room line shaft, and the machinery of it includes the Bildt patent automatic coal feeding device, the fans for purifying the gas, a water pump for pumping drinking water, and the coal hoisting elevator. The circulating water pump for cooling the cylinder is belted to the opposite side of the engine. If we had a clutch pulley on the shaft it could be cut out until after the engine was started, and the load applied afterwards, and it would also come in handy for several other things that have happened in practice.

It is claimed that the producer room line shaft, when everything is working, including the coal elevator, consumes 20 H. P. but I hardly think so. The coal elevator has a clutch pulley of its own, and it is claimed that 7 H. P. is required to run it when hoisting coal. It is used when the load is at the lightest upon the engine, if possible. The engine load is variable, owing to the starting and stopping of the different motors through the factory. It is claimed 13 H. P. is required to drive the rest of the producer machinery, making about 13 H. P. that the engine has upon it when started with air. Once the elevator belt came off from over-load, feeding of coal too fast to it, and broke the clutch pulley, so we had to leave it in gear for a few days until we could send and get parts needed. We had then about a 20 H. P. load to start off with, which was done all right. The generator is a Northern 250 volts, 300 amp. 4 pole, and 10 per cent over compounded to give better regulation in voltage, which it does, and is driven by a belt from the prime mover, the gas engine, at 750 r.p.m. About \$1,000 was saved by not having it directly connected, but I do not think anything was gained by it. The switch board is a three-panel white marble board, 7 by 8 inches, and from it nearly every motor and circuit throughout the entire factory is controlled, by a separate switch of its own, and enclosed fuses, to comply with the rules adopted by the National Board of Fire Underwriters. Also, every department is represented upon it by a nickel-plated switch

board type watt meter. There is also a master meter for the main line of 300 amp. capacity. The volt and amper meter are of the Weston make. A circuit breaker and ground detector is also included. As the engine is ignited from storage batteries, they are also connected to the switch board in such a way that while one set is being charged the other is in use. There is also an attachment by which the spark can be taken directly off of the generator itself in such a way as not to make a ground upon the dynamo after it has been built up and ready to furnish the current. The gas testing tube is also lit by electricity, saving a great many matches. There is 9 4-pole shunt wound, Northern 220 volt, D. C. motor with switches and fuse blocks of their own, and also rheostats with automatic switches for overload and under, including a 10 H. P. in pattern room, rattling room 15 H. P., range department 10 H. P., mounting and nickel-plating department 15 H. P., machine shop 15 H. P., shovel department three 20 H. P., and a cupalo fan 35 H. P. All of those motors are installed in such places as to represent too large an area to be reached by any other source, common in practice now, and every line shaft driven by these motors has self-oiling, roller bearings. There are eight enclosed arc lamps and 125 incandescents. It can be readily seen that if all this power was applied at once, that it would take two such units as we have to drive them, but such was figured not to be the case for a while, but, should it be, the engineer being familiar with what motor to dump at certain times of the day, it is perfectly under his control, and, should the gas get a little weak, you would not have to depend upon some foreman to do it in his department, to throw out a clutch pulley with the belt of the other system, and maybe have the engine choked down as a gas engine acts very much like an induction motor when over-loaded.

The producer room includes a 300 H. P. R. D. Wood & Co. pressure anthracite coal producer, which we use bituminous coal in with the Bildt patent continuous automatic feed device. It is not their water seal bottom type, but it has the crank and gearing to turn the complete round grate to lower the bed of ashes. The top is water cooled. The gas main for the furnaces runs out on one side, under the concrete flooring

through the engine room to the gas furnaces in the shovel department.

The producer room contains, down stairs, the economizer, the boiler, the ash pit of the producer, the wash box, the bottom part of the scrubber, and the different parts of the water seals to take out tar, etc. A small 35 H. P. vertical boiler is used in the summer time, 15 H. P. of it is required to furnish steam and air for the 300 H. P. pressure producer, and the other 10 H. P. is used for operating two steam elevators, one for the cupalo, and the other for the ware-room in the cellar. Also, a little steam is used in the nickel-plating room and shovel department for steaming handles, before berding them, etc. For the winter time, there is a 65 H. P. horizontal boiler, which was used in the old factory. It is now used also to run a Buffalo hot air heater for the factory in the winter.

The advantage of having this fan driven by a steam engine is that it can be run all night by the night watchman in cold weather, or started up in the morning in time to warm up things without waiting till the gas engine is started. The steam elevators were also put in, so they can also be worked by water works, but there is one thing certain, that when that steam coil fan is on it is a coal and water consumer, and if I was in a position to, I would make an attachment where the producer gas and gas engine is used to cut the steam out and drive the fan from the gas power and draw in the fresh air past a gas-heated surface after the producer and engine were in use, thus again saving coal and water. This would beat burning gas under the boiler for economy.

The heater is upstairs in the producer room, with the top of the producer and fans for removing the tar, also the clutch pulley for throwing in and out of gear the coal elevator, which hoists the coal from a downstairs coal bin (which is located along side of the coal switch) up to the large coal hopper above. The automatic coal feeds on the producer where it is let down into one of a 350-pound capacity when needed. The 2,000 cubic feet gasometer, including the sulphur purifier, are located outside of the building with all pipes leading to and from them underneath the ground. The purifier has by-pass valves. The water pump, running off the producer shaft, pumps drinking water up to the top of the building into a tank, and from there it runs to drinking

stands throughout the factory hydrants, etc. There is a hydrant by the cupalo to put out the fire when the bottom is dropped every day. This water is also used in the nickel-plating room to keep drop hammers cool, etc.

The next improvement to be made here was to put in larger pumps and pump all of our water for the producer and gas engine, and to run all drain water from the engine cylinders and producer, etc., into a cistern through a filter and pump it out by power pump running off the gas engine and use it over again by using cooling tower and gasometer, or some other arrangement, instead of running it out into the commons and wasting it from the water works at a cost of about \$30 per month.

Two men run the entire power house. The producer tender also fires the boiler and it is most too much, the way things are installed here in the winter time when the heater is on, as the running up and down stairs from the boiler, etc., adds to the unnecessary work. As engineer in charge I see to the entire plant, including 11 motors and lights, also the electric night watchman's clock, etc., as well as the producer room.

It is very important in a producer plant of this size, where only one producer is used, to get a good man, as it is not like where you have a battery of producers and can afford a gas foreman to stand over the men and tell them what to do. In this kind of a plant a producer tender must be capable of being his own foreman and know what to do, and when to do it, to save coal, and one that can be trusted to show up every morning. Because, with one producer, it is more important that the gas be kept constant, or it deranges everything. As the gas furnace demands good gas we always have good gas for the engine. When the engine is pulling 250 amp. and the other line shaft and the gas furnace are all on, including the enameling or core baking oven, it requires about one hopper and a half of soft coal an hour, 525 pounds, depending very much upon the way the producer tender handles it and the grade of coal. The boiler used about 20 per cent of this amount, also depending upon how the boiler is handled. Of course, as explained before, not all the steam is used for the 300 H. P. producer. When the steam heater is on in the winter time,

and 11 other steam connections that are required through the factory, the coal required for the 65 H. P. boiler is very much more than that used for the 300 H. P. producer.

When the engine is running full load for ten hours a day we get about one barrel of tar a week, depending again very much upon how the producer is worked. The gas for the furnace is not purified. As we use about 10,000 cubic feet of gas per hour in the engine, for ten hours it would be 100,000 cubic feet, and for six days would be 600,000 cubic feet of gas purified to one barrel of tar. I have seen two barrels gotten from the same producer in one week under different producer tenders. This tar is sold for \$5 per barrel.

I believe a more economical installation for a factory of this kind would have been to install a soft coal pressure producer, made upon the principle of the "Mason" (Duff and Whitfield's patent) of England, where the gas is circulated through the bed of hot coals several times, until the tar is mostly burned up, or turned into fixed gases and then after purifying it stored into a large enough gasometer to furnish gas for the entire plant, including the operating of the little gas engine used in driving the air fan all night without making any gas. The night watchman could start it up when needed, or run it all night in real cold weather, to have things warm in the morning, also heating it with castings, which, as the cold air is sucked in and passes them, heat is extracted from them which heats

the fresh air and forces it through the factory as hot air in the winter time to heat the premises. By this method, especially in our location where it is warm and cold during the season, the wasteful large steam boiler could be done away with, and by running the air fan without heating up the coils, cool air could be forced through the factory in the warm weather. To reduce the expense of buying a large gas engine and generator, switch board and motors for every department, I would install a 10 H. P., 20 H. P., 35 H. P., etc., gas engine in every department, and then when you wanted to use only a little power, you would not have to run the large gas engine and generator. When you did not need steam for other purposes a soft coal suction producer would be preferred with a fan to suck the air, steam and then gas through the different purifiers and force it into the gasometer at a pressure, therefore doing away with the chance for any leaks of gas at the producer end. The suction effect that the stroke of the engine direct connected to the producer would have upon the producer would have to be regulated by a weight upon the tank. When it would descend the weight would also descend and pull on a rope and open a slide valve in the main gas pipe between the producer and tank. As the suction fan would be run continually by the same engine that runs the hot air fan, etc., it would start to making and filling the tank with gas, therefore giving the same results as the vacuum in the engine cylinders would in regulating the making of the gas.

A FLY WHEEL FORMULA.

R. E. Mathot, the Belgian gas engine expert, gives the following formula for fly-wheel dimensions of different types of large engines, having regard for the use to which the engine is to be put:

$$P = K \frac{N}{D^2 a n^3}$$

P = the weight of the rim, without arms or bosses, in tons.

D = diameter of center of gravity of the rim in meters.

a = the degree of irregularity.

n = r.p.m.

N = number of B. H. P.

K = coefficient varying with the type

The total weight of the fly wheel is $1.4 \times P$.

K is given in the following values:

44,000 for four-cycle engines, single cylinder, single acting.

28,000 for four-cycle engines, two opposite cylinders, single acting, or one cylinder double acting.

25,000 for two cylinders, single acting with cranks set at 90 degrees.

21,000 for two twin cylinders, single acting.

7,000 for four twin opposite cylinders, or for two tandem cylinders, double acting

THE REASONING GAS ENGINE OPERATOR.

BY ALBERT STRITMATTER.

"What's the matter with my engine when starting? I can't tell for certainty when she will start. Sometimes she starts off on the first trial, other times I may be five minutes getting her running."

"Well, let's see how you start it. How do you go about it?" was the reply.

The first speaker was the owner of a stationary engine of medium size, about 15 H. P. He went through the usual proceeding of turning the engine over to the proper position, working the gasoline pump to get up fuel, adjusting the igniter to starting position, getting the priming charge of gasoline and air into the engine and then proceeded in leisurely manner to pull back against the compression and operate the igniter. But, as the expert nearly expected, it failed to start, in fact there was no ignition or explosion.

The expert then explained to him that the whole difficulty was due to his slowness in pulling back against the compression and snapping the igniter at the proper time. By swinging on the flywheel a couple of times to get a little momentum, then bringing the piston back hard with a quick motion, and operating the igniter at the proper time, he got a good explosion the first time and the engine started off at once.

Increasing the compression of an explosive charge in the gas engine cylinder increases the readiness with which it ignites, as some gas engine designers have learned to their sorrow in building high compression engines. If, in starting, the piston is brought back with a leisurely movement there is a chance for the compression to escape to some extent, as the engine is usually cool and the piston and rings have not become expanded by heat so as to make a very close fit and hold the compression. Therefore, if ignition does take place in starting under the condition of low compression, the explosion has less force and may not turn the engine over even.

Operating the igniter at the proper instant also has very much to do with the success of the starting. If the charge is ignited too soon, the engine tends to reverse, if it is ignited too late the force of the explosion is not great enough to keep the engine moving.

With small stationary or marine engines, or with automobile engines, quickness in turning the engine over in starting means very much in the success or failure of the trial.

The fuel is drawn in through the vaporizer or carbureter in better condition, and the starting of the engine on the first turn depends much on the condition in which the fuel reaches the cylinder. For instance, the operator of many marine engines may open the generator valve too wide, so that the engine floods. The engine does not start, and continued turning merely adds to the trouble until the valve is throttled and the mixture is regulated better. The writer recently saw just such a case as this, and it was perhaps half a minute before the engine got started. Later on the engine was stopped, and, on starting, the engine had hardly turned more than a quarter of a turn before it got its first impulse and started off nicely, showing that the success of its starting depended entirely on the way it was handled.

One thing to be borne in mind by the reasoning gas engine operator is the fact that an engine, which has once run for hours or days at a time with excellent results, has nothing radically wrong with it. Providing there has not been sufficient wear to cause bad results, and that there are no breakages, an engine which has once given satisfactory service should do equally as well later on. If it does not start at once it is foolish for the operator to try to make it start by continuing to pull and tug at it, or to keep on turning it over without reasoning and endeavoring to find what is the trouble. Poor adjustments will not be corrected by continuing to pull at the engine. Neither will such treatment renew a weak battery, or fill an empty gasoline tank.

Failures in starting, in addition to being caused by a lack of dexterity in the act of starting, and by an improper ignition timing or fuel mixture, may be due to several other things.

Something caught on the valve seat, or striking of the valves for any cause, as gummed lubricating oil, will prevent the engine from holding its compression, and, therefore, it will not start. Poor compression

sion may, of course, also be due to other things, as a leaky gasket, or a leak past the cylinder.

On inspecting a 22 H. P. engine which was for sale, the writer found that the compression was so poor that the engine could be turned clear over on the compression with very little effort. The owner showed his lack of understanding of gas engine operation when he said: "Oh, that doesn't amount to much, it makes no difference." But when the engineer was asked as to why he could not start the engine in less than 15 minutes, he attempted no explanation. The leak in compression was past the movable electrode of the igniter, which was not tight. Of course, such conditions as these do not come about in a day. They gradually grow worse and worse and worse, and are possibly not noticed until they get in a very

bad condition. Many an operator does not realize how hard he has been working to start his engine until he has it rebored and a new piston fitted. Then, when he starts the engine, he realizes how much more easily it starts with the good compression.

When the first attempt results in failure to ignite, there are many operators who add more trouble by failure to realize that there is a charge of gasoline and air in the cylinder and the addition of another charge simply makes the mixture too rich to ignite, and a second and successive failures are almost sure to result. The best way to do under the circumstances is to open the relief cocks and blow the mixture out of the cylinder by turning the engine over a couple of times. Then, by beginning over again, there is more likelihood of a successful start being made.

PATIENCE WITH THE GASOLINE ENGINE

Before a purchaser, who has never had any experience with the gas engine, can get the best results from it he must become acquainted with it. And quite a bit of patience is necessary. I just had a letter from a man in the State of Alabama, who is certainly an heroic example of patience, but he is surely being rewarded for his patience and efforts. He intimated that he was unfortunate in living in a community where no one knows anything about gasoline engines and that he is not able to learn of any other, besides his own, within a radius of 50 miles from him. He purchased a small gasoline engine sometime in January, did his best for two months thereafter to get it started. He wrote us several letters telling wherein he thought he failed, and after we got him straightened out by correspondence on that point he found that there were other things that he had neglected to inform himself on. It appeared that he studied only one part of the engine at a time, and did not regard it as a whole, and that the various parts must act in harmony in order to operate successfully. He had, however, been running his engine a month or two when he wrote his recent letter, but intimated therein that it wasn't running right yet, that he hadn't been able to get it to exhaust regular. He had a hit-and-miss

governor on his engine and after reading his letter we concluded that he was trying to have his engine exhaust regularly like a steam engine. That he had no doubt been operating his engine quite successfully for some time and did not know it. He felt worried because his engine did not exhaust regularly. The very thing it should not do unless he had it loaded to all it was capable of pulling. The same kind of a mistake is frequently made by persons who have been accustomed to operating steam engines, and the worst of it is that it is often a slow process to get them to understand the principle upon which the hit-and-miss governor acts and why the exhaust is so irregular and why it should not be regular like the exhaust from the steam engine. The principle upon which the hit-and-miss controls the speed of an engine is to control the number of impulses rather than the strength of them. The charges admitted are all supposed to be of full and uniform strength. But under a light load one impulse of charge is of sufficient strength to increase the momentum of the flywheels so that they can carry the load for a number of turns without the help of immediate successive charges, and consequently the governor cuts them out entirely until another is needed. When no charge is admitted

there of course can be no report from the exhaust. We will hear one or two reports and then notice a miss of that many or more. The exhaust reports are, therefore, very irregular. But that by no means indicates that the engine is not running properly. In fact it is generally an indication that it is doing very well, handling its load easily, and using less fuel than if the exhaust reports were regular. This man had operated a steam engine and it was a slow process for him to drop the idea of applying his steam engine practice to the gas engine. Had it not been for the great patience he manifested he certainly would have given up in despair long before he got his engine started at all. But he showed a determination that not one out of one hundred persons would need to possess. Fortunately, almost every one who buys an engine can put it in successful operation with one-tenth part of the persistent effort necessary with this man. In almost every community now some one is near at hand who has had enough experience to assist a beginner over the rough places and show him the real principle upon which the gasoline engine operates. Then again it appears easier for one who has never operated a steam engine to understand the functions of the various parts of the gas engine. A certain amount of patience, as well as effort, is necessary with the gas engine. In contrast to the quiet determination and patience shown by the person above referred to, I will refer to a man who only lives about a mile from the factory where his gas engine was made. The manufacturers set up his engine, started it for him and showed him how to start and stop it, and told him about the various parts and their functions, but he apparently paid no attention to their instructions but the start and stopping part of it. He has, after one year's experience with his engine, utterly failed to grasp anything about the principle upon which his engine operates, and, consequently, his engine receives no care. The working parts were soon badly worn and out of adjustment. Whenever his engine refuses to run he telephones the factory and says his engine will not run, and as a rule the man who is sent to answer his call reports that a nut had worked loose or that some part

was so badly worn for want of care that it could not perform its function, or that he had gotten a wire disconnected from the battery to the engine.

In every instance there is shown such a lack of attention, such gross carelessness, on the part of this man which would indicate that he never would learn any thing about his engine unless some vigorous refusals to attend him further come from the manufacturers. He always expected their services gratis, and indicated by his manner that he put his entire dependence for the continual running of the engine on the persons who built the engine. You can imagine what a howl came from this man when he received the first bill for services. He was advised that further service would cost him for all time and expense put in at his solicitation. You can also imagine how utterly helpless he was. He simply hadn't given his engine any thought, nor did he try to know anything about it. The opportunity he had was such that within a week after receiving his engine he should have been able to care for, operate and adjust it when it needed adjusting, without the help of anyone. I might say here, that if an engine is given the proper care and attention right along, very little adjusting will be necessary. We have endeavored to give in this article the two extremes of patience with the gas engine. The first party wrote only a few letters of inquiry during his long trials of earnest endeavor. These letters were always pleasant and expressed confidence in the engine, as well as in himself, but indicated patience enough to work out carefully, all alone, the full details of its operation, if it took a year to do it.

The other person depended entirely upon some one else, had no confidence in himself or his engine, and was almost hopelessly careless about it, and was absolutely impatient with it, because the instant it refused to start he would call the factory by telephone without making any attempt to locate the cause for its refusing the start. There is nothing so important to the new men with a gas or gasoline engine as patience and determination. Every man who buys a gas or gasoline engine has some confidence in it, otherwise he would not put his money into it. But if he has no confidence in

himself or his ability to properly operate and care for it he had better not purchase one. The man who is full of patience, determination and confidence always succeeds sooner or later with the gasoline engine, the great majority of them within a few weeks. The amount of trouble

an operator has with his gas engine is in almost direct proportion to the amount of patience, effort and attention he bestows on it during the first month he has charge of it. He will have easy sailing if he attends it properly at first

—*Canadian Implement and Vehicle Trade.*

C L I F T O N M A R I N E E N G I N E S

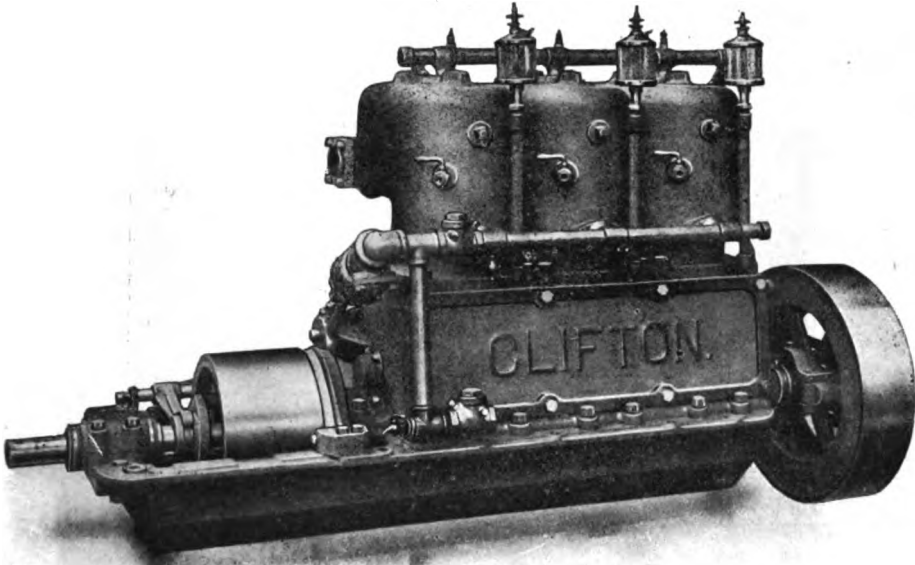

21 H. P. CLIFTON ENGINE

In our last issue we made mention of several gasoline propelled canal boats which are in use on the canal between Cincinnati and Dayton, O. Five of these boats are equipped with "Clifton" motors, built by the Clifton Motor Works, 227 E. Clifton avenue, Cincinnati. Orders for four more have been placed with the same company. In the accompanying illustration is shown the "Monitor," one of the canal boats, and the three-cylinder 21 H. P. Clifton motor in use on same. This motor has a bore of $6\frac{1}{2}$ inches and a stroke of 7 inches, and weighs, complete, about 1,550 pounds. The speed ranges from 100 to 600, the normal speed being 400 r.p.m.

The cylinders are cast without separate heads, the top being closed and water jacketed.

Each piston has four packing rings and is made dome-shape on top to allow of expansion when hot. The connecting rod is a steel forging with upper end bushed with hard bronze. The lower end is a bronze casting, split and bolted onto the connecting rod by two special steel bolts.

The crank shaft is an open hearth steel forging worked out from the solid billet.

Both inlet and exhaust valves are opened mechanically, the latter being set to give maximum power of the engine after careful experiments. The valves are made of drop forgings, of large area, so that the inlet and exhaust passages offer least possible resistance to the flow of the gases. The valve stems are thoroughly water jacketed.

The cam shafts runs in bearings cast

in the main housing and is covered with a casting which contains the cam rollers and guides. Removing this casting exposes the cam shaft to view and also removes all the cam rollers and guides so that ready access is had to shaft and bearings.

These engines are equipped with jump spark type of ignition. The contact maker is on the cam shaft at the forward or flywheel end.

To control the speed of the engine when the clutch is thrown out, a centrifugal governor is contained in the flywheel. This governor operates a throttle

valve on the intake pipe and prevents the engine running above a fixed speed. The clutch is often arranged to be operated from the pilot house, and the pilot need have no fear to the engine running away and wrecking itself

Relief cocks are provided in the one and two-cylinder engines for starting. Relief cams for holding open the exhaust valves are provided for three, four and six cylinder engines.

The engines are built in units from 7 to 45 H. P., of from one to six cylinders. A smaller engine is now under course of construction.



OIL IN THE GAS ENGINE CYLINDER

The following is quoted from a publication sent out by the Joseph Dixon Crucible Company, Jersey City, N. J.:

The chief engineer of the gas engine department of a large manufacturer of gas engines, writes us as follows:

Oil in a gas engine cylinder is the greatest curse that we are pleased to class among necessary evils, and is only tolerated because no substitute for it has, up to the present time, been found.

In the first place, it is very difficult to apply oil to the gas engine cylinders in such a way that it reaches all the surfaces to be lubricated, without considerable waste; in fact, it is an absolute impossibility to lubricate a gas engine cylinder without wasting considerably more than half of the oil.

Lubrication in a gas engine cylinder must be effected entirely by spreading, while in a steam engine cylinder, lubrication is effected, to a great degree, by an atomization of the oil.

Oil which is applied to a gas engine cylinder on the inhalation and compression strokes, is carbonized on the power and exhaust strokes, with the result that counterbores of cylinders, piston faces, cylinder head faces, inlet and exhaust valves, piston and packing rings and piston rods, in fact all parts which come in contact with the oil and heat, are coated with deposits of carbonized oil, which causes such parts as packing ring grooves and ring cuts to fill up with this carbon, giving no end of trouble and necessitating cleaning very much oftener than would be necessary if the use of oil could be dispensed with.

In addition to the above troubles, this oil is thrown back into the counterbore, where it is carbonized, and coked, causing, in varying periods of time, pre-ignitions, due to the accumulation of this incandescent body. If the exhaust valve is placed in the bottom of the cylinder in such position as to allow this oil to pass out, its seat, and the top of

the valve, would become recipients for the carbonized oil with effects very much more disastrous than though the carbon is allowed to rest in the counterbore of the cylinder.

Again, igniter trouble can be traced, in a great measure, to oil accumulating around the insulation, as well as on the igniter,

causing missing of impulse strokes, and becoming deposited on the points to such an extent as to prevent metallic contact.

In addition to the above, the mechanism required for applying the oil to these cylinders is such (the quantity of oil delivered on each stroke being relative small), that possibilities of erratic feeding are very great.

PRONY BRAKE CAPACITY.

The *American Machinist* calls attention to the proportions between a Prony brake and the load the brake is able to absorb. The Union Gas Engine Company, of San Francisco, in testing gas and gasoline engines, uses the type of brake having an iron drum with internal flanges, with water connections for absorbing the heat. The brake blocks are of maple and attached to an iron strap which nearly surrounds the drum.

One of these brakes has a drum of thirty inches diameter and twenty inches face, and at 250 r.p.m it is found to be capable of continuously absorbing 140 H. P. It will also absorb power in excess of this for short intervals, but for continuous work that figure represents the limit of its capacity as, with an increase of 150 H. P. the water will not absorb the heat and the brake takes fire. Taking 140 H. P. as the limit, we may easily determine the brake surface per H. P. thus.

At 250 r.p.m the peripheral speed is

30
 — x 3.1416 x 250 = 1963.5
 12
 feet per minute, and the total surface passing under the brake block is

$$1963.5 \times \frac{30}{12} = 3272$$

which gives
 3272
 — = 23.37 square feet per H. P.

140
 Since this figure represents the limit of the brake's capacity it should, of course, be somewhat increased when used in designing —thirty feet being probably a suitable factor.

It would be interesting, continues the writer, to compare this factor with others obtained from brakes running at different circumferential speeds. It would not appear that there should be any material variation at different speeds

BOOK REVIEWS.

"Gas Engines and Launches," by F. K. Grain, M. E.; 123 pages, 4½x6¾ inches, 21 illustrations. Price, \$1.25.

This is one of the best books which we have seen for the use of the novice in marine engines and launches. The term "gas engines" in the title is the generic term, and the book relates principally to marine engines, although, of course, the description of the operation of two-cycle and four-cycle engines, ignition, etc., apply as well to stationary engines, or to purely gas engines. It is to be regretted that no index or table of contents was included in the book, as the reader who is searching for some particular paragraph or matter relating to some specific sub-

ject, is obliged to hunt until he finds it. While we do not like the spelling "gasolene," still, there is no recognized standard in this matter. Neither can we agree with the author that water jackets are "universally employed on all successful engines, excepting very small engines for bicycle use," or that "vaporizers are now so universally employed that it is hardly worth while to mention any other device . . . all other devices being practically out of date." However, the description of the operation of engines, the methods of lubricating, igniting, etc., are all very clear and should prove interesting and instructive to readers of the book. The last half of the book is devoted to

troubles in general and hints on the care and operation of engines. This portion of the book is particularly instructive to the novice. The illustrations include wiring diagrams and half-tones of numerous types of marine engines on the mar-

ket. An excellent feature of the book is the lack of anything in the nature of catalogue descriptions of various makes of engines, a matter which too many authors are inclined to clip from catalogues and include in their works.

A COMBUSTION SIGHT - HOLE

The "examiner" described in Mr. Haenssger's article in this issue, and illustrated in Fig. 10, is a very interesting device for use in testing engines, and one which might well be used in stationary, as well as automobile engine testing. As shown, it is not adapted to the use of make-and-break igniters, but for such engines we suggest the use of a device designed by Prof. William T. Magruder, and described and illustrated in *THE GAS ENGINE* of March, 1902. The device may be suitably

the inner side of the cylinder head should be several inches. It should also be so small in diameter as not to touch the inside of the reducer. The strength of the plate glass is ample for the pressures which come upon it when mounted in this way. With this piece of apparatus the interior of a gas engine may be viewed while the engine is in operation, and much information of value to the tester and designer may be gained. While it is not probable that the glass will break, yet it is safer not to place

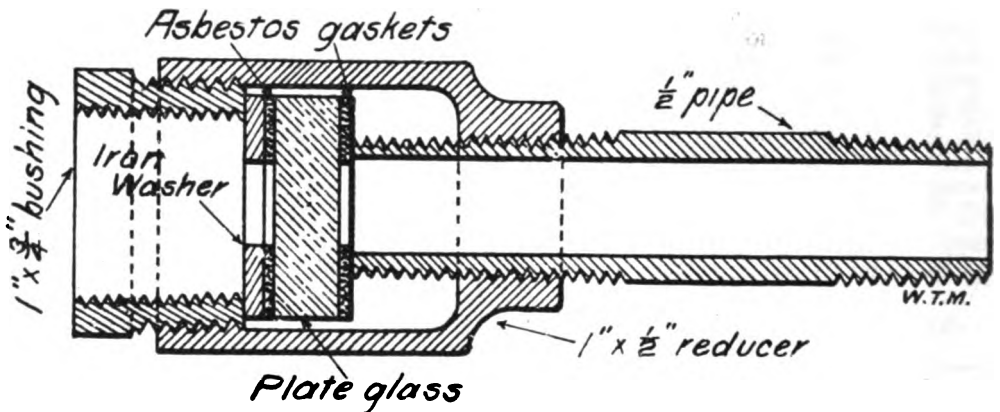

located, according to the design of the engine. We reprint the description and illustration of the device, which Prof. Magruder calls a "Combustion Sight-Hole," for the benefit of our new subscribers of the last three years.

Into the cylinder, preferably the head, is screwed a pipe nipple, say $\frac{1}{2}$ inch iron pipe size, and having a long thread on one end, which is screwed into a $1 \times 1\frac{1}{2}$ inch reducer, in whose outer end is screwed a $1 \times \frac{3}{4}$ inch bushing, used as a stuffing box nut in holding a piece of thick plate glass in position at the end of a $\frac{1}{2}$ inch nipple. The glass is separated from the nipple and the iron stuffing box washer by means of asbestos gaskets. To keep the glass from becoming overheated, and breaking, its distance from

one's eyes too close to the glass, but to stand at a distance of a few feet. The cost of making this device is under a dollar, and it is well worth the money to one whose business it is to test gas engines. By its use the tester can tell when he gets a yellow flame showing a poor mixture, and when he gets the bluer flame

Watch the progress of the gasoline motor car on railroads. Reliable mechanical engineers are predicting a certain sphere of usefulness for them. It seems reasonable to suppose that if a gasoline locomotive (alias an automobile) will run on country roads, it will run on smooth, stiff steel rails.—Columbus (O.) *Dispatch*.

MECHANICAL EFFICIENCIES OF INTERNAL-COMBUSTION MOTORS.

Several months ago we reviewed in these columns the discussion which took place in the Society of German Engineers upon the question of the proper method determining the mechanical efficiency of an internal-combustion motor, and since that time there have been some additional contributions to the discussion, which is by no means closed.

It may be recalled that the matter under discussion involves a fundamental definition, which, while it has never arisen in the case of the steam engine, and is of negligible importance in the case of small gas engines, becomes more important when the larger sizes of gas engines are considered. Ordinarily the mechanical efficiency of an engine is supposed to be the ratio of the indicated power of the B. H. P., and it is intended to show the excellence of the mechanical performance of the machine as distinguished from its thermal performance. In the case of the steam engine the indicator diagram is supposed to show the total power developed in the cylinder; that is, the heat energy converted into mechanical energy, while the losses due to friction, etc., occur between the cylinder and the delivery belt.

In the case of the gas engine, however, the conditions are not altogether the same, and the result is that there is room for difference of opinion. In the ordinary four-cycle engine, the compression stroke takes place in the same cylinder as the power stroke, and its resistance appears on the indicator diagram. In the case of a two-cycle engine, however, the resistance of the compression pump is not apparent on the indicator diagram. In the case of a two-cycle engine, however, the resistance of the compression pump is not apparent on the main indicator diagram, and if it is allowed to go in with the other internal resistances of the engine the mechanical efficiency will be correspondingly lowered.

From the standpoint of the user of the engine no method can be satisfactory which does not include the real amount of power available for driving his useful machinery, and he is not interested in the power re-

quired to drive the pump, since it is not at his disposal for manufacturing purposes. It is, therefore, always desirable that the B. H. P. of an engine be stated. The designer, however, is interested in knowing how the internal resistance of an engine are distributed, and it is certainly desirable that uniformity of practice in this respect be observed, especially in connection with reports of tests and trials.

In a recent issue of the *Zeitschrift des Vereines Deutscher Ingenieure* there is given a further addition to the discussion of the question by Mr. Rudolph Diesel, who is well qualified by experience in the design and construction of internal-combustion motors to speak upon the subject. Mr. Diesel takes up the matter in the true scientific problem, not as a question for dispute, but rather a laboratory problem, to get at the truth. He believes that the question is largely one of definition, and that the uncertainty existing at present would be removed by the adoption, by some authoritative body, such as the Society of German Engineers, of determinate meanings for the various expressions employed. His nomenclature is as follows:

Indicated power; means the full power indicated in the working cylinder without any deduction.

Useful power; the bare amount of power wholly available for external work.

Effective power; the useful power, as defined above, plus the work required to operate the compression pumps.

Mechanical efficiency; the useful power divided by the indicated power, according to the above definitions.

Dynamic efficiency; the effective power divided by the indicated power.

Pump ratio; the result obtained by dividing the work required for the pump by the indicated power.

Friction ratio; the difference between unity and the dynamic efficiency.

It may seem rather elaborate to insist upon so many classifications, but these various elements are all there, and they all have to be taken into account, either in public tests or in private study and research, and hence it is most important that they should have

recorded names and definitions, concerning which there can be no dispute, and to which authoritative reference may be made. In the course of the development of the Diesel motor a remarkably high thermal efficiency was attained at the start, while a considerable proportion of the power derived from the fuel was absorbed in the various mechanical resistances of the machine, partly owing, no doubt, to the high working pressures involved. As experience was gained in the construction and operation of the machine these internal resistances were materially diminished, and in the motors of more recent construction a much greater portion of the power developed in the cylinder is available for external work, so that Mr. Diesel knows very well the nature and magnitude of the internal resistance which the engineer encounters in such work.

Like many other disputes and discussions, differences of opinion arise when men are not talking about the same thing, and as soon as clear and comprehensive definitions of the terms included in the argument are adopted the differences naturally disappear. The engineering profession will do well to examine these definitions suggested by Mr. Diesel.

It is a matter of interest to note that while this discussion has not actively arisen in connection with steam engine trials, the elements for the same differences exist as in the case of internal-combustion motors. Thus, in the case of the ordinary condensing engine, as it has been built since the days of Watt, the air pump has been driven by the engine itself, thus forming a resistance not materially different in nature from the compressing pump of the gas engine. In recent years, however, especially for large marine engines, it has not been unusual to find the air and circulating pumps operated independently, and this practice is also entering into stationary power-plant designs. Unless the engine in the latter case is charged with the power required for these independent pumps, its mechanical efficiency, according to the usual definition, is not computed on the same basis as in the case of the engine in which the air pump is directly connected to the crank or cross-head. By using the broad definitions suggested by Mr. Diesel, however, any uncertainty as to the meaning of the expressions will be removed, regardless of the kind of engine to which they may be applied.—*The Engineering Magazine.*

PRODUCER GAS VS. GASOLINE IN MINE HOISTS.

At a recent meeting of the Institution of Mining and Metallurgy, W. H. Randall read a paper on "Producer Gas vs. Gasoline in Mine Hoists," from which we have made the following abstracts:

"At the Guadalupana mine, near Moctezuma, San Luis Potosi, Mexico, a 25 H. P. gasoline engine was installed to do the pumping and hoisting in a small vertical shaft, 200 feet deep. The pump was an ordinary bucket pump, worked by rods from belt-driven gearing at surface, and raising the water in one lift. The plant proved very expensive in operation, the consumption of gasoline (at \$8 per case of 10 gallons delivered) amounting to \$20 for two shifts of 8 hours, 16 hours' work.

"A small suction gas producer plant was then installed at a cost of \$1,000, and has been running for a couple of weeks unwatering the mine. A calculation, based on the actual quantity of water raised during

a period of 24 hours, gives an average (including all stoppages and making allowance for friction of working parts, etc.) of 3.20 H. P. per hour for the whole period, with a consumption of charcoal in the producer of 140 kg., i. e., 1.82 kg. of charcoal per H. P. hour. The charcoal delivered at the mine (and allowing for loss due to pulverization in transit) costs 2½c per kg. The cost per H. P. per hour is therefore 4.55c. I am unable to make an exact estimate of the economy over gasoline, as no attempt was made to gauge the actual work.

"The cost of power per 24-hour day with the gas producer averages: Charcoal, \$3.75; petroleum (extra lubrication of cylinder, inlet and check valves, not required with gasoline), \$1.50; labor (boy stoking and looking after gas producer), \$1.50; total, \$6.75. This compares with an average of \$30 per 24-hour day when running with gasoline, or an economy of over \$20 per day.

"Of course, the fuel consumption of 1.82 kg. of charcoal per H. P. hour is much higher than the 2.6 lbs. wood and 0.11 lb. coke at Nacozari; but, considering the small size of the plant, its great simplicity and small first cost, it compares favorably with steam under similar conditions. It must be remembered that the actual water delivered has been used as the basis of calculation; the fuel consumption per B. H. P. probably does not amount to more than two-thirds of the figure given.

"The only alteration that was made to the engine on changing from gasoline to producer gas was the insertion of a liner between the crank and the crank head, thus causing the piston to travel farther back into the cylinder, and thus proportionally increasing the compression of the gases be-

fore ignition. The loss of engine power, when running with producer gas instead of gasoline, is considerable; and with the engine in question is not less than 30 per cent, the actual power obtainable being barely equal to half the makers' rating.

"I quite agree with the general opinion as to the reliability of the steam engine, especially where a skilled machinist is not available. Where fuel and water are scarce, however, and transport difficult, as in many parts of Mexico and South America, the gas engine and gas producer for mining purposes have, I believe, a great future before them, especially when one takes into consideration the smaller weight and much greater portability of the different parts of a gas producer, as compared with a steam boiler of similar capacity."

A COOLING WATER ARRANGEMENT FOR GAS ENGINES

Gasoline engines have become an everyday matter; indeed, they and their next of kin, the producer-gas engine, bid fair soon to be "the whole thing" in the way of power generation.

It is reprehensibly common, when one sees one of these engines installed where the climate is cold, to find the water-jacket of the cylinder cracked, from having been allowed to stand full of water during freezing weather. Although this accident does not necessarily seriously impair the usefulness of the engine and, in mild cases, is easily repaired, it is a disagreeable and unsightly thing, whether repaired or not, and a word as to how to avoid it may not come amiss.

It is true that this freezing of the cooling water may be avoided by putting some glycerine in it (quite a large percentage, by the way), or by using oil to cool with; but, aside from the expense of either of these methods, pure water is decidedly the best cooling agent known, and the simple arrangement which I will undertake to make plain eliminates all bother and expense and saves some room.

First, make an underground cistern—a common wooden tank is all right and will last for many years—of sufficient capacity so that, supplied from the roof, it will hold enough to last all winter; thus securing a permanent supply of soft water and avoiding all trouble from lime incrustation in the cylinder. This will not require a prohibitively large tank, as there will be no loss, except by evaporation, and twenty-five or thirty barrels will ordinarily last a 10 H. P. engine for six months or more.

The tank is preferably placed so that the pump may be directly over it and arranged substantially as in the diagram, though, of course, each location will call for minor modifications in the arrangement. A common deep-well pump cylinder *C* is placed at the bottom of the tank *A*, and a pipe is carried up into the bottom of reservoir *B*, placed about 2 feet above the level of the top of the engine cylinder. This reservoir may be any kind of vessel which will hold

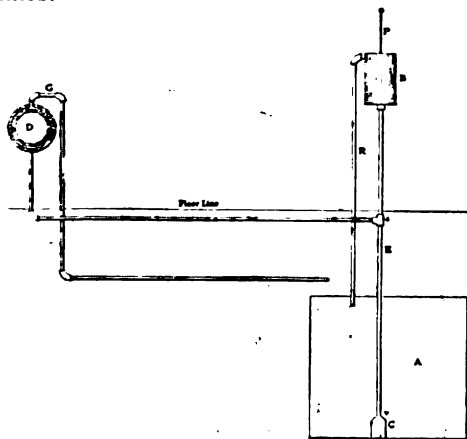

3 gallons or more. The pump rod P extends up through the pipe E and the reservoir B , and is attached to any convenient mechanism for giving it the desired reciprocating motion. At some point e in the pipe E , preferably below the floor, a "T" is inserted, from which branches the pipe a , entering the bottom of the cylinder water-jacket. The overflow taken from the top of the cylinder is carried back to the tank in any convenient manner, as by the pipe r . A hole, about 1-16 inch in diameter, is drilled at the point v in the pipe E , and left open at all time, so that, immediately the pump stops, the water drains back.

As it is difficult to gage the capacity of the pump so as to give the best results, and as such capacity will vary somewhat in any case, it is well to have it of ample capacity and to have a stop-cock at G , by which the flow can be gaged to suit, while the surplus is returned to the tank by the overflow pipe R , which is attached to the reservoir B , near

its top. It might be well to remark here that about the highest degree of heat permissible in running gas or gasoline engines is generally conceded to be indicated by a cooling water temperature of about 150 degrees as it leaves the cylinder, which is about as high as the hand will bear without being scalded. The reservoir B is not absolutely essential; but without it one would have to carry the pipe E some distance above the overflow R , in order to avoid disagreeable splashing, and the pressure, and consequently the flow, would be somewhat irregular.

I have operated an engine, piped in this manner, for five years, in a climate which is "the limit" for low temperatures, without the slightest attention or expense, except to see that the pump was running. If memory serves, the entire amount of care involved has been the lacing of one 2-inch belt one time; and oiling, of course.—W. D. GRAVES, in *American Machinist*.

IMPLEMENT DEALERS AND THE GASOLINE ENGINE

In its attitude toward the gasoline engine the retail implement trade seems to have been divided into three classes. In the first and best class are the dealers who either recognized the value of the gasoline engine as a farm motor or accepted in good faith the representations made to them along that line, and engaged in the sale of it vigorously and with enthusiasm. In the second class are the dealers who, while admitting that the gasoline engine can be used to advantage by the average farmer, contend that the average farmer will not be deeply interested until the motor can be purchased at a lower price. The dealers of this class are not entirely neglectful of their opportunities. They are on the alert for orders, but are unwilling to invest, as dealers of the first class have done, in a sample engine. The third class consists of dealers who have thus far evinced no interest in the gasoline engine and who have done nothing to promote its sale.

It is a matter of common knowledge that the dealers who have taken up the sale of these engines in an approved manner, carrying a sample and acquiring the ability to demonstrate their value to the farmer, have increased their volume of sales and

profits materially. Some of them have been so successful that the sale of gasoline engines is now one of the chief profit-producing branches of their business. Inspired by a knowledge of this success dealers of class two are becoming dealers of class one, and occasionally a dealer of the third class awakens with a start and ignoring the middle ground jumps at once into the first section. The sudden realization that the farmers of his community are buying gasoline engines direct from manufacturers is usually the cause.

But how many there are that refuse to improve their opportunities even when brought so forcibly to mind. How many will wait until hundreds of sales have been made and then, having tardily realized that the gasoline engine is a staple farm implement, try to get in line. A great many engines are being sold direct, but not many in the sections where dealers of class one are doing business. Class two dealers lose sales because many prospective buyers go where they can see a practical demonstration. They "talk engine" to the dealer without a sample and kindle hopes of a sale, but their orders are placed with a distant dealer, or a manufacturer whose engine has

been seen in the hands of a neighbor, at an exhibition or at his factory. Then the dealer complains bitterly of direct sales of an article that he is handling. The trouble is that he isn't handling it in the proper man-

ner. When all of the regular dealers become class one dealers in gasoline engines direct sales of gasoline engines will be less frequent than direct sales of other farm utensils.—*Farm Implement News.*

I G N I T I O N T R O U B L E S

This is just a simple talk on ignition troubles and how to avoid them. It is designed, not for the expert, but for the ordinary man. The expert knows what's what; besides that he has a lingo of his own. So I don't intend this for the elect, but merely for the ordinary boat user.

Ignition has been variously estimated to be the source of from 50 to 80 per cent of gas engine troubles. Certain it is that the percentage is large. While some of these troubles are bound to occur, no matter how much care is taken, it is safe to say the majority are directly due to the carelessness or ignorance of the operator.

The contact, or "make and break" system, is almost universally used in marine motors, and will be treated in this paper. Jump spark ignition may have a word in another issue.

First in importance is the manner in which wires, coil, battery and switch are installed. The average motor boat man has an idea that, as long as the end of the wires are in the proper places, it makes no difference how they get there. "It is only battery current." True, battery current will not set your boat afire, but it will leak, and even though the leak be small it shortens the life of your battery.

To obtain good service, good wiring is more important on battery current than on electric lighting circuits. It must be remembered the voltage or "pressure" of your battery current is very low, and that a poor splice or connection adds resistance to the line and greatly retards the flow of current. One corroded connection is often sufficient to cause you to be towed home if you fail to find and clean it. If your wiring is properly installed at the beginning of the season you will have no trouble aside from your firing pins and the occasional renewal of battery. The following suggestions, if followed, will save you trouble, and your battery wear: Use stranded or flexible rubber-covered wire. No. 16-lamp cord is

as good as you can use, and it is not expensive. Solid wire should never be used, as the vibration frequently causes it to break; and when it breaks inside of the insulation it is very difficult to locate the trouble; for it can not be seen and it often causes the circuit to be open only at intervals, as the vibration will bring the two broken ends together at times. When such is the case a test will show no trouble, and you can not understand why you miss explosions or why your engine stops. You will never have this trouble if you use stranded wire.

Locate battery and spark coil where they will be as dry as possible, and secure them so that they will not move about from the motion of the boat. Run wire from battery to coil and from coil to spark plug. Run wire from opposite side of battery to switch and from switch to ground connection on engine. When so connected there is no connection from battery to ground when switch is open, and it will save a leak on battery when insulation on wire is poor. Run wires "high and dry." Never allow a wire to lay in bilge water. Fasten wires with wood or fiber cleats. Staples or double pointed tacks almost invariably cut the insulation and cause grounds.

If splices are necessary make them carefully, and solder. Solder insures a perfect joint electrically and prevents corrosion. Tape the joint well. Use wire terminals on ends of all wires. These should be soldered on. They insure a much better contact than putting the end of a wire under a binding screw and prevent the end breaking.

Leave wire ends long enough to reach six inches beyond binding screw. Coil extra length on percol. This will prevent strain on wire and binding screw. Particular attention should be given to the switch. Knife or open switches should not be used. On account of being exposed to the atmosphere they corrode very badly, as do also the wire connections on them. An enclosed or cov-

ered switch should be used. The ordinary snap switch used for electric lights answers the purpose very well. They may be had with an indicator to show where "on" and "off," and also to be operated by a key which prevents strangers from starting your engine. These switches are not air tight, but sufficiently so to prevent nearly all corrosion. If magneto is used an electronic snap switch will turn on either battery or magneto.

Run all your wires neatly. Neat work is generally good work. Good work is always neat work. Wires hanging loosely around your boat will sooner or later get into trouble. Any trouble is easily located when your wiring is in good condition. If terminals or connections become corroded clean with fine sand paper.

With a good spark coil and battery properly installed you will have but one serious trouble to contend with. That trouble is with firing pins. Firing pins will stick, and contact points will burn. To properly lubricate the firing pin seems to be the greatest trouble. On account of poor lubrication the wear is rapid and they soon begin to leak. Kerosene seems to be the best lubricant for firing pins. It enters the sleeve where a heavier oil would not. Keep contact point of plug clean by removing and rubbing with sandpaper.

All motor boat men can not be electricians, but they can keep their electrical equipment neat and clean, and in so doing they will avoid many troubles and add greatly to the pleasure to be derived from their boat.—*The Motor Boat.*

GAS AS A MOTIVE POWER AND ITS RELATIVE COST.

A recent issue of *Machinery* gives extracts from a paper read before the Canadian Society of Mechanical Engineers as to the relative cost of gas as a motive power. The following are the figures:

Gasoline—The consumption of gasoline in a gasoline engine is one-eighth gallon per B. H. P. hour. This at 20 cents per gallon figures out as follows:

$$0.125 \times 10 \text{ (hours per day)} \times 312 \text{ (days per year)} = 390 \text{ gallons at 20 cents} = \$78.00 \text{ per B. H. P. per annum.}$$

Illuminating gas with the modern gas engine.—One B. H. P. can be produced with from 14 to 16 cubic feet of illuminating gas, or, an average of 15 feet per hour. This figures out as follows:

$$15 \times 10 = 150 \times 312 = 46,800 \text{ cubic feet at } \$1 = \$46.80 \text{ per annum per B. H. P.}$$

Steam.—Since the average automatic high pressure engine of small powers requires from four to eight pounds of coal per hour per B. H. P., take the average six pounds; this figures out as follows:

$$6 \times 10 \times 312 = 18,720 \text{ pounds at } \$4.00 \text{ per ton} = \$37.44 \text{ per B. H. P. per annum.}$$

Semi-water gas from anthracite coal.—The most reputable gas engine builders will guarantee their engines to develop a B. H. P. on one pound of coal in the generator; this figures out as follows:

$$1 \times 10 \times 312 = 3,120 \text{ pounds of coal, } \$5$$

per ton—\$7.80 per B. H. P. per annum.

Semi-water gas from gas coke—The author has recently obtained a copy of a test of an electric power plant of about 80 H. P. The fuel was common gas coke and the consumption was 0.92 pounds per hour per B. H. P.; this figures out as follows:

$$0.92 \times 10 \times 312 = 2870 \text{ pounds of coke at } \$4 = \$5.74 \text{ per B. H. P. per annum.}$$

Water gas.—With large gas plants of 500 H. P. and over, the Crossley Bros. can produce a B. H. P. on 0.80 pounds of bituminous coal per B. H. P.; this figures out as follows:

$$0.80 \times 10 \times 312 = 2,780 \text{ pounds of bituminous coal at } \$4 = \$5 \text{ per B. H. P. per annum.}$$

Power from gasoline.....	\$78.00
Power from illuminating gas.....	46.80
Power from steam engine.....	37.44
Power from semi-water gas (anthracite coal)	7.80
Power from semi-water gas (common gas coke).....	5.74
Power from water and producer gas (bituminous coal)	5.00

While these figures are all right as far as they go, it seems to us that unless attention is called to several features they tend to convey a wrong impression. Referring to gasoline, the cost is based on paying 20 cents a gallon, a price which is

above the average, we believe. If gasoline cost 15 cents, the figures would change to \$58.50. As for illuminating gas, while \$1 is charged in many cities, the price runs as low as 50 cents per thousand cubic feet, in which event the fuel cost is reduced to \$23.40. However, the consumption of 14 cubic feet of illuminating

gas is a little low for the so-called "city gas."

Of course, the cost in the figures given is for fuel alone, and does not take into account water or attendance, which items often throw the balance in favor of the gas or gasoline engine, as against the steam engine.

SOME RECENT ENGLISH INVENTIONS

An invention of T. W. F. Cherry, Newcastle-on-Tyne, has for its chief object to provide an improved reversible, double-acting, gas engine on the four-cycle type and intended for marine use. The improvements relate to engines employing compressed air starters. The compressed air is admitted alternately to both cylinders, which are used for starting and which thus act during starting in a similar manner to a double-acting steam engine, while, when the engine is started, the cylinders return to the four-cycle system.

An English patent granted to G. Marconnet, of Paris, covers a gas producer from pulverulent fuel. The inventor claims that in gas producers ordinarily employed it is difficult to burn fuel containing either a sufficiently large quantity of volatile matters, or fuel whose combustion produces an undue quantity of adhesive clinkers. This difficulty arises from the fact that the fuel to be burned is delivered into the producer in heaps at regular intervals, often wide apart. The parts of which the charge of fuel is composed are first of all conductively heated; and, at the same time, distillation commences in the freshest layers, and simultaneous combustion in the hottest parts. The presence of these layers in contact at a high temperature causes the vitrified portions to become (so to speak) welded together or to adhere to the neighboring walls of the producer; and they ultimately—unless removed—choke up the apparatus. Moreover, as the combustion takes place in a somewhat restricted area, and at a constantly decreasing temperature, the result is that the hydrocarbons are not decomposed.

Again, he says, it is not possible by the ordinary method of combustion to deal with entirely pulverulent fuel, which may consist of continually stirring the fuel heaps to prevent caking, or to fill up the pockets which

form. Another difficulty that obtains in motive power installations having gas engines and gas generators consists in the fact that the engine very often has to produce a variable power and the producer often contains a considerable quantity of coal. The result therefore is that the engine of variable power will be supplied with gas resulting from the more or less vigorous combustion of a constant quantity of fuel, without regard to the power developed by the engine. In order, however, that the composition of the gas producer may be constant, it is necessary that the gas generator should be capable in a given time of burning a quantity of fuel exactly in relation to the power of the engine at a given moment, and to burn it under the same conditions of chemical reaction, whatever this power may be.

The present invention consequently relates to a process and an apparatus which allow of this combustion being made complete and possible whatever the fuel may contain, in volatile products, cinders, adhesive clinkers, and, above all, when the fuel is in the form of very fine dust, and to proceed in such a manner that at any given instant only the exact quantity of coal sufficient for producing the gas necessary for the power of the motor at the instant shall be burnt; the residues of the combustion (cinders and clinkers) being automatically deposited at a part whence they can be easily removed.

First and foremost, the fuel, if it is not already in the pulverulent state, is reduced by grinding to as fine a powder as may be desired. In this form it is deposited in a hopper in sufficient quantity for any desired length of time. The bottom of the hopper is provided with a distributing device which allows the powdered fuel to flow in the form of spray into a vertical conduit. The feed is so regulated that the quantity of powdered fuel falling is greater than is necessary for

the producer to supply sufficient gas to the engine at its maximum power. As the fuel falls into the vertical conduit, the resistance which the air admitted by a branch conduit opposes to its fall has the effect of so dividing it that at a point in the conduit it appears as a cloud of falling coal dust. From this point a feed conduit branches off and at its other end opens into a vertically arranged fall tube. This tube is constructed of fire-clay, and is preferably an elongated rectangular oblong. The two side walls form, in conjunction with the outer walls, jackets or conduits, likewise constructed of refractory earth. The inner walls are each pierced with small holes placing these jackets or conduits in communication with the conduit or fall tube. The gas issues by small holes over the whole height of the wall; and, if a light be put to one of the orifices, the whole column of orifices takes fire.

The base of the fall tube opens into a somewhat larger lower chamber (constructed of refractory earth), which is itself connected by a conduit to a gas purifier, and to the engine or other apparatus in which it is to be used.

Supposing an engine to be used, the operation is as follows: The engine being at rest there falls, by the action of the distribution mechanism of the feed hopper, a cloud of coal dust past the orifice of the conduit. Under these conditions, if one or two turns be given to the engine it will draw in at the branch conduit a fixed quantity of

air, drawing it with a quantity of coal dust in proportion to the speed with which the air passes through the orifice. This mixture of air and coal dust as it falls in the fall tube comes in contact with the burners therein in succession. The coal first begins to distil and then burns as fast as it falls; but, at the same time, a certain quantity of air will be caused to pass through the orifices pierced over the whole height of the opposite inner wall, and this air will contribute to complete combustion. It follows, therefore, that on its arrival at the bottom of the fall tube all the fuel admitted to the tube has been burnt. In consequence of the air and gas which pass through the walls and steam from the orifices, the coal dust, gases, products of the distillation and combustion of the latter, as also the cinders which result therefrom, can not touch these walls.

In a producer gas patent granted to H. C. Smith, Hornsey Park Road, North, use is made of the exhaust from the engine to inject saturated air into the chamber beneath the grate bars. In suction producers he dispenses with the injector and allows the exhaust, with the damp atmosphere, to be drawn in by the engine piston. By varying the amount of exhaust, the temperature in the required generator is maintained. The object is to make the generator partly regenerative, as the carbon dioxide of the exhaust takes up an extra atom of carbon in passing through the incandescent fuel, forming carbon monoxide.

G O R D O N B A T T E R Y I M P R O V E M E N T S

The latest improvement in Gordon batteries provides for furnishing copper element already packed and filled in the perforated cylinder, so there is no trouble to fill the cylinder, and there is also furnished a new cylinder containing copper element with every recharge—so no cleaning of cylinders or copper supporting frames is necessary.

This improvement will be appreciated by users of primary batteries, the necessity of handling any of the parts that were immersed in the solution is entirely obviated when renewing. It is only necessary to unscrew the brass connector on top, drop out and discard the old cylinder and zinc, and empty out the old solution. New zincs and cylinders containing copper element are then

affixed to the cover, as in setting up new cells.

The high standard of efficiency of the Gordon cell is still maintained, and, in fact, increased. Exceeding long life, combined with steady and constant current and capacity of heavy discharge, in addition to the simplicity and ease of handling now obtained, makes the Gordon cell, according to its makers, the most perfect primary battery.

The improved battery and recharge has been supplied on certain orders during the past six months, and has had a thorough "trying out" during that time, and will now be supplied on all orders. The Gordon Battery Company, 439 E. 144th street, New York City, are the manufacturers.



Another trans-continental motor cycle trip is in progress. The best previous record was seven weeks, made two years ago.

A Missouri inventor is said to be working on the following scheme for air cooling: A blower furnishes a current of air which is forced in at the top of a cylinder and the hot air escapes through port holes bored in a copper jacket which fits the cylinder for two-thirds its length.

Just as this issue is going to press the elimination trials of the American entries for the Vanderbilt race were to take place. Twelve American cars are entered. One of the entries is an air cooled car, reported as having an engine of 7-inch bore and 5½-inch stroke.

It is reported that the Chicago & Alton Railroad Company is about to place a gasoline motor car in service in inter-urban transportation of passengers. The Colorado & Southern is also preparing to use gasoline cars in similar service between Cheyenne and Fort Russell.

As one of our contemporaries says, "A great deal has been said as to the desirability of adopting standard sizes, standard threads, etc., in automobile construction, but very little has been done toward effecting reforms in this direction." The great trouble with securing uniformity is that so many manufacturers are in favor of uniformity provided that their present practice be adopted as standard, but many of them are unwilling to accept as standards dimensions which require much changing in their own particular cases. As a rule, all

are united on the benefits to be derived from standardization, but are not unanimous as to what should be the standard. Standardization of spark plug sizes, and some other such dimensions may be accomplished by united action without much difficulty, but when it comes to a uniform set of dimensions for exhaust and inlet passages, "fly-wheel diameters, pistons, connecting rods, etc.," we can see that there is little probability of any considerable adoption of proposed standards relating to such parts. However, much good might be accomplished by the adoption of standard dimensions for the simpler parts, as spark plugs, and it is to be hoped that this may eventually take place.

Fuel consumption tests are one of the best competitive events which have been devised for automobiles, outside of the regular reliability tests. In the recent Pyrenees tour was included a test of this kind covering a distance of 73.44 miles. Forty cars were included in the test. The average horsepower of the cars was 22.1, ranging from 8 to 60 H. P. The average weight was about 3,750 pounds. The consumption of fuel was from .15 to .53 pints per ton-mile, the average being .34.

A year ago one of the prominent automobile manufacturers expressed his opinion to a representative of THE GAS ENGINE that the automobile industry would remain more or less dwarfed until commercial vehicles could be developed and the public educated to their use. More commercial self-propelled vehicles have been built this year than ever before, and the public is getting to realize more and more the advantages of this type of commercial vehicle. From present appearances the coming year is going to show even a greater increase.

SOME EUROPEAN TENDENCIES.

BY OSWALD H. HAENSSGEN.

(Continued From p. 294, September issue.)

One of the most important accessories to a complete jump spark igniter is the spark coil. Owing to the considerable length of high-grade insulated wire that enters into its construction this apparatus is generally pretty high priced. But as its action depends entirely upon the quality, as well as the quantity, of the wire, the price can not be reduced without diminishing the capacity.

Two types of coils are in use. The plain kind consisting only of a primary and a secondary winding, is the only one fit for co-operation with magnetos or other generators of alternating current. The other, a more complicated kind, possesses a trembler or vibrator, and is generally used in connection with sources of continuous current, as batteries, for instance, though the plain coil, will also work successfully. The trembler, however, gives better results, producing not only one single spark, but a series of sparks, as long as the circuit is closed. In high speed engines it has been observed, though, that the trembler would not respond promptly enough to the passage of the current, whereby the moment of ignition was made uncertain. Consequently it has been the aim of the designers to render the action of the trembler more rapid, and especially to do away with the injurious elastic oscillations of the movable piece which occur between the regular electric impulses and which disturb and impede them considerably.

The perfect trembler should be extremely sensitive, it should not stick, should begin to move at once when the circuit is closed and should continue to work, even when the tension of the current has dropped below the regular voltage. Furthermore, the tongue of the trembler should make exact and clean oscillations between the two limits of its stroke, making and breaking the contact at each stroke.

The trembler "Nieuport" unites in its construction all the above properties. The result is gained by very simple mechanical means. It contains the usual part: A tongue-plate of soft iron, about 1-32 inch thick and somewhat wider than the diame-

ter of the core, terminates in a flat steel spring which is fastened by two little cap screws to a metal block forming one terminal of the primary coil. Near the other extremity of the tongue, practically above the center of the cove, a platinum tip is fastened. An adjusting screw carries the opposite contact tip. It is supported by a soft iron bracket, which forms the other terminal of the primary. Besides these customary parts another flat spring has been added. One end of it is slidingly joined to a certain point of the tongue by two little clamps. The middle part of the spring rests upon the heads of the cap-screw and its other end is bored for the passage of a stud, upon which the tension of the spring may be adjusted by two nuts. With reference to the elastic vibrations of the trembler parts it is well to remember that, if an elastic body is caused to vibrate, each particle of it behaves differently. There are neutral points or lines in which the particles remain at rest, while in other places the oscillatory motion about the original axis of the body attains a maximum. The laws that govern these infinitely small deformations have been applied to the Nieuport trembler. In one neutral point of the tongue the contact tip is placed; the other similar point is naturally near the fastening screws. Midway between these two points is a spot of maximum oscillation, and just here are placed the clamps that receive the auxiliary spring. By the opposition of the two springs the elastic vibrations are neutralized so completely that the tongue makes about 3,000 movements per second, and thus opens and closes the circuit just as often. Naturally, the stroke is extremely small, about the seventy-five-thousandth part of one inch, while in common tremblers it is not less than one five-hundredth part of an inch, and often considerably more.

The "Nieuport" trembler is claimed to work equally well on a tension from 2 to 12 volts. The spark has, owing to the immense number of interruptions, excellent igniting qualities; it is like a thick stream of fire of the characteristic violet color. The sticking of the tongue, caused by imperfect contacts offering too little area to the passage of the current, and which may be con-

sidered really a welding process, is entirely excluded. The contact tips must always seat squarely, and thus give sufficient area to prevent heating. The novel trembler may be adapted to all makes of coils easily.

The spark coils called "L'Indicatrice," have a safety spark gap which indicates at once when something is wrong with the electrical part of the motor. The spark gap is formed by a pointed strip of sheet brass extending from one binding post of the primary to a predetermined point near the termini of the secondary wire. If for some reason a spark plug does not work, a spark will appear at the safety gap of the coil, and, in multi-cylinder engines, show at once which igniter requires attention. Thus the arrangement saves much time in case of an accident. Another desirable feature of these devices is the following: The multi-cylinder coils are composed of units that are entirely alike. They may be exchanged without the use of tools by simply withdrawing the defective coil from the box and inserting a fresh one. Each coil is held in place within the wooden casing by a pivoted brass rail, that forms also the electrical connection between the binding post of the primary current and the termini of the coils.

These indicating coils are furnished either with or without a trembler; some types are provided with a voltmeter that shows the available tension upon pressing a push button.

Of the various devices by which the formation of the spark within the cylinder is obtained, two kinds must be distinguished. But both kinds have the common property of being composed of two electrodes, the one of which is insulated from the body of the engine, while the other one is in metallic connection therewith. The principal difference of these main types lies in the arrangement of the electrodes. These are fixed a certain distance apart in the contrivance which is known by the name of jump spark plug. A device in which one electrode is fixed, while the other is movable, is used in make-and-break ignition.

Jump spark plugs have been completely standardized; plugs of any make are interchangeable, as they all are provided with the so-called De Dion thread of .7087 inch exterior diameter. A special thread is required for only a very few motors, and it is to be hoped that this difference will soon disappear. Of all the various motor acces-

sories, very few have been studied with more success. The object aimed at in the multitude of novelties is to render the plug more reliable and durable. Improvements in design and material have been made in order to avoid the greatest difficulty, the short circuit of the high tension current. Short circuit is either caused by a mechanical defect in the insulation, as a crack or pores, or by a conductive coating of soot or moisture upon the insulator. The insulating materials mostly used at present are porcelain, soapstone and mica. The two first named materials are rather brittle and would not withstand the enormous pressures caused by unequal expansion, unless special provisions were made to neutralize these forces. Mica insulators, being composed of single washers or rolled in cigar fashion, are very strong, as far as mechanical pressure is concerned, but in an electrical sense they are not so perfect as porcelain or soapstone, as they often permit the current to escape between their layers. In most of the modern plugs the insulator is laid back far enough into the body so as to be out of the direct heat of the explosion. Furthermore, the parts are fastened by elastic means in order to relieve the strains caused by expansion.

The settling of soot, oil or water upon the plug can not be avoided by its shape or materials. These injurious substances are produced by the motor, and the causes should be removed. Every plug will soil if the motor works under corresponding conditions. The quality of a plug depends upon the length of time which elapses before it becomes unfit for work on account of soiling. A good plug should be of robust construction, the exterior part of the insulator should be strong enough to withstand the unavoidable rough usage, its size and shape should be chosen properly to prevent the exterior passage of the current, even if occasionally a higher voltage is used. The spark points should be disposed in a safe place, where they are not easily knocked off. A very desirable feature is the presence of a good-sized hexagon part to apply a common wrench without touching the insulator. Soft packing materials for the joints must be avoided, as they are not durable, and are liable to change the position of the electrodes. The various parts should be easily accessible for cleaning and repairs.

Out of the multitude of plugs that are of-

ferred by the dealers, only a few shall be considered here, in which some of the desirable properties are realized.

The plug "Luthi Veritas" is illustrated in Fig. 8. The body (1) is made of steel; it is bored out to receive the taper porcelain insulator (2), which is carefully ground to make a perfect joint. It is fixed in place by the steel nut (3), which presses upon the soapstone ring (4); by the intervention of a copper gasket (5) a pure nickel pin (6) forms the insulated electrode. The shoulder (7) is ground upon the porcelain piece. The thin nickel plate (8) emits the sparks that jump between this plate and the notched face of the nut (3). The electrode is fastened by a clamp nut (9), and the nut (10) serves to attach the wire. The elastic steel washer (11) permits the free expansion of the parts. Notable in this plug is the simplicity and perfectness of the joints. The electrode (6) is well centered, and the spark gap is thus inalterably fixed. The insulator is well away from the heat; it is especially protected by the soapstone ring (4), which also prevents the entrance of oil.

The plug of the Pittler Works was especially designed to work in connection with

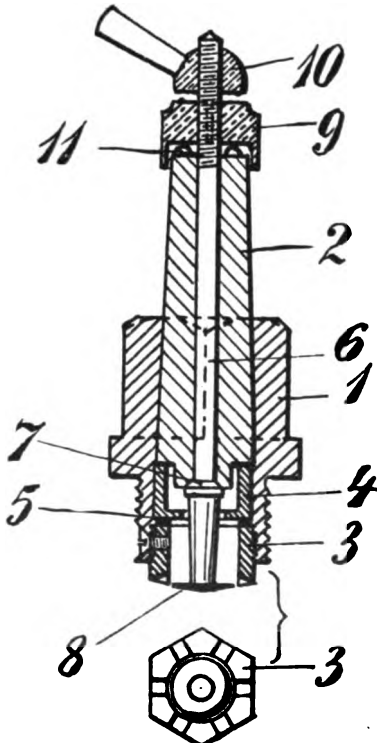

Fig. 8

their generator and interrupter. The drawing, Fig. 9, shows its construction clearly. A pure nickel spindle (1) passes the porcelain body (2) and a long square nut (3). It carries a platinum point (4), and is fastened to the insulator by a nut (5) and lock nut (6). Its ball-shaped head (7) serves to fasten the cable by means of the clamp (8). A thin nickel plate (9), pierced by a central hole, covers the hollow of the body (10). The inventor claims for this plug that the combustible mixture pressed into the chamber (11) by the force if the compressor is ignited first. The flame of this initial combustion shoots out of the little hole in plate (9) like a flash of fire, and thus causes a quick and powerful explosion of the main charge. The plate (9) shields the insulator from oil and excessive heat; the position of the electrode may be adjusted easily from the outside, and the whole plug is easily dismantled.

The plugs "Sandor" are very similar in general construction to the preceding plug. The main difference is in the head of the insulated electrode. This is cup shaped, the rim of the cup having a number of coarse teeth which are bent towards the body of the plug and form several spark gaps. The cup is pressed of sheet nickel. It becomes very hot, and, consequently, burns oil immediately. Being riveted to the end of the electrode pin, it is liable to get loose and cause short circuit. Except for this defect, which might easily be remedied, this plug works very satisfactorily. Its insulation is made either by a porcelain or soapstone piece of equal shape and interchangeable.

The "Bosch" plugs have two small taper soapstone insulators, which are ground oppositely into the body of the plug and drawn together by a shoulder on the electrode pin and two nuts. The pin itself is wrapped with sheet mica. Its head has six star-like extensions, which stand partly opposite to six projections of the body. The distances of the spark gaps may be varied by turning the central electrode somewhat.

In another type of the same maker the inner end of the electrode pin is split so as to show four finger-like projections. The electrode with the two insulators is contained in a special steel piece, which may easily be unscrewed and withdrawn from the plug body for inspection and cleaning.

The "Bosch" plugs are light and simple in construction, and are made to co-operate

with the magnetos of the same maker. They are rather sensitive to oil, however, and should be avoided in the best room. If oil can be kept away, they work splendidly.

The "Eisemann" plugs are made with compressed mica insulators. In one type a short porcelain tube is placed at the inner end of the plug, in order to combine the perfect insulating qualities of the china with the strength of the mica. Contrary to all the aforementioned plugs, which are entirely concentric in the arrangement of all their parts, the "Eisemann" plugs have one central electrode, while the other one is formed by a thin wire screwed into the rim of the plug body, similar to the time-honored De Dion plug. They are very durable, except for this wire, which is easily knocked off. As far as their sensibility to oil is concerned, they are just like the "Bosch" plugs.

French experts declare the "Pognon" plug to be the best. Certainly it might be a good one, for it is high-priced. It possesses about all the features which are considered injurious, and are avoided in the other successful plugs.

It is not simple at all, having three porcelain insulators of different shapes. Two of them are of comparatively plain shape and are removed from the heat. The third one, however, is very fragile, and just this one is exposed to the explosion nearly all around. Its electrodes are of thin wire and are very tender.

And yet this plug is recommended by all the leading automobile builders of France, Belgium and England. In this case theory and practice are entirely at odds.

The exterior spark gap appliances which caused quite a stir when they first made their appearance, and were believed to be the panacea for all ignition troubles, as far as the plugs were concerned, have not fulfilled their promise. No doubt their application causes an intensification of the current, whereby it is enabled to overcome certain resistances in the plug which otherwise would interrupt it altogether. Really, the spark gap shows only that the current supply is in good shape. If the plug itself is short circuited in some way, the exterior spark will continue to appear every time the circuit is closed by the motor. If, however, no spark is visible, it is a safe sign that the plug also fails to work. This device is of only restricted utility, and more of a toy. But as there is a demand, these spark gaps

are supplied at prices ranging from three cents up to about one dollar apiece. Fortunately, the cheap appliances, the open spark of which is no doubt responsible for many a disastrous fire, are fast being replaced by more perfect ones. In the modern styles the spark points are neatly encased in a strong glass cylinder and a slotted brass tube, or they are arranged in a metal box with a glass front. Sometimes one spark point is made adjustable. Several manufacturers produce direct combinations of the exterior spark gap device and the plug; others venture a step farther and place both spark gaps within the cylinder with the intention of utilizing both sparks for ignition. Of course, this is possible, but the chief advantage, the visibility of the spark, is lost. As both sparks are exposed to exactly the same vicissitudes, they will probably fail at the same moment.

On the test stand the frequent failures of ignition on account of an excess of oil are very troublesome. But as the liberal use of oil can not be avoided in a new engine, it was necessary to protect the plug from the oil in some simple way. In some motors the plug has been placed so as to be out of the

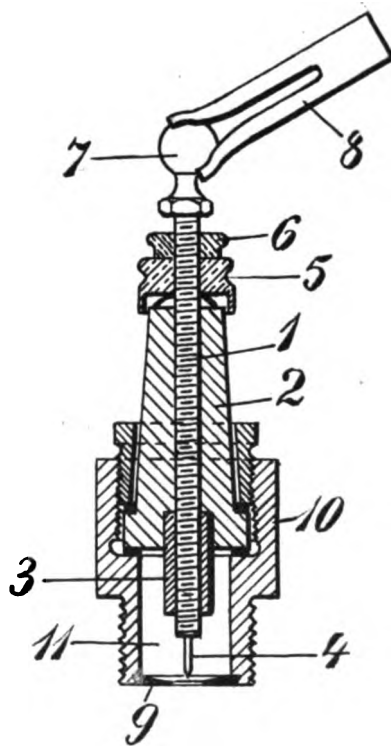

Fig. 9

direct path of the particles of oil splashed about by the movements of the piston or the gases. A separate little ignition chamber is provided, and connected to the main explosion chamber by an orifice of comparatively small area. The celebrated De Dion Motor Works are said to use a short elbow pipe between the motor and the spark plug when testing the motor. The little contrivance shown in section in Fig. 10, called spark examiner, embodies the same principle as the De Dion test stand tool, and possesses some other interesting features. The cubical contents of the small cross pieces do not materially influence the ratio of compression, being about $1\frac{1}{4}$ cubic inches only. The improved reliability of ignition and the possibility of observing the spark under actual working conditions are especially valuable for the test stand, and may serve to enlighten the operator about many secrets of the gas engine.

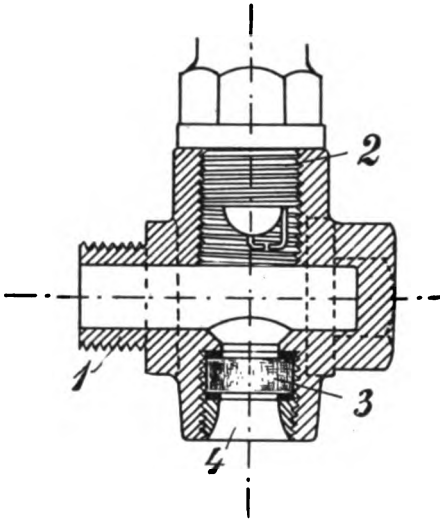

Fig. 10

The aforementioned spark examiner consists of a bronze cross piece. The shank (1) is threaded and screws into the spark plug tap of the working cylinder. The branch (2) is tapped to receive a jump spark plug. Opposite to the latter is arranged a window of strong plate glass (3), which permits the examination of the spark, as long as the glass is not sooted. The unsupported area of the glass is only $\frac{3}{8}$ inch in diameter, and as it is held between two elastic gaskets, it is not liable to crack. It may easily be cleaned by unscrewing the spark plug and replaced by removing the nut (4). The author made a number of tests with this lit-

tle apparatus. He used it on a two-cycle engine, which by the negligence of an attendant had been flooded with oil. The spark plug covered with oil after a few revolutions, and the motor stopped. When the spark examiner was applied the motor started easily and missed no explosion at all at 750 r.p.m. After a while it was stopped and the parts investigated. The entrance of the shank (1) was partly coated with a sticky mixture of soot and oil. The other space of the casing was absolutely clean, and so was the bottom of the plug and the sight glass.

In the course of another test the sight glass cracked, probably on account of a drop of water thrown from the brake, but yet the four fragments of it did not blow out nor allow the pressure to leak out, though one of the pieces became red hot. As the casing becomes very hot, any oil entering it is probably burned right away. A change of the moment of ignition on account of the comparatively long port could not be discovered.

It was really a fascinating sight to watch the spark light up like a minute white dot of extreme brightness. Almost simultaneously a pale violet light filled the entire space of the casing, indicating the ignition of the charge.

The color of the light permits one to judge of the quality of the charge, and gives interesting pointers not only of the working of the vaporizer, but also of the governor.

If the combustion is scarcely visible and the flame tinged a pale blue, there is a lack of fuel, but if the charge is too rich, the light is of a bright vermilion or orange color.

Thus the spark examiner shows the conditions of ignition as well as of the other important functions of the motor. It is not only a valuable test stand accessory, but may also prove of great utility in many other cases.

It also offers a chance to control the behavior of different magnetos or spark plugs, and to find out their relative merits by direct observation under the conditions of regular work.

The fixed insulated electrodes for make-and-break ignition are now made frequently similar to jump spark plugs. A stout steel pin is surrounded by a mica insulation. The latter is fastened in a steel or bronze body, provided with a suitable thread and a hexagon part. The central pin terminates in a

head of large diameter, which enters the cylinder. To the outer end of the pin the cable is fastened. The mica insulation is sufficiently strong to withstand the constant hammering of the interrupter lever upon the head of the electrode; the latter is rigidly centered, and, being of large size, offers little resistance to the passage of the current and is very durable.

Complete electrodes of this description are furnished by most of the leading spark plug makers. They are made in a variety of shapes, and may easily be adapted to every type of motor. Being self-contained, nice looking and cheap, they replace advantageously the clumsy home-made igniter pins previously used. These electrodes are easily and quickly removed for inspection; cleaning is very easy, as there are only plain and smooth surfaces. The mica insulation is nearly indestructible, and is doubtless the best material for the low tension current.

A connecting link between the make-and-break method of ignition and the jump spark system is the magnetically operated igniter, which has appeared upon the market only recently.

Two types of it, both of French origin, have undergone severe tests, and have proven their reliability and durability. These igniters are related to the jump spark plug in so far as they are fixed to the motor cylinder in the same manner by a threaded shank, they receive the current by a single wire from the generator, and no mechanism is required. But, contrary to the jump spark plug, the magneto-electrical igniter operates on low tension current and produces the spark by rupture. Any one of the usual generators of electric energy may be used to furnish the current; a spark coil is not needed.

The igniter "Caron" is very similar to a common spark plug in size, as well as in exterior appearance.

The steel body of this novel plug is hollow; its front part is threaded to suit the standard plug thread of the motor cylinder. A diametrical bar across the front face carries exactly in the center of the plug a platinum contact tip. A short brass tube centrally fixed to the body, but well insulated therefrom by a porcelain ring and mica washers, serves to guide a contact bar. A spring rests upon a shoulder of the contact bar and presses it against the platinum tip. The upper part of the bar, which is encir-

led by the spring, enters the bore of a soft iron plug that forms the axial prolongation of the aforementioned brass tube. Both these latter pieces are surrounded by a coil of fine insulated wire; the coil is protected by a metal shell.

Wherever a kick of current is sent through the coil the iron core is magnetized; it attracts the central contact bar against the tension of its spring. The circuit is broken at the platinum tip and a fat spark appears. By the interruption of the current the core demagnetizes at once, and the contact bar is pushed back by its spring.

The weakest parts of the "Caron" plug are the sliding contact bar and the spring. Both lie in the combustion chamber and are exposed to great heat and much dirt. Thus the bar is liable to get stuck, as soot and grit will settle upon the sliding surfaces, and the spring will soon lose its elasticity. A special magneto has been designed to furnish the current for this igniter. It is of the rotary type, and, as it has four poles, it gives four emissions of current during one revolution of its armature. By a simple form of wiping distributor fastened upon the shaft of the magneto, the current is sent to each plug by a separate wire.

The igniter H. T. Z. is like in its working principle to the afore-described "Caron" igniter. Though it is not so neat in appearance, it is much better in mechanical detail. It has only one movable part, a double armed lever, pivoted exactly in its center of gravity. It is hinged lengthwise in the hollow of the plug body. The bearings for the pivot pin are insulated by porcelain bushings. One end of the lever, the one next to the motor cylinder, is armed with a nickel shoe that strikes a flat block fixed to the shank of the plug. The other end of the lever is flattened out. Two coils are placed opposite and at a right angle to the axis of the plug. Their iron cores enter the body of the plug and terminate quite close to the flat head of the contact lever, allowing it to move only the short distance between the two poles. At their exterior ends, outside of the coils, the cores are connected by four U-shaped thin strips of soft iron, forming one double poled electro-magnetic combination. When the current is sent into one of the coils, its core is magnetized; the flat head of the contact lever is attracted and its opposite head is drawn against the

nickel block. Next, the current passes the other coil; its core pulls the lever in the opposite direction, the contacts are separated and the sparks formed.

By the use of two coils, one for the contact, the other for disruption, the return motion of the lever is obtained without a spring. The lever moves nearly frictionless and can not be impeded by dirt. The coils are exposed to the open air all around and are not heated unduly. The whole plug is entirely pressure-proof, and not liable to leak.

Electro-magnetically operated igniters are too new yet; time only will decide whether they can compete seriously with the other well-tried systems or not.

Make-and-break igniters and their mechanisms can not be described here. They are in a state too unsettled and too manifold in design to be classified intelligently. They will, therefore, be treated in a later part of this discussion, as occasion arises, and in connection with the motors they form part of.

Before the chapter on ignition is closed a few remarks of a somewhat statistical character may give an idea of the frequency of the main ignition systems. The figures have been compiled at the late Paris show.

As the Paris Salon is the principal meeting place for the automobile industry of Europe, the figures obtained there will probably be a fair average. Of all the cars shown, 26 per cent were equipped with make-and-break ignition and a low-tension magneto; 23 per cent had direct jump spark ignition, supplied by high-tension magnetos; 19 per cent ignited by jump spark plugs for which the current was furnished by storage batteries; 32 per cent have double ignition system, a magneto and a storage battery combined.

This item is of interest insofar as it shows that the presence of a reserve source of electric energy is considered necessary in a powerful motor car. It is a feature that gives additional security against failures of ignition. It shows, furthermore, that the designer yet feels a certain distrust against the modern magneto, perfected though it be.

No doubt the magneto for direct jump spark ignition will undergo many improvements, yet before it entirely dispels the suspicions of the cautious designer.

The author would be highly gratified if his criticism and suggestions could in any way contribute to attain this desirable result.

(To be Continued.)

K N A B E N S H U E ' S A I R S H I P

During the fall of 1904 the public began to read in the daily papers of A. Roy Knabenshue, whose home is at Toledo, O., who successfully maneuvered Captain Baldwin's airship, "Arrow," at St. Louis during the exposition. During the last summer more has been heard of this young man, who has been very successful in making ascensions with a ship of his own design. At Toledo, in June, at New York, in the middle of the summer, and at Columbus, O., the first week in September, he attracted widespread attention. Just as this issue is going to press he is expected to repeat his success in the vicinity of Cincinnati.

The "Toledo II.," as his present airship is named, consists of a 62-foot gas bag, which supports the framework carrying the motive power and the motive and steering apparatus and the navigator. This bag is cigar-shaped, rounded at the rear end, but pointed at the front. The designer claims that by his construction of the gas bag there

is little or no shifting of the gas, thereby avoiding pitching. About 7,000 cubic feet of hydrogen is required to inflate the bag, which weighs but 65 pounds.

The framework, 38 feet long, is constructed mainly of spruce and bamboo. It weighs about 200 pounds, including the entire apparatus on it. The propeller is located at the front and pulls, rather than pushes, the ship. This propeller, which is two bladed, is made of spruce, covered with fine muslin. It weighs about seven pounds, and during the flight is usually run at a speed of 180 r.p.m., at which speed the propeller thrust is about 35 pounds.

The 10 H. P. engine, which furnishes the motive power, is air cooled, four-cylinder, and has a bore of $2\frac{1}{4}$ and a stroke of 3 inches. It has run at as high a speed as 2,160 r.p.m. Its connection to the propeller shaft is by means of a sprocket and chain, the ratio of the engine to propeller shaft speed being 6 to 1. Varying the time of

ignition varies the speed of the engine, as there is no attempt at throttling the mixture. The weight of the engine, including shaft clutch, batteries and tank, is but 92 pounds. The supply tank has sufficient capacity for a five-hour sail. About fifteen

miles per hour is the estimated speed of the airship.

Mr. Knabenshue does not claim to have solved the question of the commercial airship, but has shown that a balloon may be navigated under favorable conditions.

THE McCLELLAND OIL PURIFIER

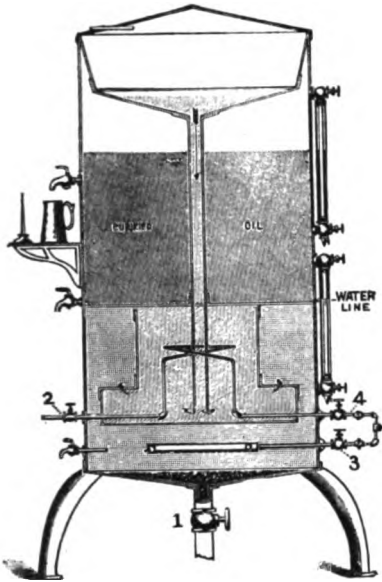

On every hand we find the greatest efforts of inventive minds directed toward the prevention of waste, and especially as this occurs in the care and operation of machinery. The item of oil is an important one in this connection, and various methods have been devised whereby oil may be reclaimed by mechanical means after having served its original purpose, and so made available for use again. The reduction in the oil bill which has been effected in this way represents a considerable saving. More than this, oil from which all foreign substances has been eliminated by means of purification before being used at all, insures an appreciable economy in the wear and tear and consequent life of the machinery itself.

The McClelland improved oil purifier is claimed by its users to offer the most practicable and desirable means of oil purification.

The sectional view on this page is largely self-explanatory, but we may add that

connection should be made at valve 1 with the sewer, and at 3 and 4 with the steam, the exhaust connection being made at 2.

The operation is decidedly simple. The purifier is filled 1-3 with water, which is gently warmed by steam at 4. The impure oil is thrown into the top chamber A, and passing by gravity through a strainer B, gradually finds its way into and down the vertical pipe C, which is in the center of the tank, mixing with the water D in the bottom.

The inverted bell prevents the dirty oil in D from rising to the top of the water, while the heat from the steam coil forms fine oil globules from the mass which gently rise as cream rises on milk, the sediment, grit, dirt and all impurities heavier than the water are readily precipitated and drop to the bottom.

From this chamber D, the oil passes out at the bottom and through outlets, as shown by the two small arrows, into chamber E, where it is washed by passing through the water. Around the outside and flush with the top of the bell, is a wire gauze screen which prevents such impurities of the same specific gravity as the oil from rising with it into the storage reservoir above, marked "Purified Oil."

The body of the machine is of heavy rolled galvanized iron with a patent seamless bottom resting upon cast iron legs. The fittings are of brass and the oil gauges self-cleaning. The McClelland device not only purifies oil as received in the original package, but removes all injurious substances which may accumulate from use in machinery so that pure oil is constantly on hand.

The McClelland machine is not a filter, but an oil purifier. It is made in two sizes, to hold one or two barrels, as desired. Messrs. Patterson, Gottfried & Hunter, Ltd., 150 Center street, New York City, will be pleased to send booklet containing full particulars on request.

ANSWERS TO INQUIRIES

It is our purpose to answer in this column inquiries of general interest which relate to the gas engine or its accessories. The questions will be answered in these columns only, and we reserve the privilege of refusing to answer any question which is not, in our judgment, of interest to the subscribers of THE GAS ENGINE.

All matter intended for this department should be addressed to The Editor of THE GAS ENGINE, Blymyer Building, Cincinnati, Ohio. The name and address of the sender must accompany the inquiry in all cases as evidence of good faith. The initials only of the sender will be published, together with the postoffice and state.

Write on one side of the paper only, and make all sketches and drawings on a separate sheet. Mark each sheet with the name and the address of the sender.

Will you kindly answer the following questions in regard to a two-cylinder opposed, 3×3 in. two-cycle engine of the three-port type? (a) What size should the parts be to run at 1,500 r.p.m.? (b) I intend using a separate cylinder instead of the crank-case to supply the working cylinders. Should I make the top edge of crank-case inlet come even with the bottom of the piston when the latter is on the inner dead center? (c) What size crank shaft and flywheel should I use? (d) Which would be the better balanced engine—one in which the explosions in both cylinders occurred at the same time; that is, a double impulse every other stroke—or one in which the explosions occurred alternately; that is, a single impulse every stroke? I think the former would be, but would require a little heavier flywheel to carry over the idle stroke. (e) If I use kerosene that is vaporized before entering the cylinder, how much compression should I use? (f) What percent of the total cylinder volume or of the piston displacement should the compression space be when using kerosene for fuel? (g) When using gasoline? (h) About what power should I get on each?—P. J. C., Dobbs Ferry, N. Y.

(a) Exhaust $\frac{1}{2} \times 1\frac{1}{2}$ inch, inlet $\frac{3}{8} \times 1\frac{1}{2}$ inch, bottom edge of ports even with ends of piston when latter is at the inner center. Crank-case port, if used, $\frac{1}{2} \times 1\frac{1}{4}$

inch. (b) We see no necessity of employing a separate cylinder for an air pump, as the crank-case performs this function very well. The edge of the inlet farthest from the crank shaft should be even with the inner edge of the piston when the latter is at its outer dead center. Use only one inlet for crank-case. (c) Crank shaft 1 3-16-inch diameter, flywheel 12-inch diameter, about 60 pounds. (d) Make the crank pins 180 deg. apart, so both explosions come together. (e) We have found that the compression for gasoline works very well with kerosene. (f and g) 30 per cent. (h) About 6 H. P. on gasoline and $6\frac{1}{2}$ H. P. on kerosene.

(a) In a boat 25 feet long, 6-foot beam, and 18 to 22-inch draft, what size motor would be required to get 10 miles per hour? (b) what size propeller should be used?—W. O., Philadelphia, Pa.

No definite answer to this question can be given without knowing the lines of the boat. However, we judge that from 12 to 15 H. P. would be necessary with a boat of such a beam. (b) For a high-speed multiple-cylinder engine about 18 diameter.

(a) What is the best point for opening and for closing the exhaust and inlet valves of the four-cylinder, four-cycle marine engine, $8\frac{1}{4}$ -inch bore by 9-inch stroke, running at 450 r.p.m., and also when running at 500 r.p.m. (b) What should be the lift of each valve and what should be the diameter for best results? Is 3-inch diameter large enough? (c) There is only $2\frac{1}{2}$ -inch clearance on top of the piston with no valve chambers, the valves being in the head. Is this correct? (d) What should be the diameter of the inlet and the exhaust pipe? (e) Is it possible to get as much power by the exhaust of the four-cylinder into one pipe, or should two independent pipes be used? If so, how should they be arranged? (f) Is 450 to 500 r.p.m. fast enough to gain anything by holding the exhaust valve open past the top center, as advocated for automobile engines. (g)

Is there any gain with a mechanical inlet at that speed.—F. R. K., Sag Harbor, New York.

We should open the exhaust $\frac{7}{8}$ -inch in advance of the end of the expansion stroke and close it at or slightly beyond the top center. Open the inlet valve slightly after the exhaust closes and close it $\frac{1}{4}$ -inch up on the compression stroke. (b) At 450 r.p.m. the inlet should be $2\frac{3}{4}$ -inch diameter and the exhaust 3-inch diameter. At 500 r.p.m. make the inlet 3-inch diameter and the exhaust $3\frac{1}{4}$ -inch diameter. Make the lift in each case at least $\frac{1}{4}$ the diameter. (c) This is about right allowing for counter bore. (d) Use pipes with opening equal to the valves of 3-inch pipe in each case above. (e) There is no advantage that we know of in using more than one exhaust pipe. (f) On this size engine we think there is a slight advantage. (g) We advise the mechanical inlet by all means.

Please give me the rule for figuring out the sizes of cylinders for gas engines and oblige.—J. W. C., Warren, Pa.

Let D =diameter cylinder in inches.

Let L =stroke in inches.

Let R =r.p.m.

Let N =number of cylinders.

Then $\frac{D^3 \times L \times R \times N}{12,500}$ =H. P. of four cycle engines.

Then $\frac{D^3 \times L \times R \times N}{15,000}$ =H. P. of two cycle engines.

These denominators are for gasoline. For natural gas use 14,000 for two-cycles and 17,500 for four-cycles.

(a) Will you kindly give me the sizes of the inlet and exhaust valves, of a four-cycle engine of 4-inch bore and $4\frac{1}{2}$ -inch stroke, to run 1,200 r.p.m.? What should be the height in inches of the compression space, and what H. P. will this engine develop? (c) What is meant by the pitch of a propeller?—F. B., Adams, New York.

Inlet valve opening 1 9-16-inch diameter, exhaust valve opening 1 11-16-inch

diameter. It is customary to make both valves the same size and we would suggest $1\frac{1}{8}$ -inch diameter for each valve. (b) With valves opening directly into cylinder and no valve box, 1 5-16-inch long. (c) The distance the screw would move in a fully resisting substance at each revolution. It is the same as the pitch of a thread on a bolt.

I have an automobile in my shop. I have been putting in a new shaft, but the engine does not have power enough. The compression is very good, the engine starts easy. When I open the carbureter the engine slows down instead of speeding up. The spark seems good. I have changed batteries. It used to be a powerful car. I timed the cam to open exhaust, as it is going over the center, the intake the same.

We think perhaps the best thing for you to do would be to get an automobile expert to look the machine over. The trouble is probably in the carbureter. If the machine gets too much gasoline when it is opened adjust the needle valve. If it gets best results at high speed and does not get enough fuel at low speed, make the point of the needle sharper.

I have a two-cycle gas engine $4\frac{1}{2} \times 4\frac{1}{2}$ -inch on a launch. I sent this engine to a machine shop and had the cylinder bored and a new piston and packing rings put in, and since then I can not get it to run. It will make a few revolutions, then explode in the base and stop. There are two packing rings on top end of piston, but none on the lower end. The machinist that repaired this engine says it is not necessary to have a ring on the lower end of piston, but I think it is. The piston is a little smaller in diameter than the bore of the cylinder and I think it is possible that when the piston is on its upward stroke that some of the exploded charge would be drawn in the base, and that is what causes the explosions in the base. Please let me know whether I am right or not, and oblige.—W. J. F., Patterson, La.

One of the most important things in a gas engine is the fit of the rings and the piston. The rings especially should bear all around the bore of the cylinder and

against the sides of the grooves. There should be at least three rings at the top of the piston, but none at the bottom. These rings should require at least 18 pounds pressure to force them together

to the size of the cylinder. The piston should be a snug fit in the cylinder, so that it can just be pushed through by hand. Your explosions may be due to leaks, weak mixture or late ignition.

TRADE PUBLICATIONS.

Fairbanks, Morse & Co., Chicago have a special engine catalogue showing a number of installations of this character.

A circular from the Sims Co., Erie, Pa., shows the Sims oil filter, for which special simplicity in construction is claimed.

A mailing card from the Hart-Parr Company, Charles City, Ia., shows one of their traction gasoline engines operating a saw-mill.

Catalogue 45, of Patterson, Gottfried & Hunter, Ltd., 146 Center street, New York, lists a full line of power transmission appliances.

"National Sparkers," National sparking batteries, are the subject of a circular received from the National Battery Company, Buffalo, N. Y.

Forgings in iron and steel are tested in a catalogue of J. A. Sundberg Company, Kinzie and Carpenter streets, Chicago. Crank shaft and connecting rod forgings are made a specialty.

Bulletin No. 130, of the Dayton (O.) Manufacturing Company, relates to isolated electric light plants, combining the use of gas engine driven generators and Silvey storage batteries.

A catalogue of suction gas producers from Dr. Oskar Nagel, 90 Wall street, New York, N. Y., describes the method of operation of these producers and shows the economy in cost of operation.

The Columbia Steel Company, Elyria, O., is distributing a neat celluloid novelty in the nature of a table of standard wire gauges with equivalents in decimal parts of an inch and weights.

Patterson, Gottfried & Hunter, Ltd., 146 Center street, New York City, are sending out blotters containing an advertisement of the McClelland oil purifier, which is fully described in other columns of this issue.

A folder issued by the Field-Brundage Company, Jackson, Mich., contains considerable interesting information relative to their engines, in the shape of questions and answers.

A new catalogue of Clifton marine engines is just being distributed by the Clifton Motor Works, 227 E. Clifton avenue, Cincinnati, O. These engines are fully described in another column.

W. B. Murray, 1253 Milwaukee avenue, Chicago, Ill., describes his transmission gears in a four-page circular.

The Atwater Kent Manufacturing Works, 42 N. Sixth street, Philadelphia, Pa., are sending out circulars showing the Atwater Kent timer, for one to four-cylinder motors, the Atwater Kent automobile switch, pocket meters, etc.

Nielson Duplex Engines are described in a small 20-page catalogue from the Nielson Motor Works, St. Joseph, Mo. These engines are of the two-cycle type and are built in single, double and triple cylinder units from 3 to 25 H. P.

A circular from Fox's Reversible Engine Works, Covington, Ky., describes their marine engines, for which the claim is made that "the engine will positively start without turning over center, and a man with no hands can start this motor."

A catalogue from the Lima Gas Engine Company, Lima, O., shows the Lima gas and gasoline engine, which is built in units from 2½ to 100 H. P. These engines are of the type employing a cross-head connection from piston to crank shaft.

"Hudson" gas and gasoline engines are shown in the catalogue of the Motor Engine Company, 15 William street, New York, N. Y. These engines are of two-cycle, vertical type and employ some novel features which we expect to illustrate in an early issue.

The Steffey Manufacturing Company, Philadelphia, Pa., send a small catalogue showing the Steffey motor for motor cycle, automobile, marine and stationary use. It is said that this company was the first American manufacturer to market a motor bicycle, having placed their first motors on the market January 1, 1900.

The catalogues received from time to time from the De LaVergne Machine Company, New York, N. Y., are always illustrations of some of the best work that can be gotten out by first-class printers. The latest catalogue from this company, describing

their Hornsby-Akroyd oil engines, is no exception to the rule. Printed in two colors, illustrated with excellent half-tones, sectional views, etc., it is a very fine piece of work.

"Goes and Goes Right," is the phrase which the "New-Way" Motor Company, Lansing, Mich., uses to describe their engines. These engines are all air-cooled and the method used is to provide the engine with a large number of radiating flanges which are perforated and connected together with about 500 radiating bars, which not only strengthen the flanges and prevent breakage, but also increase the surface.

INDUSTRIAL ITEMS.

The Continental Motor Company expects to move November 1 to Muskegon, Mich., from Chicago.

On September 2 McDonald & Erickson marine engines won first and second prizes at Waukegan, Ill.

It is reported that the town of Weyburn, N. W. T., is considering the purchase of gasoline fire engines.

The Power Company, Hampton, N. B., has been incorporated with a capital of \$24,000 to manufacture gas producers, engines, etc.

The Power and Gas Machine Company, Galt, Ont., have been incorporated with a capital of \$100,000, to manufacture gas generators, gas producers, air engines, etc.

The Axelsen Machine Company, Los Angeles, Cal., is reported as contemplating the erection of a two-story 42x155 brick addition to its factory for the manufacture of gas engines.

The Dean-Waterman Company, Covington, Ky., have recently purchased a site on the Ohio River, at Newport, Ky., right across the river from Cincinnati. Their foundry and gas engine factory will find increased accommodations in the new factory, which is expected to be ready for occupancy November 1. This company is just adding a line of marine engines, and the new location will give them excellent facilities for testing, etc. There will be about 45,000 square feet of floor space in the factory.

The Toronto Launch and Engine Company, Ltd., of Toronto, has been incorporated for the purpose of dealing in boats, launches, steam and gasoline engines, etc., and to take over the engine patents and applications for patents from J. C. McLachlan.

This is the season of the year when the gas engine manufacturers begin to get ready for cylinder jacket repair jobs. Don't forget that your cylinder may be burst by the first frost of the fall. It is more economical to drain the cylinder water from the jacket than to have a crack repaired.

Did you ever try to figure out why some spark coils cost so much less than others?

Do you know that on what goes into these coils depends the success of your ignition system?

Did you ever notice that your ignition fails if your coil gets wet?

A Texas automobilist had an air-cooled motor which gave him trouble from overheating. He reduced the quantity of lubricating oil to one-fourth its former quantity by placing a nine-gallon tank of water over the cylinder and arranging so that a slight stream of water played on the cylinder head.

The I. X. L. Steam Packing Manufacturing Company, 96 Spring street, New York, have brought out a new packing which they claim is unequalled for its resistance against heat, acids, oils, etc. It can not be passed out from between the flanges, nor will it burn and stick to them.

Mr. Dugald Clerk says that cylinders up to 18 inches in diameter are cooled most economically by keeping the cooling water in the jacket at about 175 degrees Fahr. Pistons up to 22 inches in diameter could be run without water jacketing, even though reaching temperatures of 1,300 to 1,475 degrees.

The Canadian Pacific Railway is reported as putting into service special railway motor cars for individual passengers. The cars are automobiles fitted with special wheels to run on the railroad tracks, the cars are handled by train dispatchers, and, in effect, they are special private cars.

The Continental Engine Company, of Chicago, Ill., have just purchased elabo-

rate cylinder boring and finishing tools to facilitate the rapid duplicate manufacture of their motors, which are adapted to all classes of service. The new office and factory are located at the corner of Kinsbury and Huron streets, Chicago, and the new concentration of their forces, together with the additional equipment, will add materially in specialization for manufacturing in quantities.

The manufacturers of the American Diesel engines say that the average weight of their engines run from 220 to 288 pounds per H. P. without fly wheels. The weight of the fly wheel depends on the number of cylinders, which are from one to six in number, but the average fly wheel weight is from 30 to 50 pounds per H. P.

DE DION ENGINE DIMENSIONS

Engine designers are greatly interested in learning the dimensions of various makes of engines, not necessarily to copy them or for any illegitimate reason, but largely for comparison. We believe that if most of the engine manufacturers were more liberal in publishing information of this kind, it would result in good not only to themselves, but

The Automobile recently published the accompanying dimensions of the De Dion & Bouton motors. This French firm was among the pioneers in the automobile line. The inlet and exhaust valves are of the

same size, and the former are mechanically operated. The last three units are twin cylinder types; the others are single cylinder.

H. P.	Con. Rod Valve				Weight lbs.	R.P.M.
	Bore in.	Stroke in.	Lgt. in.	Dia. in.		
1 1/4	3.44	2.75	7.08	.98	50	1,800
1 1/2	3.59	2.75	7.08	1.18	53	1,800
2 1/4	2.75	2.75	7.08	1.18	55	1,800
2 1/2	2.91	2.99	7.28	1.25	57	1,800
3 1/4	3.14	3.14	8.56	1.33	99	1,800
4 1/4	3.3	3.54	8.77	1.49	110	1,800
6	3.54	4.33	9.94	1.49	132	1,700
8	3.93	4.33	9.94	1.65	143	1,600
8	3.93	4.72	10.78	1.65	187	1,550
10	4.23	5.11	11.23	1.81	187	1,500
10	3.54	4.33	1.65	172	1,500
12	3.93	4.33	1.65	172	1,500
16	4.09	5.11	1.81

NON-FREEZING SOLUTIONS

1. Use a mixture of four parts water and one part wood alcohol. The difficulty with this method is that the wood alcohol tends to evaporate out from the water and has to be replaced, from time to time.

2. Use a nearly saturated solution of calcium carbonate. The difficulty with this solution is that it has a slight tendency to corrode the metal it comes in contact with.

3. Use a mixture of four parts water and one part glycerine, to which should be added about pound of ordinary washing soda for every ten gallons of the mixture, to correct a slight tendency toward acidity from the glycerine.

It is possible to freeze any one of the above mixtures if the temperature is sufficiently lowered, but none of them is likely to freeze at a temperature above about zero Fahr. Any one of the three mixtures will give satisfactory results, but in our judgment perhaps the third is the best.

If a mixture is desired for a temperature below zero degrees, we would recommend adding wood alcohol to the third mixture. While we have had no experience with this, we believe it would give good results.—*Scientific American.*

THE GAS ENGINE.

STATIONARY—AUTOMOBILE—MARINE.

PUBLISHED MONTHLY BY

The Gas Engine Publishing Co.

Blymyer Building, Cincinnati, Ohio.

ADVERTISING RATES ON APPLICATION. Address All Communications to the Company.

Entered at the Postoffice at Cincinnati, Ohio, as Second Class Matter Feb. 20, 1899.

VOL. VII

NOVEMBER, 1905.

No. 11.

Domestic Subscriptions, \$1.00 per Annum.

Single Copies, 10 cents.

Foreign, \$1.50 per Annum. 

We are always glad to receive from engine and accessory manufacturers new catalogues or other advertising literature which they issue. A complete file of these is kept for reference purposes, and we are often able to answer inquiries of prospective purchasers by having a manufacturer's latest catalogues on file. Some of the engine builders also favor us with copies of their books of instructions, which are even more valuable to us in answering such inquiries as come to us from time to time. Manufacturers who have not sent us copies of their catalogues or instruction sets are invited to do so if they see fit.

Under the coal tests being conducted by the United States Geological Survey, coals and lignites are being tested, with the result that it is expected that more than a million dollars a year will be saved the Government in the coaling of naval vessels. Many of these tests will show how to utilize these coals to the best advantage. Gas producer tests, consuming about 10,000 pounds of any given coal, will be conducted for periods of 30 hours at a time. On tests already made, 14 bituminous coals showed a power efficiency in the gas producer plant two and one-half times as great as their power efficiency under boilers. North Dakota and Texas have furnished lignites which show great values in gas producers.

While going through a gas engine factory recently, we were shown an engine which had been built to develop 100 H. P. for marine use. It was a four-cylinder vertical engine, and the builder had never been able to get it to run more than a few minutes. It had recently been sent to this factory to be overhauled and put into running shape, if possible. What appeared to us to be its

most noticeable feature was the use of a bicycle sprocket chain to drive the valve cam shaft from the crank shaft. A small sprocket wheel was used as a tightener. One of the most important things in gas engine construction is to secure a proper timing for the opening and closing of the inlet and exhaust valves. Anyone who has ever ridden a bicycle knows that bicycle chains will wear and stretch. It will readily be seen that in the engine referred to the least wear of the chain, or the least stretching of it, would at once affect the timing of the valves, with the resulting bad effects of a poorly timed engine.

Sometime ago the United States Reclamation Service made some tests at Garden City, Kan., as a basis for making improvements on the present plan for irrigating Western country. A 10 H. P. gasoline engine operated a centrifugal pump for two 16-inch wells located 20 feet apart. The wells were 45 feet deep and had, at the bottom, 14 feet of 18-inch strainer, above which was 11 feet of 16-inch strainer. The water rose in the wells to about 15 feet of the surface of the ground. The pump discharge was 363 gallons per minute, and the natural water level was lowered 6 feet 9 inches. A gallon of gasoline was used per hour. This was figured to amount to \$1.76 for each acre of land covered with water one foot deep. Repairs, attendance, supplies and interest would add another dollar to this amount.

A British Consul in Bolivia recently reported that for the last two years gas engines and gas producers for anthracite coal had been imported into that country from Germany to take the place of steam engines. Coal commands \$40 a ton, making every possible economy of great importance.

THE REASONING GAS ENGINE OPERATOR.

BY ALBERT STRITMATTER.

"Well, that's the end of a gas engine for me. If it will not run any better than that I don't want it, and you can take it out. Here we are with our grain elevator shut down during the busiest part of the day. What are you going to do about it?"

The speaker was the manager and owner of a country grain elevator, and he had purchased, or rather ordered, a gasoline engine, which had been installed the day before. The man who sold the engine did so with the distinct understanding that the engine would be not only successful, but satisfactory, and if it did not prove so he expected that it would be thrown back on him, without even the freight being paid. He had agreed to go and see the engine installed and started, which had been done the day before, and he had even stayed over another day to make sure that everything was satisfactory.

The engine was a small one and the gasoline was kept in the base, and owing to the way the pipes and parts were arranged, one could not easily tell when the tank had a supply of fuel.

The purchaser of the engine asked his question of the dealer, who happened to be there at the time, "What are you going to do about it?" The dealer had had enough experience in such cases not to commit the error of showing them at once (even if he knew it) the cause of the engine stopping. So he told them to go ahead and find out why the engine had stopped. They tested the spark, and so on, but on trying to get gasoline to the inlet valve none could be raised. Then it occurred to the purchaser that no gasoline had been placed in the tank since early the day before, and then there had not been put in a full supply.

The carelessness of trying to run an engine on no fuel has been mentioned so many times in these columns, that it may seem needless repetition to tell this incident. But this case is an actual happening of a few weeks ago, and no doubt occurs more or less frequently, especially among users who are having their first experience with gasoline engines.

It often seems to the writer that if only a gas engine could be gotten up with such arrangements as would result in serious damage when the engine was carelessly handled, that gas engines would be used more. The trouble with a gas engine is that it is too safe. Practically the very worst thing that can happen to it (outside of such accidents as a broken crank shaft, etc.) is that it will stop running, or will run with unsatisfactory results, if it is neglected. Steam plants, on the other hand, require a different sort of treatment.

The carelessness in furnishing the gas engine with proper supplies on which to operate is far greater than it should be, and could the users of many engines appreciate the necessity of using only the best of supplies, and then using them at the proper time and in a proper manner, many engines which are now working improperly would give excellent satisfaction.

The matter of seeing that the gasoline tank is kept supplied with fuel is, alas! only one item of carelessness. Many operators think that this is the only place where consideration must be given: the engine, and this they learn because the engine stops if the conditions are not complied with.

Some months ago the writer learned that a very interesting installation of gas engines, used for operating generators for lighting a store, were giving poor results. Being interested in learning the cause of the trouble, I called there and found a mechanic from the factory going over the engine.

"Look at those cylinders, will you?" was his first remark. The paint on the outside of the cylinders was all blistered and cracked, showing that the engines had been run without being supplied with water. The mechanic stated that on several occasions he had made it a point to go into the engine room when in the vicinity of the store and he had found the engines had been started, but no water had been turned on. Inasmuch as a city cooling water system was used, and as all that was required was to open a

cock in the water supply line, such carelessness was certainly inexcusable. And yet it is being done by many engine users.

The same engineer frequently started his engines without opening up his oil cups, and the result was that the cylinders and pistons became badly worn in a very short time. Is it any wonder that these engines gave trouble? What would have resulted had there been a steam plant in such incompetent and careless hands?

Water (in water-cooled engines), gas or gasoline, and lubricating oil are the main supplies required by this type of engine. Of course there is the matter of renewals of worn parts, an occasional gasket, piston rings, igniter springs, and, finally, the battery and its renewals, when such source of electric ignition is used. For all of these only the best of quality should be considered.

Regarding the supplies of lubricating oils, it is very essential to use a good quality of oil, but it is also desirable to

see that this oil is in its proper place. We often see engines the appearance of which would seem to indicate that the engineer could cut down his oil bills at least half if he would get in the habit of keeping the oil where it belonged, instead of all over the outside of the engine in places where it accumulates dirt and dust and forms a gum to help wear out the engine.

These may seem to some users too small matters to be looked after, when they do not cause the engine to stop. But the most power, the least consumption of fuel, the lowest cost of repairs, the longest life of the engine, and the best running engine depend on the care taken in these small matters. Within the last ten days the writer has had occasion to see a very considerable number of engines of all types and sizes doing various classes of service, and it has seemed to him a most wonderful thing that so many of these engines are doing even fairly satisfactory work with such gross carelessness as has been exhibited by some of their operators.

CORRESPONDENCE.

Editor THE GAS ENGINE—From time to time I have heard of complaints of water getting into gasoline. I have never been bothered myself with this trouble, and wondered how the water ever got into the gasoline. The other day I found out one way. My tank is 120-gallon size and stands in a small house which just contains it easily. The roof is not tight and rain leaks through onto the top of the tank. The tank is flat on top, and access to the interior is obtained by removing a six-inch tin screw cap used for filling. On opening the faucet at the bottom of the tank and drawing out a few gallons of gasoline I heard a trickling sound as if water was running into the tank after I had shut off the faucet. On investigation, I found such was the case. The small quantity of water on top of the tank surrounded the filling cap and covered its edges. On drawing off the gasoline the air pressure on the water forced it through the threads on the cap, which are not supposed to fit tight, and into the tank. The rarefaction in pressure was, of course, caused by letting out a little gasoline. This might also be caused by cold condensing

some of the vapor and sucking in the water when no one was around the tank to hear it. To remedy this I took off the screw cap and punched a small nail hole in the top of the cap to let air in through, but after this I still heard it. The vent was not large enough, since the air pressure to force the water through was so slight and the vent so small it did not give sufficient relief. Remedy, a large vent hole $\frac{1}{4}$ inch or more.—J. W. Chadwick, Lawrence, Kan.

[Water is occasionally caused in gasoline by carelessness in handling or transferring it from barrels to tanks, etc. It may easily be detected by flipping a little of it onto a metal surface. If water is in the gasoline it will run around in small globules like mercury does, whereas the pure gasoline will spread out all over the surface.—Ed.]

Editor THE GAS ENGINE—In your paper of two or three months ago an inquiry in regard to a two-cycle engine was answered by saying that it would be impossible to air cool a two-cycle engine larger than $3\frac{1}{2}$ inches in diameter.

We enclose photograph of a four-cylinder two-cycle air-cooled engine, $4\frac{1}{4}$ -inch bore and stroke. This engine was made and tested in our shop last July, when the thermometer registered 92 degrees in the shade, without fan or other means of cooling, and in a five-hour test we did not get a single premature explosion, and that with the compression at 85 pounds absolute. (Kindly note the compression.)

The photograph with cylinder removed shows why this engine air cools so readily. Instead of using a port in the cylinder

wall, we admit the charge directly through the piston. The valve is opened by a cam on and rotating with the crank shaft. By this method of admitting the charge we feel the limit to air cooling a two-cycle engine without a fan is about an eight-inch bore.

Yours truly,

M'CLURE-BUCHNER Co.

October 13, 1905, Chicago, Ill.

[As will be seen from the photograph, the engine is built with four cylinders, cast separately and cooled by cast ribs.—Ed.]

THE FIVE THOUSAND HORSE POWER GAS ENGINES OF THE CALIFORNIA GAS AND ELECTRIC CORPORATION.*

The very rapid progress in the development of electrical machinery and appliances during the past ten years has invited the capitalist and engineer to install and operate many hundred thousand horse-power of apparatus, utilizing the waters of the various streams as a source for generating the current. The prime incentive for such development from the inventor's standpoint was the fact that the source of power was being constantly renewed by the laws of nature, and with the authentic records of precipitation as a guide, the prudent engineer has recommended a great many plants to be constructed which have proven financially and commercially successful. The most notable examples of this progress have been and are being developed in the State of California. A great many surprises of a practical nature have been encountered by the managers of these various water power electric developments with particular reference to earning capacity, and more particularly with reference to the relations of plant utility to plant capacity, commonly termed "load factor." The manager is constantly trying to find ways and means of utilizing the electric current during times when his present consumers do not require it.

Within the past year the problem was presented to the officers of the California Gas and Electric Corporation, who were desirous of furnishing all the electric current for the operation of the street railroads under the control of the United Railroads of San Francisco, and negotiations

*A paper read before the Pacific Coast Gas Association by John Martin.

were commenced with the officers of the latter company with that end in view. It was very difficult for the railroad people at first to develop even a hope that such a condition of affairs could be made feasible. Here was a company with its thousands of horse-power developed at no point nearer than 140 miles from the proposed place

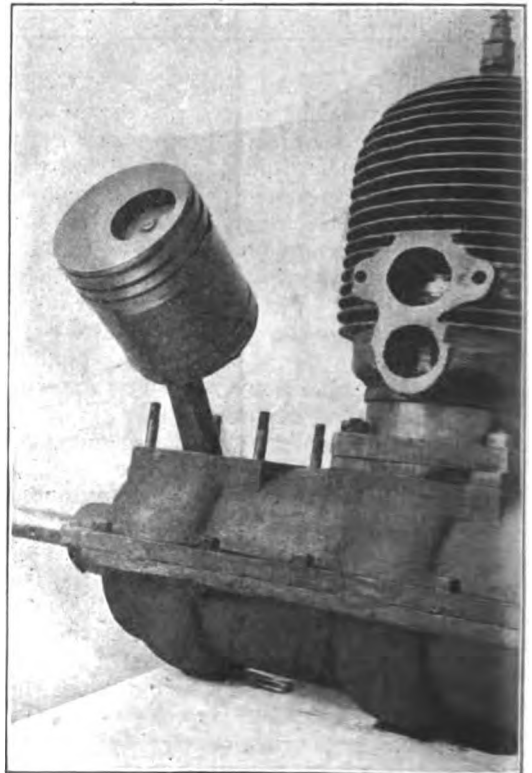

$4\frac{1}{4} \times 4\frac{1}{4}$ Four Cylinder, Two Cycle, Air Cooled Engine

of consumption, and, while it is true that this company has many sources of supply and many avenues of delivery, yet there was an insurmountable barrier, in the minds of the railroad people, as to the advisability of purchasing current at any price, if the convenience of the patrons was to be sacrificed in any way. As one of the officers of the railroad company remarked: "We certainly desire to save money in the operation of our property, within reason, but at the same time we care more for the good will and satisfaction of our patrons, and if any interruption of service should occur on all your lines feeding into the city at one time, we can not expect our citizens to be patient while sitting in the cars for one and one-half hour until you get up steam."

The railroads are operating their steam plant for this service, and the power company suggested the continuance of the operation of these steam plants, and receive a portion of the power from the power company, but this plan was not considered advisable. After numerous interviews, with an honest desire on both sides to try to accomplish the economic result, if it could be done without sacrificing the interests of the patrons of the railroad company, a firm conclusion was reached that in a service so large and important as the carrying of hundreds of thousands of people daily in a large city, nothing could be done on the plans outlined unless some absolute guarantee of continuity of service were available, and it certainly was not favorable from the standpoint of the utilization of steam engines for emergency purposes, because if steam were being maintained constantly under the boilers, no economy would result, and if the plants were allowed to cool off the time element of starting would prohibit their use.

The officers of the power company had been making thorough investigations of the development of the gas engine in large units, having sent two of their engineers throughout the entire East to make full and complete reports. In consequence, and as a last resort, the power company agreed to install three gas engine electric generating units, each unit having a capacity of 4,000 k.w., or a total initial capacity of 12,000 k.w. This plant will be enlarged as rapidly as the requirements of the railroad may demand.

The guarantees which have been made by the manufacturers of these engines are particularly interesting. They place electric transmission in a position to practically guarantee continuous service, regardless of the length of its transmission lines or the momentary interruptions which occur through causes beyond human control. It might be fairly stated that the gas engine stands alone as the only means of instantaneous generation of electric current at distributing centers in times of emergency at any fair or reasonable cost.

The gas engine electric generating plant of the California Gas and Electric Corporation will also be utilized to a certain extent for the purpose of increasing the load factor of the transmission line, for it is obvious to those familiar with power transmission plants that after proper installations have been made, including full capacity at the hydraulic end, as well as in the power house, and in pole lines, there is absolutely no increased cost for current to the power company, whether its load factor be 0.2 or 0.99, and any device which can be utilized to improve the load factor adds that much income and net profit for the power plant. In this particular case the gas engine generating plant was a necessity, for without it the California Gas and Electric Corporation would have been unable to have obtained the contract for power. That being the case, the officers decided to make a virtue out of this necessity, and up to the extent of the cost of fuel being less than the increased value derived from improving the load factor on the power lines, they propose to operate this gas engine plant in that manner and for that purpose.

The gas which will be used to drive these engines will be manufactured from crude oil, and will be of the quality similar to the illuminating gas now being distributed throughout the State of California manufactured by this process, ranging from 610 to 660 B. T. U. per cubic foot.

Nearly all of the gas engines in use throughout the East and Europe are utilizing producer gas or blast furnace gases, except in very small units or where natural gas can be obtained, and from investigations which I have made I have ascertained that the largest engine using manufactured gas of more than 600 B. T. U. has a rated capacity of 300 H. P., while those in pro-

cess of installation near San Francisco will in each case be more than seventeen times as large. The nearest approach to these large engines in size are two which are in operation at Hastings, W. Va., each having 4,500 H. P. capacity and driven by natural gas. They are used for the compression of natural gas for transmission through a pipe line 200 miles in length. These engines have been and can be started from cold and rest to full load in less than 60 seconds.

These gas engines are now being built by the Snow Steam Pump Works, of Buffalo, N. Y., and in general design and detail resemble very closely a modern high-grade, massive American steam power engine. They are of the horizontal, twin-tandem, double-acting, four-cycle type, giving two impulses to each crank per revolution. This is equivalent to a cross compound steam engine. Any cylinder head can be removed from any cylinder by simply disconnecting one jacket water supply pipe and removing the nuts holding the head to the cylinder. All working parts are above the engine room floor; nothing but water supply, gas, air inlet and exhaust pipes are below the floor, and these are arranged so that they can be trenched. All the main parts have their proper relative positions positively and permanently fixed by male and female entering fits of large diameter, thus practically insuring self-alignment.

Lubrication of the cylinders is effected by spreading. This is accomplished by leading four oil feeds, fed by individual oil pumps, to each cylinder, and entering the cylinder at points to effect successfully the proper spreading of the oil. The oil is fed to the cylinder on the inhalation stroke, thus being properly lubricated for the power or impulse stroke. The lubrication of journals is effected by means of a positive feed lubricator. Each oil feed is carried to the part to be lubricated by means of small tubing leading from a multiple feed oiler containing a small oil pump for each feed led therefrom. The feed to each part is positive and can be adjusted to give a fixed supply of oil per revolution of the engine. When the engine stops the oil feed stops, and when the engine starts the oil feed also starts. Inlet valves, mixers and cut-off valves will be designed so that gaso-

line can be injected to the surfaces to be cleaned, rendering the dislodgment of any deposit an easy matter without removing the parts.

The pistons are carried by cross heads, thereby materially reducing the weight carried on the bore of the cylinders. By the use of three cross heads, the main, intermediate and outboard, the proper alignment of the pistons is permissible after years of service, and it is questionable whether an engine without this feature can be regarded as entirely satisfactory.

The question of regulation in the generation of electric current by means of direct-connected generators (of Crocker-Wheeler make in this case) has been a problem not only for the gas engine people, but for the steam engine manufacturers to solve and this has been done in the latter case within the past two years practically to the satisfaction of the electrical engineer, so that parallel operation is now successful. The builders of this engine are also following steam practice in this respect, and will be able to keep the angular variation within each revolution at a minimum, satisfactory to the generator manufacturers.

The main shaft will be of the overhung crank type, having the cranks forged with the shaft and with crank pins forced into the cranks. The main connecting rods are simple, plain, with solid adjustable stub ends. The main cross heads are fitted with adjustable babbitted gibs and removable crucible steel wrist pins.

The pistons are designed in such a way that expansion of the faces can take place without affecting in any way the strength or life of the piston. Piston rods extend from the main cross heads clear through the cylinders to the outboard cross heads, to which they are secured by nuts. Each cylinder is made in two parts, the joint being circumferential and located half way between the ends.

Separate supply pipes for each individual part to be water jacketed will be furnished, so that the amount of water fed to each part can be regulated, thus permitting the carrying of high temperatures in such parts as cylinder heads, medium temperatures in cylinder jackets, low temperatures to the rods, pistons and metallic packing.

These engines are started by the use of compressed air on storage in compression

tanks. Safety devices are provided which carefully control the speed limit.

The dimensions of these engines are very interesting: Length over all, 70 feet; width over all, 34 feet; weight of heaviest casting, 60 tons; diameters of cylinders, 42 inches; length of stroke, 60 inches; main journals, 30 inches in diameter, 54 inches long; main cross head gibs, 27 inches wide, 54 inches

long; diameter of center of shaft, 38 inches; weight of fly wheel, 130,000 pounds; total weight of engine, fly wheel and generator, 1,200,000 pounds.

These engines will probably be in operation on or before January, 1906, and from all the investigations which have been made by my co-workers, we are laboring under no doubt as to the absolute success of this installation when completed.

POWER FOR LIGHT MANUFACTURING FROM SUCTION PRODUCER GAS.

As the winter season comes near, the stove, neglected for the summer of all men and of all women except when household musts make need, again becomes the center of attraction to the household, and is tended and paid homage like a prince.

Most of us get down the old stove from the attic, or arouse it from its drowsy and frowzy rest in the corner, give it a fresh coat of graphite and elbow grease, and hurry it, on a cold morning into the busy work of the world again. Some, however, by reason of building a new nest, by failure of the faithful servant which has earned repose in the junk heap (until the foundry gets it again) or because of added spare shekels which must be spent for something — (did anybody say, "Who's got 'em?") — are investing in a new altar on or rather in which to offer up to the power of Boreas our tribute of black diamonds.

Where do the new stoves come from? Well! we suppose from lots of places; but, after going through the storehouse of the Cole Manufacturing Company, at Thirty-second Street and Western Avenue, Chicago, where 50,000 stoves are stored as the result of the summer season's work, where a stove a minute is turned out all day and whence 2,000 stoves are shipped daily in the busy season, it seemed as if stoves mostly came from that factory. At any rate, Cole's Hot-Blast stoves will certainly make lots of homes happy when the supply which was stored even up into the rafters all get to doing their proper work.

For such manufacturing, the power needed is comparatively light, but must be distributed over a wide area and light shafting with belts and pulleys has been

found the most available means, some 1,000 feet of shafting being in use. For motive power, it was decided to use an Otto suction gas producer plant and engine, and the decision has proved to be most satisfactory. This plant is located in a separate building, just outside of which is located the underground reservoirs for cooling water. The outfit is rated at 60 H. P., and runs at between 20 and 30, using from 450 to 500 pounds of anthracite pea coal in a ten-hour day. This is put in four charges which, with cleaning out ash in the morning, an occasional stirring to keep the draft clear, oiling the engine and keeping the water supply to the producer at the proper amount, is all the attention needed. The fuel cost is some 75 cents a day.

Three principal vessels make up the producer plant, the generator, the producer proper and the scrubber. The producer is a plate iron vessel 4 feet 6 inches in greatest diameter by 7 feet high, with a 6-inch lining of fir brick. The grate is at the bottom of the producer and fuel is put into a hopper on top so that the action is much like that of a base burner stove.

Beneath the grate, a mixture of air and of steam from the generator is introduced, the proportions of the mixture being important. From above the fire the hot gases are led to the generator, which is much like a feed-water heater, the hot gases passing around the tubes, down one side and up the other, and then on to the scrubber.

This is a cylinder filled with coke over which a spray of water falls, thus washing all dust and tarry products from the gas as it passes upward through the scrubber from the top of which it is taken to the

reservoir to be drawn thence by the engine.

By the use of air saturated with steam for burning the fuel, a large amount of hydrogen is given to the gas, which increases its heat value so that it is about 135 B. T. U. per cubic foot.

In starting the engine, which has a cylinder 14 x 16 inches and runs at 210 r. p. m., compressed air at 100 pounds pressure is used. This is taken from a storage tank to which it is pumped by a belted compressor driven by a 2 H. P. engine using city gas and which serves to drive the blower fan used in starting up the fire. After about 15 minutes, the gas, as tested at a try cock, will burn with a rich blue flame and the main engine is then started, the blower shut off, and air and steam from the generator turned on to the producer.

When shutting down at night, the air and steam supply are shut off, an air vent opened to give enough draft to hold the fire, and the generator drained of water. Before the main engine is ready to start, the lean gas from the producer is carried through the roof by an outboard exhaust which rises from a tee in the pipe leading to the scrubber.

Construction and operation of the Otto engine were fully described in the issue of January 1, 1905, the only special feature of this plant being the method of supplying cooling water to the jacket.

Rain water from the roofs is collected in an underground reservoir and from that is taken by a centrifugal pump belted to the side shaft of the engine. From the jacket the water flows to a set of perforated, inclined zinc trays down which it runs, reaching the reservoir cooled and ready for another round.

John Coleman, the engineer in charge of the plant, states that it has given no trouble in the two months of operation and that he is glad he posted himself on producers so that he was ready for the opportunity when it came. He has devised a special charging apparatus which holds the right amount for a charge.

Tests have been made on the plant by Prof. H. B. MacFarland, Armour Institute of Technology, to determine the power produced and the distribution of the power.

The back pressure upon the engine due to the drawing of the gas through the generator, vaporizer, scrubber and necessary pipe connections was slight, being only $2\frac{1}{2}$ inches of water at the engine. Suction on the entering side of the scrubber was $2\frac{1}{8}$ inches of water, so that only pressure equivalent to $\frac{3}{8}$ inch of water was lost in drawing the gas through the scrubber and the connections from it to the engine. The suction at the foot of the 3-inch pipe which conducts air into the vaporizer was $\frac{1}{2}$ inch of water. The suction necessary to draw the gas through the fuel bed, vaporizer and pipe connections was $1\frac{5}{8}$ inch of water.

City water was used in the scrubber in order to cool the gases and wash them free from fine particles of dust. On an average 1,800 gallons of water was used daily for scrubbing purposes, which, at 9 cents per thousand gallons, makes the daily cost for water 16 cents.

In the vaporizer, the temperature of the water varied from 170 to 190 degrees, while that of the air and steam therein was from 165 to 170 degrees. The temperature of the water in the bottom of the generator was 150 degrees and it may be assumed that the air was saturated at this temperature when it entered the fuel bed.

In order to determine the horse-power developed by the engine, that used for doing work and that absorbed in running the shafting, belting, etc., a Prony brake was applied to one line of shafting. For an engine of this type with a hit-and-miss method of governing, the horse-power developed by the engine above half load is very nearly, if not exactly, proportional to the number of explosions. Upon this assumption, the horse-power absorbed by the shafting was determined. The maximum brake load for a very short period of time was 45 H. P. The mean load for 1 hour was 42 H. P. plus that required to run the shafting.

The horse-power absorbed by the shafting was 19 H. P. A record of the number of explosions of the engine was made regularly during the day for a period of two weeks. The average number of explosions was 42.5 per minute; the maximum was 45 and the minimum 39.

42.5 explosions per minute means that the engine is developing 27 H. P., of

which 19 is absorbed by the shafting and 8 in doing useful work.

A daily record of the coal consumption is kept by the engineer, and from this a fairly accurate estimate of the coal consumption per developed horse-power per hour was made.

This shows that 1.6 pounds of coal per developed horse-power per hour was used for half load of the engine, standby losses included.

The coal used is fine anthracite screenings, costing \$3.50 a ton delivered. It had a heating value of 13,500 B. T. U. and analyzed as follows:

Moisture	3.03 per cent
Volatile matter	1.03 per cent
Ash	6.38 per cent
Fixed carbon	89.66 per cent

Total

100.00 per cent
(The gasoline for the engine which formerly ran this plant cost \$3.50 a day.)

The generator is filled and the grates cleaned five times a day. The ash is removed every morning. The area of the grate is 31.7 square feet, so that at present about 13 pounds of coal are burned per square foot of grate surface per hour.
—*The Engineer.*

THE GASOLINE ENGINE ON THE FARM.

In these days of changed agricultural conditions, power of some kind for operating the many different machines of the modern farmer has become a necessity. Farm help is getting scarcer each year, and the farmer must depend on some more reliable, efficient and economical method of doing much of his work. A great deal of a farmer's time, especially in the winter, is occupied in "doing the chores" about the barns. This not only consists in feeding and watering the stock, etc., but there is much work to do in preparing the feed, running the feed cutters and grinders, corn shellers, fanning mills, pumping water and many other jobs too numerous to mention. A large portion of this work can be done by power, thus saving much of the farmer's time and the expense of one or more hired men. The farmer is beginning to realize that it is no longer a question of how many acres he can farm, but rather how much can he produce from one acre? Anything that will help in increasing the productiveness of his farm, and at the same time reduce the cost, is a decided advantage, and should be quickly employed by the progressive farmer. Plenty of water at all times is essential to the successful modern farmer and dairyman. It is almost impossible to have plenty of water without some kind of power, and none has proved so satisfactory to the farmer as the gasoline engine. It furnishes ideal power for pumping water, sawing wood, and for operating the various machines in the stock barns and the dairy room. A small gas or gasoline

engine will pump enough water into an elevated tank of sufficient capacity to last all day, and do it while the farmer is eating his breakfast. While for sawing wood of the proper length for the stove there is nothing so efficient. What a pleasure it would be for the farmboy to furnish the necessary supply of wood with an engine and circular saw. It is safe to say that the wood pile would assume stupendous proportions, instead of its usual condition of hardly enough wood to start a fire. It is no wonder the farmer's son longs for a different job. It is natural for most boys to desire to use machines that will assist them in their work. Much of the time spent with a buck-saw might, by using power furnished by a gasoline engine, be saved.

A good, reliable gasoline engine will save its cost in grinding feed for the stock.

The farmers throughout the Eastern States, where their farms consist of from ten to fifty or one hundred acres, are fast learning that it is more profitable to cut all the dry feed, such as hay, straw and fodder, than to feed it whole. It has a much better feed value, and lasts much longer, because it is practically all eaten, while the small amount that is refused is very much preferred as bedding because it is a good absorbent; it is also easier to handle and makes better manure. Here the gasoline engine again comes in as a most profitable investment. In one half day each week it will cut enough fodder to feed all the stock the remainder of the week, unless one is

making a business of feeding large herds. The feeders of large herds of cattle have learned the economy that results from grinding their feed and cutting their fodder before feeding to their stock. They have their own power and by reason of its convenience is always being ready to start, and because it needs practically no attention when it is started, the gasoline engine is the most desirable type of engine for the farmer. Then, again, it is well understood by many farmers that a little shop on the farm for the purpose of repairing imple-

ments and sharpening tools is profitable, as it saves both time and expense. The little engine is used to drive the grindstone, emery wheel, band-saw, drill press, blower for a small blacksmith forge, etc. There is also the cream separator, the churn, and the bone-cutter, which is a real necessity where poultry profits are considered. All these machines can be operated by a gasoline engine and made to yield a great profit, saving an endless amount of drudgery and converting the work into a pleasant task.—*Deering's Farm Journal*.

TWO GAS ENGINE ACCIDENTS.

Two interesting accidents to gas engines are described in the report for 1904 of Mr. Michael Longridge, chief engineer of the British Engine, Boiler and Electrical Insurance Co., of Manchester. The first accident happened to an engine with an 18-in. cylinder, 24-in. stroke, and speed of 130 r.p.m. It was running on town gas and was nine years old. The shaft, which had four bearings and two fly-wheels, broke through the crank pin. The pin was 6½-in. diameter by 8-in. long, the bearings on each side of the crank were 6½-in. diameter and 12-in. long, and the distance between their centers 35 in. The initial pressure on the piston was 350 lbs. per square inch, of which about 40 lbs. per square inch would be required to impart velocity to the moving parts, leaving about 310 lbs. per square inch of piston area, or 79,000 lbs. as the load upon the crank pin at the beginning of the stroke.

Taking the shaft as a beam 6½-in. diameter and 35 in. long, loaded in the middle with 79,000 lbs., the stress at the middle of the pin will be 25,000 lbs. per square inch; while if the length of the beam will be assumed to be only 23 in., the distance between the inner ends of the bearings, the stress will be 16,500 lbs. per square inch. And besides this, the pin at the beginning of the stroke had to bear a part of the stress exerted by the fly-wheel on the side of the crank remote from the belt driven, for this wheel is then driving part of the load.

The stresses on the shafts of gas engines are not easily amenable to calcula-

tion, Mr. Longridge points out, especially where there are more than two bearings; but even when there are only two the calculations are laborious, and generally imperfect, owing to lack of data. For the stresses are modified by the tension of the driving belt, generally an unknown quantity, and the direction of its pull being greater when the driven drum is behind than when it is in front of the cylinder. They are also modified by the number of fly-wheels, being less with two than with one, and by the position of the heavier sides of the wheels relatively to the cranks if the wheels be out of balance, weights opposite the cranks increasing the stresses on the crank pins.

The second accident happened to a single-cylinder engine, six years old, supplied with Dowson gas; cylinders 11½-in. diameter, by 18-in. stroke; speed, 180 r.p.m. The big end of the connecting rod was of the marine type, with a cap secured by two ¾-in. steel bolts screwed with Whitworth threads, nuts and lock-nuts. One of these bolts broke at the root of the screw thread. The cap was torn off, the other bolt and the rod were bent, and the piston, cylinder liner and bed-plate broken. The cause of the breakage was probably repeated blows owing to slackness of the big end brasses, for the inspector in whose district the engine was frequently complained about it.

During the explosion and compression strokes there is no stress on the connecting rod bolts of a single-acting gas engine, as the rod is in compression, but at

the end of the exhaust stroke the force required to arrest the piston and connecting rod is furnished by the fly-wheel, and so the rod and its bolts are in tension. Also, at the beginning of the admission or suction stroke the force required to overcome the inertia of the moving parts and start them in their outward course, as well as power required to produce the partial vacuum in the cylinder, is furnished by the fly-wheel, and transmitted by the bolts in tension.

In the case of the engine just referred to these forces probably put a load of about 6,000 lbs. upon the two bolts, causing a tensile stress of 7,100 lbs. per square inch upon the cores of the screw threads. It is not surprising to Mr. Longridge that a screw thread exposed to many sudden repetitions of such a stress should break. But it is not only to tensile stresses that the connecting-rod bolts of some gas engines are exposed. They have sometimes to resist bending stresses also, which are much more fatal to pieces with abrupt changes of sectional area or screw threads than merely direct pulls.

Sometimes the brasses of the big ends of gas engine connecting rods are planed across the backs which fit against the butt ends of the rods and caps. They are not counter-checked into the butts or caps or into each other, but are kept in alignment only by the bolts and crank pin, or if they are slack upon the crank pin, only by the bolts. The bolts in the case of a horizontal engine lie approximately horizontally. The big end of the connecting rod moves up and down as well as to and fro. The force that moves it up and down is transmitted from a crank pin to the brasses, from the brasses through the bolts to the butt end and cap. This force is approximately at right angles to the axis of the bolts, and therefore exerts either a shearing or a bending stress upon them, depending on the fitting of the parts. Having regard to the number of breakages of connecting-rod bolts it is suggested that 7,000 lbs. per square inch, which seems to be about the usual stress allotted to them, is too high. —*The Engineering Record.*

A S C O T C H F I S H I N G S C H O O N E R

In our August issue we commented on the recommendations of a British officer relative to employing power boats for fishing service in the Scotch fisheries. It will be recalled that the officer declared that any gasoline engine was useless in such service, and recommended the use of boats equipped with engines using kerosene or heavier oils.

A recent issue of *The Motor Boat* gives the following information regarding a government fishing schooner which has been equipped with a 25 H. P. Dan kerosene engine to demonstrate to the Scotch fishermen the advantages of this type of power for fishing vessels.

The *Pioneer* is a big boat, of the Scotch lugger type, 72 feet in length, 21 feet beam and 8 feet draft aft. She carries a large amount of sail on two masts, and can make 11 knots under sail alone in a stiff breeze.

The motor of *Pioneer* is a 25 H. P. Dan, made by P. Jorgensen, at Copenhagen. It is a slow-running, heavy type of engine,

weighing about 2½ tons. Its dimensions are as follows: Length, from forward side of fly wheel to after end of clutch, 5 feet 10 inches; height, from bottom of fly wheel to top of exhaust box, 7 feet 8 inches; from base plate to top of vaporizer cover, 4 feet 6 inches; the diameter of the fly wheel is 40 inches, and of the clutch 35 inches. These figures show that the motor is built for hard usage.

The cylinders are 10½-inch bore and 13-inch stroke, with water-cooled bodies, but unjacketed heads, for the vaporizer, which has to be red hot, is fastened in the head. First of all, the best idea of the shape of the Dan vaporizer may be gathered from its resemblance to a jam pot, but with a somewhat narrower and longer neck. This is inverted, and the neck fastened into the cylinder head. Into the wall of the vaporizer passes the fuel inlet pipe, which is water-cooled just at that spot. The kerosene is pumped up a tube to the inlet pipe, the delivery being made during the compression

stroke of the engine, and, owing to the water-cooling on the inlet, the kerosene always passes into the bottle vaporizer at a very low temperature. On entry, it is immediately vaporized, and on the up stroke of the piston a portion of the air in the cylinder passes into the vaporizer, where it forms an explosive mixture. Owing to the high temperature in the vaporizer, the mixture spontaneously explodes when a certain compression is reached and the cycle recommences.

Of course, to start up, the vaporizer must be heated by "Swedish" lamps, but when the engine is running the high temperature of the explosion keeps it red hot, and that is the reason why the cylinder heads are not water-cooled. There is a check valve on the inlet valve to prevent any back-fire into the fuel delivery pipe. It appears thus that the explanation of the steady running of the engine lies in the fact that the kerosene is not vaporized until it is required, and that, after being vaporized, it has no pipes, bends, ledges or corners on which to recondense. There is no air mixed with it until the explosion is almost taking place, and, therefore, the kerosene vapor, being homogeneous, is much more perfectly vaporized—this is borne out by the smokeless exhaust from the engine. The principle is substantially the same as that of the Hornsby-Akroyd engine, but in the Dan the idea of cooling the fuel so that it always enters the vaporizer at nearly as possible the same temperature is a great improvement.

Just forward of the clutch is a centrifugal governor, mounted on a shaft driven off the crank shaft at half the speed of the engine through a worm gear. Off the same shaft are driven two oil plunger pumps, one on either side; the governor controls the supply from each of these pumps to the particular cylinder served, a hand control also being provided. As the kerosene has to be pumped up about $4\frac{1}{2}$ feet of copper tube, a check valve is placed in the pipe just above the pump in order to prevent draining back.

The automatic air inlet valve is situated right over the exhaust valve in a water-cooled chest on the cylinder. The water cooling of the valves is very thorough; in fact, they are cooled all around. During the eleven years that Herr Jorgensen has been building motors, he has never yet been

obliged to change any valves on account of burning or pitting. The exhaust valve on each cylinder is driven off a half-speed shaft, actuated from the crankshaft through a worm gear. A second cam can be brought into action on the half-speed shaft, in order to relieve the compression when starting up. From this same shaft the water pump is driven, through a belt, which runs another shaft actuating the plunger, and off the crank shaft at the forward end.

The circulating water passes first around the cylinders, then around the valves—with a branch to keep the fuel inlet cool—and out through the jacket of the silencer above the engine. With the exception of the links between the piston and crank shaft, there are no other moving parts about the engine. One important detail remains, viz., the lubrication, which is effected by syphon feed to every bearing from a central distributing box, divided up radially.

The simplicity of this engine is its most characteristic feature. There is, practically speaking, only the engine body, piston, connecting rod, crank shaft, valves and half-speed shafts, oil and water pumps and governor. The vaporizer can not fail, for it must remain hot, once the engine has started, and hence the latter runs until the oil supply is cut off. The absence of electric ignition of any kind is a great advantage in a marine motor which will be placed in charge of fishermen.

The cost of this motor, complete with shaft and reversible propeller, was only \$1,800, with another \$150 added for installation, which is very cheap, for the Dan motors run for years without a single repair, and they are stout enough to wear as long as the ship lasts, which means a long lifetime. The running costs are low, the consumption at full power being about 10 or 11 pints per hour, to which must be added the cost of lubricating oil, which is a variable expense and difficult to apporportion without data.

A reversible propeller, with blades capable of being set for ahead or astern, and a fore and aft feather for sailing, is worked from the deck, just near the steering wheel, the position of the blades being indicated by a pointer on a straight scale. The motion is transmitted to the reversing rod in the hollow tail shaft by means of a chain and worm gear.

ANSWERS TO INQUIRIES

It is our purpose to answer in this column inquiries of general interest which relate to the gas engine or its accessories. The questions will be answered in these columns only, and we reserve the privilege of refusing to answer any question which is not, in our judgment, of interest to the subscribers of THE GAS ENGINE.

All matter intended for this department should be addressed to The Editor of THE GAS ENGINE, Blymyer Building, Cincinnati, Ohio. The name and address of the sender must accompany the inquiry in all cases as evidence of good faith. The initials only of the sender will be published, together with the postoffice and state.

Write on one side of the paper only, and make all sketches and drawings on a separate sheet. Mark each sheet with the name and the address of the sender.

(a) Referring to page 32 of Haenssger's Suction Gas, about what is the difference in level of the water in the pressure gauge glasses for the different parts of the system? (b) What thickness of sheet metal is used in making the scrubber, generator, etc.? I suppose it varies with the diameter of the shell.—J. W. C., Kansas.

(a) The glasses referred to are largely for comparative use. Of course, when the plant is at rest the heights should be the same in all cases, as there is no suction or pressure in the system. If any one passage becomes considerably clogged up, the gases can not flow through as rapidly as they should when the suction is effected, and the gauge glasses behind this passage will show a slower action than the glasses ahead of it. The difference in any one plant would depend on its construction.

(b) The thickness of the shells varies not only with the diameter, etc., but also with the manufacturers, just as does the amount of jacket space vary with engine builders. Some of these generators, etc., are made with cast iron, in which case the thickness is much greater.

(a). How much more power has a two-cycle engine, 4 x 4-inch cylinder, than a four-cycle engine with a 4 x 4-inch cylinder, both run at the same speed? (b). Are all two-cycle engines subject to

crankcase explosions, and are they liable to damage the engine in any way?—J. W., Gibson, Iowa.

(a). About one-third to one-half more power. (b). Yes, more or less, according to design of engine. They are harmless, provided the crankcase is thick enough.

I am building an engine, four-cycle marine, with opposed cylinders, 5½ x 5-inch stroke. What horse-power should it develop at 400 revolutions, and what at 600?—F. A. R., Digby, N. S.

8 H. P. at 400 r. p. m., 12 H. P. at 600 r. p. m.

What will be the proper place and size for crankcase port for a two-cycle marine gasoline engine, cylinder 3¾ inches, bore 3½ inches, stroke 600 r. p. m.? (b). The flywheel is 13¾ inch diameter, weight 75 pounds, rim 3 x 3 inches. Do you think this is right?—C. B., Philadelphia, Pa.

(a). The crankcase port should be 1½ x 5⁄8 inch, the smaller dimension in the direction of piston travel. Make the top of port and bottom of piston even when piston is at top of stroke. (b). Yes, about right.

(a). What is the action of a jump-spark coil with and without an interrupter? (b). When is a coil without an interrupter used?—A. H., Wheeling, West Virginia.

(a). A coil with an interrupter gives a series of sparks at the plug; that without an interrupter gives but one spark when contact is broken at the timer. (b). Non-vibrator coils are used almost exclusively for motor-cycles.

Please inform us in your next issue the meaning of a "three-port engine."—J. E. B., Seattle, Wash.

The "three-port" two-cycle engine is one in which the mixture enters the crankcase through a port opened and closed by the piston. This gives it three ports. The usual type draws the mixture into the crankcase through a check valve and is called a "two-port" engine.

(a). Will vapor of kerosene mixed with hot air in equal quantities remain in gaseous state indefinitely? (b). What sized cube of gasoline (liquid state) for same size cylinder? (c). What are gasoline engines self-starting not more successful or more used?—D. A. B., Ewart, Michigan.

(a). No; air will not hold more than about 27 per cent at 68 degrees F. kerosene vapor. (b). 0.65 cu. in. vapor. .006 cu. in. liquid. (c). There are quite

a number of so-called "self-starting" gasoline engines, many of which are very successful.

(a). What is the quickest and easiest way to remove asbestos and red lead from cylinder joints when the cylinder head or exhaust chamber has been taken off to be repacked?—A. K., Alpena, S. D.

(a). The only good way we know of is to use a scraper, being careful not to gouge the faces of the joints.

SOME CANADIAN IMPORT FIGURES.

Gasoline engines imported into Canada are subject to a general tariff of 35 per cent, unless they come from Great Britain, in which event they are subject to a rebate of 33 1-3 per cent, as there is a preferential tariff with the mother country. During the fiscal year ending June 30, 1904, Canada imported from Great Britain engines to the value of \$1,413, while from the United States the gasoline engine imports were valued at \$126,353. Engines to the value of \$85 were imported from other countries, so that the total value of imported engines was \$127,851.

During the fiscal year ending June 30, 1905, there was imported from Great Britain but \$403 worth of engines, while from the United States the value was \$193,547, and there were \$124 worth from other countries. The total value for 1905 was \$194,074.

This means that while the total imports during 1905 showed an increase of \$65,606

(over 51 per cent), Great Britain's share of imports decreased during the year to less than a third of her share during 1904. In the other hand, the imports from this country increased \$67,194 in amount, an increase in percentage of over 53 per cent. While the total value of imports from other countries is small, yet these showed an increase during the latter period of over 45 per cent as compared with the earlier year.

During the same periods the imports of automobiles from Great Britain amounted to \$2,403 and \$6,605, respectively; from the United States they amounted to \$312,854 and \$395,043, respectively. The total imports from all sources during these two years were \$315,475 and \$453,904, respectively. Great Britain showed an increase of nearly 175 per cent, while the United States showed an increase of but slightly over 26 per cent. The general tariff on automobiles is 25 per cent, while Great Britain enjoys the rebate of 33 1-3 per cent.

THE GASOLINE ENGINE IN THE DAIRY

Very few people realize how generally gasoline engines are coming into use on the up-to-date farm, especially on dairy farms. A few years ago good dairymen thought that steam was the best dairy power, because it could be used for cleaning pans and cars. The use of the cream separator seems to have changed that, for now on many farms the milk is poured from the milk pails right into the separator. The cream cars are taken from the farm and steamed at the creamery, leaving only the milk pails and the separator to be cleaned

at home. This has driven the steam engine from such farms on account of the gasoline engine occupying less space, costing less to operate, and giving the needed power. The gasoline engine has been perfected, so that it is now thoroughly reliable and furnishes ideal power, not only for the farm dairy, but for operating wood-saws, feed cutters and grinders, huskers and shredders, and for general purposes where a practical, economical power is required.—*Deering's Farm Journal*.

APPLICATION OF GAS POWER TO ELECTRIC RAILWAY SERVICE

The possibility of using gas power in electric railway service is now well established by a number of such plants, but it is important in considering any such installation to bear in mind the characteristic demands of power for such work, and their difference from the demands of electric lighting. This point was well brought out in the opening portion of a paper read before the American Street Railway Association the last of September by Mr. J. R. Bibbins. He pointed out that a generating plant for railway service, especially for suburban and heavy duty work, must be unusually responsive to sudden power demands; to accomplish this the two sections of the plant must be peculiarly well fitted to operate together under normal load conditions. The plant should also be quick in starting, capable of standby for long periods without excessive loss of heat, and, above all, should show high all-day fuel economy. The adaptability of the gas engine to this service must be granted, and the discussion of gas power for railway service will hinge on other features of the plant.

The future of the gas engine in its general application depends largely upon the development of a producer gas system especially suited to the use of low-grade bituminous coal. Anthracite producers have already reached a high state of perfection, are reasonable in price, simple to operate and are usually unencumbered with much auxiliary apparatus. They do not deteriorate rapidly, and generally show an efficiency considerably higher than the best steam boiler and furnace, viz., 75 to 80 per cent.

The ideal bituminous producer is yet to come, viz., one in which the volatiles are completely converted into fixed gases without serious loss and without complication of the operating system. There are a number of makes now on the market intended to be used with bituminous coal, but when the gas is to be used in engines they are attended with special, and often complex, cleaning apparatus for the removal of suspended impurities. The efficiency of bituminous systems is also generally lower than anthracite, not only owing to the fact that some of the valuable distillates are lost, but on account of the distillation of volatile

matter requiring heat for its accomplishment. Present types sometimes exceed 70 per cent efficiency, which rivals that of the best boiler plant.

Passing to some of the practical points, a producer, if provided with an automatic blast control, may be made almost instantly responsive to variations in demand for gas. This is shown by the success which the suction producer has attained in small sizes; and in this respect the steam boiler is quite outclassed, owing to the more direct effect of the blast in transferring the heat contents of the coal to the working medium—gas. In one type of producer the steam blast and consequently the gases generated are controlled entirely by the pressure in the delivery gas main and in inverse proportion. Steam is generated at a rate proportional to the demand for gas, without requiring extra boiler equipment or fuel. This largely increases the producer efficiency.

This producer is designed for use without a gas holder, and has been successful in this particular. The especially severe conditions of heavy railway work, however, prescribe storage capacity at some part of the system. Owing to the limitations of gas engine capacity, electric storage is evidently the most desirable, as it relieves the machinery of the wear and tear of fluctuating loads. There is ample precedent the world over for the use of a storage battery auxiliary in railway plants, and it should prove even more desirable in a gas power than in a steam power plant. In fact, gas storage is often to be desired in many plants where the gas demand varies greatly, simply as an insurance against poor gas, due to careless operator. This, however, simply relieves the gas generating equipment, while electric storage relieves the entire station.

Stand-by losses in a steam power plant are an important source of inefficiency, and difficult to determine accurately. Mr. Dowson has made some comparative observations with eight steam plants and several producer plants, averaging about 250 H. P. capacity. The actual stand-by fuel consumption of the boilers was 35 to 180 lbs. per hour, and of the producers 2 to 4 lbs. per hour. Running losses are evidently

also much less. We may pipe gas for great distances with small loss. Not so with highly superheated steam under high pressure. When a gas engine plant is shut down the losses practically cease; with steam, condensation is uninterrupted.

The comparative cost of labor and supplies for gas and steam plants is difficult to state in definite terms. With the same character of labor there should be no appreciable difference between the two. A very important point is the personal attitude which engineers take toward gas machinery. The best plant will quickly depreciate in the hands of operators who have taken a personal dislike to the innovation. In many plants the old steam engineers and oilers have been retained and placed in charge of gas equipment, after a thorough coaching by competent erecting engineers. After this is done properly the invariable result is highly successful operation.

In well-regulated plants, equipped with a continuous return system, the oil consumption should not much exceed, if any, that of a steam plant. Two 500-k. w. gas plants at Franklin and Bradford, Pa. (each consisting of five vertical enclosed type engine units), average through the year less than half a gallon per unit day. At another station, near Warren, Pa., using three vertical open type engines of 275 H. P. capacity each, the oil consumption averages under 0.9 gallon per unit day.

Maintenance expense is frequently thought to be excessive in a gas station. When this is so we may look for faulty operation or design of the plant. Recent data from the station at Bradford, Pa., shows what may be accomplished when the equipment is properly operated. The plant is in its seventh year of service, yet the average cost of repairs on the engines for the last two years was \$92.70 per year, or 11.6 cents per H. P. year. After six years' service, averaging 18 hours per day, it was found necessary to inspect the engines only once in twelve months. This was formerly done in three months, and later in six months. At each inspection a set of piston rings is replaced by new ones, whether worn out or not. Up to the present time no extensive repairs have been made on any of the engines, except a voluntary change, on the builder's part, from dry to water-cooled exhaust valves. The present exhaust valves

average one year's working without re-grinding, and even these are not in bad condition. Some valves have run 15 months. Admission valves require no attention. Igniters average about nine months without repointing. By reversing the current each day electro deposition is entirely avoided, so that the points wear evenly.

A notable run was recently reported by the superintendent of a gas compressing station in central Ohio, where a 650 H. P. vertical engine is at work. This engine was under maximum gas load continuously night and day for 40 days, without a misfire or mishap of any kind, and without incurring extra expense for repairs.

Much of the prejudice against gas power is due to exaggerated statements regarding the comparative capital cost of steam and gas equipments. In some instances it has been stated that for the same character of equipment the gas plant costs double. This is not the case; in fact, in larger plants the two may be brought nearly to a parity, and the higher economy of the former will soon wipe out the difference in actual cost.

The engineer's report on the accepted tenders for an 8,000-k. w. plant shows a total excess cost of gas plant of 7.4 per cent actual, or 14 per cent with certain extras charged to the gas plant for additional ground and building requirements; yet the annual saving in operation is estimated sufficient to annul the excess cost of gas plant in less than two years. Capitalized at 5 per cent interest, this annual saving represents a capital of \$1,485,000, or considerably more than the original cost of the entire gas power station. In other words, the gas plant might have cost twice the actual amount and still realize a definite annual saving over steam power.

A brief perspective, as it were, of the work that has already been accomplished in the gas power field was given by Mr. Bibbins in the conclusion of his paper. The application to railway service has in this country been limited; yet abroad there are many evidences of successful working. A prominent European engineer reported in 1903: "Nineteen stations on tramway work, totaling 6,000 H. P. capacity. These include Barcelona, Tunis, Lausanne, St. Gallen, Poitiers, Orleans and Zurich, from 400 to 600 H. P., each working on either producer or town gas." As a result of this ex-

cellent experience with the Walthamstow electricity station, 650 H. P. has been added to the plant for operating the new tramway system recently constructed. At Buenos Ayres, South America, two plants, aggregating 2,240 H. P., are at work for the Buenos Ayres Great Western and Great Southern Railways. Both use Mond gas. But, eclipsing in interest probably all former gas power railway undertakings is that of the Warren & Jamestown Railway system now under construction. This plant will practically inaugurate the use of the heavy duty type engine, in connection with single phase railway systems in America. The new engine equipment consists of two 500 H. P. double-acting engines of the horizontal tandem type, each direct connected to a 260 k. w., alternating-current engine type generator. These engines are both of the single crank type, but with the tandem arrangement, a power stroke is developed at each half revolution, as in the double-acting steam engine. The gas units will operate in parallel on the electrical end, without necessity of synchronizing the cranks. Owing to the absence of battery and the small number of cars, the plant will be subjected to the most severe test possible. It is estimated that one generating unit will take care of the present maximum demand with two cars starting and two running. Natural gas fuel is entirely used in this territory, and at the present price and heat value will correspond with producer gas delivered at a cost of about two cents per thousand cubic feet. The economy in operating with natural gas is striking. In the old gas plant it is estimated that the cost of power averages 0.75 cent per kilowatt hour, including all items chargeable to operation, except repairs on building and battery; the corresponding gas consumption being 20 cubic feet per k. w. hour.

Among gas power stations in American and British territory we find a large number up to 2,600 H. P. capacity operating on producer, natural and oil gas, and many with the alternating current system with generators running parallel. In fact, parallel operation by gas engines on a large scale was first accomplished in this country at East Pittsburg, with three-cylinder engines of the vertical single-acting type. In view of the success with this type of engine,

it is evident that the tandem and twin-tandem double acting type should be even more suitable. In Great Britain 20 central stations, from 40 to 2,000 k.w. capacity, are in operation, mostly with producer gas.

In the field of electric lighting much has been accomplished. Outside of the Walthamstow station, already mentioned, an interesting plant is the 1,150 H. P. station of the Rockland Electric Company, at Hillburn, N. Y., equipped with horizontal double acting engines, operating on producer gas. As in several other industrial plants using this type of producer, most of the water gas generated is used for furnace heating, while the "air" or "blow" gas, too lean for other purposes, is used entirely in the engine plant. In many respects this system is unique in that it makes possible the commercial use of otherwise expensive water gas, while the cheap "air" gas is rendered useful for generating power.

The operation of close to 100 plants, from 200 to 2,600 H. P. capacity, would seem to indicate that some measure of success has been attained. That one-half of the aggregate capacity operates on natural gas and but one-third on producer gas simply emphasizes the value of this country's natural resources, rather than reflects upon the producer gas system, especially when one considers the comparatively short time that producer gas has been seriously taken up. About 10 per cent of the larger plants, above 200 H. P., operate city and suburban railway systems. The remainder are devoted to many classes of service, such as light and power for city and suburban territory, power for the electrical driving of industrial works, power for operating railway terminals, gas compressing stations, water pumping plants and high service fire systems. A notable example of the latter is the 2,200 H. P. station in Race street, Philadelphia.—*The Engineering Record*.

It is reported that Australia contemplates placing a 30 per cent import duty on gas and oil engines.

Three engines of 40 H. P. each, together with the requisite suction gas producers, were recently shipped from England, destined to drive mining machinery in island of Spitzbergen.

IS GAS POWER MORE ECONOMICAL THAN WATER POWER?

BY H. G. T. HORACE.

The writer and the chief engineer of one of the large water-power plants were having a discussion regarding the cost of construction and maintenance of a gas-power plant, and when the writer mentioned the ultimate figures, the chief engineer exclaimed that if these figures were true, "gas power has water power at a standstill." The answer as to the correctness of the figures was that since builders of gas engines and producers were willing to build plants under guarantee for the constructing and operating figures named, the figures could not be called into question.

That power can be turned out of a gas-power plant for less cost than from a water power plant seems at first thought to be almost incredible, and in order to show how this may be, the writer begs to present the following analysis of costs.

That we may be fair, we will take our data of the water power from a prospectus before us, detailing the cost and probable results in the development of a water power of 20,000 H. P.

From other data we find the estimate given in it compares favorably with several of the larger water powers that have been built, so it is fair to take this one as an example, and, quoting from the figures therein, we have the total cost of the water power plant as \$3,555,000. This includes land, dams and canals, power station and electrical equipment, transmission lines, etc., of a plant ready for continuous operation. This is \$177 per H. P.

The following estimate of the cost of operation, etc., is also taken from the prospectus:

Operating expenses per annum...	\$ 46,000
Interest \$3,555,000 at 5 per cent..	177,750
Sinking fund	100,000
Repairs and depreciation.....	93,000
Taxes and insurance.....	25,000
Total	\$441,750

This plant is located at a point requiring one hundred miles of transmission line.

It is perfectly fair to assume the gas-driven plant as located within this distance of a very large center of population, and yet put it directly at the mine. Hundreds

of mines are as near as Pittsburg, Cleveland, Columbus, Indianapolis, St. Louis, Omaha, Baltimore and numerous cities of from several hundred thousand to more than a million population. So we will place our gas plant at a mine, and will assume 65 cents per ton as the price of slack coal in the hoppers of the producer. This would probably be more profitable than shipping the slack, as the producer uses mostly gas, while the cheap "air" gas is rendered leaving the lump for shipment.

The cost of this plant of the same capacity as the water power ready for continuous operation would not exceed \$2,325,000, or \$116 per H. P.; consisting of gas engines, by-product producers, electrical equipment, buildings, land, transmission lines, etc., as in the case of the water power ready for continuous operation. The operating costs are very nearly as follows:

Labor	\$ 50,000
Interest \$2,325,000	116,250
Sinking fund	75,000
Repairs and depreciation.....	116,250
Insurance and taxes.....	15,000
Total	\$372,500

The plant we are proposing is located at a bituminous mine, and we would only consider a by-product installation, as herein lies a great source of profit.

Every ton of bituminous coal contains from 70 to 85 pounds of sulphate of ammonia. This is worth 3 cents per pound and holds steadily at about this price. From plants in operation it is found that the average net result from the by-products is fully \$1.10 per ton of coal gasified, after deducting the cost of sulphuric acid, etc. used in the process.

It is expected that the water-power plant to which we refer shall deliver power to so varied a custom that it will be practically uniform, as the peak loads of lighting and railway plants shall be taken care of by local plants and storage batteries, so that a load factor of 85 per cent may be assumed, at least for the sake of comparison.

A plant of 20,000 H. P. capacity will deliver, say an average of 17,000 H. P. every day in the year, with a coal consumption of 96,798 tons. As each ton of coal nets \$1.10

in by-products, this tonnage would yield \$106,477. The coal bill for 96,798 tons at 65 cents is \$62,918.

The net result, then, from the by-products is, the coal paid for and \$43,559 placed to the credit of the expense account; and, besides this, gas sufficient to run 17,000 H. P. every day in the year.

The operating account will now stand\$372,500
 Less profit on by-product..... 43,559
 Total\$328,941

In order to make the comparison as nearly correct as possible, we will assume that each plant delivers 17,000 H. P. or 111,100,000 k.w. hours per annum, and that aggregating \$1,111,000, with the following result.

	Total Receipts	Operating Expenses	Net Receipts	Percent of profit on investment
Water power...	\$1,111,000	\$441,000	\$670,000	18.85
Gas power.....	1,111,000	328,940	782,060	33.64

From these figures it would appear that, given a coal mine and a water power equidistant from, say, Chicago, the coal mine can sell slack coal to the gas plant at 65 cents (in which there is a profit), ship the lump at an increased price, transmit current and beat the water power 14.8 per cent in results, not to consider the sale of coal direct.

It will be remembered that the above figures are only for the sake of comparison, as the cost of coal and the price of current will vary in every case, and the latter is put at an extremely low figure.

Granted these figures are true, at this point of the discussion: it will perhaps be said that a water power is so reliable and a gas engine so uncertain.

Is this true? The history of this country will show that there are great "dangers by flood and famine" of water. An unusually dry season and your power is gone; a wet one and something gives way; a cold one and your wheels are clogged with anchor ice. The vicissitudes of a water power entail serious considerations in a large investment.

What are the uncertainties of a gas power plant? But few have kept pace with the development of the engine and producer, and the general belief is that a gas engine is a very uncertain quantity.

There is not in the country a large gas-driven plant devoted exclusively to the development of electrical power that is one

of more than 1,800 H. P., though there are now under construction engines in units up to 4,000 k.w. for central stations. The largest gas engine plant yet built is the one at the Lackawanna Steel Company's works at Buffalo, N. Y.

This consists of sixteen 2,000 H. P. units and eight 1,000 H. P. units. The latter is in fact an electric plant, as it is used for electric light and power. There are all over the country smaller gas-driven electric plants, from 1 to 250 H. P., working with marked success and economy.

In all these plants there is nothing to indicate that a gas engine, properly built and installed, is not as capable of continuous work as a steam engine.

The writer has seen in England a large gas engine running on producer gas that had not stopped in 400 days, and had run 700 days with one stoppage.

There are in this country about half a dozen builders of gas engines who are prepared to install and guarantee the successful operation of engines of 2,000 H. P. and over. They will also guarantee sufficiently close regulation for successful work on electric lighting.

As they are among the oldest and most responsible engine builders in the country, their willingness to stand back of the gas engine should insure its reliability and place it on an even footing with the steam engine.

The gas producer is as simple in its operation and positive in its results as a boiler. There is nothing more to go wrong or get out of order than in a steam boiler. It requires about the same amount of attention and the same class of labor. There is one plant in successful operation of the by-product type in this country, one more now under construction and eight or ten in England. It is found that our coals work well treated by this process, and the yield in by-products is about the same as in the plants abroad.

If there were a water power of 20,000 H. P. within 100 miles of any of the large cities of the country, how eagerly it would be taken up and millions expended in improving it? This is because our grandfathers ground their grain with the old wheel, and it is a tradition that it is the one economical and reliable power.

Yet there are within less than 100 miles of many of these cities practically inexhaust-

ible coal fields, from which, unless figures lie outrageously and the guarantees of the great engineering companies in the country are of no account, power may be taken at less first cost, and with greater economy in operation than from any existing water power, and, though water power may not yet be at a "standstill," surely it can not compete with gas from coal except in the

outlying districts.

With all this there is one great and gratifying feature in this exposition; it is that, as it is shown that power can be delivered more economically from the coal fields than from a water power, Niagara may be spared us, and with it many more of the picturesque streams that are being chained to the wheels of ruthless progress.—*Power.*

THE EFFECT OF HYDROGEN ON GAS ENGINE COMPRESSION.

BY GEORGE M. S. TAIT.

As many are aware, one of the main difficulties encountered in the steady performance of a producer gas operated gas engine is caused by the fluctuation in the quality of the gas generated by the producer, and as a proof of this we have all noticed the excellent performances obtained from gas engines operating on illuminating or natural gas, of a fixed analysis, as compared with the somewhat varying runs obtained with the same engines when operating on producer gas. This absence observed in the operation of the engine is more noticeable in conjunction with the suction type of producer where no gas holder is employed, the reason for this being that momentary variations which always occur in the present type of producer are not felt so much where a large gas holder is employed, as the latter gas has an opportunity for mixing with the other gas already in the holder, with the result that the supply drawn by the engine is more or less of a constant quality.

In acknowledging, therefore, that the quality of producer gas varies, our next step is to ascertain the cause of this variation and to indicate, if possible, a remedy therefor.

The theoretical analysis of producer gas made from anthracite coal would be about as follows

Per cent by vol.

Carbon monoxide	27.0
Hydrogen	12.0
Marsh gas	1.2
Carbon dioxide	2.5
Nitrogen ..	57.0
Oxygen ..	0.3

B. T. U., 137.5 per cubic foot.

Unfortunately, however, in practice the quantity of carbon monoxide will be found

to be much lower than the above, while carbon dioxide and hydrogen will correspondingly increase. This change in the gas is, however, not shown by the usual calorimeter test, due partly to the fact that as the carbon monoxide decreases it is offset as far as heating value goes by the increase of hydrogen; this increase sometimes causes a rise in B. T. U. above the figures first mentioned.

However, a gas high in B. T. U. is not necessarily a good gas for engines, especially if by this increase we have to sacrifice high compression in order to guard against preignition; and as, in the case of the present producers, high B. T. U. generally means a high percentage of hydrogen, this increase in heating value proves to be rather a detriment than otherwise to the engine performance.

The engine builder is aware that his compression must be governed by the maximum amount of hydrogen which his engine is liable to encounter at any time during the run, and he, therefore, is forced to put the compression much lower than he otherwise would do in order to safeguard himself against preignitions. It would appear, therefore, that if a gas sufficiently rich, but at the same time having little or no hydrogen, could be manufactured, ideal results would be obtained.

That this is the case has been demonstrated by the wonderful results obtained in Europe from gas engines operating on blast furnace gas, which, although of a very low heating value, is free from hydrogen, and, consequently, admits of a very high compression on the engines. In support of this argument, it is interesting to note that gas engines are now operating on 9,500 B. T. U. and even less per B. H. P. on this gas.

where the compression has been raised to 200 pounds, whereas the same make of engines operating on producer gas of a richer quality, but containing hydrogen, are found to consume from 11,000 to 12,500 B. T. U. per B. H. P., but with a compression of only 130 pounds. The present outfit for the manufacture of producer gas comprises a producer, scrubber, purifier, and in some cases a gas storage tank or holder. The fuel is burred incompletely in the producer either by forced or induced draft, the resulting gas passing off to the engines.

Now in practice it is found that the fuel bed would get intensely hot if supplied with air alone, and as this condition would cause undue clinking of the fuel, as well as a lean gas, there is introduced steam or water vapor along with the incoming air for the double object of lowering the temperature of the fire by the heat-absorbing property of the steam, and in cases where the temperature is high enough the dissociation of said steam or water vapor occurs, the oxygen uniting with the carbon of the coal to form carbon monoxide, while the hydrogen passes off in the gas, enriching the same materially.

The one defective feature of this system is that the percentage of hydrogen is continually changing, owing to the varying temperatures of the fire, which at one time is too cool to decompose the steam and merely allows the same to pass through the fuel bed in a superheated condition; while at other times when the demand for gas is greater and the rate of combustion consequently higher, the resultant rise in temperature dissociates the steam, making a variation in all of from 5 to 20 per cent of hydrogen in the gas by volume.

The engine builder, being aware of this unknown quantity in the form of hydrogen upon which his engine has to operate, is compelled to sacrifice high compression and the incident economies therefrom in order to guard against preignitions, and to lower the compression so that the working efficiency of the plant is very much impaired.

That the compression at which the engine operates has a powerful effect on the economy of the plant is well set off by the performances of a certain well-known make of engine on producer gas containing hydrogen, and blast furnace gas containing no hydrogen, as follows: In the first instance

the engine, the compression of which was set to 120 pounds, uses 11,500 B. T. U. per B. H. P. per hour, while in the second instance engines of the same make with a compression of from 170 to 200 pounds are operating steadily on 9,500 B. T. U. per B. H. P.

This enormous saving accomplished solely by increasing the compression, is very obvious, and when it is realized that these results are only possible where hydrogen is eliminated from the gas, it would seem that a producer which would supply a gas sufficiently high in carbon monoxide to obviate the necessity of too large a cylinder would give ideal results in engine practice.

Having this object in view, producer manufacturers have long been experimenting with other diluents to take the place of steam, but until very recently nothing satisfactory had been accomplished. Now, however, there are two or three plants in the course of erection upon which a new system is being tried, in which the steam is replaced by a diluent consisting of cooled exhaust gases, which bids fair to answer all requirements.

The action of this substitute for steam is said to be very marked, the carbon monoxide in the exhaust gases burning back to carbon monoxide when passing up through the fuel in the producer, absorbing heat, while at the same time the analysis of the gas shows a higher percentage of carbon monoxide, which, along with the high compressor admissible, is expected to offset the absence of hydrogen.

The special feature of the gas in this system that should recommend itself to engine builders is the fact that the analysis remains fairly constant under varying loads, and owing to the absence of hydrogen and consequent dangers from preignition very high compressions should be safely carried without danger accruing therefrom.

It is expected when the installations embodying the improvements are perfected a solution may be found for the difficulties heretofore experienced.—*Scientific American*.

It is said that more than a third of North Dakota is underlaid with lignites, nearly all of which may be used as a source for power in gas producer and gas engine plants.

THE GAS ENGINE IN PRACTICE

As we have many times intimated, the gas engine is coming along rapidly. We are far from decrying the steam engine in its ordinary form—it is and probably will long remain the mainstay of power production. But the gas engine is here and is doing good work at a cost which, in many cases, compares well with other engine costs. This is not saying that a street railway load is the gas engine's long suit or that there will always be economy in using gas engines. The stock arguments against such engines are three: First, that they will not hold their speed well enough for irregular loads; second, that they are, when the producer plant is included, very expensive, so that the fixed charges eat up the possible profits; and third, that they entail an abnormally heavy cost for repairs. Let us take up these in the light of the present papers and see what weight is properly to be attached to them in the existing state of the art.

To begin with, a 4-cycle gas engine is, cylinder for cylinder, at a disadvantage compared with an ordinary steam engine. But, on the other hand, a two-cylinder, double-acting gas engine, such as is now produced for large work, will give the same regularity of impulse as a single-cylinder Corliss engine, while a four-cylinder gas engine will give a cycle like that of a compound steam engine. Thus similar regularity of effort merely means a duplication of cylinders, which appears in the capital and maintenance accounts, but gets there just the same. By the same token, the governing should be, and is, about the same in the two cases. The overload capacity of either machine depends on its rating, and any less overload capacity of the gas engine consequently appears in the costs to be discussed. It is a matter of record that gas engines can successfully drive alternators in parallel, which means that the governing is actually good. Their rotative speed is also fully up to that of Corliss engines of similar output, which means that in the two cases the generator design is about the same. Now as to cost, it is at the present moment true that a gas power plant is somewhat above a steam plant. This, however, affects the cost of the power

produced only in so far as it raises the fixed charges. In the bids on an 8000-kw. plant, the excess in cost between the favored gas plant and the favored steam plant was about 8 per cent, which would raise the fixed charge on the latter pro rata to partially offset the fuel economy, which was guaranteed at 1.61 lbs. coal per kw-hour, as estimated from the engine performance.

Let us now touch upon the much-mooted question of repairs to gas engines. Two actual stations give pertinent data. One case, that of an 800-kw station at Bradford, Pa., operating on a station load factor of only 19.54 per cent, showed a total works cost per kw-hour of 0.825 cent, of which 0.01 cent was due to repairs on engines. This can hardly be rated as excessive. A second plant, belonging to the London Metropolitan Boroughs, on a load factor of 15.2 per cent, gave a total for repairs, including all, of 0.048 cent in a cost per kw-hour of 1.05 cents, the station capacity being 2000 kw. The average of eleven steam generating plants in the same district gave, with an average load factor of 17.25 per cent, a cost per kw-hour of 1.41 cents, of which repairs ran to 0.218 cent. Of course, such comparisons are a bit uncertain, but it is sufficiently clear that the gas engines were not the source of severe repair.

These figures show at least that the gas engine is in the game, and when one considers that they were derived from small units operating at bad load factors, supposedly disadvantageous for gas engines, the results are all the more striking. The long and short of it is that when one undertakes with a steam engine to go up against a thermal efficiency of 25 per cent or more, there must be very substantial gains in fixed charges and repairs to come out even. And as to plant efficiency, there is too much difference between less than 25,000 B. T. U. per kw-hour and 40,000 or more to be easily overcome. We believe that the next few years will see considerable gains in the efficiency of both kinds of engines. The gas engine has already proved a valuable stimulant in steam working. The fact that several American electric railway plants are being equipped with gas engines gives promise of livelier competition in the future.—*The Street Railway Journal.*

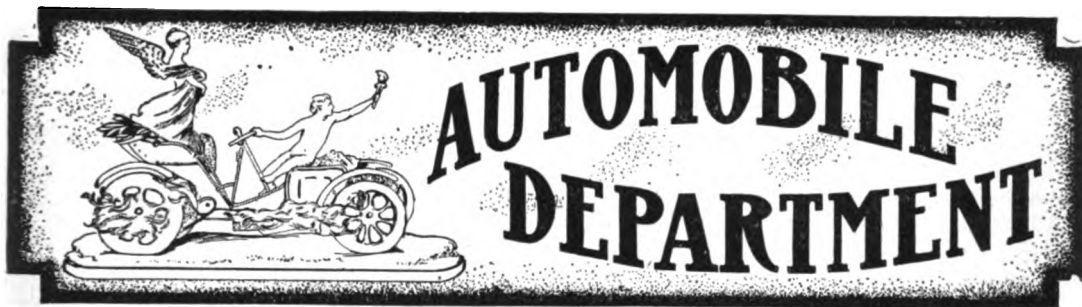

Owing to circumstances which have arisen we are prevented from continuing Mr. Haenssger's article on European conditions in this issue. We expect, however, to continue it in the December or January numbers.

A special motor car has been built in England for use on the sands of the Soudan. It is equipped with a 20 H. P., three-cylinder engine, which will operate on kerosene or gasoline. Provision is made for three days' supply of fuel and water. The car wheels are enclosed in metal plates of light make, hollowed out, only the solid rubber tires being exposed.

The possibility of the adoption of the auxiliary exhaust on automobile engines, as discussed in another column, is of interest to the manufacturers of stationary engines of this type. Quite a number of stationary engines have been using the auxiliary exhaust for several years, and the manufacturers point out special advantages in this method of exhaust, which certainly are convincing to many engine purchasers. The same advantages would seem to hold good in the case of an automobile engine. At the same time, the opponents of the auxiliary exhaust system claim that the advantages are more theoretical than real, and that the results of tests will not show an appreciable difference between two engines differing in this respect, but otherwise the same.

The importance of a good coil in the successful operation of an engine, whether stationary, marine or automobile, is not always realized by the user, or at least not till he finds, after days of trouble, that a poor coil has been the cause of his engine not operating properly. Many times the poor results in an engine's operation may be en-

tirely eliminated by simply changing coils. Particularly with automobile engines must there be an efficient coil. The user may think that when his automobile is running on a smooth, paved street is the time to test his coil. On the contrary, however, the time when every impulse of the engine counts is when the car is going up a hill, or over a rough road under full load. A failure to ignite every charge under such circumstances may stall the car. Under these conditions the coil and the other parts of the ignition mechanism must operate perfectly, and then is the time when a coil proves its merits.

The Missouri, Kansas & Texas Railroad Company has decided to put in operation an interurban automobile service over its branch road between Denison and Sherman, Texas.

A mistake that is frequently made in gas engine design is to assume that the bolts through the connecting rod brasses have little or no work to do beyond merely holding the rod and crank-pin together, inasmuch as the ordinary type of gas engine is a single-acting machine, and the rod is supposed to be always in compression. Such is not the case, however, since the force required to accelerate the piston on the ends of the stroke is always considerable, and with short connecting rods and heavy pistons it may be, momentarily, equal to or even greater than the normal pressure due to the explosion. Moreover, when an engine is running without charge due to its momentum, the piston is not cushioned as it is under working conditions. Hence the importance of proportioning such bolts so that they shall be strong enough to transmit the full power of the cylinder through the connecting rod in tension as well as in compression.—*Machinery*.

POSSIBILITIES OF THE AUXILIARY EXHAUST

BY HAROLD H. BROWN.

While the auxiliary exhaust port is by no means a new feature on either stationary or automobile gasoline four-cycle motors, it has only recently assumed any very great prominence in automobile practice. As there seems to be a great deal of uncertainty among a great many people as to its usefulness and possibilities a discussion of them may be of profit.

The auxiliary exhaust port consists simply of an opening or openings in the side of the cylinder which are uncovered by the piston toward the end of its outward stroke, and which thus allows a certain portion of the exhaust gases to escape through this port to the atmosphere without first passing through the main exhaust valve.

Probably one of the first examples of the auxiliary exhaust port applied to automobile practice seen in this country was on a Soncin motor fitted to a Perfecta Darracq tricycle and imported to this country in 1900. This motor was air-cooled, rated at about 4 H. P. A series of holes were bored in the cylinder walls near the end of the stroke, and a collar around the cylinder with corresponding holes was so arranged that it could be revolved by a lever at the hand of the operator so as to open or close the corresponding holes in the cylinder. The object of this latter device was to keep down the noise of the exhaust, when necessary, and to render starting easy.

The auxiliary exhaust port has been used on the Fairbanks gas and gasoline engines for the past eight years. These engines are of the horizontal stationary type. The manufacturers claim that by opening the main valve, after the auxiliary exhaust port is well opened, the pressure and temperature of the gases in the cylinder are so reduced that warping and burning out of the main valve is reduced to a minimum.

So far as the author has been able to learn, the makers of this engine have discovered no practical or theoretical drawbacks to the use of the auxiliary port.

There seems to be a generally prevailing opinion that the main object in applying the auxiliary port is to increase the lead of the exhaust opening, and it has, therefore, been argued that as this object can be accom-

plished just as well by suitably designing the exhaust valve cam, the exhaust port is little use except to help keep the exhaust valve cool. The fact of the matter is, however, that the exhaust port, if properly designed, will allow us to delay the opening of the exhaust, both main and auxiliary, and thus give us more power on the working stroke without at the same time increasing the back pressure on the exhaust stroke.

It will be evident, upon a moment's reflection, that in order to keep the pressure down to a certain point at the end of the working stroke we must, as the speed of the motor increases, either cause the opening to occur earlier in the stroke or increase its dimensions. It has been found, however, that with a comparatively small valve the back pressure may be kept well down, provided we give the valve enough lead. It will therefore be evident that a comparatively large exhaust opening is only necessary during the lead or outward stroke. This we can supply by means of our auxiliary port.

At present there seems to be a tendency to place both the inlet and exhaust valves in the heads of the cylinders, and, as this position necessarily limits their size, any device which will allow us to keep down the lead of the exhaust without increasing the size of the main exhaust valve is likely to assume considerable importance.

When the auxiliary port was first applied to four-cylinder motors and connected to a muffler, a difficulty was encountered which caused one maker—temporarily, at least—to abandon this feature. This was owing to the fact that as all four ports were piped direct to a common exhaust pipe, the hot gases from the cylinder on the working stroke tended to rush into the port of the cylinder on the suction stroke and ignite the gases therein prematurely. One maker of an air-cooled, four-cylinder motor has overcome this difficulty by placing ball checks between each port and the common exhaust pipe. Another method that, of course, might be used, would be to use separate mufflers for each cylinder or long individual exhaust pipes.

There is one possibility of the auxiliary exhaust port which so far seems to have

been entirely overlooked, and that is the economy of fuel that can be gained by at all times working under full compression, as is done in the De Dion system of exhaust throttling. In this system the exhaust may be throttled by regulating the lift of the exhaust valve; the result is that, owing to the cylinder being partially filled with dead gas, only a portion of a new charge is drawn into the cylinder on the suction stroke. Working under full compression at all times, the fuel economy is high.

The system has one great drawback, however, and that is that it can not very well be used with mechanically operated inlet valves. If we throttle the inlet of a motor provided with auxiliary ports which are freely open to the atmosphere, the following will be the operations which take place. Owing to the action of the throttle a vacuum more or less complete will be maintained until the port is uncovered, when the

dead gases of the previous explosion will rush in and raise the pressure to nearly atmospheric. The result is that the compression pressure will be the same at all times, regardless of the position of the throttle; but the amount of mixture admitted can, of course, be varied by the throttle. We have thus the following advantages over the De Dion system: First, mechanical valves can be used, and, second, we have no back pressure to overcome.

To summarize, the auxiliary exhaust port offers the following advantages: First, it keeps the main exhaust valve cooler and thus saves the trouble of regrinding to a great extent. Second, it reduces the amount of lead necessary at high speeds, and thus gives us more power on the working stroke. Third, it allows the motor at all times to work under full compression, and thus gives greater fuel economy.—*The Automobile.*

SOME COMMON TROUBLES AND REMEDIES.

Any cylinder of a multi-cylinder engine should develop as much power as any of its neighbors. If a cylinder is badly "out," the fact will be indicated by the sound of the exhaust, which will "beat," sounding a little louder or softer for that particular cylinder. A late ignition in one cylinder will produce a loud exhaust from that cylinder, if the others are correctly timed, and an early ignition will cause that cylinder to knock on hills or when gearing up.

To time all the cylinders alike, the first step is to mark the flywheel, if it is not already marked, and turn the motor over slowly by hand, with the gasoline shut off, to determine if the timing contact is made with the crank in the same position for every cylinder. If it is not, the timer must be adjusted, according to its style, till this point is assured.

Next adjust the tremblers to produce the same note as nearly as possible, aiming at rapid vibration so far as the construction will permit. The vibration must not, however, be so rapid as to make a weak spark. Some tremblers are by design much more rapid than others, and it is well to note the appearance of the spark in the air by disconnecting a

cable from its plug. A 5-16-inch spark is generally sufficient. See that the contact points of the tremblers and screws are clean and evenly matched.

Now start the motor, and adjust it to run free, first at low, then at high speed. Hold down all the tremblers except one, and note by ear the resulting speed of the motor. Run on the next cylinder alone in the same way, and so on. The speed should not sensibly vary for the different cylinders, whether the motor is set to run fast or slow.

If the speed should vary, it may be that the coil is partly short-circuited, giving a weak spark, or that readjustment of the trembler will equalize that cylinder. Trial of the coil on another cylinder will show if the fault is in the ignition. More probably, however, the cause is to be found in the quality or quantity of the mixture. Thus, two unequally adjusted carbureters may be employed, or the inlet pipe branches may be of different lengths, as is sometimes the case. If the inlet valves are automatic, it may be that the valve springs are of unequal stiffness, a weak spring giving more power at slow speeds, but less at high speeds, owing to the valve failing to close promptly

before compression has begun. Similarly, it may be found that one exhaust valve closes sooner or later than the rest, or that one cylinder is leaking through valve or piston rings, so that the quality of mixture actually utilized is less.

Sometimes the trouble is more fundamental. I knew of a "double opposed" engine turned out in considerable numbers a year or two ago, in which, to get the valves in line, the makers had actually extended the valve chamber of one cylinder an inch or more further than the other, making that compression space so much the larger. Of course the other cylinder did most of the work, and there was no remedy for it but to change the pistons to alter the compression space.

A weak spark, not too weak to jump the plug terminals under compression, will require a greater advance of the timer than a strong spark for the same speed of the motor. A hot spark, on the other hand, is liable to be obtained at considerable cost for batteries, and the primary current may burn or fuse the trembler contacts, causing sticking and irregular firing. There is some danger also of breaking down the insulation of the secondary winding, and short circuiting the coil. Three fresh cells of a good dry battery will work most coils, but as the cells weaken, four, five, or even six, may be required.

Lost compression may be due to the exhaust valve being sprung, or to its seat, if removable, being sprung. Either condition may be indicated by the stem being worn bright on one side, and, of course, if the valve is sprung it will not grind to a smooth surface all round, while the same is true of the seat if it is the cause of the trouble. A protracted grinding, followed by suitable filing of the end of the stem so as to leave the timing unchanged, is the usual remedy.

Leather or canvas-lined brakes which soak up oil should be uncoupled and washed with kerosene or gasoline at suitable intervals. If it is the foot brake—next to the gear case—that gives trouble, it may be possible to mend matters by substituting grease for oil in the gear case. Before this is done, one should make sure that none of the shaft bearings are going to be "stirred" by the change.

Owners of cars equipped with the older

form of De Dion carbureter, as made a couple of years ago, are aware that this carbureter is extremely sensitive to wrong adjustment. It has no throttle, but instead a shutter which, when set for the highest motor speeds, diverts some of the indrawn air by separate passage around the spray nozzle, to dilute the mixture. It requires to be adjusted by hand for different motor speeds, and is very sensitive at the point where the shutter begins to open. The best way to manage it will depend somewhat on the gasoline level as determined by the float. If the level is a little low, the shutter may never require to be fully open. If, on the other hand, the air intake is partly clogged, as by the wire gauze screen covering it being filled with dust, the suction may be so strong as to require that the shutter be kept open. The best way to start may be to open the shutter wide and prime the carbureter. It is better, however, to avoid priming after a short stop, and to learn the position of the shutter at which the motor can be started with a turn or two. If the shutter is closed a little too much, it may be impossible to start at all. In this event the shutter should be opened wide, and the relief cocks, if any, also opened; then two or three turns will bring the right mixture. The gasoline level is regulated by unscrewing the bottom plug and adjusting the position of the nuts on the weighted needle valve on which the float acts. The best level is at or very slightly below the top of the spray nozzle.

If you use a storage battery for ignition and it is found after a time to discharge more rapidly than it should, the cause is likely to be found in some portion of the active material having loosened from the plates, and possibly, bridged between two plates, causing a short circuit. If the rated capacity in ampere hours is known, and it is inconvenient to take out the plates for examination, the battery may be taken out, charged, and discharged through a resistance sufficient to give a current of, say, 2 amperes. Note the time taken to discharge. If materially less than it should be, it shows that the trouble is in the cells, and not in an external ground or short circuit, and the faulty cell must be found and opened. A voltmeter test before discharge is com-

plete will indicate the bad cell, if one is worse than the other, and it must be disconnected, opened, the plates taken out, separators removed, and the plates washed in clean water to remove any loose active material. Of course, it is assumed that the acid solution has not been allowed to fall below the plates, and that it has been maintained of proper density—1.25 when the cell is fully charged.

If the cell has been short-circuited by loose active material, the plates are probably sulphated, and will require slow charging and discharging, several times repeated, to bring them into condition.

A carbureter which begins well, and ends by giving an over-rich mixture, may have a waterlogged float, a leaky float valve, or a bit of dirt in the valve; or the spray nozzle may have unscrewed or something else worked loose inside.

If the float is cork, it should be dried thoroughly, shellacked and readjusted to close the valve at the proper level, which is at or just below the tip of the spray nozzle. This readjustment may involve weighting it or shifting its position on its

stem. The latter job is best done by some one skilled in the use of the soldering iron.

A copper float, if gasoline has got into it, should be immersed in warm water, when the escaping vapor will locate the leak. When all the gasoline has been expelled and the float is cold, the leak should be closed with the least amount of solder practicable, and the float re-tested.

The following are the principal causes of overheating in gas engines: Too rich mixture, poor cylinder oil, not enough cylinder oil, broken or otherwise defective pump, slipping pump drive (if belt or friction), clogged water pipe, water jacket not free of sand or other obstruction (I have known motors to be delivered with the water jackets half full of sand which had never been cleaned out), radiator dirty outside or oily inside; not enough water. Most of these things are easily located, the process of elimination excluding most of them on a brief inspection or from knowledge of other symptoms. The beginner's danger is of failing to keep the whole list of possibilities before him till he has exhausted it.—*The Motor Car.*

E N G I N E B R A K I N G .

We have received an interesting letter from Mr. Edge upon the subject of engine braking. He, like ourselves, is a believer in using the engine for retarding purposes as well as for propulsion. Now many cars are made with the brakes inter-connected with the clutch. That is to say, if the foot brake is applied the clutch is automatically taken out, and the same remarks apply to the hand brake. This means that when either of the brakes is in operation the car can only be checked through the brakes, as the engine is entirely disconnected from the road wheels. Some cars are made with the hand brake only inter-connected with the clutch, and on these the pedal brake can be used without of necessity taking out the clutch. Then there are those cars in which neither the pedal nor hand brake has anything to do with the clutch, and personally we think this is the best arrangement for the majority of cars, and we have more than once dismantled the connections between the brakes and the clutch on cars that we

have had. The reason we object to the inter-connection of the brakes and clutch is that we can never use the engine and one or both of the brakes in concert. Many hills and slopes can be taken by switch or throttle alone, but if the application of the pedal or side brake disconnects the engine, it means that directly more retardation than the engine can afford is required it can only be had by the brakes, whereas the best way is to use the engine and then to supplement it with one or other of the brakes as occasion requires, and in nine cases out of ten only a light continued application of the side brake is wanted, or a touch here and there of the pedal brake at the bends or steeper sections of the descent.

There appears to be an idea prevalent that to switch off the engine down a hill, and to let it thereby exercise a steady checking influence upon the car, is very bad for the engine, and that it is much better to use the brakes for this purpose. We can only say that an engine which

would be damaged in this way would be such a hopeless contrivance that it would never propel a car up a hill, if, indeed, it would run it on the level. On the other hand, we may be asked what is the good of using an engine in this way, as it is no more trouble to put on the brake or brakes? Our reply to this is that the great advantage of engine braking is that it is so regular in action that the car is much less likely to side-slip, and, in addition to this, it is not only regular but gentle, though it is astonishing what a retarding effect it has. In addition to this, the brakes themselves run for very much longer distances without requiring adjustment and without overheating, so that it not only means safer driving, but a positive save in wear and tear, not merely to the brakes themselves, but to the car as a whole.

Some little discretion is required in using the engine as a brake. No hard and fast rules can be given, because cars differ. Preferably the switch should be upon the wheel, so that the current can be cut off in the easiest possible way, but there is not much in this. It is practically as convenient if it is on the steering column or just at the side of the driver. If, on the other hand, it is placed upon the dashboard in a position which the driver can not reach, he must give up the idea of switching off unless he has an intelligent friend by his side who will do it for him. As a rule, it is not a difficult matter to move the switch to an accessible position, but leaving the switch out of the question altogether, the engine can be controlled quite as well by the throttle, and we have one car which we always drive this way. When we come to a hill on which we desire to slack, we simply close the throttle, and we may say, from experiments we have made, we have found the retarding effect is practically as great as switching off the ignition, though some motorists stoutly aver that it is not. At the same time, this closing of the throttle has its objections, because when it is opened again the engine generally runs rather badly for a few revolutions, owing to the carburation being upset. This, however, can frequently be overcome by a little thought, and if the carbureter is provided with an automatic extra air supply it will generally check itself, or if it has not got an automatic

air supply the driver can regulate it by hand. It only requires a little judgment, as by cutting off the air for the first few revolutions after the throttle has been opened again it will be found that the engine will pick up comfortably so long as the ignition is properly positioned.

In all these things some common sense must be used. For instance, after the engine has been switched off, it is not good driving to switch it on and do nothing more, because there may be a considerable shock from the renewed impulses of the engine. What should be done is, at the moment of switching on or opening the throttle the clutch should be slipped very slightly, so that the engine, as it passes through the transitional stage from braking to driving, will do so without any shock to the car or itself. At the same time, the clutch must only be slipped very slightly, as otherwise the engine will stop. These operations, which sound rather formidable on paper, are nothing when actually driving, and one does them automatically after a few times, so that one's friends upon the car are quite unaware that the brake has not been used in the ordinary way, or if, indeed, they make any remark at all, they comment upon the extraordinary smoothness of the running of the car, and in some cases upon the fact that there is no grinding sound from the brakes downhill. There is one little warning which must be given here. Again it is a general one, and depends upon the car. It often happens that one may drive fifty or sixty miles using the engine as a brake, and without touching the pedal brake at all. Perhaps the side brakes may be used down a long, steep hill to help the engine to steady the car, but it is quite likely that the pedal brake will not be touched. Now many cars have a habit of throwing oil out of the gear box on to the pedal brake, and, although the majority of pedal brakes are now unaffected by oil after a few revolutions, it is well to remember that a brake which is not often used gets more thickly coated with oil than one that is used constantly, and it will take longer to come into action, so that it is advisable, before entering a town after a long spell of clear running, to use the pedal brake.

In conclusion, it should be clearly understood that a certain amount of prac-

tice is required in engine braking before one can do it nicely and without, perhaps, stopping the engine once or twice. For instance, the engine should always be switched on or the throttle opened in time to have it going well while there is some down gradient left and a little weigh upon the car. If it is left too late there will be some slight shock. Then again, the clutch should always be taken right out if it is found necessary to stop the car entirely, engine braking not being intended for sudden stops, but for corners and traffic slacks and steady retardation down hill. By the way, engine braking is another example of the influence of the steam car. It would probably have scarcely been thought of if it had not been for the throttle of the steam car, which, as it opened or closed, either propelled or stopped the car as required, the brakes being a mere subsidiary apparatus, only to be called into use on emergency. This is the ideal form of control, and the more nearly the gasoline car can conform to it the better. Many gasoline cars now approximate very closely to the steamer in this respect, but their owners take no advantage of the fact, and continue to drive in the old way, which was simply

"out clutch and on brake." They had to drive this way in most cars four or five years ago, when throttles were almost unknown, and when switches were almost always placed out of the driver's reach. Speaking generally, we prefer the throttle brake to the switch, because if the carbureter is properly designed the engine can be set to work again more gently than if the spark is suddenly switched on. And there is no gentle way of doing this; as the spark is either off or on, there is no gradual opening up as with a throttle. At the same time, many throttles, or we should say carbureters, do not act at all gently, and in these cases the spark is as good or better, provided the explosion of the unfired charges in the muffler are not objected to, and also that the muffler will stand them without bursting or blowing its packing at the exhaust pipe joint. On the other hand, some mufflers do not explode their contents when the current is switched on again. There are various reasons for this, which we may discuss at some future time, as comparatively little attention has been given to this very annoying and startling noise, which most horse drivers think is made purposely to startle their horses.—*The Autocar*.

QUICK AUTOMOBILE DELIVERY.

For three days last week a two-cylinder 16 H. P., Acme commercial delivery car was used in a test of quick and economical delivery of packages in Chicago and its suburbs. The car was one of the regular commercial cars built by the Acme Motor Car Company, of Reading, Pa., and for which Devlin & Co., 1407 Michigan avenue, Chicago, are the Western distributors. The test was made for Carson, Pirie, Scott & Co., one of the leading wholesale and retail dry goods concerns of Chicago.

The total distance covered by the car in the three days was 158 miles, the average speed being 8.1 miles, including stop-

An average distance of 7.2 miles was run on 1 gallon of gasoline, while over 90 miles were run on 1 pint of lubricating oil. It required an average of .139 gallons of gasoline to cover 1 mile and .011 pints of oil.

Two trips were made on the first day,

October 3. Starting with 108 parcels at 9:15 a. m., the car started for the South Side, carrying besides the eighteen-year-old driver, the assistant shipping clerk, the regular horse wagon driver and the package boy. The car was driven as far south as Seventy-fifth street, completed the delivery of all the packages and returned to the store of Carson, Pirie, Scott & Co. at 1:45 p. m. Another trip over the same territory was started at 3, the number of packages being eighty-seven. Three hours after the start the car was back at the store. All told, probably 50 miles were run, 7 gallons of gasoline and $\frac{1}{4}$ pint of oil being consumed.

Only one trip was made on the second day, it being started from the store at 12:30 p. m., the destination being Oak Park, Harlem and River Forest. The car carried 130 packages and four persons, and covered the route in 6 hours, the distance being over 50 miles. All told,

6 gallons of gasoline and $\frac{1}{2}$ pint of oil used.

With a load of 124 packages, besides the men, the car was started out at 9:15 a. m. on the morning of October 5 for North Chicago and Evanston, delivering its last load at 1:15 p. m. A second trip was started at 4:20 p. m. from the Evanston warehouse of the dry goods company, and thirty-one packages delivered in 1 hour 25 minutes. The consumption of gasoline for the day was 9 gallons and that of oil 1 pint. The summary of the trial is as follows:

Number of trips	5
Total mileage	158
Average mileage per trip.....	\$1.6
Total time	19 hrs. 25 min.
Average miles per hour.....	8.1
Average time per trip.....	3 hrs. 53 min.
Character of load.....	packages
Gasoline used	22 gallons
Lubricating oil used.....	1.75 pints
Miles per gallon of gasoline.....	7.2
Miles per pint of oil.....	90
Cost of gasoline.....	\$2.31
Cost of gasoline per mile.....	.014
Cost of lubricating oil.....	.14
Cost of lubricating oil per mile.....	.0008
Total cost of gasoline and oil per mile.....	.015

—The Motor Way.

THE GASOLINE ENGINE PISTON.

The gas or gasoline engine piston receives very little attention at the hands of writers on the subject, especially so in trade journal and magazine articles. It is a very important part of the engine. It is the part that has to do with the packing of the cylinder to prevent the escape of the explosive force, with the compression of the charge, with the inhalation of the gas and air and with the carrying of the cross-head end of the connecting rod. At the same time it must be so loosely fitted into the cylinder as to allow it free and unobstructed movements therein.

It is therefore quite important that the cylinder in which it has to work is a true one, perfectly round, and of uniform diameter from one end to the other or at least so far as the piston travels. There can be no such thing as securing the best service that an engine is capable of unless the cylinder is as perfect as machinery can make it. But a perfect cylinder alone will not bring about the best results. The piston must be a perfect-fitting one, thoroughly true in its circumference and diameter from one end to the other.

The gasoline engine piston by reason of the severe service it is called upon to perform must necessarily be heavier, power for power, than the steam engine piston. All the force exerted upon it comes from one end of the cylinder only. Consequently it is usually of the tank or bucket type, closed at one end and open at the other to receive the cross-head end of the connecting rod. To carry its weight with the least amount of wear to itself and the cylinder it is usually considered best to make it of

very liberal length, and to cast the cross-head stays somewhere near the middle part of its length so that this extra weight of the cross-head pin and piston is about equally distributed over the piston length. These pistons are usually made out of gray iron castings, and it is not possible to make them as true and perfect as they should be with a lathe tool alone. It is best after turning them as true as a lathe will make them to use an electric grinder to grind off all the rough tool marks and high places left by the lathe tool. You see it is the exception rather than the rule to get a casting from the foundry that is of the same consistency throughout. There are bound to be some hard or soft spots, and the tool will jump over a hard place without cutting as deep as in the average consistency and it will cut deeper in the soft spots. This, you see, is the cause for imperfect pistons and cylinders where the lathe tool alone is depended on. But if the grinder is used all the hard points will be brought down on a level with the general contour, and if any soft or low points are found the entire surface can be ground down to the lowest point. Every gas engine builder points with pride to the compression or packing quality of the piston in his engine. Especially so if he has succeeded in getting both piston and cylinder in good shape, and there is no excuse for getting any bad ones if the proper care is exercised in their manufacture.

Compression is in fact a pretty good test of the condition of the piston cylinder rings, etc. If by turning the flywheels over onto the compression stroke and you can hear

the escape by the rings, either the cylinder is not round, the piston defective or the rings imperfect. But if when turning the wheels upon the compression stroke the piston rebounds like a rubber ball you can safely conclude that there is a good-fitting piston and rings. An overload on the engine is hard on the piston and rings, but is much more injurious to them when they are not well fitted to the cylinder. Constant impulses necessary under a heavy load cause intense heat, the partial escape of which past the piston burns the lubricating oil and soon there is a dry piston.

The piston rings are intended to prevent the escape of the explosive pressure around the piston. They are set into grooves cut into the circumference of the piston. They are usually made out of the same kind of material as the piston and cylinder—that is, out of good tough gray iron. They are turned out a perfect circle, a little larger than the cylinder into which they are to fit. A piece is then cut out of their circumference so that when the ends are sprung together they are just of the diameter of the piston and will just fit into the cylinder. But when a piece is cut out of a true ring and the ends spring together it fails to remain a true ring, and becomes slightly oblong so long as the ends are kept together. Consequently it is necessary after the piece is taken out of the ring to press the ends together, clamp them in that position and turn their outer circumference again to a true ring. When this is done properly they will fit the entire circumference of the cylinder perfectly when the ends are just about in contact with each other. The grooves in the piston are cut deep enough so that when the rings are placed in them they are just filled, so that the spring of the rings outward is sufficient, when they, with the piston, are put into the cylinder to sweep the entire inner circumference of the cylinder. This provides for the taking up of the small difference between the diameters of the piston and cylinder. The piston necessarily has to be made from 1-60 to 1-120 of an inch smaller in its diameter than the cylinder in which it is to operate. This difference in diameter is sufficient, were it not for the rings, to allow the escape of practically all of the expansive force without producing any power. Both the outer circumference and sides or edges of

the rings should be ground to true surfaces as well as the sides or edges of the grooves in the piston so that the rings will fit in these grooves perfectly. A loose-fitting ring in its groove will allow the expansive pressure to get under it and escape in that way. Assuming that the manufacturers all make their pistons, rings and cylinders perfect it is necessary to give them a certain amount of care to keep them in good working order. The kind of oil used for lubricating the piston is very important. It should be closely watched to see that it does not gum up the rings. If it does, change oil till you get the right kind. If smoke comes out of the open end of the cylinder at each impulse it is evidence that there is something wrong about the piston. The oil used has probably gummed the rings so that they are stuck tight in the grooves and cannot perform their part as they should.

Any one having the care of an engine should study the manner of oiling the piston until he is able to set the lubricator so that it will do the work just right. A lubricator may work nicely on a warm day, but will not work at all on a frosty morning unless readjusted. A high temperature has a tendency to thin the oil and a low temperature thickens it. The lubricator must be adjusted to suit the condition of the oil. An over supply of oil leaves a surplus in the cylinder which is forced up into the compression space or end of the cylinder and there is burnt into carbon particles which deposit upon each other until they become a source of annoyance. They also collect under the rings at the bottom of the grooves until they interfere with the free action of the rings. The piston should be removed from the cylinder and thoroughly cleaned by prying the rings out of their grooves and cleaning out all the accumulated carbon. The rings will spread enough if carefully handled to be slipped off over the piston. This is the way they are put on and removed, by springing them until they slip over the outside diameter of the piston. By learning how to lubricate the piston properly and by cleaning it whenever necessary, and keeping the cross-head bearing in proper adjustment the operator will learn the importance of the piston in the gas engine.—*Canadian Implement and Vehicle Trade.*

A GASOLINE ENGINE REPAIR JOB

A hurry call over the phone at about quitting time: "Mr. —, is that you?" "Yes; what can we do for you?"

"Why, we can't get our engine to run, and we have a big carload of ice to unload tonight; can you send a first-class man out at once?"

"Why, yes; we will start a man right away. Is anything broken that you know of?"

"No; we just can't start her up at all. Hurry up your man, please."

Well, the machinist most familiar with gasoline engines was sent post-haste to the scene of trouble. It was an hour's ride on the trolley and then quite a walk to the engine. The next morning the following conversation between the above-mentioned machinist and the superintendent who took the 'phone order will disclose the difficulty with the engine:

Superintendent: "Well, John, what was the matter with their engine last night?"

John: "They needed some dry matches."

Superintendent: "What?"

John: "Yes, that is right; you know that it is a self-starting machine and is started by means of a hand pump located on the side of the cylinder. To start the engine you first prime the starter with gasoline and place a parlor match in a holder, then pump until there is pressure enough to start the piston; a blow on the holder lights the match, which ignites the gas, and away she goes. The electric spark taking care of the rest. Well, when I got out there I found that the gasoline supply was all right; that the sparker gave a good spark; and so the engineer in charge attempted to start her up. She refused to move, and I noticed that the match had apparently not lighted; so I put in one out of my matchbox and she started right up. The matches he had out there were damp and he hadn't noticed them.

The above is a true account of an incident in one of the repair shops of Georgia and illustrates the importance of looking for small things rather than great defects in the gasoline engine which won't run.—
The Practical Machinist.

THE IMPLEMENT DEALER AND THE GASOLINE ENGINE

The question of help, whether human or mechanical, is one of the most important factors in modern agriculture. Without sufficient assistance it is impossible for the farmer to carry on his work in the most thorough manner. This is particularly true of Western Canada, where the average farm is so much larger than elsewhere in the agricultural world. In view of this, any invention tending to a successful solution of the labor problem is of vital interest to the progressive agricultural community, and when such a device takes the form of a farm implement the dealer is immediately interested.

Among appliances for labor saving on the farm none has come more rapidly to the fore than the gasoline engine. Having passed the experimental stage, and the danger of explosion and unsatisfactory work being eliminated, this engine is recognized as an agricultural necessity. There is no section anywhere, throughout the

agricultural area of this country, but it is possible for the dealer to place a number of gasoline engines, as soon as their merits are pointed out and demonstrated.

A large portion of the work of the farm is in attending to the chores; such as pumping water for the stock, sawing wood, grinding feed, cutting fodder, operating the churn and cream separator, and many other things for which the gasoline engine is eminently suited. Many of these operations require the work of two persons when hand or tread power is used, whereas if an engine was employed the work could be completed by one person in a fraction of the time and in a more thorough manner.

There is no one who has a better chance of placing the benefits of the gasoline engine before the farmer than the implement dealer. He sells practically all the other machinery purchased by the farmer, and is continually coming in contact with him. The dealers, however, in very many cases

have been negligent of the advantages to be derived from the use of this machine and have not given it the attention they ought. In some cases the farmer has purchased a gasoline engine direct from the manufacturer, but even this fact has frequently failed to awaken the dealer from his lethargic condition, and he has continued to neglect the sale of this labor and time-saving appliance.

The implement dealer should invest in a gasoline engine and set it up in his warehouses. Here he can demonstrate to every visiting customer the benefits of such a machine. In this way the farmer's attention

is attracted and a number of sales will undoubtedly result. There is no machine offered to the farmer capable of performing such a multiplicity of tasks. There is none ever more ready for service. If the gasoline engine is kept in good repair, it is always ready to commence work, and it costs nothing to keep while not in use. For the dealer there is good profit in every sale, and as these engines are growing more and more in public favor it behooves every implement dealer in Western Canada to become the handler of a high-class gasoline engine.—*Canadian Farm Implements.*

THE EXCELSIOR SPARK PLUG.

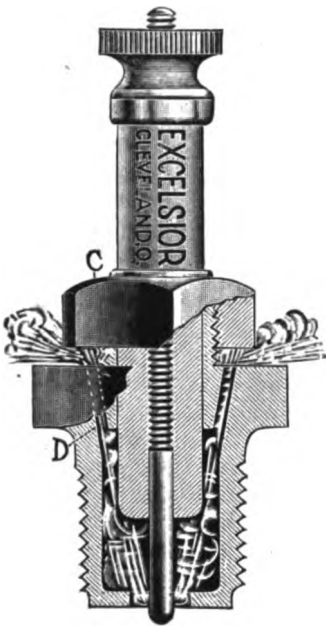

A spark plug that has some entirely new features of interest is now being manufactured by the Excelsior Spark Plug Co., of Cleveland, O. It is particularly interesting on account of the manner in which it can be instantly cleaned of soot deposit while hot and without stopping the engine or disconnecting the wiring, this peculiarity having caused the makers to name it the Excelsior "easy clean" spark plug. They state that notwithstanding how much a plug is protected against soot, if there is an im-

proper mixture fouling is certain to occur sooner or later, and when this occurs with the "Excelsior" it can be cleaned in an instant in the following manner. Referring to the accompanying illustration, several openings (D) extend from the inner part of the shell through the steel of the hexagon portion and terminate under the upper hexagon nut or collar (C), on the under surface of which is affixed a solid copper washer. This nut or collar (C) is ordinarily jammed down tight on the copper washer, effectually closing the openings (D), which have but a small area, and thus sealing the plug, but when it is desired to clean the plug the collar or nut (C) is loosened with a wrench while the engine is running, thus unsealing the openings (D), and the hot gases on compression and explosion are driven very violently through the plug. The scouring action thus set up is claimed to quickly render the inside of the plug as "clean as a whistle," after which the collar (C) is turned down tight, sealing the plug.

It is stated that the natural stone insulation which is used is subjected to a new process of treatment, being "filled" with a fire-proof composition under high pressure, filling the pores and rendering it non-absorbent. The makers also claim that, owing to the peculiar shape of the center electrode, it drains oil away from the sparking surfaces. In addition to its "easy clean" feature, the plug readily adapts itself to the purpose of a com-

pression relief cock, and should also prove convenient for removing condensation of moisture, which sometimes short-circuits plugs in large engines.

The Excelsior Spark Plug Company is prepared to manufacture on a large scale, and its product would seem a promising ing industries.

TRADE PUBLICATIONS.

The Spark Plug Hat, a cover for spark plugs, is the subject of a circular from C. H. Stuart, Newark, N. J.

A catalogue of the Bates & Edmonds Motor Company, Lansing, Mich., shows the various types of these engines, from $1\frac{1}{2}$ to 10 H. P.

The catalogue of the Hildreth Motor and Pump Co., Lansing, Mich., shows the $1\frac{1}{2}$ to 24 H. P. vertical engines in the actual colors of the finished product.

Several styles of engines up to 30 H. P. are shown in the catalogue of the Peerless Motor Company, Lansing, Mich. A number of the engines are shown in colors.

The Burnett Foundry and Machine Works, Ltd., 314 State street, Petoskey, Mich., are sending out a circular of their marine and stationary engines.

The "Vreeland" gas engine, built by Kumberber & Vreeland, 35 Sullivan street, New York, is described in a folder received from the manufacturers of this engine. Both stationary and marine types are built.

The K. Lambert Gas and Gasoline Engine Company, Anderson, Ind., has just issued a new circular showing the "Lambert" engines. Quite a number of special advantages in the use of the Lambert are given.

The M. O. Cross Engine Company, Detroit, Mich., is making a specialty of a four-cycle marine engine, and has issued a circular showing the various sizes, from $1\frac{1}{2}$ to 50 H. P., in single and multi-cylinder types.

Circulars being mailed by the Beilfuss Motor Company, Lansing, Mich., show an 8 H. P. horizontal automobile engine, a 16 H. P. double opposed and a vertical stationary engine built in units from $2\frac{1}{2}$ to 7 H. P.

An improved "Duplex" gas engine has been brought out by The Flickinger Iron

Works, Inc., Bradford, Pa. The engines are shown in a circular, which the company is sending out, and they are built in units from 75 H. P. up.

The Robert combination volt-ammeter is a very useful device for ascertaining the condition of ignition batteries, and its merits are told in the catalogue of the Robert Instrument Company, 56 Shelby Street, Detroit, Mich.

The catalogue of the DuBrie Motor Company, 34 Brush Street, Detroit, Mich., shows two and four-cycle marine engines, from 2 H. P. up. This company also builds a stationary engine of 4 H. P., as well as other units.

A catalogue from the Automatic Gas Producer Company, 25 Broad Street, New York, N. Y., shows a new producer, in units from 25 to 400 H. P., and suitable for bituminous coal and other products, as well as anthracite coal.

Catalogue "C," of The Raser Gas Engine Works, Ashtabula, O., covers their engines, which are described as "Good engines only." A feature of these engines appears to be the use of three valves, one each for gas, air and exhaust, instead of two which are customary. Units from 4 to 30 H. P. are catalogued.

"The largest air-cooled motor made," is the claim of the Air-Cooled Motor Company, Lansing, Mich., in their circular. The 5 H.P. engine, 6 in. stroke by 6 in. bore, is cooled by ribs and a blast of air from a small fan which is located at one side of the cylinder. Units as small as $1\frac{1}{2}$ H. P. are made.

The Kneeland Manufacturing Company, Lansing, Mich., evidently believe in illustrating their engines just as they are, and in a catalogue issued by them there are two excellent halftones in three colors, showing the engines as they are actually painted and finished. A specialty

is made of a 6 H. P. vertical engine, which is described as running "with clock-like accuracy."

The Goodson Electric Ignition Company, Providence, R. I., has issued a new circular of their spark coils. The number of layers of wire, weight of wire, resistance, dimensions and weights of the various styles of coils are given. This company is prepared to manufacture special coils, and can turn out large orders promptly. They also carry

in stock a large quantity of insulated wire for gas engine use.

We have received from the Office of Experiment Stations, U. S. Department of Agriculture, a booklet entitled "Free Alcohol for Industrial Purposes." In the main it presents the arguments for the lowering of the Government tax on alcohol from the standpoint of the gas engine, and shows the advantages to be secured by tax free alcohol.

INDUSTRIAL ITEMS.

As mentioned in our last issue, the Dean-Waterman Company, Covington, Ky., has removed to Newport, Ky. The name of the company has been changed to the Dean Gas Engine and Foundry Company, and the new location is at the corner of Front and Washington streets. The building is one formerly occupied by the Addyston Cast Iron Pipe and Foundry Company, and overlooks the Ohio River, directly across from the Pennsylvania Railroad Station at Cincinnati. The capital stock of the company has been increased to \$50,000, fully paid in.

The foundry floor space exceeds 45,000 square feet, and there will be increased facilities for furnishing all kinds of light and heavy gray iron castings. Several new sizes have been added to the line of Dean stationary gas and gasoline engines, and a line of marine engines will also be put on the market. The location on the river gives the company excellent facilities for testing this type of engine.

The Continental Engine Company are now definitely located at their new shops, corner Kingsbury and Huron streets, Chicago. They have purchased a special engine crank case and transmission gear case, joint milling machine and a Brown & Sharpe cylinder grinder and finisher, and also a cylinder boring machine, and are now enabled to satisfy customers in the larger sizes of engines. A specialty is made of the $4\frac{3}{8} \times 4\frac{5}{8}$ twin-cylinder engine in 2, 4 and 6 cylinder units, and the exclusive manufacture of a four-cycle valveless engine. Marine engines of various sizes have been continued, and are supplied in the various horse-powers that they have before. New types for 1906 have been brought out, and

the models and sample machines have been brought through.

In the transmission department new designs have been developed. The gears are all cut on automatic gear machinery, and all the gears are, as previously, steel forged and hardened after machining.

The contract and designing departments for assemblers and manufacturers wishing special manufacture or work of this nature, is made a specialty, and they are now prepared better than ever to carefully take care of this outside special work.

The New York Motor Club will conduct its First National Economy Test the week of October 30th. Ten entries are in hand, the list including two Reo and one Frayer-Miller car. The test committee has issued rules for the contest. They show changes in the regulations, including drastic provisions against speeding, the allotment of oil and fuel changes on a basis of the schedule appointed by the New York Automobile Trade Association, and other points.

The American Coil Company has removed from West Somerville, Mass., to Foxboro, Mass. They have taken over the business of the Sherman Mfg. Co., of Boston, and will have increased facilities for handling orders in their line, which includes induction coils, ignition dynamos, spark plugs, mixing valves and other electrical specialties.

The Bruce-Meriam-Abbott Company, 8-12 Columbus street, Cleveland, O., report that they have been enjoying a very good business in the gas engine line. They have

recently secured orders for a 100 H. P. engine to be installed by the E. R. Thomas Motor Company, Buffalo; also two 35 H. P. engines direct connected to two 20 k.w. generators to be used for a lighting plant by the T. & E. Dickinson Company, jewelers, of the same city. They recently shipped to Chicago two 27 H. P. units to be used for lighting purposes, and have sold recently for lighting purposes in Cleveland and vicinity four 50 H. P. engines and a number of smaller engines. A large clothing house at New Castle, Pa., is installing a 50 H. P. unit to be used for lighting. This company is now building engines from 8 to 125 H. P. of the vertical twin cylinder type, especially adapted for electric lighting service.

Messrs. Herz & Co., 187 Elm street, New York City, have brought out an ignition cable covered with several layers of rubber alternating with a secret compound. The whole is protected by a steel armor, which, however, does not interfere with the flexibility of the wire. The outer steel cable is brought into conducting connection with the ground, and the use of the cable is said to increase the efficiency of the spark. It

is sold ready for connection to the engine.

The management of the Ohio River & Western Railroad announces that it will broad gauge its road between Bellaire and Elden, O., by laying a third rail, and that it will run gasoline motor cars over that part of the line for passenger traffic. This is an experimental scheme, which, if found successful, will be put in operation on the whole line between Bellaire and Zanesville. The road is a narrow gauge, with heavy grades, and its owners have long been considering a plan of converting it into a gasoline motor driven interurban.

The Tritt Electric Company have recently moved from South Bend, Ind., to Union City, Ind. They have secured a much larger building and have larger facilities than before. The company manufactures everything which has to do with the ignition end of the gas engine industry, whether the gas engine is used for automobiles, boats or stationary work. The building now occupied was formerly occupied by the Union Automobile Company, which has moved to Anderson, Ind. This building was built especially for their use, and is very commodious and well equipped throughout.

SOME GAS ENGINE SALES.

An increasing demand for the gas engine is noticeable, due no doubt to greater appreciation of the excellent operating economy of this class of prime mover. The Westinghouse Machine Company, of East Pittsburg, Pa., report that they have received within the last few weeks many orders for gas engines, ranging from 10 to 1,000 B. H. P. No less than thirty-six gas engines are covered by these orders, aggregating 6,647 B. H. P.

One of the most recent and significant orders was received from the Rockland Electric Company, of Hillburn, N. Y., for two 500 H. P. double acting horizontal tandem gas engines. This company has already in operation three 19 x 24 - inch Westinghouse double acting gas engines direct connected to generators, and this second order serves as a testimonial of their satisfaction with the use of gas engines as prime movers.

Another order worthy of special men-

tion is one from the Union Traction Co. of Kansas, Independence, Kan., for one 500 H. P. horizontal tandem gas engine and one 1,000 H. P. horizontal twin tandem gas engine, both for A. C. generator driving in parallel. Other orders were received from the Sherwin-Williams Company, Newark, N. J.; American Sheet and Tin Plate Company, Pittsburg, Pa.; The Sidney Electric Light Company, Sidney, Ohio; J. C. Sterns Electrical Company, Buffalo, N. Y.; American Snuff Company, New York City; Northwestern Lithographing Company, Milwaukee, Wis.; Granite City Hospital, Granite City, Ill.; American Locomotive Works, Allegheny, Pa.; American Acid & Alkali Company, Bradford, Pa.; Amolyo Mining Company, New York City; Home Light, Heat and Power Company, Pittsburg, Kan.; City Hall, Pittsburg, Pa.; Dr. C. F. Bingham, Pittsburg, Pa.; Automatic Electric Company, Chicago, Ill.

THE GAS ENGINE.

STATIONARY—AUTOMOBILE—MARINE.

PUBLISHED MONTHLY BY

The Gas Engine Publishing Co.

Blymyer Building, Cincinnati, Ohio.

ADVERTISING RATES ON APPLICATION. Address All Communications to the Company.

Entered at the Postoffice at Cincinnati, Ohio, as Second Class Matter Feb. 20, 1899.

VOL. VII

DECEMBER, 1905.

No. 12.

Domestic Subscriptions, \$1.00 per Annum.

Single Copies, 10 cents.

Foreign, \$1.50 per Annum.

It is said that nearly 1,000 H. P. of gas engines have been installed in New Jersey this year.

The city of Winnipeg, Manitoba, is about to install a 2,500 B. H. P. gas producer plant for fire service water works.

We have received No. 1, Vol. 1, of *Gas and Oil Power*, a new English monthly devoted to the gas engine industry. We extend to our British contemporary our good wishes in its efforts to extend knowledge of the gas engine.

"Carbonaceously omnivorous" is the epithet applied to one of the types of gas producers by its manufacturers. The meaning is that it will "feed alike, without change of construction, upon anthracite and semi-anthracite coals and culms, upon all vegetable and animal matter, upon lignite, semi-bituminous, bituminous and cannel coals."

The narrow escape from disaster of the man who unexpectedly found himself in a power boat, the engineer of which had suddenly dropped dead, and who did not know how to stop the engine, offers food for thought to many people. A little knowledge of a gasoline engine under such circumstances would not prove a dangerous thing.

The government at Madras recently installed twelve oil engines for driving irrigation pumps, and reports state that good success has been the result. Soon after their installation thirteen poor farmers sent in applications for engines and pumps to be erected on their property by means of loans granted under a land improvement loans act.

In the "Want" columns this month will be found several advertisements for foremen of gas engine shops. Here is an opportunity

for several good men. If you are competent to fill any of these positions and do not care to answer any of these advertisements unless you know who the advertisers are, write to the editor, giving full information as to your abilities. He will be governed accordingly and will see that your identity is not made known to other than desirable persons. We know that many good mechanics hesitate to answer "blind" advertisements for fear their letters will go to their present employers, and for this reason we make the above suggestion.

"A gasoline engine never stops of its own accord without a good reason for it," is the statement of a writer in another column. It would be well for every user of an engine to bear this in mind. If an engine has been running for several hours and then stops, there must be some good reason for it, and it is "up to the operator to find the cause." Similarly, if an engine has run without difficulty one day, there is no good reason why it will not do so the next day, unless conditions have been changed. It is therefore foolish to spend hour after hour, as has been done by some "unreasoning" gas engine operators, in turning the engine over and over to try to start it. If the engine does not start on the first two attempts it is time to look around and find out why it does not start. There must be some good reason.

The expansive action of a rod under heat has long been used as an automatic attachment for mechanical operations. In incubators such an arrangement regulates the valves according to the temperature of the egg chamber, maintaining an even degree of heat. It is proposed to use such action to vary the proportion of gas and air in a gas engine according to the calorific value of the gas. A flame heats a metal rod, which, by its expansion or contraction, regulates the valves.

PRICE VS. QUALITY.

BY A. A. ANDREWS.

"No, sir, I can't handle your engine any more; we sold it for some time to good advantage and it gave good satisfaction. But we have an engine now which sells for so much less money that we have been handling it for several months. Of course, it is not built so well as yours, perhaps, and it is not finished so well; but it sells, and those that have been placed seem to do the work all right. How long they will last I don't know, but they have all lasted long enough for us to get our money, and that's the essential thing."

These are the actual words of a local dealer to a gas engine manufacturer who had called on him to ascertain why his business in the gas engine line was going elsewhere. By way of completing his statements, he said that he could buy a 6 H.P. portable engine for a certain amount which would astound most persons acquainted with the prices of engines, and he proved his statement of the price by showing the bill.

But the question is, is it even then a profitable investment for the dealer? Is the main thing, after all, to get the money? On the other hand, isn't it the main thing to so conduct one's business that every customer will prove a satisfied one, will advertise his engine and do all he can to help make additional sales? About the worst situation the writer can conceive for a dealer is to be deathly afraid that a prospective customer will learn where the dealer has sold engines in the past and the purchasers are dissatisfied.

But, getting back to the question of the price, the dealer, of course, finds much in his favor when he is able to make a price lower than most of his competitors. On the other hand, is lowest price necessary to make a sale? Does not quality count for something? What makes the difference between the low-priced engine—the low-grade engine—and the more reasonable and higher-grade engine?

In the first place, salesmen make statements which are subject to criticism. For instance, the writer once knew of a salesman who said of a competitor's engine: "Why, those people used old, second-hand iron in their cylinders. You can go down

to their foundry any time and see them dumping old broken scraps of iron into their cupalo." And he told me that it was surprising how few people know that scrap iron in more or less quantity was used by practically every foundry in the country in making gray iron castings, and that it had no bad effect.

But, coming to some of the real causes for difference in quality of engines, we might mention, first, the quality of the materials used in the construction of the engine itself. While iron may be iron, there is, as every manufacturer knows, quite a difference in cylinder castings. A good, smooth-grained cylinder casting, and a piston with like qualities, will not lose compression as soon as will an engine with a soft cylinder. When one figures that even for a small-sized engine the cost of rebor-ing the cylinder and fitting a new piston amounts to a goodly item, he will begin to investigate the quality of the iron used for cylinder and piston castings.

Many engine manufacturers claim that babbitt can not be used successfully for the main bearings of gas engines, but the writer has seen many babbitted bearings last so long in gas engines that he feels safe in saying it is a question of the quality of the babbitt. Other manufacturers bewail the disadvantages of brass and phosphor bronze bearings, and can truthfully point out instances of their short existence. These too, where not occasioned by negligence, may often be attributed to poor material, for there are many instances of this class of bearing giving long life and satisfactory results.

Outside of the quality of the engine proper, there is the quality of the fittings and accessories. One engine in a certain section of the country is, so the writer is told, always referred to as "that engine with a good tank." The quality of the water tank seems to have surpassed the quality of the engine to such an extent as to have left the latter in a doubtful situation.

There is, of course, much difference in the quality of lubricating cups, oilers, etc. A good sight feed cylinder lubricator often costs several dollars, and a full line of first-class lubricating devices will vary much in

price, according to the style of oilers used. The same thing applies to batteries, or magnetos and ignition dynamos where supplied.

After quality of materials comes quality of workmanship. Poor mechanics can not turn out good engines, even if constructed of good materials. Poor machinists result in poor compression, imperfect fitting of the parts, poor adjustment, etc. Under this same head might be considered the quality of the design of an engine. One manufacturer greatly improved the design of his engine several years ago when he put small oilers on the valve cages to lubricate the valve stems.

Now, what are some of the results of poor workmanship and material? The engine easily gets out of adjustment, either by parts loosening or wearing. The compression leaks. The bearings get hot and the valves warp and fail to seat properly. Perhaps the fly-wheel gets loose and breaks the crank shaft. Repair parts are needed frequently, also renewals for batteries. The operator spends perhaps as much time try-

ing to keep the engine in repair as he does in giving it legitimate care.

It is costly to operate such an engine, both from the standpoint of the repairs and from the point of the amount of fuel, lubricating oil, etc., used.

Five years ago an engine was installed in a certain factory at a cost of about \$685. Today the engine happens to be on the market, and the owner is asking about \$400 for it, and he will get it. The engine is a bargain at the price. It is a first-class engine and has had first-class care.

Is it, after all, profitable for one to handle or to buy a "cheap engine?" In the machinery line as nowhere else in the machinery line does quality count. Cheap engines result disastrously for all who have dealings with them.

This article has been written because the writer has had impressed on his mind some results of cheap engines, and he feels that a few words of caution should be spoken on the points of "Price vs. Quality."

TAKE CARE OF YOUR ENGINE!

Under the heading, "Provide Shelter for Machinery," a writer in one of the farm journals recently said:

"It is time that we open our eyes and take care of the tools for which we have to pay the hard-earned cash. It has been estimated that more machinery is worn out by the weather and not being sheltered than is worn out by actual use, and I believe this estimate to be not far from correct. This is a good way to keep the manufacturers rich, and it is keeping more farmers poor.

"It will pay to build a shed just for the purpose. It will be an investment that you will never regret, for you will find it to be one of the most profitable investments that you ever made. One man has figured it out, and in the course of ten years, after counting the cost of the shed and the interest on the money and all the expenses to shelter the tools, he finds that he has saved and made over \$500.

"It is not only the rotting of the tools, but in the shape in which the tools are in the spring after having taken the weather all winter. Just imagine a plow which was

run in the fence corner as soon as the last furrow was plowed, and remained there until hitched to next spring, all rusted. The owner will have to work and worry half a day to get it in shape to do good work. This is only a fair example of the thousands of plows and other more valuable implements which spend the winter season in such places.

"Then take a plow owned by the other kind of a farmer, and note the difference. As soon as this man turns the last furrow the plow is taken to the shed and put under cover and given a good coat of grease. There it remains in the dry, and protected from all kinds of weather, until needed next spring. But the difference is that when this man takes his plow out in the spring he wastes no time, but the plow is in working order, and he begins work at once. And does not this pay?

"But don't you think that plows and other implements which directly till the soil are the only ones, but just think of a binder standing out and taking the weather for the winter and for the rest of the year, for the use of it for a couple of weeks.

"I know a man who used a mowing machine for fifteen years, and did cutting regularly, and I know another man who wore out three in the same time, and he did no more cutting than the first. There is a lot of difference in the care of a machine while using, as oiling, etc., which may have made some difference; but I know where a great difference was. The first would shelter his machine the best he could, and the other would run his machine under a tree until the next season (probably because his fence corner was full of worn-out tools). Which paid?"

There is much in these remarks which could be taken to heart by gas engine users. How many times the writer has felt warm under the collar on coming onto an engine which had been worn out simply through exposure. And every one who has had occasion to see many gas engines in use has found this condition to exist.

The writer remembers an engine which was placed in an open shed exposed to the weather. Chickens roosted on it, and I doubt if the engine could have been started inside of several hours, and until it had been cleaned up and the rust and dirt eradicated.

Almost any gas engine "trouble man" can relate instances when before attempting to start an engine (which had been reported as giving trouble) he has spent an hour or two in cleaning it up. One man, on arriving at an engine said to the owner: "Do you want me to clean up that engine? I'll do it, if you want me to, but the firm will charge you 60 cents an hour for my time, and you might as well have your porter do it and save some money."

Farm engines are most likely to be exposed to the elements and as they are often idle for several days or perhaps weeks, at a time in the winter, they often get in very bad shape, rusting from exposure. But in factories and shops when engines are used for power service, engines are also often neglected. It is not often that in such cases they are exposed to the rain and snow, but they are exposed to dirt and dust which, together with the surplus grease, works havoc with the engine. They are allowed to freeze, to run without water till they stop, to go without oil, and to run out of adjustment until something breaks. Such cases are purely carelessness or ignorance and are inexcusable as well as costly to the owners of the engines.

CORRESPONDENCE.

EDITOR THE GAS ENGINE:

I have placed quite a few gasoline pumping engines in coal mines in this section and have also repaired a great many, but had a strange accident happen me the other day. I had placed a pumping outfit in a coal mine and after a few days went into the mine to see how those in charge were getting along. On arriving at the pump, which is about one mile under ground, the mine boss told me that the engine was all right, but they had trouble in getting the pump to take its water. After looking the engine over a little I started it, then threw in the clutch starting the pump, but got no water, so I then began looking for the trouble. Finding no air leaks I released the clutch and examined the valves to see if they seated properly, but finding nothing I primed the pump and started it, again getting no water. I examined all joints, etc., for air leaks, but found none, so I stopped it again to make a more thorough investigation. As the suc-

tion and discharge were clear and there was good packing and the valves seated themselves perfectly, I could find nothing to interfere, so I primed it again and stated it, but got no water.

I then intended trying it once more, and as I removed the caps of valve chamber I placed my torch over the opening to look into it, when a deafening explosion took place. It lasted several seconds and was followed by smaller explosions. After these had died away I raised up, having lain down to avoid flame and heat. I found my lamp, which had been blown out of my hand, lit and found that everybody had gone. The valves, etc., were all blown out of the pump. Up until this time I have been unable to give myself a very satisfactory reason for this.

I at first thought probably some one had by mistake primed the pump with gasoline, but this could not be, as the pump was working two hours before and there was

no gasoline in the mine except that placed in the tank by myself and it was still there, and there was no way to get at it without disconnecting. There were no gasoline leaks and it was 200 feet to the water with about five-foot drop, and the track was dusty. The water being pumped was fresh, and there is no gas in these mines, as a current of air moves all the time, so it could not be that. If any one had placed gasoline on the water it could not have reached the suction pipe, as it was fifteen feet under water. The explosion seemed to have great volume, lasting too long for gasoline or gas in so small a space, and seemed to have a perfect combustion at the start and was fed by air or oxygen at intervals as the work-

ing would cease. Judging from the power of such an explosion I think that if these gases had been compressed and ignited the walls of the pump would have never stood it and I would have done well to have followed the others. The only thing that kept me from being burnt was that I was used to keeping my face away from openings in gas engines when making an examination with a lighted torch; there was no heat created in the pump from friction, as plenty of water was used. Very truly,

H. O. EWING.

Pomeroy, O., November 8, 1905.

[We should be pleased to hear from any of our readers who have an explanation to offer regarding the above.]

OIL AND GASOLINE ENGINES ABROAD.

Every year sees an increase in the use of gasoline and oil engines in various parts of the world. This is particularly noticeable in Sweden, South Africa, Russia, China and Palestine. In Sweden their use has increased very considerably, and interest and confidence in them are steadily growing. It is quite clear that there is a wide field for such motors, especially where small power is needed. Among gas engines the suction gas variety appears to take the first place, and is generally used in sizes up to about 100 H. P. They are usually employed in factories and for electric power stations and for boats. They are invariably of the four-cycle type. Up to the present, English and German makers have supplied most of those in use. Gasoline motors are generally of small sizes, such as 3, 5 or 7 H. P., and rarely exceeding 40 H.P. Most of those to be seen in Sweden today have been sent from the United States. They, likewise, are of the four-cycle pattern, and are principally used in motor cars, boats, etc. Oil engines range from 1 to 200 H. P. There are decided indications that their use will be very extensive, especially as regards fishing boats, smaller freight craft, etc. Up to the present most of the oil engines in use are of native manufacture, many leading Swedish engineering firms having devoted themselves exclusively to their production. These engines are very easily understood by non-technical people, and are of the two-cycle type. They are very much

in favor among farmers and small industrial concerns.

China offers another capital opening for the sale of gasoline and oil engines, as the number of mills with fair-grade power plants is increasing. There will probably be a market in China for such manufactures in excess of anything we can at present conceive. Such engines can be put on the market at a reasonable rate, and are strong and simple enough to meet the requirements of a country where there is an absolute lack of knowledge of such machinery and its practical operation. What is particularly wanted in China is to give practical demonstrations as object lessons showing just what these engines will do. Ocular proof of what a machine can do is what pleases the native best and tends to lead to immediate business. A leading firm in Shanghai some months ago established a show room in which types of machinery were set up, with a small engine to drive them if a customer wishes to "see the wheels go around." The results are reported to be beyond expectation, and it is certainly an example well worth following.

In South Africa the demand for oil engines is increasing in mining districts away from the Rand and distant from coal fields. Such engines are used for working batteries, and are particularly wanted. Wood fuel is out of the question in such districts, because the outlay on labor and plant alone to procure wood fuel for a small mine is

estimated to amount to between \$750 and \$1,000 a month. Dependent on wood, development of many mining properties becomes quite impracticable, whereas with an oil engine the solution is easy. Apart from the mining industry, the development of South Africa depends upon agriculture, and that, in its turn, depends upon an efficient system of water supply. There is a great demand there for pumps and wind mills, and the sinking of wells is a pronounced necessity. The government is realizing every day the necessity for boring for water as much as possible, and it is offering drills at low hire to farmers. As in most cases the water, when found, does not run out, and can not be furrowed out, it is necessary to use a deep well pump, with either steam, oil, gas or wind power.

Russia offers another market for relatively small motive power engines, both gasoline and oil. There is particularly a chance for small-sized stationary engines, traction

motors, etc., using denatured spirit as fuel. Nearly every fair-sized estate owns its own distillery, and as the production of rye spirit is not costly, it is very probable that the land owners and farmers will be anxious to make use of spirit as fuel to work their farm machines, to illuminate their houses and for transporting their crops. I believe that up to the present only one small-sized stationary motor has been imported into the Kieff district of Russia, but that one has proved eminently successful. The subject is well worth the attention of American makers of small engines, as there is no doubt whatever that a serviceable sized spirit-driven motor powerful enough to work ordinary grinding mills, small thrashing machines, chaff cutters, etc., would find a quick sale. There are also the small-sized tractors for plowing and reaping machines, further opening up a field quite untouched at the present time in Russia.—*Farm and Implement News.*

GAS VS. GASOLINE ENGINES.

At a meeting of the Iowa Gas Association, Mr. L. F. Blyler read a paper on "The Installation and Use of Gas Appliances." In referring to gas engines he stated that the average yearly consumption of gas by engines was 60,000 cubic feet per actual working H. P. This would be at the rate of 20 cubic feet per hour, 300 days of 10 hours per year. In answer to the question at what price gas would have to be sold for a gas engine to compete with a gasoline engine, with gasoline selling at 14 cents a gallon, Mr. Blyler said: "We have had about a dozen instances in Des Moines where we induced people using gasoline engines to take them out when the price of gas ran all the way from \$1.30 down to our present rate of \$1.10 or \$1 the first of next year. We had one very good instance where they had purchased a cheap gasoline engine and ran it about seven months, when we proposed to them that they allow us to take the engine from the foundation and set it to one side and place a high-class gas engine on the foundation; we proposed to run it a month, with the understanding that we would reset their gasoline engine and take ours away after the demonstra-

tion. The installation was made and the engine reduced their bills from \$12 to \$8; \$12 was the gasoline bill and \$8 the bill for gas at \$1.15, and I think their gasoline cost about 13 cents per gallon. We let it run one month, then another month, and the third month we went to them and told them we would like to have the engine, that we had a customer for it, and they said that the engine would never come off that foundation, as we were saving them money. They then told them that we had taken a high-class gas engine to compare with their low-grade gasoline engine, but that same engine is there today. In every instance where we have made changes—and I think we have about 4,500 gas engines running in Des Moines—it has been entirely satisfactory; but you must get a high-grade gas engine, and those engines cost money. Use the hit-and-miss type of gas engines if you want to demonstrate economy. I had occasion to make tests of the throttle type of engine in Chicago about a month ago, running on a varied load from 8 to 30 H.P. The 8 H.P. engine ran on 60 feet of gas per actual H.P., but on the full load it ran about 24 cubic feet of gas on what they

claim to 450 heat unit gas. Reducing to 650 B.T.U. gas makes it 20 or 21 cubic feet."

Another speaker said: "Taking an equivalent of 5 gallons of gasoline to 5,000 cubic feet of city gas, and taking 0.1 of a gallon of gasoline per H.P. makes the cost of gasoline about 7 cents, but I think it is a fact that gasoline is wasted very largely in using it in a gasoline engine. It evaporates quickly, the insurance rates are higher and, taking everything into account, I do not doubt but that the gas engine can be introduced on \$1 to \$1.25 gas."

Mr. Blyler also answered the question, "How many electric motors are put out of business by the use of the gas engine?" by saying: "The electric current rate in Des Moines is 7 cent per kw., and we can make electric current for about 3.75 cents, but unless electric companies begin to reduce the price of their current to conform with the price of gas, we would have a very good chance of going after electrical business. I think last month we displaced about four electric motors in Des Moines. Theoretically, gasoline is cheaper than gas, but practically gas is the cheaper. Considering the handling of the gasoline, evaporation and insurance, I think it does not make a difference of more than 0.2 cent in the cost of the gas and gasoline for gas engines. The action of the engines being very much the same, an engine would adjust itself auto-

matically almost as carefully when using gasoline as with gas. The gasoline should be of at least 72 gravity; with 68 they have trouble. Gasoline behaves differently in winter from what it does in summer, and they can not get the same results as they can with a uniform quality of gas."

Continuing, Mr. Blyler said: "We installed a 16 H.P. White & Middleton horizontal gas engine of the hit-and-miss type to drive an electric plant. It runs a 160-light machine that is belted to the shaft and on it a balance wheel that weighed about 250 pounds; that was belted back to the dynamo, and the quality of lights that they got from that engine is almost all that could be expected. A study of the lamp showed slight fluctuations, and this was accomplished by using two belts and balance wheel. I want to say that the inducement offered is considerably more than we make for a stove. I think that an engine that we are converting from gasoline to gas will cost the gas company in the neighborhood of \$20 for the attachment to convert the engine, and the engine will use from \$45 to \$55 worth of gas per month, so that we will not have to wait a year to get our money back; wherever there is an opportunity to put in a hotel range or a gas engine, or anything that is going to bring in from \$75 to \$150, I think that very liberal inducements should be made."

NOTES FROM ENGLAND. ON. GAS POWER.

In a paper read by E. A. Dowson before the Birmingham Association of Mechanical Engineers, the author pointed out that in all large gas engines the greatest troubles experienced were those due to the high flame temperatures in the cylinders. Rapid cooling of the charge is necessary to protect the working parts, and the metal of the combustion chamber and cylinder must be left as free to expand as possible. Valveless engines such as the Oechelhaeuser have an advantage in this respect. Continental makers of large engines have resorted to complicated systems of water-cooling for the pistons and rods in double-acting engines, as well as the exhaust valves and their casings, and of course the cylinder. The author considers, however, that it is better practice to use several small cylinders instead of

one large one, and thus render these complications superfluous.

Dugald Clerk has introduced a system of admitting to the cylinder, after the explosive charge has been drawn in, an inert diluent such as air, or cooled exhaust gases, which does not mix with the charge to any serious extent; the charge is compressed and ignited in the usual way, and the presence of the diluent serves to reduce the flame temperature to a remarkable extent. The result is a cool working engine, developing a greater power for a given size of cylinder, and yielding a higher thermal efficiency. An engine of 300 indicated horse-power has been built by the National Gas Engine Company on these lines.

Another device, invented by M. Banki, is to spray a few drops of water into the

cylinder during the suction stroke; this keeps down the temperature, preventing pre-ignition, and raising the thermal efficiency. This system has been adopted by Messrs. Crossley Brothers.

Small anthracite pea or gas coke is the best fuel for making gas; the cleaning of gas from bituminous coal is too costly and troublesome. The only practically satisfactory producer using bituminous coal is, in the opinion of the author, that of Dr. Mond, and this is only suited for large installations.

In the discussion on the paper, Mr. Hopkins stated that working with Dowson gas under ordinary circumstances, the

cost per horse-power year of 2,800 hours was not more than \$25 to \$30. Compared with this, the cheapest electric power supply in Great Britain—in the county of Durham—cost \$48 per horse-power year. Niagara power cost \$20, and the cheapest he knew of, which was developed from Austria water power, cost \$12 per horse-power year of 8,760 hours. It was agreed that gas power cost about 0.2 cent per horse-power hour for fuel, and twice as much inclusive of all costs, interest and depreciation, etc., even in small installations. The smallest plant suitable for ammonia recovery was said to be upwards of 3,000 horse-power.—*The Engineer.*

THE "AUTOMATIC" GAS PRODUCER.

The "Automatic" gas producer of the Automatic Gas Producer Company, 25 Broad street, New York City, consists of a producer or gas generator with the boiler, or steam generator, combined and of a combined washer, scrubber, purifier and gas holder. By combining these various items in a gas producer installation into two general devices there is a saving in space occupied. But 5 by 13 feet of space are required for the 50 H. P. plant, while 12 by 26 feet suffice for a 400 H. P. plant.

The "Automatic" gas and steam producer or generator is a simple, cylindrical, upright, water-jacketed steel receptacle, in appearance like a vertical boiler, with a grate at the bottom separating the ash space from the fire space, through which, by properly arranged pipes and tuyers, all the air and steam necessary for making gas is blown in proportionate quantity according to the requirements of the fuel in use.

The water jacketing or double cylinder construction, with water space thus provided, forms the generator's own boiler in which ample steam is generated by the heat of the fuel bed and the heat of the generated gases as they pass up and out into and through the washer, scrubber, purifier, etc.

The top of the generator is of cast iron, very heavy, and ribbed for additional strength. In the center of this top a retort is fitted and suspended therefrom in the center of the generator down to the level at which the firebed should always be kept. All coals (or other material) are fed into and through this retort by and from a prop-

erly constructed air and gas tight hopper, and spread their coked or charred product evenly and perfectly over the entire firebed from the bottom of the retort as fast as the ashbed lowers or the firebed settles to give space therefor.

All the heavy hydrocarbons that are distilled from bituminous coal or other material in the coking or charring process continuously going on in the retort, are drawn off from its top and forced into the generator through the grate and firebed, by a small steam jet blower, and thereby all of the heavy hydrocarbons are burned in the generator itself into producer gas. The amount of steam and air admitted is regulated to meet the requirements of the kind of fuel in use and the density of the hydrocarbons produced therefrom in the retort.

The gas from the generator passes by its own pressure through a pipe into and through a water seal washer; thence up through the scrubber (which consists of shelves packed with coke); thence up through two other shelves which are arranged as purifiers, which take out any remaining impurities, and thence into the gas engine.

The combined washer, scrubber and purifier is so constructed as to contain and retain at all times sufficient pure gas ready for use in the engine to compensate for any reasonable lapse or delay in generation, thus obviating the now prevalent necessity of large and expensive gas holders.

The amount of gas generated is regulated by valves which are controlled by a gov-

ernor on the top of the purifier and the pressure thereupon, so that when the gas engine stops the blower is stopped, and virtually no gas is made. This is done automatically by the apparatus itself, without care or attention from the operator. To provide for the disposition of such gases as must necessarily arise from the existing firebed at such times, a safety valve, with pipe set to carry them off into the atmosphere, is placed upon the generator to act promptly upon material pressure and allow the gases to escape.

The combined washer, scrubber, purifier

series of shelves about twelve inches apart, packed with coke which is kept wet. Openings through these shelves at opposite sides give space to allow the volume of gas generated to pass back and forth through the wet packed coke between the shelves, which removes whatever impurities may have passed the washer.

The pipe from the generator to the seal washer is covered and the air used in blowing the generator is heated by passing between this cover and the gas pipes. The following is the average of ten analyses,

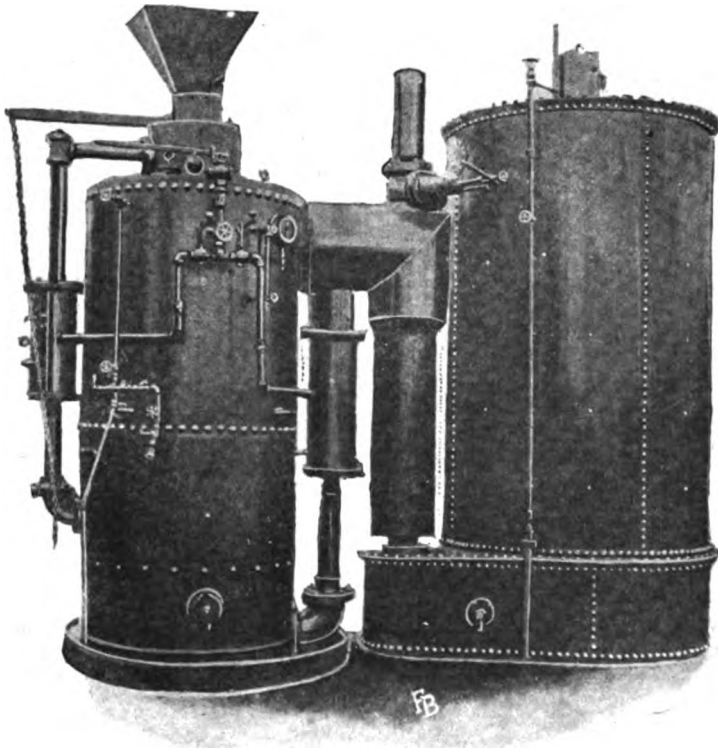

50 H.P. "Automatic" Gas Producer.

and gas holder is also a cylindrical, upright, steel receptacle. The washer is a cylindrical box, sufficiently elongated on one side to allow the gas pipe from the generator to pass in at the top thereof and down into the water, which it contains in sufficient quantity to form a perfect seal so that no gas can return to the generator, and to remove some of the impurities it has carried in suspension there.

Above the seal washer, and upon which it sits, is the scrubber, which consists of a

made by Chas. I. Goessmann, Ph.D., on September 25 to 27, 1905, of gas made from bituminous coal by an "Automatic" gas producer: CO_2 6.7555, O 0.925, CO 18.350, H 13.325, CH_4 5.300, N 55.345, average B. T. U 161.657.

Mr. F. C. Tryon, manager of the company, gives the following as the cost of coal used in the "Automatic" gas producer to run a 50 H. P. gas engine 10 hours a day for 300 days (a year):

	Per ton.	Per annum.
For coal costing.....	\$2.00	\$188.00
For coal costing.....	2.50	235.00
For coal costing.....	3.00	282.00
For coal costing.....	3.50	335.00
For coal costing.....	4.00	375.00
For coal costing.....	4.50	422.00
For coal costing.....	5.00	469.00

The labor necessary to the operation of a 50 H. P. "Automatic" gas producer and a gas engine is, comparatively, very small. The hopper and retort need filling but twice daily, and the ashes need removing but once a week.

There is no extra boiler to be fired and attended, there are no extra valves, connections, etc., to be watched and manipulated.

One man can easily take care of and run both gas producer and the gas engine.

The greater the number of heat units utilized or saved, per pound of coal used in the operation of a producer, the greater the efficiency of that producer.

In the "Automatic" producer, all the heat necessary to change coals or other fuel into a combustible gas is utilized, as and after the gas is made, to a greater extent than in any other.

First, in the heating of the retort and its contents, thereby extracting the volatile hydrocarbons.

Second, in the generation of steam in the jacket of the producer, thus furnishing the power to draw those hydrocarbons from the retort and drive them through the firebed (which changes them to producer gas), and the steam required to drive the air in, to keep up combustion and make gas.

Third, in the heating of the air before it is driven into the producer by the steam.

All this absorption and utilization of heat from the gas on its way from the coals to the purifier, is dollars saved.

By its automatic valves and connections, a continuous pressure of gas is kept in the purifying apparatus up to a fixed point. Reaching that point, the making of gas is shut off until the pressure is relieved, when it again starts of its own accord.

Thus, by its own automatic operation, only the amount of gas required from time to time is generated, while there is always a surplus in storage sufficient to take care of any overload, variation of load, or the immediate starting of engine.

THE ETNA GREEN, IND., LIGHTING STATION.

Just at this time, when so much is being said and written concerning producer gas for power and when such remarkable claims of economy are being made by builders of producers, a report of the actual results secured from a plant of this nature is interesting. Laboratory tests are always conducted under unusually favorable conditions and are, therefore, of less value to the prospective user of any apparatus than the everyday performance under every-day conditions.

An interesting producer gas installation that has been in daily service for nearly two years is to be found in the electric lighting station at Etna Green, Ind. This plant was originally operated by steam power, but did not prove to be a very successful venture from a financial standpoint, and was eventually purchased by Mr. T. M. Jones, an enterprising citizen of the town.

Mr. Jones immediately remodeled the plant, substituting a 35 H. P. Wayne gasoline engine built by the Ft. Wayne Foundry and Machine Company, Ft. Wayne, Ind.,

for the steam engine and boiler. The plant was operated by Mr. Jones in this manner until January, 1904, when an order was placed with the Smith Gas Power Company, of Lexington, O., for a producer gas outfit. During February, 1904, that company installed for Mr. Jones a 35 H. P. Smith automatic suction gas producer, and at the same time made the necessary changes on the engine to adapt it to the use of producer gas. This was all done without interfering with the regular operation of the plant, and the producer was immediately put in daily service as soon as the installation was completed. Since that time the plant has been giving regular service, every night lighting the streets, residences and business places of the town.

Mr. Jones states that the operation of the plant is much smoother and more regular on producer gas than on gasoline and that the regulation is much closer, the power being so steady that no variation whatever is noticeable on the lights. The most interesting feature, however, is the relative

operating expense on gasoline and on producer gas. For the year preceding the installation of the producer the cost for gasoline was \$600. For the year following, the producer consumed thirty tons of pea anthracite coal costing a total of \$149.50 de-

livered. This shows a total annual saving of \$510.50, which, it is needless to add, makes a very nice dividend on the cost of the producer outfit. Mr. Jones speaks very highly of the plant and takes pleasure in explaining the working of the outfit

CALCIUM CHLORIDE SOLUTION IN THE WATER JACKETS OF GAS ENGINES.

The bursting of the water jackets of gasoline engines during the winter time, due to the neglect of emptying the water over night, has been a common occurrence in the past; and many experiments have been made to place on the market an anti-freezing solution that would not affect the engine in any way, but until recently all these attempts had been more or less unsuccessful, owing to the expensiveness of the article tried or its detrimental effect on the engine. For many years thousands of tons of chloride of calcium have been used in ice factories to make the circulating brine, both on account of its low freezing point and because it has no effect on the ice cans, iron tanks, piping, etc., being found much more satisfactory than salt. With the above facts in view, and appreciating that the demand for an anti-freezing solution is increasing, some of the gas engine manufacturers decided to give calcium chloride a trial, subjecting it to the severest tests. The article itself is a hard, white chemical, forming a colorless solution when dissolved in water. It is a by-product of the salt wells, but does not contain salt (or sodium chloride) in any form. It is neutral and will not rust or affect metal of any kind, as every chemist will affirm, any corrosion that may appear to accompany its use being due to impure calcium, against which users should guard.

The freezing point of a solution made by dissolving 5½ pounds of calcium to a gallon of water is 54 degrees below zero Fahr., although 4½ pounds to a gallon, with a freezing point of 17 degrees below zero, will answer in most climates. Owing to its chemical composition, it absorbs moisture instead of allowing it to evaporate, thus making it more valuable, as the solution will last all winter—in fact, indefinitely. Should the solution boil and some of the water be evaporated in the form of steam, the calcium may precipitate on the cylinder, but by adding more water the latter will again

dissolve the precipitate and bring the brine to the correct strength. However, this seldom occurs, as the solution will boil only at 238 degrees above zero Fahr., while water boils at 212 degrees. It is also odorless and will remain so, even if left standing for an indefinite length of time; neither will it form sediment of any kind.

After dissolving the required amount of calcium in water, it is preferable to test the solution with a hydrometer or salometer. Certain manufacturers have a special salometer for this purpose which they give away free to customers or sell to them at a nominal price. The salometer is marked in degrees salometer. Floated upright in the solution, it sinks to a certain depth, and the depth as marked on the scale indicates the strength of the solution. Five and one-half pounds of calcium to a gallon of water should test 124 degrees salometer and 4½ degrees to a gallon should test 104 degrees. The accompanying table shows the freezing points of solutions of different strengths:

Commercial Calcium Chloride to Each Gallon.	Degrees Salometer at 60 Degs. F.	Freezing Points, Degs. Fahr.
½ lb.	12	29
1 lb.	27	27
1¼ lb.	36	25
1½ lb.	40	23
1¾ lb.	44	21
2 lb.	52	18
2¼ lb.	62	14
2½ lb.	80	4
3 lb.	88	— 1.50
3½ lb.	95	— 8
4 lb.	104	—17
4½ lb.	112	—27
5 lb.	120	—39
5½ lb.	124	—54

(The sign — means below zero; all other degrees in last column are above zero.)

Calcium chloride is packed solid in drums of 650 to 700 pounds. The drums are made of sheet iron, and the calcium is poured into them in a hot, liquid condition, and hardens into a stone-like substance when cooled. It must be broken up before dissolving by pounding the drums along the sides with a sledge hammer or axe before opening, the jarring breaking the calcium into pieces large enough to be thrown into the tank to be dissolved. As it absorbs moisture readily, it will dissolve very quickly, but frequent stirring will quicken the process. It is absolutely necessary to dissolve all the calcium before starting the engine and the solution then tested with the salometer. Warm water will also help dissolve the calcium quicker, although this is not absolutely nec-

essary. The metal drum, being worthless, can be thrown away.

Calcium chloride brine will also be found superior to salt brine for fire barrels in elevators, as it does not evaporate nor rust the iron hoops on the barrels, thus causing them to weaken and finally to burst. It is also a better fire extinguisher and is heartily recommended and approved by every insurance company. In every 30-gallon fire barrel (if full) 135 pounds of calcium should be dissolved; if 45-gallon barrels, 200 pounds each is required.

James H. Rhodes & Co., 117 East Kinzie street, Chicago, Ill., are importers and dealers in chemicals, and make a specialty of a calcium for use with gas and gasoline engines.

MOTOR BOATS IN AUSTRALIA.

How firm is the hold which the motor boat has taken in Australia is well evidenced by the rapid rise to popularity of the Sydney (N. S. W.) Motor Boat Club. In less than two months 110 boats have been entered on the books of the club, and that before the commencement of the boating season. The popularity of the pastime in Australia is by no means confined to New South Wales, for on the Swan River, in Western Australia, there is quite a large fleet of motor launches, and races are held from time to time by the yacht clubs; in Victoria there is the Victorian Launch Club, which promotes races on the Yarra River. In fact, throughout Australian waters motor launches are in widespread use, and their total number must run into four figures.

Though quite a separate country, and seven days' distant from Australia, New Zealand affords another proof of the position occupied by the motor boat in Australasian waters. One firm alone during the past ten years supplied over 400 launches to various parts of New Zealand and to the Fiji Islands, and, it is almost needless to add, those motors were American, varying in power from 2 H. P. to 100 H. P.—in one boat, a lighter, two 75 H. P. motors have been installed to drive twin screws. Large Harbor Board launches are equipped with oil motors, trading vessels and yachts are driven by them, pleasure boats, ferry craft, in brief, examples of every type of craft are

to be found equipped with motor power.

And how much of the trade is in the hands of British motor manufacturers? Very little; in fact, we have been assured that English motors are almost unknown. Yet there is an opening for them, as the American oil engines sold in Australasia are not to be purchased at a low figure. Far from it; there are complaints against the high prices charged for them. Now why, it will be asked, does the American motor hold the field? We must confess we can not reply; but, in part, it may be said, it is due to the twelve years' exploitation of the market by the Americans. Perhaps a little enterprise and study of the local requirements would bring a little trade to this country.—*Motor Boat*, London.

A medical man, writing to *The Tribune Politique* of *La Vie Automobile*, says: "I have read, and I have also been informed, that automobile engineers are far from being agreed as to the exact moment at which the inlet valve of a gasoline engine should be entirely closed. In some engines these valves are closed exactly at the moment the crank reaches the dead center, in others just before that period, while in many others the moment of inlet valve closing is set appreciably after the crank dead center. In the last-named case the writer suggests that one of the alleged defects of the automatic valve is retained,

DOES POWER PAY THE BLACKSMITH ?

I have noticed several times the question asked, Does power in the shop pay? In answer I want to say, yes, it pays—and not only pays, but pays big. I have been in the business for over twenty-five years and speak from experience. The first ten or twelve years I hammered away, and sweated and wiped off the sweat and went at it again and hammered out from \$1.50 to \$2.50 per day. So I came to the conclusion that there must be an easier way to run a shop than that, so I bought a 6 H. P. engine and boiler and an iron lathe and with them I made several other machines and soon found that I could do more work and do it better than two of us had been doing and a great deal easier. But steam

power was not satisfactory; it took too much time to look after the fire and water, so I bought a 4 H. P. gasoline engine, which is the very thing itself. I can set it running and go off upstairs and work for a half day and it runs as well as if I was standing by and watching it. With it I can do as much work as three men can by hand and do it much easier, and besides can do work that we could not do by hand, and it costs about fifty cents to run it ten hours. Now the question is, would it pay you to hire two hands that could do as much work in a day as you can for fifty cents a day? You would say of course it would.—*Blacksmith and Wheelwright.*

THE ENDTER FRICTION CLUTCH PULLEY.

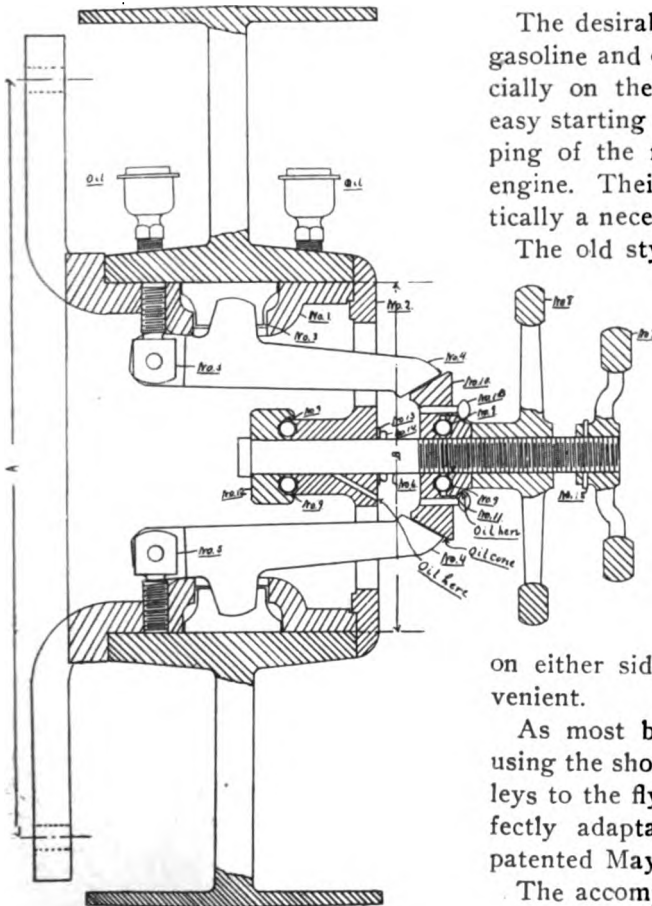

The desirableness of a clutch pulley on gas, gasoline and oil engines is unquestioned, especially on the larger sizes. They permit the easy starting of the engine and the quick stopping of the machinery without stopping the engine. Their use on portable engines is practically a necessity.

The old style shaft clutch is expensive and unmechanical, requiring a long crank shaft and, in most cases, an out bearing. The necessity for something better has led to the introduction of what is known as "the short shaft clutch;" that is, a clutch which is independent of the shaft and is bolted to the arms of the fly-wheel. This arrangement allows the use of a short shaft and the placing of the pulley on either side of the engine as is most convenient.

As most builders of gas engines are now using the short shaft and bolting the band pulleys to the fly-wheel, the Endter clutch is perfectly adaptable. This type of clutch was patented May 10, 1898.

The accompanying half-tone gives a correct

idea of the clutch pulley ready to attach to the engine. On large sizes steel rim pulleys we used on account of their lightness. The pulley is neat, compact, and takes up the minimum amount of space, only about six inches more than the plain bland pulley. The sectional cut will show how it operates.

The pulley proper is mounted on a hollow bearing or spider (1), having arms for bolting to the flywheel. In the bearing is a



The Endter Clutch Pulley.

recess or groove in which lies a friction ring (3), cut in two parts. Attached to the bearing by means of studs (5-5) are two levers (4-4), having wedge-shaped lugs extending between the ends of the friction ring (3). A face-plate (2) is bolted to the bearing or spider. This face-plate provides a journal for the spindle (6). The inner end of the

spindle is provided with ball-bearing thrust collar (12). Mounted loosely on the spindle is a cone (10), which also forms part of a ball-bearing with its casting (11). Also mounted on the spindle with a thread is the hand-wheel (8). On the outer end of the spindle is the hand-wheel (7) rigidly fastened to it.

Supposing the engine to be in motion and the clutch disengaged, the pulley proper will remain at rest while the spider and its attached parts revolve. To engage the clutch, grasp the hand-wheel (7) with the left hand. The spindle (6) is now at rest, the revolving parts turning on the two ball bearings. With the right hand turn the hand-wheel (8) to the right until the pulley carries the full load without slipping. As the wheel (8) is threaded on the spindle, the cone (10) forces the levers (4-4) apart and the wedge-shaped lugs expand the friction ring (3) out against the hub of the pulley, locking it to the bearing.

Being engaged by a screw, the clutch must be positive and powerful. It will also be noted that no adjustment is ever required, as the friction cone takes up all of the possible wear.

The clutch can be supplied with gears, sprocket wheels, or sheaves for rope or steel cable. The manufacturers are the Springfield Gas Engine Company, Springfield, O., who have just issued a catalogue, No. 14, giving further details, prices, etc.

SOME LUCID DESCRIPTIONS.

Among our Western clippings we recently noticed the following, which will bear reproducing:

"While out in the river yesterday Ed Maurer's boat met with a peculiar accident which for a time appeared to be serious. A match in some manner got caught in a valve in the carbonator, holding the valve open, and the engine refused to work. The anchor was thrown out and the boat caught on the reef near Lehman's Landing."

"The motor has therefore two impulses instead of one at every revolution of its cylinder crank, and by the adjustment of the crank a two-cylinder engine is produced that, with its increase of horse power, runs steadily, and by the balancing of the explosive impulses has absolutely no vibration, yet running at a rate of 3,000 r. p. m."

"A. W. Priest and a party of friends, among whom were two salt-water sailors, were out on the river Saturday evening and in returning to the boathouse about 7 o'clock, the bow of the boat got away from the sailors and Itola was caught in the strong current and, washing against the St. Paul Bridge, a hole, 6 inches long, was cut in the side of the boat, and it was with great difficulty that the little launch was kept above water."—*Power Boat News*.

The cost of building a high-powered racing car is seen to run up rapidly when we are informed that the crank shaft for a six-cylinder racer is made of nickel steel and weighed 375 pounds in the rough, but was machined down to 75 pounds in weight.

A GAS-DRIVEN COUNTRY HOUSE ELECTRIC LIGHT INSTALLATION.

Although it costs more to instal than acetylene and other illuminants, electricity continues to hold its own as the light for country houses. The convenience of being able instantaneously to flood a room with light as, or even before, it is entered, the comfort of being able to move a lamp from point to point and place it in any desirable position, the absence of heat, smoke, fumes and dirt, and the ease of producing decorative effects, still keep electricity far ahead of all its rivals. There is no doubt that in the past the capital cost of private installations has been in many cases excessive, much higher than it should have been, but, quite apart from possible extravagances and excessive charges by contractors, the generating machinery at the command of engineers and electricians has, with a few exceptions, been of an elaborate and expensive character. Steam plants, the first cost of which has been very heavy, have often been installed in order to avoid the smell and noise which is made by oil engines when they are erected or looked after by unskillful or careless people. Because oil engines have sometimes been badly arranged they have been badly libelled. An oil engine need not smell, nor need it make a noise; both defects are quite unnecessary if simple precautions are taken to guard against them. In the majority of cases these precautions are taken, and consequently a very large number of private installations are driven by oil engines.

Within the last two years the advantages of internal combustion engines for estate work have become even more widely recognized, and the suction gas producer has enabled the gas engine to take the place of steam, and in some cases that of oil engines.

The low first cost of the gas plant and engine compared with the steam engine and boiler, the extraordinary low fuel consumption, and the absolute safety of the gas plant have enabled estate owners to produce electric light at a cost undreamed of three years ago; at a cost in fact which, after paying interest and allowing for depreciation on the cost of the installation and providing for the wages of the attendant, is in the majority of cases less than half the cost per

unit of electric light in the towns, and about a third of the cost of electric light generated by an installation driven by steam engines and boilers. So great indeed is the difference in cost between the two systems of generation that in many cases owners of big country houses are having their steam engines and boilers taken out, and suction gas plants and gas engines substituted for them.

We are enabled to publish a description of a country house installation, which is interesting as being one of the very first installations in England in which suction gas was used for estate purposes, and from which, therefore, the longest records can be obtained. Campfield Place is the residence of Mr. F. V. McCornell, and is situated in Hertfordshire, about $3\frac{1}{2}$ miles from Hatfield Station. Before the electric light was installed, a steam engine with boiler was in constant use for pumping water from a well some 170 feet deep, and delivering it to the top of a water tower commanding the mansion. The cost and the cartage of the coal proved an expensive and troublesome matter, and when Mr. McConnell called in Messrs. Hal Williams and Bridges to advise him on the engineering work on his estate they decided to put in a suction gas generator and gas engine in order that the double advantage of the great economy in the cost of production and the small amount of coal used might be secured.

The existing building was utilized, both the steam engine and the boiler being taken out. The engine is of 14 B. H. P., and together with the gas plant was supplied by Messrs. Andrews, of Stockport. It is of the latest design for working with suction gas, high compression and magneto ignition being used. On account of the small amount of room at the disposal of the engineers, the engine is run with an over-thrust, driving on to the dynamo off the fly-wheel, and on to a countershaft off a pulley. From this counter shaft the deep well pump previously referred to is driven by belt.

The engine can be started by running the dynamo as a motor, taking current from the lighting batteries, and this method has been found exceedingly convenient and expeditious. The suction gas plant is fitted

with an electrically driven blower so that the fire can be got up and gas generated while the driver is oiling his engine and getting ready to run.

The lighting battery is placed some little distance from the engine room, an empty chamber under the water tower having been utilized for the purpose. It consists of 54 cells, having a capacity of 480 ampere hours. The coal consumed by the plant is anthracite beans, costing \$6.72 per ton delivered; the consumption in ordinary working is under one pound per B. H. P. hour.

As illustrating the economy of the plant it is interesting to note that less than 10½ tons a year of this coal is sufficient to generate all the electricity and pump all water required by mansion, stables and farm. The whole plant is regularly run and looked after by one of the gardeners on the estate, and, as this was his first introduction to gas engines and electricity, it speaks very well for the simplicity and reliability of the plant that he has been able to manage it with ease ever since its installation.—*Gas and Oil Power.*

DESIGN OF LARGE GAS ENGINES.

At the recent convention of the American Railway Association, Mr. Arthur West read a paper on the design of large gas engines, in which he first took up the arrangement of the cylinders. In a single-cylinder, single-acting, four-cycle engine an explosion takes place once in every two revolutions. In order, therefore, to get the same rotative effect as with a double-acting steam cylinder, it is necessary to work four single-acting cylinders on the shaft, or two double-acting gas cylinders tandem on one crank pin. With this arrangement, four explosions are obtained in two revolutions, or an explosion every 180 deg. of crank angle. In case of a misfire or premature ignition due to bad gas, the crank can only move one-half a turn before another explosion takes place. In a single-cylinder, single-acting engine the crank must move two whole turns before the next explosion, while with two single-acting cylinders opposed to each other, or one double-acting cylinder, the crank may be required to move one and one-half turns before the next explosion. The relative evil effects of a premature or misfire are, therefore, in the following ratios: Two double-acting cylinders, 1; two single-acting cylinders, opposed type, 3; one double-acting cylinder, 3; one single-acting cylinder, 4.

Gas engines and producers, to be commercially successful, must be designed to be run with the same class of help as is employed on Corliss engines and boilers. This being the case, misfires and prematures are liable to occur occasion-

ally, and the designer must minimize their possibilities for evil. These considerations, as well as the capacity for caring for heavily swinging railway loads, have caused the adoption of tandem double-acting cylinders for railway work by the Westinghouse Machine Co.

It is sometimes argued that cylinders so arranged are inaccessible. If, as is the practice of the Westinghouse Co. ample space is arranged between the cylinders, and if the inlet and exhaust valves are not located in the heads, but in the cylinder body, and entirely above the floor level, such a gas engine is as accessible as a tandem compound Corliss engine or as a Corliss engine driving an air compressor.

The speed of a gas engine must be adapted to the kind of generator to which it is to be directly connected. In a general way, its speed will usually somewhat exceed that of a Corliss engine of the same cylinder dimensions. In Mr. West's experience, the speed of large steam engines is limited by the inertia and consequent wear and tear of the valve gear, rather than by the inertia of the reciprocating parts themselves, which is absorbed by the compression. Inasmuch as in a four-cycle gas engine the valve gear only moves at half the speed of the engine, somewhat higher speeds are permissible than would be the case with a steam engine having the same dimensions of cylinders.

The speed regulation adopted for large Westinghouse gas engines is especially suitable for generator driving, in that no

conditions of changeable load or variable friction of valve gear affect the regulator. The gas engine regulator governs the speed by means of a relay cylinder, and, therefore, produces results similar in type to those obtained with the relay governor used by the Westinghouse Machine Co. on steam turbines. The advantage of such a governor with the gas engine is that the varying friction of valves with different qualities of gas does not affect the sensitiveness of the governor. Without a relay cylinder the only way in which this result can be accomplished on large gas engines is by some form of a drop cut-off controlling the gas. This is objectionable on a gas engine, as any slight change in the speed of the dash pot very seriously affects the mixture of gas and air, with corresponding bad effect on the regulation. Such small changes in speed of dash pots are frequent in a Corliss engine, where they cause no bad results. The Westinghouse arrangement employs no releasing gear of any kind, but secures all the advantages of regulation without its use.

The European designer of gas engines has allowed himself an amount of complication in valve gear which would not be permissible under American operating conditions. The successful American machine must be as nearly "fool-proof" as is the large Corliss engine. If it is not, it will fail to be a success from the purchaser's point of view—no matter what thermal efficiency may be claimed by the builders—as a consequence of such complication as the European engineers have been prone to adopt. In the designing of valve gear for large gas engines, wide range of quality of gases must be considered. In this respect the design of the gas engine is very different from that of a steam engine, inasmuch as the steam used has practically constant characteristics, differing only in such minor points as pressure and superheat. With the different kinds of gas to be met with, however, the proportions of air and gas, and sometimes of compression are radically different, and no gear can hope to be a universal success which does not provide for meeting the widely varying conditions to be encountered in the market.

The question is frequently asked, "What is the overload capacity of the gas

engine?" A clear understanding on the part of the purchaser of the limitations in this direction is very desirable, from the point of view of both the buyer and the seller. A gas engine and producer is thermally much more efficient than a steam engine and boiler. With a well designed producer and gas engine plant, a horse power can be delivered with one-half the cost of fuel that is possible with a well-designed steam engine plant. The power of the gas engine, however, is limited by the total volume of explosive mixture which can be drawn into the cylinders during the suction stroke, compressed and finally ignited. This condition sets a limit which does not allow of a large temporary increase of the power, such as obtained with the Westinghouse steam turbine by the automatic operation of the secondary admission valve. Such overload capacity is, of course, convenient for the purchaser, but it is unobtainable on a gas engine, unless the engine is largely under-rated, and the purchaser should consider that this is one of the prices he pays for the enormously increased output obtained with the gas engine per pound of coal. The overload capacity is, therefore, simply the amount which the builder rates his machine below its ultimate capacity. It has been the Westinghouse practice to rate gas engines in such a way that they would have a safe overload capacity of ten per cent. The machines are ordinarily good for somewhat more than this, but conservative engineering requires that there be a margin of power, in order that overloads may not materially reduce the speed. For ordinary cases the overload capacity of the generator and that of the gas engine should be about equal, in Mr. West's opinion, although the gas engine will indefinitely carry its overload while the generator will not, in all cases, unless it is bought with that understanding.

The mechanical efficiency of a large gas engine is very much greater with a four-stroke cycle than with a two-stroke cycle, this being one of the arguments against the two-cycle engine. It is no uncommon thing to see two-cycle engines which do not realize as brake horse power more than 60 per cent of the work actually done by the combustion in the cylinders. The efficiency of a four-cycle

engine varies considerably, but it may be said in a general way that a well-designed engine will deliver about 85 per cent of the gas indicated horse power in the form of brake horse power. This 15 per cent of power lost is not exclusively composed of fractional resistance of journals, cross-head slides, etc., as is the case in a steam engine. The four-cycle engine has, of course, to draw in its own mixture of air and gas and compress the same, and its functions, therefore, combine those of a pump, a compressor and a motor. It is the pumping and compressing work which causes the mechanical efficiency of the gas engine to be somewhat lower than that of a steam engine. The actual friction of the working parts need be no greater than with a well constructed Corliss engine, viz., 90 to 95 per cent. In order to keep down the friction and increase the reliability of the machines, it is the practice of the Westinghouse Co. to design large gas engines with provisions for attaching a continuous return oiling system. The large amount of oil put through the journals increases the safety, requires less attendance and keeping up, and washes out dust if the engine is required to operate in an atmosphere which is not clean.

The thermodynamic efficiency of the gas engine varies so much with different kinds of gas that it is hard to say just what the average value would be. It is probably not far from the truth, however, that its thermal efficiency is about 25 per cent, though in favorable cases gas engines have obtained efficiencies well over 30 per cent.

There is an impression rather prevalent that a gas engine is uncertain and hard to start. A properly designed engine, supplied with fairly decent gas, can be started as easily as a steam engine. Large Westinghouse horizontal gas engines are started by means of compressed air, the only operations required being (1) open the main gas valve; (2) close the igniter circuit; (3) open one compressed air valve, similar in construction to an engine throttle. The compressed air puts the engine in motion, which draws the charge into the cylinders and compresses it, after which the first explosion takes place. Air is shut off and the engine is in full operation. Mr. West said there was no more difficulty in start-

ing gas engines than a steam engine

With certain kinds of gas, inspection of the interior parts of the cylinders is often desirable at regular intervals of, say, a couple of months. This is especially the case with blast furnace gas, and also with producer gas made from certain kinds of fuel. The Westinghouse Co. has taken particular pains to arrange its cylinders so that no part of the valve gear or valves are below the floor. The inlet valves being located directly on the top of the cylinder, easy access can be had to either end of either cylinder by removing the inlet bonnets. The exhaust valves are also a part of the engine which need occasionally attention for regrinding. Especial care has been taken to render these quite easily removable. The cylinders are, therefore, directly accessible from the top through the exhaust openings. The fact that all the valve parts are entirely above the floor line renders these operations much easier than if a large part of the valve gear extended downward into foundation parts. It is not necessary to remove the cylinder heads, except to examine the piston rings themselves, which is not often required. Inasmuch as clean gas can not always be secured, the importance of such easy entrance to the gas cylinders can not be overestimated.—*The Engineering Record.*

Palmer Jordan, a farmer living at Danielson, Conn., is doing almost all the wood-cutting in his neighborhood at a low rate. He bought an old automobile in Providence, R. I., a few weeks ago and fixed it up so that he can attach a belt to the machinery to run a saw. He carries the saw around in the automobile and goes from one farmer to another, cutting their wood for them.—*Boston Herald.*

M. Michel Werner, a pioneer European motor-cycle inventor, died during August. He built his first motor-cycle in 1896.

We have received from Mr. Reinhold Betterman, Johnstown, Pa., drawings showing an adaptation of a suction gas producer and direct connected gas engine and electric generator for operating the usual type of river boat.

GAS - ENGINES FOR LARGE VESSELS

On the subject of the use of gas engines for marine purposes, the Glasgow *Herald* recently said: "It is significant of the progressive attitude of the technical officers of the Admiralty—especially in the engineering branch—that they decided to apply experimental gas engines with producers instead of steam engines and boilers for the propulsion of large vessels, before any ship-owner was found with courage to essay a departure, though experience in land stations promises most economical results. An installation now being constructed at Manchester will be applied by the Admiralty; and as the power to be developed is 500 B. H. P., it will be recognized that the test is to be on a thoroughly practical and searching scale. While thus giving credit to the Admiralty, it is but fair to make mention of the splendid pioneer work carried out, and being continued by Mr. William Beardmore, of Glasgow, in this respect, alike for marine and for land work. It is

now some years since Mr. Beardmore took up the work, acquiring the British rights in the Oechelhaeuser engine, one of the simplest and most popular of the Continental designs. The success of the application of this horizontal engine, several of which are now in use in the West of Scotland, led him to investigate fully the adaptability of the system to marine work; and now there is being built a 500 and a 1000 H. P. installation for ships, and these may be ready for use before the Admiralty sit. An effort is to be made to use the cheapest bituminous coal for the generation of the gas for the engines; and there seems every chance of success, with a satisfactory method of purifying the gas to prevent the clogging of valves. Should this be realized, and the consumption come out under 1 lb. per horsepower per hour, the coal bill will be halved, and at the same time more room will be made available for cargo by the reduction of the size of engine rooms.

GAS ENGINE DRIVEN RAILWAY STATION.

The Warren & Jamestown alternating current railway system, operating between Warren, Pa., and Jamestown, N. Y., has been recently started. The electrical equipment has had several weeks' preliminary run: from a small gas engine driven unit temporarily installed in the power house at Stoneham. On the 19th of October the large gas engines were placed in service for the first time and a permanent operating schedule was inaugurated.

Probably the most interesting feature of this rather unique railway system is the exclusive employment of horizontal double-acting gas engines of the heavy duty type for the generation of power to operate the road. Two of these engines are now installed, the first of which is already operating. The second will be placed in service in a short time. These two engines will be called upon to operate in parallel on the electrical end. Parallel operation is particularly difficult in service of this kind on account of the violent fluctuations in load which occur, due to the size of the cars employed and the small number in operation at

any particular time. As it is not possible to utilize storage batteries to absorb these fluctuations, the engines are called upon to sustain them and are thus put to the severest possible test occurring in the operation of electric power plants.

The two units installed are each of approximately 500 B. H. P. capacity direct connected to 260 K. W. revolving field engine type single phase generators. Each has two cylinders arranged in tandem fashion with a single crank. They will operate entirely upon natural gas distributed by a local company. In this district the gas has a calorific value of 1,000 B. T. U. per cubic foot. A 55 H. P. vertical engine of the single type is also in operation, driving air compressor and exciting unit for the main equipment. Westinghouse engines are used.

Current is generated directly at a voltage suitable for transmission without the use of transformers. Transformer substations are located along the right of way which reduce the line voltage to 3,300 volts for the trolley at which pressure it is collected by the cars.

The Warren & Jamestown Street Rail-

way, although recently organized upon its present basis, has been running part of its present line for eleven years. Three years ago it began experimenting with gas power with sufficient success to induce the use of

gas engines for the entire power generation. The successful starting of the power system will be accepted with general gratification, and will mark an important advance in modern electric railroading.

**“WHAT CAUSED THE GASOLINE ENGINE
TO STOP?”**

We have never been able to quite forget or hardly to forgive some of the remarks of a gentleman in a paper which he read on the subject of gasoline engines, some two or three years ago before a meeting of mechanical engineers.

The reader of the paper is, of course, supposed to be the author of it, and a man who should have been able to give a good reason for every assertion made in it. Another singular thing is that in the gathering of men which listened to his paper there wasn't one to challenge the remarks referred to, in the discussion of it. After reviewing in general some of the advantages of the gas engine over other prime movers, his paper read something as follows: "But there is one serious drawback to the gas engine. It has a habit of bucking. It oftentimes stops and will not start again with any amount of turning of the wheel. But leave it a while, go back to it and it will start right off at the first turn, and *you nor no one else can tell what you did to make it go, or why it would not start before nor why it stopped.*" We have heard similar remarks from other sources, but not from persons who made any pretense or who really had any claim to being a gasoline engineer.

The expression not only acknowledges ignorance on the subject by the person making it, which is no disgrace, but he should not couple with it the idea that every one else is as ignorant on the subject as himself. To do this tastes strongly of egotism. We desire to say with all the emphasis possible that a gas or gasoline engine never stops of its own accord without a *good reason* for it, and it is then up to the operator to find the cause or reason.

We are going to try to tell you of some of our experiences, and causes for stopping as we found them. Not over a week ago a gasoline traction engine, which had carried two of us and pulled a heavy corn shredder for about seven miles over a hilly and fresh gravel road, all of a sudden gave two weak

exhaust reports in succession and died. Our first thought, as it was about 10 o'clock at night, was that it had gotten into an unusually bad spot in the road and become suddenly overloaded. But after getting a lantern we found that this was not the case. The cylinder lubricator was feeding the lubricating oil too fast and the surplus ran into the compression end of the cylinder and fouled the gasoline as it entered, as well as the sparker points by coating them over with oil.

After mopping out the cylinder thoroughly through the sparker port and wiping the sparker points dry, the engine started off nicely. Had we left the engine to itself for a couple of hours until the heat in the cylinder would have dried the points and vaporized all the gasoline mixed with the lubricating oil the engine would no doubt have started again on the first trial. With the fellow who knows nothing but turn the wheel nor tries to *think* out in a reasonable way the cause, this would have been a case of "bucking," one that "*he nor no one else knew what was the matter nor what he did to make it start.*"

An engine recently stopped in the writer's presence apparently without cause. When we went to turn the flywheel we found it was very hard to turn. We put our hand on the wrist box and found it so hot that it bound tight. The box had received no oil for some time and was perfectly dry. We at once took the box apart to see if it was damaged and found it in good shape, cooled it, and adjusted it in place carefully, oiled it well and started the engine the first turn over. I ran right along ever since without even warming up. In an engine that stopped frequently under a load we found a cracked exhaust valve seat that let out a good portion of the explosive force. A new valve fixed it like a charm.

Another one that was troubled with stopping had a badly corroded valve seat which prevented it from holding the compression.

When the valve was ground to a good seat its trouble was over. We find many engines so badly worn out in cylinder, piston and rings, that they can do nothing else but stop when the least load is put onto them. They are just about able to develop enough power to keep themselves going. New rings, a new piston and reboring the cylinder is the remedy.

The very worst and most annoying cases of stopping, and in fact not starting, is the engine in the hands of the fellow who is constantly "adjusting" something and doesn't know why. We have seen them so badly over-adjusted, a piece of leather here, a string, wedge of wood or strap there, until the valves are actually not allowed to seat at all, and the sparker points are constantly in contact, making a continuous short circuit on the battery. When we get the wedges, leathers, strings, etc., cut off and the parts put back in their proper places again these engines start off as nicely as ever, and run without any indication of stopping. If the engine is operated with the electric spark, a loose wire connection at the battery, engine or spark coil, will cause it to stop. An exhausted battery, a short circuited coil or a short circuit anywhere between battery, and wire connections, are all frequent causes of stopping.

We recall an engine that had "the stops," in Southern Michigan. After looking it all over carefully and finding everything about it and the battery in good order we began to follow the exhaust pipe and found it standing about 35 feet high or the full height of a three-story building with a muffler on top. This vertical standpipe was connected to about ten feet of horizontal pipe from the outside of the building of the engine. We found the muffler "chuck full" of soot. We took it off, disconnected the 35 feet of vertical standpipe and left the engine exhaust right into the alley through only the ten feet of horizontal pipe, and the result was almost miraculous. The cure was complete. After cleaning the muffler we screwed it onto the end of the horizontal pipe in the alley and left off the long vertical pipe entirely. We left the engine in excellent operation and the owner happy. Avoid long and many turns in the exhaust pipe. They cause back pressure and do not allow the cylinder to clean itself.

Many engines come under our notice that are afflicted with stopping that have the cams and cam rollers that operate the ex-

haust valve so badly worn that the valves open too late and closes too early, cutting the "breath" of the engine short at both ends. It can not let out all the burnt gases from the cylinder. It is therefore partially choked with foul gas all of the time. In other words it can't breathe well. It can neither inhale or exhale effectively because its exhaust valve does not open at the proper time nor remain open long enough. A new cam and roller is often all that is necessary. A bent or sprung exhaust lever will cause the same trouble by not lifting the valve high enough from its seat.

Improper cooling of the cylinder is often found as a cause of engine stopping. The cylinder gets so hot that the lubricating oil burns and the result is premature ignition and sticking of the piston in the cylinder. Overheating comes under the same head as improper cooling. But overheating does not always mean that the cooling apparatus is entirely at fault. The cooling arrangement may be effective enough if other conditions are favorable. Almost any engine will get hot enough to preignite its charges if there is a slight leak at the exhaust valve or if the valve does not open in time nor remain open long enough. Preignition, then, is a result usually of overheating, which in turn is a cause of stopping, but the cooling device alone may not be the only point to look to for a remedy. We have not named nearly all of the causes we have found for stopping of the engine, but some of the most frequent. Please don't forget that there is a cause in every instance. Will you work it out?—*Canadian Implement Vehicle Trade.*

We may as well face the fact that, until some one invents a new system of internal combustion or a new fuel, or some startling novelty in the way of a simplified transmission, there is little likelihood of our achieving any radical improvements over present motors, transmissions and running gears. The improvements of today are matters of detail merely—an improved ball bearing, a simpler spark coil, or more reliable magnet, a metal-to-metal clutch, a steel stamping in place of the more costly forging, and the like. We do not have to build hundred-horsepower steel cobwebs to develop or test such things as these.—H. L. Towle, in *Motor.*

A NARROW ESCAPE.

Afloat in a launch with a corpse as his sole companion, and not knowing how to stop the speeding boat, was the thrilling experience of James Parker, of Findlay, O., in the North Channel of St. Clair River, near Detroit, on November 3.

Mr. Parker and a friend were out in a small launch and when about two miles below Pearl Beach the friend turned around to adjust something on the engine. When he turned to the wheel again he suddenly collapsed. Mr. Parker, who was seated in the stern of the boat, went forward to assist the stricken man.

All this time the launch was speeding on. Mr. Parker knew nothing of the workings of the boat. It headed for the rushes near shore and threatened to run aground. The bewildered man had seen his dead companion work the wheel. He grasped it, and after a couple of turns learned which way to

swing the boat. He succeeded in getting the little craft into deep water, but was utterly ignorant as to how to bring it to a standstill.

Keeping the launch on a straight course Mr. Parker came in sight of Pearl Beach in another half hour. Again the predicament of stopping the launch stared him in the face, but he was equal to the occasion. The boat sped by Wardell's grocery, circled around and came back only to repeat the performance. People in the store were attracted by the strange actions of the boat and after it had made several more circles a launch was sent out to ascertain the trouble. All power was turned on the second launch, and after an exciting chase the boat, bearing the corpse was overtaken. A man clambered on board and shut off the engine, after which the craft was towed ashore.

ENLARGEMENT OF THE ROCKLAND GAS ENGINE PLANT.

To the Rockland Electric Company, of Hillburn, N. Y., belongs the credit of inaugurating an interurban electric supply system from by-product producer gas fuel in connection with power and fuel gas supply to adjacent industrial works. The use of gas power arose from the extremely low fuel cost of gas power and from the advantages of fuel gas in furnace work. The present power equipment, totaling about 1,075 B. H. P. generating capacity, not including an exciter unit, consists of three 19 by 24 inches Westinghouse double acting gas engines direct connected to 225 K. W. two-phase generators and a 75 K. W. vertical three-cylinder unit for operation during light loads upon the plant.

Having found its present equipment inadequate to meet the increasing demands for electricity, the Rockland Electric Company has placed an order for two additional 23 by 30-inch two-cylinder double acting horizontal tandem gas engines. These engines will be of the four-cycle type, imparting two impulses to the crank shaft at each revolution irrespective of the load. Each will drive a 60-cycle alternating current generator and will operate on producer gas of approxi-

mately 125 effective B. T. U. per cubic foot. The normal rating of each engine will be 470 B. H. P., and each will be capable of developing 10 per cent overload for a period of two hours.

The gas power plant of the Rockland Electric Company has been in continuous operation during regular working days for nearly a year, supplying current for lighting the surrounding towns, power for adjacent Ramapo Iron Works and fuel gas for a number of heating furnaces. The principal product of the gas plant—water gas—is exclusively used for this purpose on account of its high flame temperature, while power gas is a by-product. Both gases are generated by one system—the Loomis-Pettibone—three complete generating sets being in use. It is frequently the case that the cost of electric current in small suburban communities is prohibitive to a large number of residents, resulting from the high cost of generating steam power; but in this case, owing to the ability of the gas engines to thus turn to useful account a practically waste product, the cost of current is greatly reduced and the cost of an otherwise expensive gas is decreased.



An Illinois concern is reported as having brought out an automobile plow.

A company, with a capital of \$150,000, is to operate an automobile line between the cities of Osaka, Sakai and Ohama, in the Philippine Islands.

Continuous agricultural operations by night were shown to be possible by an experiment in England recently. The field was illuminated by acetylene gas, and two six-foot mowers were attached to a gasoline tractor. Fifteen acres of grass were cut in 3 hours and 35 minutes.

A Parisian theater has rigged up a gasoline engine from an old-style automobile for use in the second act of a play, "Bonheur des Dames." In this act a motor car is supposed to be standing outside the house shown on the stage, and the engine is started up so as to make more realistic the noise of the car "outside."

The value of alcohol as a fuel for internal combustion engines is still receiving attention from many of the gas engine experts of the country. We hope at an early date to be able to present the results of some tests which will soon be conducted by an eminent authority in this country. A bill covering the internal revenue tax on alcohol is again to be brought before Congress at its next session, and it is to be hoped that some satisfactory bill will be passed. While it is not expected that such a bill will at once result in the widespread adoption of alcohol

as a fuel to the exclusion of gasoline, or other fuels, yet such a measure will encourage experiments and actual tests which will be of great value and will result in giving us another fuel in readiness, should conditions affecting the price and sale of gasoline require. It is not beyond the bounds of possibility that alcohol would not come into more or less general use at once as a fuel for this class of engines. At any rate we hope that the bill to be presented to Congress may contain proper provisions and that Congress may act favorably on it at this session.

A lecture was recently given before the Automobil Technischen Gesellschaft on the "Constructional Possibilities of Carburetted Hydrogen Motors With Increased Flywheel Momentum at Fewer Revolutions." The lecturer showed by means of lantern slides, designs of a five-cylinder motor demonstrating the possibility of driving advantageously highly-powered automobiles and large and powerful marine motors with carbonic acid gas, and that the motor would yield the great carrying capacity at any desired number of revolutions, and by an increase in consumption would develop a proportionately increased power. By these means the complications of the gear and friction transmissions of the present day automobile, with their unquestionable drawbacks, would be dispensed with. The designs showed three cylinders for developing power, one cylinder for the pump, and one for starting the engine. The speaker pointed out that no damage would be suffered through any misfiring on this five-cylinder motor, as is too often the case on the best of the present four-cylinder motors, but would always remain in motion through the working of the secondary motor, though naturally losing in speed.

RESULTS OF ECONOMY TESTS.

On October 30th, nine entrants started from New York for Philadelphia on the economy test of the New York Motor Club. The return trip was made on October 31st. November 1st they went to Albany and returned on the 2d. New York to Southampton, Long Island, was made on the 3d, and the return on the 4th. Two of the nine entrants were obliged to drop out, owing to stripped gear. The total distance was about 700 miles.

An observer was carried on each car, and these observers were charged daily. Moreover, they were appointed by those having contesting cars in the run and they rode on all cars except the one by which they were nominated.

The object of the contest was to ascertain the cost of transporting passengers by automobile. Gasoline consumed was charged at 25 cents per gallon; machine oil, 40 cents per gallon; cylinder oil, 80 cents per gallon;

time of engine and general repairs, 75 cents per hour; new parts, catalogue price; chain repairs, 50 cents per hour, and catalogue price of links. Fines (of which there were none), bridge tolls and ferry charges were included. Repairs on tires were charged as follows:

Time of tire repairs, 50 cents per hour; charges assessed in respect to any occupant of the car who assisted; inner tube punctures, 75 cents; blowouts of inner tubes, 75 cents each; time to inflate inner tubes or replace tubes, 50 cents per hour.

Where the driver carried a mechanic to do repairs on the car, double prices were charged, and this worked against the low score of the Wayne car, as work on it was done by a mechanic and charged for at double rates.

The accompanying table shows the official results of the cars that completed the test:

Order Car.	H. P.	No. of passengers.	Gasoline cost.	Oil cost.	All costs.	Cost per passenger.	Cost per mile.
1 Reo bus.....	16	10	\$16.000	\$3.387	\$29.300	\$2.930	\$.0042
2 Reo	8	4	7.995	.255	13.540	3.385	.0049
3 Compound	15	5	10.875	2.120	18.627	3.725	.0054
4 Wayne	20	5	12.407	2.100	19.815	3.963	.0058
5 Olds	8	4	10.357	.420	15.860	3.965	.0058
6 Compound	15	4	10.342	2.130	17.185	4.296	.0062
7 Marmor	20	5	14.825	1.400	22.915	4.583	.0067
General average...	14½	5	11.828	1.687	19.606	3.835	.0055

UNION PACIFIC MOTOR NO. 2.

"Union Pacific Motor No. 2," is the inscription on the second gasoline motor car which has just been constructed in the big shops of the Union Pacific at Omaha, and which, on its trial trip, glided over the rails at a speed of 57 miles an hour with the ease of a bird and with less jar and noise than is experienced in a Pullman car going at half that speed.

Car No. 1, built last winter and finished in April, was an experiment; Car No. 2 is a commercial success, and apparently demonstrates that its builder is on the way to revolutionize suburban and interurban traffic as well as solve the problem of giving fast and frequent service on branch lines of railroads, thus making money for

No. 1 was driven by a 50 H. P. engine.

No. 2 uses a 100 H. P. engine and No. 3, now under construction, will require a 200 H. P. But No. 3 will be for passengers, mail, express and freight, carrying one or two trailers, and will be a train in itself.

Railroad men from almost every road of any size in the country have journeyed to Omaha to inspect the car, and men of science from all the great laboratories and colleges and workshops have been here to ride in it. Many of the railroads, especially those with large suburban traffic, have asked for terms on which they may acquire some of the new cars for their lines, but as yet the Union Pacific has not had time to build cars for other roads. This is a possibility of the future.

The greatest feature of the car is the

demonstration of the practicability of the gasoline motor as a transportation medium.

At first glance the motor car looks like a big street car. Then points of difference begin to strike the eye. The top of the car looks like an inverted racing yacht. Its lines are such as to offer least possible resistance to the air, and the faster the car runs the harder it is to throw it from the track. The prow is sharp, and the car looks not unlike a flat cigar.

No. 2 has two four-wheeled trucks, is 57 feet long and has a seating capacity of 57 people. Although built entirely of steel, the car weighs only 50,000 pounds, and is said to be 25 per cent stronger than cars weighing twice as much. It has steel sills and bracing, steel carlines and ribs, with angle bracing and outside steel shell.

The trucks are said to be the lightest and strongest ever built and mark a decided advance in the design of passenger car trucks. The wheels are of special rolled steel, of great strength. The driving wheels are 42 inches in diameter and the other wheels 34 inches.

Acetylene gas is used for lighting, and there are 25 opalescent panel lights, mak-

ing the best illuminated car ever built. At the same time the light is of such mild character as not to be wearisome to the eye. It is believed that a large number of branch line railroads now operated at a loss could be put on a paying basis by using gasoline cars instead of steam trains.

Instead of a high-priced engine driver, fireman, conductor and brakemen, as required on passenger trains, two men are all that are required in running a gasoline motor. Instead of a big locomotive eating tons of coal, the new motor uses only about three quarts of gasoline to the mile.

The inventor of the car, W. R. McKeen, Jr., is Superintendent of Motive Power and Machinery of the Union Pacific. He has given much time and thought to transportation problems, and worked on a gasoline motor car many months before he began building one. But so well had he figured that the plans were complete in detail, even to the paint on the car, before work was started. Not one change was made, and although it was an experiment, everything worked just as planned, and the car moved off when the levers were manipulated.—*N. Y. Herald.*

THE NUMBER OF CYLINDERS.

A BRITISH VIEW.

One of the most interesting problems attaching to the construction of motor cars is the settling of the problem as to the number of cylinders which will give the best results. Although makers have been experimenting with a whole range of multi-cylinder motors, a great majority are even yet unable to make up their minds as to what is really the most suitable type for the touring car. They have been experimenting with engines of two, three, four and even up to double that number of cylinders, and, for reasons that are more commercial than technical, have for a long while past been pinning their faith on the four-cylinder engine, to the extent that it is becoming an almost general feature on motor cars, and is even to be seen occasionally on motor cycles.

Where is the tourist with his four-cylinder car who has not had cause to grumble when he found his vehicle jibbing at stiff hills and had to get back on the low speed? Others have hesitated to tour in mountain-

ous countries for fear that their engines would be unable to tackle stiff gradients rising for ten miles or so on end, and it is undoubtedly for this reason that many motorists have not cared to map out their tours to take in such countries as Switzerland or venture across the Alps and Pyrenees, to say nothing of many other charming resorts in Continental Europe, where they would find much to attract them. Consequently when the summer holidays come around many journeys have to be abandoned, simply because the motorist fears that with four or five passengers his car can not be relied upon to negotiate the hilly or bad roads. Rather than have his enjoyment diluted with a constant feeling of uneasiness as to the capabilities of his engine, he prefers to visit touring districts where the roads are known to be good and the grades moderately easy.

No one can deny that whatever power you may have under the bonnet of a touring car, there are scores of incidents in a

daily run to show that even a four-cylinder engine is at times too weak or may develop too much power on intermediate gears. You may throttle or accelerate as much as you will, but you can never get the engine in combination with the gear to accommodate itself exactly to the varying resistances and gradients. Every one who has driven his car in France or in countries where the roads are specially good knows what it is to let the car out with the advance full on and the throttle open. The road runs for miles ahead and can be seen driving straight for the horizon, cutting like a narrow streak between the lines of trees. There seems to be no danger in speed on such a road. The motorist can revel in the fastest speed, with no risk to himself or any one else. The temptation is great. He tries to get every inch of speed out of the car, but, though the vehicle is running well, its speed seems ridiculously low in comparison with what can be safely done on such a road. The same shortcoming is experienced when tackling stiff hills or climbing mountain roads. You have got your lever in the top speed notch, and you are constantly worried with the idea that you will have to change to a lower speed, at which the engine will be tearing its heart out. These are two instances with which every motorist has toured is acquainted, no matter with what make of car. There are, of course, exceptions with high-powered engines, but we are dealing with the touring car generally.

The four-cylinder engine gives excellent results, but is a long way from having the very desirable quality of elasticity. The steam engine has set a high standard in this respect, which the gasoline motor has long been striving to attain. The pioneers of steam cars have always been able to claim advantages on account of the facility with which it will give a full range of power without three or four speed gears. Nevertheless, we are staunch supporters of the internal combustion engine, and the simplicity of the electrically ignited gasoline mixture has not by a long way attained its absolute perfection. The gasoline engine has already secured many advantages formerly claimed as the exclusive attribute of steam, among which may be mentioned silent running. This has been attained by increasing the number of cylinders, and what, with the introduction of mechanically operated inlet valves and with the im-

provements in carbureters, the gasoline engine seems to be on the point of disposing of all arguments left in favor of steam.

While, as I have said, the four-cylinder engine is giving excellent results, it does not need any great perspicacity to foresee the time when the advantage of having a flexible motor will lead makers and users to give more attention to the six-cylinder type. Perhaps this time is not so far distant as some people imagine. It would certainly be a great convenience to be able to fit to cars engines having a regular turning force, so that the torque does not fall so rapidly as it otherwise would do when running at slow speeds, since by such an arrangement it might be possible to dispense with variable speed gears, except to giving high and low speeds. This is no new idea, because I remember that close upon ten years ago there were makers who were trying to devise engines of such flexibility as to reduce the number of gear speeds to two. The advantage of this arrangement would, of course, lie not only in convenience of driving, but also in the greater durability of the propelling mechanism, for the reason that it would be subject to fewer shocks. Many people in France, users as well as manufacturers, have long been trying to work out this problem of giving a fairly constant torque to the engine, so as to be able to reduce the number of gears, and the matter has been given further prominence recently by the successes of Clifford Earp, on his six-cylinder car, at Chateau-Thierry and Dourdan. This six-cylinder British intruder, which dared to cross the silver streak to reap the autumn laurels otherwise intended for the home makers, led these latter to prick up their ears, and consequently we now hear that several other six-cylinder engines will shortly be making their appearance upon the market. In France we learn that Panhard and Levassor, Gladiator, Mutal and other firms are preparing engines of this type, while in America the Pope-Toledo people ran one in the Vanderbilt Cup race. Among British cars fitted with six-cylinder engines we have the Napier, Ariel, Maudslay, Wilson-Pilcher, Brooke, Belsize and Rolls-Royce. If so many makers should have seen that it is to their interest to build engines of this type, it shows that there is an excellent future for motors of this kind. Their advantages are indeed so manifest

that more has not already been done in popularizing the six-cylinder engine.

At the Paris show in 1903, Charron, Girardot and Voigt brought out an eight-cylinder engine, claimed to possess all sorts of advantages, among which was the entire suppression of the change-speed gear, so that all the arguments hitherto put forward in favor of steam, such as silence and elasticity of power, were demolished at a single blow. It is clear that this firm was on the right path; the only mistake they made was in overdoing it, so that the multiplicity of cylinders added greatly to the cost, and the engine took up one-half the frame space—sufficiently serious drawbacks to prevent the employment of eight cylinders. At the same time a low-speed gear could not be conveniently dispensed with for starting under a full load or under certain other conditions when the power of the engine was not sufficient for the weight of the car on steep hills. Seeing that the eight-cylinder engine is a failure, and that the four-cylinder motor does not give quite the needed elasticity, it is only natural that makers should be trying to strike the happy medium with six cylinders, which have, in fact, nearly the same advantages, without the drawbacks, of the famous C. G. V. experimental engine. In the six-cylinder motor there is no dead center to overcome, and the engine suppressing those rasping jerks jerks, so that it is the smoothest running engine turned out. This is a great advantage, since it saves wear and tear on the mechanism, and more especially upon the pneumatic tires, which are given a longer life through the more regular turning of the engine suppressing those rasping jerks on the road wheels, which are one of the causes of the high cost of tire upkeep. It is quite probable that the economy in tires from the use of six-cylinder engines would compensate in a large measure for the cost of the two supplementary cylinders. The absence of dead center opens up all kinds of possibilities in the way of improving the motor car, and it is quite easy to imagine that at no distant date it would be possible to start the motor by the ignition switch from the driver's seat, since one of the charges will be always under full compression. Perhaps it may be necessary to use the starting handle once in the morning when the valves may have got gummed up, but otherwise this automatic starting ought

to present no difficulty with the present six-cylinder engine. In every respect, therefore, we see that the six-cylinder motor is approaching very nearly the convenience of the steam engine. The speed gear difficulty is practically overcome, since the car can be driven at top speed from a standstill up to forty miles an hour and more, if necessary, whereby we obtain results in a simple and practical manner that inventors have been endeavoring to attain for years past with their more or less complicated variable speed gears.

It is, of course, a convenience to have two or even three intermediary speeds, but there may be much less ratio of gears in the gear box compared with those fitted to cars with four cylinders. Under such conditions hills and, for the matter of that, mountain roads, no longer exist. They can be negotiated at the speed one considers best, for by simply opening the throttle any required power can be developed, and it is like admitting more or less steam into an engine, only perhaps in the former case with more immediate and better results. Again, on the level roads that lend themselves to speed all intermediary powers are available by a simple movement of the throttle, and driving becomes as simple as with the steam engine. Does not this six-cylinder motor appeal to the tourist for all-around use at home or abroad when he has to travel over all kinds of roads and on every possible gradient? In my opinion, the six-cylinder car is the car of the future. It at first made a tentative appearance, and has now been experimented with long enough to prove its advantages and to show to those who have been closely following automobile developments that we have now something like an ideal type of engine.—*The Autocar.*

A report from the Consul General at Bangkok, Siam, mentions the field at that place for the power boat. The city of Bangkok has more launches plying upon its waters than any other city in the Orient. These launches are for the most part heavy, clumsy, Chinese-built teakwood boats, fitted with old-fashioned steam engines, burning wood. There is undoubtedly a great future there for the light launch of American make, which ought to be introduced without delay. Engines using kerosene would be the best type, as that can be obtained all over the country.

DENATURIZED ALCOHOL IN GERMANY.

In view of the increasing importance of alcohol as a fuel for internal combustion motors the following information regarding denaturized alcohol will doubtless be interesting to automobilists.

The total output of alcohol in Germany for the year ending August, 1904, was 101,823,470 gallons, by far the greatest part having been produced from potatoes. Comparatively small quantities of spirits distilled from grains, beet molasses, cherries, grape-must, plums and so on were used mainly for drinking and for the manufacture of medicines, perfumes, vinegar and other food preparations. It is the alcohol produced from potatoes, however, that is used for a vast number of industrial purposes, such as lighting, heating and as a motor fuel. The consumption of alcohol in Germany for motor fuel has, however, decreased rather than increased during the past two years, not more than 1 per cent of the total product, or 951,000 gallons, having been used for this purpose during the last year.

Alcohol is used duty free in Germany for industrial purposes after having been denaturized in the presence of a government official. The denaturization, which consists of mixing with the alcohol one or more of the substances prescribed by the very elaborate statutes covering the subject, may be "complete" or "incomplete," according to the purpose for which the spirit is to be used. Complete denaturization is accomplished by adding to every 100 liters (26½ gallons) of alcohol 2½ liters of "standard denaturizer" made of 4 parts of wool alcohol, 1 part of pyridin (a nitrogenous base obtained by distilling bone oil or coal tar), and 50 grains to each liter of oil of rosemary or lavender. A slightly different method consists of adding to every 100 liters of alcohol 1¼ liters of the "standard denaturizer" and two liters of benzol. During the year 1903-4 a total of 26,080,505 gallons of alcohol denaturized by these processes were used for heating, lighting and commercial purposes in Germany.

Incomplete denaturization is employed where the alcohol is to be used for special purposes for which the completely denaturized spirit would be unsuitable. The process is such as to render the spirit unfit for drinking, and varies according to the pur-

pose for which the spirit is to be employed. For instance, for the manufacture of varnishes and inks, the alcohol is denaturized by the addition of oil of turpentine or of animal oil.

Alcohol for the manufacture of soda soaps is denaturized with castor oil. Denaturized alcohol is used in the manufacture of celluloid and pegamoid. Alcohol for the manufacture of ethers, aldehyde, argarcin, white lead, bromo-silver gelatins, photographic papers and plates, electrode plates, colloidion, salicylic acid and salts, aniline chemistry and a great number of other purposes is denaturized by the addition of sulphuric ether, benzol, oil of turpentine, or animal oil.

The quantity of incompletely denaturized alcohol used in Germany last year was 10,277,569 gallons. In addition to the completely and incompletely denaturized alcohol used for the purposes mentioned, 479,138 gallons of pure, for government or public purposes, such as government laboratories, hospitals and for the manufacture of fulminates and smokeless powders.

The cost of producing alcohol in Germany varies with the locality, and also varies from year to year, in accordance with the yield and the consequent market price of the potatoes, grain and other alcohol-producing vegetables. In Prussia during the past year the price of fully denaturized spirits of 90 or 95 per cent strength has ranged from a little more than 32 cents to 45 cents a gallon. During the two years of 1901-2 and 1902-3, when the potato crops were large, there was a great over-production, and the price fell to 15 and 17 cents a gallon cost price, or even less. At the present cost of denaturized alcohol it is anything but an economical fuel for motor use in Germany. In Belgium there are two industries that owe their existence to the fact that denaturized alcohol is not taxed. These industries are the manufacture of ether and of artificial silk, the commodities requiring the annual use of 2,500,000 gallons of denaturized alcohol. Since 1906 the demand for alcohol has increased thirteen-fold, the increase being due principally to the industries mentioned.—*The Automobile.*

FUEL CONSUMPTION TESTS.

A correspondent of an English journal states that, thinking the results of fuel consumption tests might be due to the fact that the cars were specially prepared and in the hands of experts, he commenced on June 4 to put down day by day the exact amount of gasoline put into his car and a record of the places visited and the mileage. The results are as follows: From June 4 to July 25 he covered 1,816 miles. As this was in comparatively flat country, and included very little rough or hilly roads, he gives it separately, as it is interesting to note the difference when the conditions are less favorable. For this 1,816 miles he used 56 gallons of gasoline, which averages $32\frac{1}{2}$ miles to the gallon. From June 4 to September 10 (including the above 1,816 miles) he drove 3,172 miles, that is, roughly, 211 miles per week. He used 110 gallons of spirit, averaging over $28\frac{1}{2}$ miles to the gallon. His car is a standard 12 H. P. Lanchester, and except for jotting down the figures day by day, no special effort was made at gaso-

line economy. He nearly always had a full load of passengers and baggage. The district covered was between Plymouth in the west, Birmingham and Coventry in the north, London in the east, and Brighton and the coast line in the south.

The car is kept mainly for professional purposes. Most of the above represented holiday tours, and except that he kept a boy to wash the carriage work and do the rough jobs, he looked after the car entirely himself. The distances were not checked by means of a cyclometer, but although it would be more satisfactory if they were, the distance from place to place as given in the road book are fairly accurate. He did not bring his record right up to date, because, going to the hill-climbing competition of the Bath Automobile Club, he broke his pump, and the journey back was unfairly extravagant. Then, too, he had to run on an indifferently mended pump for a week or more. The highest weekly run was never above 396 miles, and his lowest was 86.

FLEXIBLE MOTORS.

When a British motor car manufacturer drove a new six-cylinder car 500 miles on high gear, the British motoring public was set to wondering and discussing the feat, for such it really was, considering the condition of the roads and other unfavorable things. Now the discussion has been so prolonged as to raise the question: whether it is not possible to practically do away with change speed gears entirely and depend almost wholly upon the flexibility of the motor for speed governing of the car upon the highways.

It is pointed out that many manufacturers making cars fitted with four speed changes have suddenly taken to advertising the fact that they have motors of great flexibility, indicating that their own cars are capable of being driven long distances without change of gear from the high, and the fact that these concerns have so advertised their wares is pointed out as meaning that they can make flexible motors even of the four-cylinder pattern, and that at

no distant date the cars may be minus the three and four speed change gears, if flexibility of motor is further developed.

This is the argument in favor of six and eight-cylinder motors, but at least one American maker has persistently clung to the manufacture of a car with four cylinders to the motor and with but two changes of speeds in the gear box.

To do away with the multiplicity of speed change gears would doubtless eliminate much complicated mechanism, so far as the speed change portion of the transmission is concerned, but at the same time it would add complications if six and eight-cylinder motors were to come into general use in a desire to obtain flexibility of power. If it is possible for one maker to design a motor with such flexibility as to do away with all save two speed change gears, it is possible for others to do likewise, and this must be the result in time.

It must, however, be remembered that there is a difference in English and Ameri-

can roads, and, while a motor car might be driven for 500 miles without change of gear in England, it would be almost impossible to find 500 miles of roads in America that would permit of such a feat, unless boulevards were depended upon for such a test. Still, the one American make bobs up at all stages of the argument.

It can safely be argued it is not often that great difficulty is encountered in the matter of cylinders, and that there would be little more trouble with six than with four; that it is as easy to take care of a half dozen connecting rods and pistons and commutator parts as two-thirds that number, and that when one cylinder happened out of commission there would be a sufficient number left to do the work on ordinary occasions.

The little controversy which is interesting both English motorists and makers will reach this country before another season passes, and it is safe to say the number of American makers putting out six-cylinder motors, while small today, will be increased at least several fold. Furthermore, it is not beyond an impossibility that ere a very few years have passed the whole transmission scheme will have been so altered as to do away with speed changes entirely, particularly on cars which are of sufficient size to permit them being fitted with motors having not to exceed four cylinders, with which most of the large cars are fitted today. It is a subject which will withstand study and experiment for the next few years.—*Motor Age.*

PREVENTING SMOKE FROM MOTORS.

With increasing numbers of motor vehicles making use of crowded streets, it is of the highest importance that all avoidable inconvenience caused by the escape of unburnt products of combustion should be eliminated. It has been remarked in regard to gasoline vehicles that there is an increasing tendency to diffuse a smoky exhaust, says Edward Butler, in an English journal. It is a thousand pities that this defect should exist at all, since the gasoline automobile—now that its running has been so greatly improved—has become so popular both for business and pleasure, and is steadily winning its way into the favor of the general public.

This regrettable defect in certain cars, especially when unskilfully handled, threatens to prejudice their use, and if allowed to continue it will undoubtedly have the effect of placing other cars which are capable of running inoffensively in a position of great advantage. Yet the nuisance of a smoky exhaust is by no means an inherent factor in the running of a properly made and carefully driven gasoline car. The principal requirement is a scientifically designed method for lubricating the motor cylinders. There may be the most perfect mechanism for speed control and for carbureting the explosive mixture, but if there is a faulty method for lubricating the cylinders a smoky exhaust is bound to follow. The fumes arise entirely from an irregular

supply of oil, and can be remedied by the provision of some suitable means for ensuring a feed proportionate to the necessities of the motor, the cylinders requiring comparatively little lubrication when running "easy," as in the intermittent progress along a crowded street.

In ordinary practice the cylinders are lubricated on the "splash" system, the oil being fed into the crank chamber in regulated quantities, either automatically or by hand, and churned and splashed against the cylinder walls. As a direct consequence of this practice, if a car is slowed down or impeded in its passage, or, worse, if left running empty at the curb side, the oil which has all the time been running into the crank chamber accumulates there, and on opening the throttle and speeding up to the motor the excess oil is splashed up in undue quantities into the cylinders, and, being mixed up with the explosive mixture, becomes vaporized and partially burnt, and so causes a smoky exhaust; this, after a while, rectifies itself automatically, for the motor, if permitted to run at a fair speed, will in course of a block's length or so, use up this accumulated excess supply. This method lends itself to misuse by the driver, who may injudiciously accelerate the feed and overdose the cylinders with oil without taking into account the circumstances of his location. This all tends, of course, to prejudice the motor car in the eyes of the pub-

lic. But it may be stated here that gasoline itself is a highly distilled liquid, that can be used with absolutely perfect combustion, and is in no way to be blamed, although the fault is often attributed to it as the cause of the bad smell and smoke of some unskillfully handled car.

A driver may not always be conscious of proceeding on a smoky exhaust, owing to his position so far ahead of the outlet. A very simple remedy suggests itself for such cases as this, which may consist of a by-pass pipe leading from the exhaust muffler to a point in front of the driver's seat. Any error in the lubrication effect could then at once be detected and means employed for remedying it by immediately draining off the surplus oil or by at once curtailing the supply regularly fed to the engine.

The prevailing tendency is rather to feed too much than too little oil to the cylinders under all conditions; this practice may be harmless enough when traveling in the open country, but in towns it would be much preferable to feed just the requisite amount of oil to the cylinders for the purpose of lubrication, and by so doing leave no chance of excess oil to become vaporized in the exhaust. As a precaution against over-lubrication, the motor should be provided with means for automatically proportion-

ing the supply according to its power and speed, which should again be further reduced in towns to the lowest minimum compatible with the safety of the motor.

In certain better-class cars an over-accumulation of oil in the crank chamber is prevented by overflow outlets; by this means the quantity of lubricant can be instantly controlled to meet the varying requirements of the motor. In others the oil is supplied direct to the cylinders in measured quantities with good results. A very practical method is to fit disked rings under the cylinders for the pistons to dip into, as employed with success on large vertical electric light oil engines; by this means over-lubrication can be made impossible.

The position of the exhaust outlet of gasoline cars is one of the worst for street traffic, as the fumes are puffed out right under the nose of a following horse, and, further, by impinging immediately on the ground, tend to raise unnecessary dust. It would, on this account, be an improvement if the exhaust were conducted away by an outlet in the front of the car, when, if visible, the driver would have the advantage of being able to make the necessary adjustments to avoid a smoky exhaust, which may, under some conditions of traffic and weather, quite conceivably develop into a very serious public nuisance.—*The Motor Way.*

CARBURETERS AND VAPORIZERS.

E. J. WILLIAMS.

There is no use in denying the fact that the carbureter, vaporizer, mixing-valve, or whatever the apparatus may be called that gasifies the liquid fuel, is one of the prime factors or secrets of the efficiency and reliability of the internal combustion engine. There are numerous devices on the market to proportionately mix air and liquid fuel, that give equally satisfactory results, but there appears to still exist a sort of inefficiency as to what should be derived. Their sensitiveness is not always readily adjustable or adaptable to certain makes of engines, and changes of speed and temperature work havoc.

These features are more noticeable with small engines than with the larger ones.

Compensating carbureters are the latest moment toward perfection, but the selling price has soared to extraordinary height.

Foreign manufacturers are also concentrating their attention along this line of automatic regulation, by using an auxiliary air port on the carbureter. This port is opened and closed according to the engine speed, manipulated automatically through the medium of a diaphragm, or a piston arranged in connection with a float in a mercurial suction tube, arranged in combination with the induction pipe. Another form utilizes a diaphragm manipulated by the pressure attendant upon the water pressure of the circulating water at different speeds.

These principles are all in an endeavor to produce a uniform ignitable mixture at all speeds and positions of the throttle. In action the auxiliary air port is closed in starting, and as the throttle is opened produces more speed, and consequently more suction, the auxiliary port gradually opens

as the speed increases, admitting the proper amount or proportion of air to mix with the gasoline vapor.

Upon the perfection of the carbureter frequently lays the secret of the gasoline or internal combustion engine's proper or maximum flexibility in its present form of design. The 2-cycle engine since its advent has been dependent upon a generator valve or vaporizer, until the 3-ported type came into the field, which permits of the use of a carbureter without a check-valve, although some makes of 3-ported engines are occasionally found fitted with a check-valve vaporizer.

The 2-cycle 3-ported engine carbureter, it appears, is not compensating on the smaller size, and to hear the engine speed up and give a forlorn puff for want of a more uniform mixture, shows very plainly the need of some attention toward a better type of mixing apparatus for this special type of engine. To make the 2-ported, 2-cycle gasoline engine sell within a price favorable to all, the vaporizer is yet a noticeable feature, and the cause of most of the trouble consistent with this type.

When the spark is of the best, set properly, points clean, proper flow of gasoline, no leaks in crank-case or cylinder, and with a good compression, it is hard to understand what else, other than the vaporizer, is the cause of failure to start, after trying needle-valve on all points, and the crank-case not flooded. The needle-valve requires to be of the proper shape, of course, and seldom is it subject to injury, but the check-valve seat wears incessantly and requires grinding in at regular periods.

Not considering any foreign substance in the gasoline, vaporizers have the reputation of causing a great deal of trouble to power boat operators.

The majority of float-feed carbureters have a needle-valve working in conjunction with the throttle, so that the quantity of fuel admitted through the spraying nozzle is kept at nearly the proper proportions at the various positions of the throttle lever. The needle-valve is locked to the throttle spindle on the outside of the carbureter, after it is found in what position the valve must be set in starting. This adjustment is occasionally done by the manufacturer, but more often by the purchaser.

It has been found advisable to warm the air entering the carbureter or vaporizer, but not to an extreme degree. Carburation is a cooling process, and carbureters have been known to freeze up. The colder the air, the more power to be derived, owing to a larger volume of gas entering the cylinder, due to its contraction, while if the gas is warm, it has expanded somewhat and a less amount enters, but carburates easier and permits a more uniform temperature of air to enter the induction pipe.

Carbureters that give good service on land in the open air do not always give the same good service for marine use. The different types are generally designed for use with automobile engines, and eventually come into service with the marine engine. It seems as if attention could be diverted toward developing a carbureter, designed especially for marine engines.—*Power Boat News.*

A HOT GASOLINE ENGINE.

BY W. W. CLAYTON.

Having bought a mounted engine, shipped complete from factory and set up, customer wires, after having tried two days to make it operate:

"Engine runs 30 minutes, then stops. If our fault, we pay man's expenses; if engine's fault, you pay."

Thinking this a fair deal, we sent a man out. He found they understood all the principles of the working parts and the sparking apparatus. He told them to start her up, and sat down to watch developments. In about twenty minutes the en-

gine stopped, solely on account of piston swelling, due to excessive heat. On investigation the water in the tank was cool. Waiting some time before starting to work, to give the engine a chance to cool a little (for fear of cracking cylinder jacket by applying cold water), he took the water pipes apart and found some malicious employee at the factory had stuffed a rag in one of the nipples in the top outlet water connection from cylinder to water tank, and drove it in, then put cement on each end of the rag so it would hold. "We paid."

A 400 H. P. RACING GASOLINE POWER BOAT.

Great interest is being manifested among naval and marine engineers in Great Britain in the gasoline motor racing boat built by the Brooke Motor Company, of Lowestoft. This craft, although primarily designed for racing purposes, is yet of substantial construction, so that it may be possible of utilization in a seaway. The boat, which is propelled by a 400 H. P. engine, is one of the most powerful craft of its type that has yet been constructed.

The boat is just under 40 feet long, with an extreme breadth of 5 feet 6 inches. The

of Oregon pine and two side stringers of slightly smaller scantling are fitted at each side, extending and tapering to the end of the boat. A heavy gunwale of American elm completes the longitudinal distribution of the wood construction. The transverse strength is attained by timbers of selected American elm, considerably augmented by grown oak floor frames, all well molded at their throats and all carried hard up to the bilge stringers at each side. Although the strength of the hull as described above is by no means inadequate, yet it has been in-

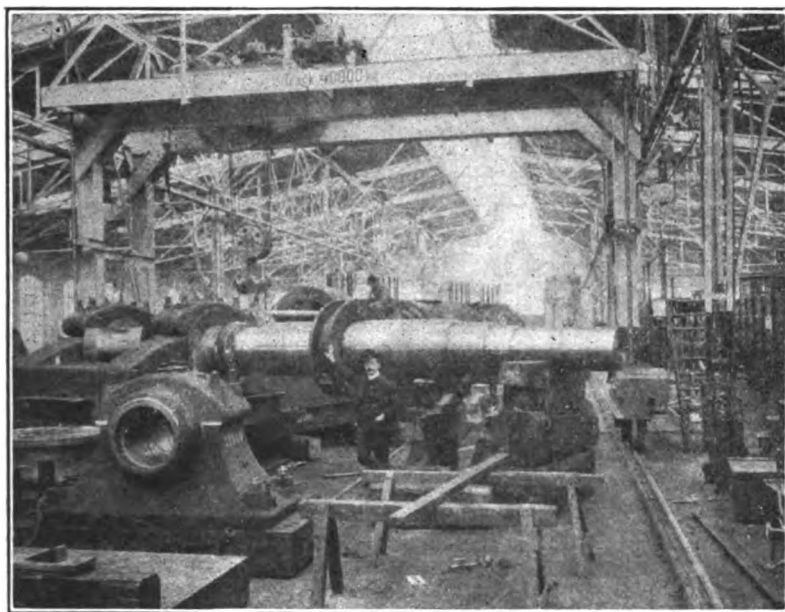

Crankshaft of 1200 H.P. Nurenburg Gas Engine, weight, 55 000 pounds diameter, 24 in.

draft at the greatest immersed section of the hull is only 12 inches. In view of the enormous power this launch possesses, and with regard to other conditions, great attention has been devoted to the questions of strains due to propulsion, pounding in a seaway, etc., in the design of the hull.

The motor supports are of ample strength and extend the full length of the launch. In conjunction with the American elm keel, they form a substantial backbone to the whole fabric, giving great longitudinal strength and affording a solid foundation for the 400 H. P. motor. A bilge stringer

is creased by the addition of steel angle-bars, stringer plates, and tie angles. The fore part of the boat, as well as the rest of the hull, is fitted with steel frames supplemented with beams or cross-tie angle-bars. These frames are very necessary at this part of the hull, for racing launches of high speed and light draft are subject to severe panting stresses and thumping under the bows, as their enormous propelling power drives them into head seas, and they may, unless properly stiffened, bulge in the frames and planking at this locality.

While the diagonal lines of the boat are

long and narrow, showing just a slight roundness as they extend from bow to stern, the underwater body has been made fairly flat, merging into a nicely rounded bilge, which in its turn is gradually lost as it approaches the transom. She has been given a very fair freeboard, combined with a good fore turtle deck, insuring ample protection in any ordinary weather, and for negotiating bad weather a light portable structure is fitted over the well, with a small aperture aft for the steersman.

The engine is of the vertical, six-cylinder type, the cylinders cast separately, thereby greatly facilitating their accessibility. The bore is 10 inches, the stroke 8 inches, and at the normal speed of 1,000 r. p. m. the nominal 400 H. P. is developed.

The cylinders are water-cooled, the jackets being cast with the cylinders. Two entrances are provided in each jacket for the circulation of the cooling water, above the combustion chamber and the exhaust valve. The induction valves are arranged on the starboard side of the engine and are of large diameter with angular seats, and are set down below the main level of the water. The exhaust valves are placed on the opposite side of the engine, and are interchangeable with the inlet valves. By slightly sliding the camshaft operating the exhaust valves, the latter are caused to lift on the compression stroke to facilitate starting. The inlet and exhaust crankshafts are driven by large outside two-to-one gear wheels, and to insure perfect alignment are run in seven bearings each.

The crank chamber, which is made of cast steel, is formed of two sections, and is provided with six large inspection doors on each side. The crankshaft runs in five intermediate bearings on bored surfaces, and the bolts securing them to the bottom of the crank case extend up through the top of the same, in order to act as the holding down bolts of the cylinder heads. Two types of ignition are available—low-tension magneto and the high-tension system with accumulators and coil.

Splash lubrication is adopted for the lower ends of the connecting rods and intermediate bearings. The gudgeon pins and pistons are provided with a light flywheel carrying an expanding internal metal-to-metal clutch, which transmits the engine power through universal joints, reverse gear, and thrust block to the propeller.

The design of this boat, in which the aim has been to secure the maximum of strength consistent with the minimum of weight, and the high power of the motor, have provoked much discussion in marine engineering circles, and the behavior of the craft in varying weather conditions is being awaited with profound anticipation. It is conceded that this launch provides an interesting development of the application of gasoline engines of great horsepower to small, light hulls, and the results of its trials will exercise a far-reaching effect upon the design of this class of craft for various purposes where large horsepower, speed and light hulls are required.—*Scientific American*.

PRODUCER GAS FROM INDIANA COAL.

The Marietta Glass Company, Sixteenth street and Sherman drive, Indianapolis, Ind., is now in operation, using, to take the place of coal, producer gas made from Indiana coal. This gas costs the company from 6 to 7 cents per thousand cubic feet, and has proved very satisfactory.

When interviewed concerning the matter, Mr. Butler, President of the company, made the following statements:

"We hear a great deal about the relative heating power of producer gas and natural gas. Some say that producer gas runs but 200 heat units, while natural gas runs from 960 to 1,300; or, in other words, that nat-

ural gas is five or six times as hot as the producer gas, but we do not care about that. We know this, that we have used natural gas up at Redkey at 8 cents per 1,000 cubic feet, and that we can produce just as much glass here for the same money invested in coal, made into producer gas, as we could with the natural gas at that price.

"Both have certain disadvantages. For instance, the producer gas that we make and use is only raw gas, and is very dirty, and it clogs up the pipes so that we have to burn or clean them out once a week. But the natural gas was uncertain in winter, and

often the pipes would freeze up, and we were always confronted with the fact that it was giving out and was going to go out entirely. We know that we can make this gas as long as Indiana produces coal, and it gives us the assurance of permanency."

This is not the only company that is using producer gas for fuel. There are a number of Indiana manufacturing firms that are being operated with this raw gas, it being preferable to coal used direct, on account of the resultant economy.—*The Inland Operator*.

INDUSTRIAL ITEMS.

Gas Engine Whistle Co., 1133-B Broadway, New York, have recently been incorporated with capital of \$10,000.

The Benedict Manufacturing Company, to make gas and gasoline engines, has been formed, and will establish a plant in Salamanca, N. Y.

The Power Co., Limited, have been incorporated at Hampton, N. B., with a capital stock of \$20,000, to manufacture gas engines, etc.

The Niagara Engine Works Co., Niagara-on-the-Lake, Ont., have been incorporated with a capital of \$50,000, to manufacture gas and gasoline engines, etc.

The Toledo Motor Boat & Power Company, of Toledo, capital \$10,000, has been incorporated by Ernest Pauck, Charles R. Messinger, Harry B. Kirtland, R. S. John and J. I. Roche.

The Joseph Reid Gas Engine Company, Oil City, will build a new foundry, 85x225 feet in size. The foundation for the building will be of concrete and that portion bordering on the river is 18 feet high.

The Standard Power Gas Construction Corporation, Limited, Toronto, have been incorporated with a capital stock of \$100,000, to manufacture gas, gasoline, electric and other power engines and machinery, etc.

One of the schools for teaching gas engine and automobile subjects is the Rochester, N. Y., Athenaeum and Mechanics Institute. Prof. Allen S. Crocker is in charge of this department and the students are given instruction in the care and operation of this type of engine.

The Havana Mfg. Co., Havana, Ill., has succeeded to the business of the Ashurst

Press Drill Co., and has improved and increased the old facilities for handling the business. The company makes the "Red and Ready" and "Havana" line of gas and gasoline engines and the Havana double-grip friction clutch pulley.

Permanent organization has been effected by the Hicks Gas Motor Company of Waycross, Ga., which incorporated some time ago with a capital stock of \$250,000. This company will erect a 50x100 foot building and install modern machinery and tools for the manufacture of a new stationary and marine gasoline engine, motors, etc., in accordance with the inventions and patents of J. B. Hicks, who will be manager of the company.

Some changes have been made in the organization of the Western Gas Engine Company, Los Angeles, Cal. Mr. W. H. Frost is now President and general manager, and Mr. R. B. Sumner is Secretary of the company. On account of illness, Mr. E. A. Guthrie, formerly President, has been obliged to retire from the business.

"Crankshafts and Their Bearings" was the subject of discussion at the November meeting of the mechanical branch of the Association of Licensed Automobile Manufacturers, held in New York, November 1. Various members of the organization, superintendents from the factories of representative manufacturers, exhibited drawings of their crankshaft construction, and, after giving all the dimensions, telling the pressure on the bearings, the material used, methods of construction, of lubricating, etc., answered such questions as the others chose to put. The subject for the December meeting will be the best method of inspecting and testing cars, so as to be certain that they are all right before shipping them from the factory to the branches and agencies.

TRADE PUBLICATIONS.

"Jump Spark Coils" is the title of a very neat catalogue of The Tritt Electric Co., Union City, Ind.

Circular 88 of the Backus Water Motor Co., Newark, N. J., shows the Backus suction gas producer.

Catalogue 14 of the Springfield Gas Engine Co., Springfield, O., gives complete information regarding a friction clutch pulley for use on gas and gasoline engines.

The first 1906 calendar to reach us is a reminder from the Springfield Gas Engine Co., Springfield, O., and is a small one of letter envelope size and shows "The Girl in Red."

Bulletin No. 9 of the National Engineering Co., Bradford, Pa., contains some interesting information regarding gas engine driven electric light plants, utilizing storage batteries.

Perfect synchronism and a practical distributor, perfectly synchronized, are the subjects of two interesting circulars from C. L. Altemus & Co., The Bourse, Philadelphia, Pa.

Bulletin No. 131 of the Dayton Mfg. Co., Dayton, Ohio, shows in addition to the storage batteries of previous bulletins of this company, a new type for supplying current for gas and gasoline engines.

The Olds Gasoline Engine Works, Lansing, Mich., will in the future, issue their catalogues in bulletin form. Bulletin No. 1 is received and fully describes and illustrates the type a Olds engine.

Beaver gas and gasoline engines are made in units of $3\frac{1}{2}$ and $6\frac{1}{2}$ H. P., by the F. Beaver Machine Co., 220 E. Second St., Cincinnati, Ohio, who have recently issued a catalogue giving full details.

A circular from the M. O. Cross Engine Company, Detroit, Mich., shows their line of engines, and particularly their newest unit, a small marine engine, designed especially for small boats of about 20 feet.

A circular from G. & C. Merriam Co., Springfield, Mass., describes the additions and revisions of the latest edition Webster's international dictionary. There have been included 25,000 new words and phrases.

"Has Gasoline Sounded the Knell of Steam?" This is the title of a booklet of the Perkins Wind Mill Company, Mishawaka, Ind., and, of course, the Perkins gas and gasoline engine enters into the answer to the question.

"Gas Power Excellence" is the title of a well-illustrated and well-printed catalogue of the Angola (Ind.) Engine and Foundry Company. Several circulars are also distributed by this company relative to special sizes and types of engines.

The Challenge Company, Batavia, Ill., has just issued a very good catalogue of the Challenge gas and gasoline engines. Very fine half-tones, showing completed engines and parts, add much to the value of the catalogue to the prospective customer.

The Schug Electric Mfg. Co. of Detroit, recently moved to 48-54 Champlain St., and a circular issued by them shows the excellent facilities which they now enjoy. An "advance sheet" from the same company shows their line of coils, etc., gives diagrams for wiring coils, and batteries, and includes some excellent testimonials from users.

The Culver (Ind.) Novelty Company has a small catalogue of Young's rotary carbureter and mixer. This carbureter, which may be applied to any class of engine—stationary, marine or automobile—utilizes two oppositely rotating wheels, with inclined vane-like blades, to assist in the work of vaporizing and mixing the gasoline and air.

Bulletin 29 of the Holliday Mfg. & Engineering Co., 160 Bunker St., Chicago, Ill., shows a line of marine engines and equipment. A special feature is the type of reversing clutch which is used. Another feature of the catalogue is a table showing the measurement of many of the important dimensions of the engines.

GENERAL INDEX

- Agricultural Motor, a British..... 23
 Agricultural Purposes, Motors for..... 191
 Air Cooling for Motor Car Engines..... 25
 Alcohol as a Fuel for Motors..... 218, 260, 402
 Alternating Current Electric Traction..... 21
 Answers to Inquiries..... 49, 81, 115, 142, 174, 207, 249, 279, 334, 351
 Anti-Fluctuator, Gas Pressure..... 107
 Anti-Freezing Mixture, Wood Alcohol as an..... 61
 Application of Gas Power to Electric Railway Service..... 363
 Automatic Carbureters, Clutches and Brakes..... 259
 Automatic Gas Producer..... 382
 Automobile Handbook (Book Review)..... 177
 Automobile Pocketbook..... 88
 Automobile Department..... 22, 54, 84, 120, 148, 183, 217, 251, 287, 325, 361, 397
 Automobile Transportation in Mining Districts..... 258
 Automobiles and Motor Boats in China..... 208
 Automobiles for Dry Goods Merchants..... 128
 Automobiles for Europe..... 144
 Automobiles for Laundries..... 127
 Auxiliary Exhaust, Possibilities of..... 362
 Ball Bearing Crankshaft..... 226
 B. and C. Friction Clutch Pulley..... 32
 Blast Furnace Gas..... 209
 Blast Furnace Gas, Cleaning of..... 206
 Books, Recent..... 113
 Book Reviews..... 42, 145, 177, 228, 262, 298, 315
 Brake Capacity, Prony..... 315
 British Agricultural Motor..... 23
 British Coal Supplies..... 132
 California Gas & Electric Corporation, 5,000 H. P. Gas Engines for..... 342
 Canadian Import Figures..... 352
 Canal Boat, Motor Propelled..... 264, 286
 Canoe, Successful Motor..... 18
 Carbureters..... 90, 184
 Carbureters and Vaporizers..... 405
 Care for Your Engines..... 377
 Cheaper Gas for Power in Birmingham..... 283
 Chicago Automobile Show..... 85
 China, Motor Boats and Automobiles in..... 208
 Circus and the Gasoline Engine..... 173, 269
 Cleaning of Blast Furnace Gas..... 206
 Clifton Marine Engines..... 313
 Coal Mines Gas and Gasoline Engines for..... 83
 Coke Gas Producer, A..... 165
 Combustion Sight-Hole, A..... 316
 Commercial Motor Car Problem..... 28
 Commercial Vehicles, Gasoline Engines for..... 189
 Compression..... 221
 Compression, a High, Gas Engine..... 216
 Compression, Effect of Hydrogen on..... 358
 Coney Island, N. Y., a High Pressure Water System for..... 246
 Continental Engines..... 89
 Continental Gas Engines, Growth of Large..... 232
 Cooled, Why Cylinders Must Be..... 125
 Cooling Water Arrangement for Gas Engines..... 319
 Correspondence..... 43, 841, 378
 Cost of Natural Gas Operation..... 2
 Cost of Operation..... 296
 Cylinders, The Number of..... 399
 Cylinders, Why they Must be Cooled..... 125
 Dean Gas Engines..... 117
 Decision Involving Horsepower..... 171
 De Dion Engine Dimensions..... 338
 Denaturalized Alcohol in Germany..... 402
 Designer Shown in His Engine..... 270
 Development of the Gas Engine..... 106
 Development of the Industrial Motor..... 227
 Difference of Theory and Practice..... 228
 Dry Batteries (Book Review)..... 42
 "Echoes from the Oil Country"..... 211
 Economy Test, Results of..... 398
 Editorial..... 1, 35, 67, 101, 131, 161, 195, 231, 267, 303, 339, 375
 Effect of Hydrogen on Gas Engine Compression..... 358
 Efficiency of Gas Engines..... 204
 Efficiency of the Gas Turbine..... 19
 Electricians' Handy Book (Book Review)..... 298
 Electric Ignition Applied to Internal Combustion Motors..... 40
 Electric Light Outfits..... 11, 48
 Electric Railway Service, Application of Gas Power to..... 358
 Electric Sparking for Explosive Motors..... 96
 Ender Clutch Pulley..... 387
 Engine Braking..... 365
 English View of Air Cooling for Motor Car Engines..... 25
 Enlargement of Rockland Gas Engine Plant..... 396
 Etna Green, Ind., Lighting Station..... 384
 European Tendencies, Some..... 252, 288, 326
 Excelsior Spark Plug..... 371
 Experience..... 184
 Factors in Gas Engine Development..... 200
 Fairbanks-Morse Suction Gas Producer..... 110
 Farm Use of Gasoline Engines..... 53
 Fire Engine, Gasoline Propelled..... 60
 Fishing Schooner, Scotch..... 349
 Five Thousand Horsepower Gas Engines of the California G. & E. Cor..... 342
 Flexible Motors..... 403
 Fly Wheel Formula, A..... 309
 Fogs Gas Engines..... 170, 276
 Fox's Reversible Engine..... 160
 Foundations, Sounding for Bridge and Dam..... 238
 Four Cycle vs. Two Cycle Gas Engines..... 4
 Fuel Consumption Tests..... 403
 Fuel Getting to the Gas Engine..... 63
 Gas as a Motive Power and Its Relative Cost..... 322
 Gas and Gasoline Engines for Coal Mines..... 83
 Gas Driven Country House Electric Light Installation..... 389
 Gas and Oil Engines in Sweden..... 250
 Gas Driven Locomotives and Ships..... 94
 Gas Engine Accidents..... 244, 348
 Gas Engines and the Steam Turbine..... 244, 348, 263, 263, 145
 Gas Engine Design (Book Review)..... 106
 Gas Engine, Development of the..... 259
 Gas Engine Output, Some European..... 360
 Gas Engine in Practice..... 167
 Gas Engine Inquiries..... 393
 Gas Engine Driven Railway Station..... 36
 Gas Engine Pumping Plants..... 297
 Gas Engine Sounds..... 9
 Gas Engine Theory and Practice..... 37
 Gas Engine Troubles..... 8
 Gas Engine Specifications..... 181
 Gas Engine Weight and Speed..... 141
 Gas Engine Wrinkle, A..... 315
 Gas Engines and Launches (Book Review)..... 280
 Gas Engines at Portland..... 145
 Gas Engines and Producer Gas Plants (Book Review)..... 390
 Gas Engines, Design of Large..... 75
 Gas Engines for Factory Power..... 393
 Gas Engines for Large Vessels..... 53
 Gas Engines for Warships..... 118
 Gas Engines for Water Works Service..... 135
 Gas Engines in the Army and Navy..... 71
 Gas Engines in Ice Cream Factories..... 168
 Gas Engines in the Blacksmith Shop..... 134
 Gas Engines, Recent German..... 136
 Gaseous Fuel, Power Production from..... 39, 273
 Gas for Power..... 70
 Gas from Vegetable Products..... 271
 "Gas News"..... 299
 Gas Power Plant, A..... 165
 Gas Producer, A Coke..... 804
 Gas Producer Plant, An Indiana..... 240
 Gas Producer Power Plants..... 228
 Gas Producers for Power Purposes (Book Review)..... 274
 Gas Producers, Underwriters' Regulations for..... 29
 Gas Producers, Wile..... 19
 Gas Turbine, Efficiency of the..... 77, 285
 Gas Turbine, The..... 380
 Gas vs. Gasoline Engine..... 379
 Gasoline and Naphtha Engines..... 47
 Gasoline and Oil Engines Abroad..... 263
 Gasoline and Water Separator..... 278
 Gasoline Driven Rock Drill, A..... 269
 Gasoline Engine and Compressor..... 169
 Gasoline Engine and the Circus..... 31
 Gasoline Engines in China..... 352
 Gasoline Engines in New Orleans..... 347
 Gasoline Engines in the Dairy..... 121
 Gasoline Engines on the Farm..... 199
 Gasoline Engines, Testing of..... 362
 Gasoline Engines for Commercial Vehicles..... 362
 Gasoline Engine Piston..... 362

Gasoline Engine Repair Job.....	370	Price vs. Quality.....	276
Gasoline Propelled Fire Engine.....	60	Producer Gas (Book Review).....	178
Gasoline Propelled Railway Cars.....	222	Producer Gas from Units.....	179
Getting Fuel to the Gas Engine.....	68	Producer Gas from Indiana Coal.....	408
Goodson Ignition System.....	424	Producer Gas from Tests at St. Louis.....	261
Gordon Battery Improvements.....	324	Producer Gas vs. Gasoline in Mine Holsts.....	318
Gordon Bennett Race.....	264	Producers, Underwriters Regulations on.....	274
Government Investigation of Gas Engines.....	281	Production of Power Gas.....	281
Growth of Large Gas Engines on the Continent.....	234	Progress of the Gas Engine.....	157
High Pressure Water System at Coney Island, N. Y.....	246	Prony Brake Capacity.....	315
Hot Gasoline Engine, A.....	406	Quick Automobile Delivery.....	367
Hydrogen, Effect on Compression.....	358	Quick Repair, A.....	300
Ice Cream Factories, The Gas Engine in.....	71	Railway Car, Self-Propelled.....	125, 222, 398
Ignition, Electric, Applied to Internal Combustion Motors.....	40	Railway Motor Car.....	153
Ignition System, The Goodson.....	46	Railway Station, Gas Engine Driven.....	393
Ignition Timers, Two.....	45	Reachless Double Spring Gear.....	65
Ignition Troubles.....	370	Reasoning Gas Engine Operator, The.....	162, 340
Implement Dealers and the Gasoline Engine.....	320	Recent Books on Gas Engines and Automobiles.....	113
Indiana Gas Producer Plant, An.....	304	Recent German Gas Engines.....	124
Industrial Items.....	34, 66, 100, 130, 300, 337, 373	Relative Advancement of Spark Systems.....	214
Installation Notes from Everywhere.....	197	Results of Economy Test.....	398
Installing Gasoline Engines.....	295	Rock Drill, a Gasoline Driven.....	203
Insurance Regulations on Gas Producers.....	274	Rockland Gas Engine Plant Enlargement.....	396
Internal Combustion Engines at Key West.....	21	Salt Water for Cooling.....	263
Is Gas Power More Economical than Water Power?.....	356	Scotch Engine and Producer Tests.....	275
Items.....	64, 92, 159, 193, 206, 266	Scotch Fishing Schooner.....	349
Jacobson Gas Engine.....	121	Scotch Gas Engine Tests.....	202
Jump Spark Coil Suggestions.....	215	Self-Propelled Canal Boats in Ohio.....	286
K. and D. Igniter.....	227	Shipping Portable Gasoline Engines.....	199
Kingston Automatic Carbureter.....	154	Ships, Gas Driven.....	94
Knabenshue's Airship.....	332	Shortage of Gasoline, Threatened.....	114
Large Gas Engine Work Some.....	80	Sight-Hole, A Combination.....	316
Large Gas Engines, Design of.....	390	Smith Gas Producer, The.....	201
Large Gas Engines on the Continent, Growth of Launch Gregory, The.....	234, 284	Smoke from Motors, Preventing.....	404
Laundries, Automobiles for.....	127, 13	Some Common Troubles and Remedies.....	363
Laying Telephone Cable.....	13	Some European Tendencies.....	252, 288, 326
Length of Motor.....	220	Some Gas Engine Accidents.....	244, 348
Liege Exhibition, Some Gas Engines at the.....	246	Some Gas Engine Troubles.....	37
Lifboats, Motor.....	102	Some Gas Power Tests.....	198
Locomotives, Gas Driven.....	94	Some Large Gas Engine Work.....	80
Marine Gas Engine, The.....	100	Some Recent English Inventions.....	323
Marine Propulsion, Past, Present and Future of McClelland Oil Purifier.....	146, 333	Sounding for Bridge and Dam Foundations.....	238
Mechanical Efficiencies of Internal Combustion Motors.....	317	Spark Advancement, Relative.....	214
Mechanical Efficiency of the Gas Engine.....	247	Spark Plug Users, Suggestions to.....	44
Mine Holsts, Producer Gas vs. Gasoline in.....	318	Special Generators for Gas Engines.....	210
Modern Two-Cycle vs. Four-Cycle Gas Engine Plants.....	4	Specifications, Gas Engine.....	8
Motor Boat Fallacies.....	263	Speed and Weight of the Gas Engine.....	161
Motor Boat Papers.....	27	Speed Limit in Gas Engines.....	149
Motor Boat Rating.....	128	Steam Turbine and the Gas Engine.....	263
Motor Boats and Automobiles in China.....	208	Stopping Tests.....	226
Motor Boats in Australasia.....	386	Sulphur as a Packing Between Bed Plates and Foundations.....	209
Motor Car in English Laundry Service.....	224	Sweden, Gas and Oil Engines in.....	250
Motor Car, Railway.....	153	Telephone Cables, Laying.....	13
Motor Launch; How to Build and How to Run Them (Book Review).....	228	Testing of Gasoline Engine.....	121
Motors and Motoring (Book Review).....	262	Tests, of Producer Engine and Pump.....	285
Motors for Agricultural Purposes.....	91	Thermal Efficiency of Modern Motive Power Engines.....	73
Motors for Boats in Western Norway.....	205	Tests, Some Gas Power.....	198
Naphtha and Gasoline Engines.....	72	Tests, Some Scotch Engine and Producer.....	275
Narrow Escape, A.....	396	Threatened Shortage of Gasoline.....	114
National Motor Boat and Sportsmans Show.....	104	Traction, Alternating Current Electric.....	21
New-Dur Exploder, The.....	78	Trade Publications.....	33, 63, 97, 129, 410
New York Show, Mechanically Considered.....	55	Troubles and Remedies, Some Common.....	363
New York Show, Notes on the.....	57	Troubles, Some Gas Engine.....	37
Non-Freezing Solutions.....	339	Turbine, The Gas.....	77, 285
Notes from England on Gas Power.....	381	Two-Cycle Air Cooled Engine.....	293
Notes from Everywhere.....	277	Two-Cycle vs. Four-Cycle Gas Engine Plants, Modern.....	4
Notes on the Thermal Efficiency of Modern Motive Power Engine.....	73	Two Ignition Timers.....	45
Number of Cylinders, The.....	399	Ultimate Limit of Speed in Gas Engines.....	149
Oil Engines, Marine.....	14	Underwriters' Regulations on Gas Producers.....	274
Oil in the Gas Engine Cylinder.....	314	Union Pacific Motor No. 2.....	395
Operating Large Gas Engine in Cold Weather.....	109	Useful Gas Engine, The.....	77
Paris Automobile Show, Some Tendencies of the Past, Present and Future of Marine Propulsion Patience With the Gasoline Engine.....	86, 146, 311	Vaporizers and Carbureters.....	405
Peat Gas for Gas Engines.....	3	Vegetable Products, Power Gas From.....	70
Picking Cotton by Gasoline Engine.....	182	Vertical Motor, How to Examine.....	53
Piston, The Gas Engine.....	368	Warships, Gas Engines for.....	53
Portable Gasoline Engines, Shipping.....	190	Water and Gasoline Separator.....	47
Power for Light Manufacturing from Suction Gas Producers.....	343	Water Power, Is Gas Power More Economical?.....	356
Power Gas.....	175	Water Works Service, Gas Engines for.....	118
Power Gas from Vegetable Products.....	70	Weight and Speed of the Gas Engine.....	171
Power Production from Gaseous Fuel.....	136	Western Gas Engine.....	156
Pressure Anti-Fluctuator, A Gas.....	107	Western Two-Cycle Engine, The.....	213
Preventing Smoke from Motors.....	404	"What Caused the Gasoline Engine to Stop?" What Should He Have Paid?.....	394, 172
		Why Cylinder Must Be Cooled.....	125
		Wile Gas Producers.....	39
		Wind Mills and Gas Engines.....	41
		Wood Alcohol as an Anti-Freezing Mixture.....	61
		Wood Gas for Gas Engines.....	17
		Wood Gas for Power.....	235

Special Clubbing List.

Offer No.		Regular Price.	Clubbing Price.
10	{ The Gas Engine, one year - - - -	\$1.00	\$3.50
	{ The Gas Engine Handbook - - - -	1.50	
	{ Gas Engine Troubles and Remedies -	1.00	\$2.50
11	{ The Gas Engine, one year - - - -	1.00	\$2.50
	{ The Gas Engine Handbook - - - -	1.50	
12	{ The Gas Engine, one year - - - -	1.00	\$2.00
	{ Gas Engine Troubles and Remedies -	1.00	
15	{ The Gas Engine, one year - - - -	1.00	\$3.50
	{ How to Build a 3 H. P. Launch Engine (Blue Prints, \$4.00 extra) - - -	2.50	
16	{ The Gas Engine, one year - - - -	1.00	\$6.00
	{ The Gas Engine Handbook - - - -	1.50	
	{ Gas Engine Troubles and Remedies -	1.00	\$4.00
	{ How to Build a 3 H. P. Launch Engine (Blue Prints, \$4.00 extra) - - -	2.50	Blue Prints, \$4.00 Extra.
17	{ The Gas Engine, one year - - - -	1.00	\$2.00
	{ Suction Gas - - - - -	1.00	

Descriptions of the books will be found on other pages of this issue.

Send for copy of our book catalogue, 200 books listed.

The Gas Engine Publishing Co.,

54 Blymyer Building, CINCINNATI, OHIO.

Bullock

Bullock

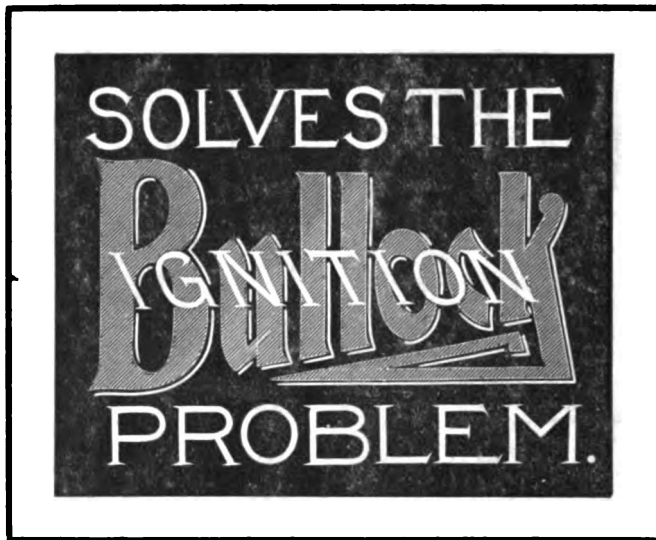

Bullock

The Bullock-Beresford Manufacturing Co.
CLEVELAND, OHIO.

Bullock

Engines for Auto Boats

LIGHT

POWERFUL

DURABLE

Any Number of Cylinders

Designed for Manufacturers or Private Parties

Do Not Experiment

Profit by Experience

E. W. ROBERTS, M. E.,

Box 321.

CLYDE, OHIO.

FEB 9 1905

ASTOR, LENOX AND TILDEN FOUNDATION

BEAU DE ROCHAS 1862

CLERK

BRAYTON

HUGON

BARSANTI

MAFFIENILLE

BUYCHERS

ATKINSON

OTTO

LENOIR

MATTECCI

BARNETT

PAPIN

THE GAS ENGINE

A MONTHLY MAGAZINE

Devoted to the interests of the
GAS-ENGINE INDUSTRY

STATIONARY · AUTOMOBILE · MARINE

FEBRUARY, 1905

CONTENTS

GAS ENGINE PUMPING PLANTS	36
SOME GAS ENGINE TROUBLES	37
GAS FOR POWER	39
ELECTRICAL IGNITION APPLIED TO INTERNAL COMBUSTION MOTORS	40
CORRESPONDENCE	43
WINDMILLS AND GAS ENGINES	44
SOME SUGGESTIONS TO SPARK PLUG USERS	44
TWO IGNITION TIMERS	45
THE GOODSON IGNITION SYSTEM	46
GASOLINE AND WATER SEPARATOR	47
ELECTRIC LIGHT OUTFITS	48
ANSWERS TO INQUIRIES	49
TESTS FROM FOREIGN EXCHANGES	52
FARM USE OF GASOLINE ENGINES	53
GAS ENGINES FOR WARSHIPS	53
AUTOMOBILE DEPARTMENT	54
THE SHOW MECHANICALLY CONSIDERED	55
NOTES OF THE NEW YORK SHOW	57
A GASOLINE PROPELLED FIRE ENGINE	60
WOOD ALCOHOL AS AN ANTI-FREEZING MIXTURE	61
SELF-PROPELLED RAILWAY CAR	62
TRADE PUBLICATIONS	63
REACHLESS DOUBLE SPRING GEAR	65
INDUSTRIAL ITEMS	66

Vol. VII

PUBLISHED BY
THE GAS ENGINE PUBLISHING CO.
CINCINNATI · OHIO

No. 2



Edison Primary Batteries

Formerly
EDISON-LALANDE

There is no deterioration in the permanent parts of these batteries. It follows, therefore, that each time a cell is re-charged it will last as long a time and deliver as heavy a current as the original charge, when the cell was first put into service. Our catalogue No. 4. will tell you more about this. Let us send it.

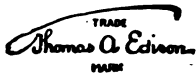

EDISON MFG. CO.

Factory, Orange, N. J.
New York, 31 Union Square.
Chicago, 304 Wabash Ave.

Gordon Battery

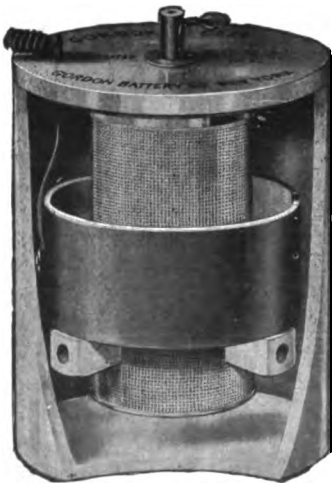

For IGNITION.

Easy to handle
and easy to re-charge.

Only one connection to unfasten and the whole cell can be taken apart.

Guaranteed long life and efficiency.

ASK FOR CATALOGUE.

GORDON BATTERY CO.,

439-445 East 144th St., NEW YORK, N. Y.

Index to Advertisers

Buyers' Guide, page 10

For Sale and Wants, page 13

Altemus, C. L. & Co. -	4
Bauroth Bros. - - - - -	14
Binsse Machine Co., The - - - - -	8
Boker, Hermann & Co. - - - - -	2
Bruce-Meriam-Abbott Co., - - - - -	4
Bullock-Beresford Mfg. Co., The - - - - -	4th Cover
Byrne, Kingston & Co. - - - - -	6
Carlisle & Finch Co. - - - - -	8
Columbus Machine Co. - - - - -	9
Dayton Electrical Mfg Co. - - - - -	4
Dean-Waterman Co., The - - - - -	9
Draftsman, The - - - - -	14
Dyke, A. L. - - - - -	15
Edison Mfg Co. - - - - -	2nd Cover
Eureka Separator Co. - - - - -	13
Fisher Special Mfg. Co. - - - - -	14
Fort Wayne Foundry & Machine Co. - - - - -	15
General Compressed Air Co. - - - - -	7
Gillespie, L. W. & Co. - - - - -	14
Goodson Electric Ignition Co., - - - - -	2. 7
Gordon Battery Co. - - - - -	2nd Cover.
Hardy, R. E. Co. - - - - -	14
Induction Coil Co., The - - - - -	14
International Power Vehicle Co. - - - - -	15
Jacobson Machine Mfg Co. - - - - -	8
Johns-Manville Co., H. W. - - - - -	5
McDonald & Erickson - - - - -	13
Motsinger Device Mfg. Co. - - - - -	14
National Coil Co. - - - - -	1
Neustadt Co., J. H. - - - - -	2
New Era Gas Engine Co. - - - - -	9
Obermayer Co., S. - - - - -	13
Oils Gasoline Engine Works - - - - -	9
Otto Gas Engine Works - - - - -	6
Patterson, Gottfried & Hunter, Ltd. - - - - -	1
Perfection Magneto Co. - - - - -	14
Powell, The Wm. Co. - - - - -	8
Remy Electric Co. - - - - -	14
Richardson Engineering Co. - - - - -	14
Roberts, E. W. - - - - -	4th Cover
Roth Bros & Co. - - - - -	7
Sargent, C. E. - - - - -	9
Strang Engine Co. - - - - -	15
Temple Pump Co. - - - - -	14
Turner Brass Works - - - - -	6
Union Drop Forge Co. - - - - -	1
Watkins, The Frank, M. Mfg. Co. - - - - -	5
Wile Power Gas Co. - - - - -	9

MAR 7 1905

THE NEW YORK
PUBLIC LIBRARY
ASTOR, LENOX AND
TILDEN FOUNDATIONS

BEAU
DE
ROCHAS
1862

CLARK
BRAYTON
HUGON
BARSANTI
MATEVILLI
MUYGERS
ATTORSON
OTTO
LEMOIR
MATTUCCI
BARNETT
PAPIN

THE GAS ENGINE

A MONTHLY MAGAZINE

Devoted to the interests of the
GAS-ENGINE INDUSTRY

STATIONARY-AUTOMOBILE-MARINE

MARCH, 1905.

CONTENTS

EDITORIAL	67
GETTING FUEL TO THE GAS ENGINE	68
POWER GAS FROM VEGETABLE PRODUCTS	70
THE GAS ENGINE IN ICE CREAM FACTORIES	71
NOTES ON THE THERMAL EFFICIENCY OF MODERN MOTIVE POWER ENGINES	73
GAS ENGINES FOR FACTORY POWER	75
THE NEW-DUR EXPLORER	78
ANSWERS TO INQUIRIES	81
GAS AND GASOLINE ENGINES FOR COAL MINES	83
AUTOMOBILE DEPARTMENT	84
SOME NOTES OF THE CHICAGO AUTOMOBILE SHOW	85
SOME TENDENCIES OF THE PARIS AUTOMOBILE SHOW	86
THE AUTOMOBILE POCKETBOOK	88
"CONTINENTAL" ENGINES	89
CARBURETERS	90
HOW TO EXAMINE A VERTICAL MOTOR	93
GAS DRIVEN LOCOMOTIVES AND SHIPS	94
ELECTRIC SPARKING FOR EXPLOSIVE MOTORS	96
TRADE PUBLICATIONS	97
INDUSTRIAL ITEMS	100
THE MARINE GAS ENGINE	100

Vol.
VII

PUBLISHED BY
THE GAS ENGINE PUBLISHING CO.
CINCINNATI OHIO

No.
3



Edison Primary Batteries

Formerly
EDISON-LALANDE

The renewal parts of these batteries are so proportioned that they all become exhausted at the same time. Ordinary materials may be used for some of the renewals, but the highest efficiency can only be secured by using our renewals. The reasons for this are explained in our catalogue No. 4. Send for it.

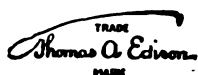

EDISON MFG. CO.

Factory, Orange, N. J.

New York, 31 Union Square
Chicago, 304 Wabash Ave.

One of the most important points

In favor of

GORDON CELL

is the
Simplicity of its Construction.

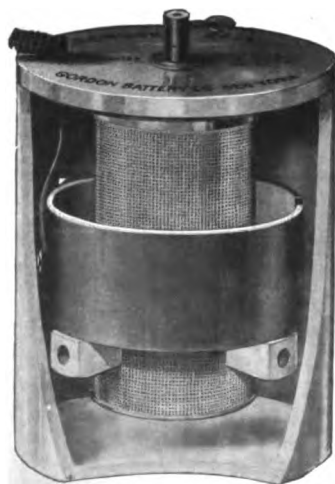

It is easy to set up and re-charge. Gordon Cells are easily connected together, there being only two connections on top. The construction prevents any confliction of the elements inside the cell.

Only the highest grade material obtainable is used throughout making them last longer than any other cell on the market.

Write for Catalogue and Prices

GORDON BATTERY COMPANY.

439-445 East 144th St.,

NEW YORK.

Index to Advertisers

Buyers' Guide, page 10

For Sale and Wants, page 16

Advance Mfg. Co.	- - - - -	5
Altemus, C. L. & Co.	- - - - -	4
Bauroth Bros.	- - - - -	14
Binsse Machine Co., The	- - - - -	8
Boker, Hermann & Co.	- - - - -	2
Bruce-Meriam-Abbott Co.,	- - - - -	4
Byrne, Kingston & Co.	- - - - -	15
Carlisle & Finch Co.	- - - - -	2
Columbus Machine Co.	- - - - -	15
Continental Engine Co.	- - - - -	2
Dayton Electrical Mfg. Co.	- - - - -	4
Dean-Mateman Co., The	- - - - -	9
Draftsman, The	- - - - -	14
Edison Mfg Co.	- - - - -	2nd Cover
Eureka Separator Co.	- - - - -	15
Fairbanks, Morse & Co.	- - - - -	1
Fischer Special Mfg. Co.	- - - - -	14
Foos Gas Engine Co.	- - - - -	8
Fort Wayne Foundry & Machine Co.	- - - - -	13
General Compressed Air Co.	- - - - -	1
Gillespie, L. W. & Co.	- - - - -	14
Goodson Electric Ignition Co.	- - - - -	1
Gordon Battery Co.	- - - - -	2nd Cover
Hardy, R. E. Co.	- - - - -	14
Henrieks Novelty Co.	- - - - -	9
Induction Coil Co., The	- - - - -	14
International Power Vehicle Co.	- - - - -	14
Jacobson Machine Mfg Co.	- - - - -	8
Johns-Manville Co., H. W.	- - - - -	7
McDonald & Erickson	- - - - -	13
Motsinger Device Mfg. Co.	- - - - -	13
Neustadt Co., J. H.	- - - - -	15
New Era Gas Engine Co.	- - - - -	9
Obermayer Co., S.	- - - - -	15
Olds Gasoline Engine Works	- - - - -	9
Otto Gas Engine Works	- - - - -	6
Patterson, Gottfried & Hunter, Ltd.	- - - - -	9
Perfection Magneto Co.	- - - - -	14
Powell, The Wm. Co.	- - - - -	8
Remy Electric Co.	- - - - -	14
Richardson Engineering Co.	- - - - -	14
Roberts, E. W.	- - - - -	18
Roth Bros & Co.	- - - - -	7
Sargent, C. E.	- - - - -	15
Strang Engine Co.	- - - - -	13
Temple Pump Co.	- - - - -	14
Turner Brass Works	- - - - -	15
Union Drop Forge Co.	- - - - -	1
Watkins, The Frank M. Mfg. Co.	- - - - -	6
Willson, H. B. & Co.	- - - - -	13

BEAU
DE
ROCHAS
1862

CLERK

BRAYTON

HUGON

BARSANTI

HAUTEVILLE

NUYGHERS

ATKINSON

OTTO

LEMOIR

MATTEUCCI

BARNETT

PAPIN

THE NEW YORK
PUBLIC LIBRARY
ASTOR, LENOX AND
TILDEN FOUNDATIONS.

• THE • GAS ENGINE

A MONTHLY MAGAZINE

Devoted to the interests of the
GAS-ENGINE INDUSTRY
STATIONARY · AUTOMOBILE · MARINE

APRIL, 1905.

CONTENTS

EDITORIAL	101
MOTOR LIFEBOATS	102
NATIONAL MOTOR BOAT AND SPORTSMAN'S SHOW	104
DEVELOPMENT OF THE GAS ENGINE	106
A GAS PRESSURE ANTI-FLUCTUATOR	107
OPERATING LARGE GAS ENGINES IN COLD WEATHER	109
ANOTHER AMERICAN SUCTION GAS PRODUCER	110
LEMARE'S SUCTION GAS PRODUCER	112
RECENT BOOKS ON GAS ENGINES AND AUTOMOBILES	113
THREATENED SHORTAGE OF GASOLINE	114
ANSWERS TO INQUIRIES	115
DEAN GAS ENGINES	117
GAS ENGINES FOR WATER WORKS SERVICE	118
AUTOMOBILE DEPARTMENT	120
THE TESTING OF GASOLINE ENGINES	121
WHY CYLINDERS MUST BE COOLED	125
AUTOMOBILES FOR LAUNDRIES	127
AUTOMOBILES FOR DRY GOODS MERCHANTS	128
MOTOR BOAT RATING	128
TRADE PUBLICATIONS	129
INDUSTRIAL ITEMS	130

Vol.
V 11

PUBLISHED BY
THE GAS ENGINE PUBLISHING CO.
CINCINNATI · OHIO

No.
4

B & C
Friction Clutch Pulley
PATENTED
FOR GASOLINE OR OIL ENGINES



Write for
 Prices and
 Particulars

BOLTS DIRECTLY ON ENGINE FLYWHEEL.
 Is Simple, Durable, Powerful, and Effective.

FOR SALE BY
PATTERSON, GOTTFRIED & HUNTER, Limited,
 146-150 Center St., NEW YORK CITY.

One of the most important points
 in favor of

GORDON CELL

is the
 Simplicity of its Construction.

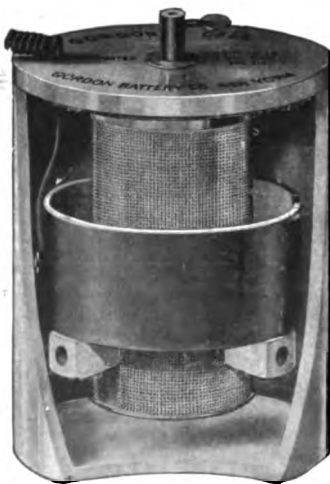

It is easy to set up and recharge. Gordon Cells are easily connected together, there being only two connections on top. The construction prevents any confliction of the elements inside the cell.

Only the highest grade material obtainable is used throughout making them last longer than any other cell on the market.

Write for Catalogue and Prices

GORDON BATTERY COMPANY.

439-445 East 144th St., NEW YORK.

Index to Advertisers

Buyers' Guide, page 10

For Sale and Wants, page 13

Altemus, C. L. & Co. -	7
Bauroth Bros. - - - - -	14
Beaver Machine Co., - - - - -	15
Boker, Hermann & Co. - - - - -	2
Bruce-Merjam-Abbott Co., - - - - -	7
Byrne, Kingston & Co. - - - - -	15
Carlisle & Finch Co. - - - - -	2
Columbus Machine Co. - - - - -	15
Continental Engine Co. - - - - -	2
Dayton Electrical Mfg Co. - - - - -	7
Dean-Waterman Co., The - - - - -	9
Draftsman, The - - - - -	14
Edison Mfg Co. - - - - -	4
Fairbanks, Morse & Co. - - - - -	1
Fischer Special Mfg. Co. - - - - -	14
Foos Gas Engine Co. - - - - -	8
Fort Wayne Foundry & Machine Co. - - - - -	16
General Compressed Air Co. - - - - -	5
Gillespie, L. W. & Co. - - - - -	14
Goodson Electric Ignition Co. - - - - -	5
Gordon Battery Co. - - - - -	2nd Cover
Hardy, R. E. Co. - - - - -	14
Henley, N. A., Pub. Co. - - - - -	6
Henricks Novelty Co. - - - - -	9
Herecules Electric & Manufacturing Co., - - - - -	14
International Power Vehicle Co. - - - - -	14
Jacobson Machine Mfg Co. - - - - -	8
Johns-Manville Co., H. W. - - - - -	1
McDonald & Erickson - - - - -	16
Motsinger Device Mfg. Co. - - - - -	16
Neustadt Co., J. H. - - - - -	15
New Era Gas Engine Co. - - - - -	9
Obermayer Co., S. - - - - -	15
Olds Gasoline Engine Works - - - - -	9
Otto Gas Engine Works - - - - -	5
Patterson, Gottfried & Hunter, Ltd. - - - - -	2d Cover
Perfection Magneto Co. - - - - -	14
Pitts, Geo. B. - - - - -	7
Powell, The Wm. Co. - - - - -	8
Remy Electric Co. - - - - -	14
Richardson Engineering Co. - - - - -	14
Roberts, E. W. - - - - -	18
Roth Bros & Co. - - - - -	7
Sargent, C. E. - - - - -	15
Strang Engine Co. - - - - -	16
Temple Pump Co. - - - - -	14
Turner Brass Works - - - - -	15
Union Drop Forge Co. - - - - -	1
Watkins, The Frank M. Mfg. Co. - - - - -	4
Wile Power Gas Co. - - - - -	9

May 2 05

THE NEW YORK
PUBLIC LIBRARY
ASTOR, LENOX AND
TILDEN FOUNDATION

BEAU
DE
ROCHAS
1862

CLARK

BRAYTON

HUGON

BARSANTI

MARTELLI

HUYGENS

ATURSON

OTTO

LENOIR

KATTECCCI

BARNETT

PAPIN

THE GAS ENGINE

A MONTHLY MAGAZINE

Devoted to the interests of the
GAS-ENGINE INDUSTRY

STATIONARY · AUTOMOBILE · MARINE

MAY, 1905.

CONTENTS

EDITORIAL	131
BRITISH COAL SUPPLIES	132
RECENT GERMAN GAS ENGINES	134
THE GAS ENGINE IN THE ARMY AND NAVY	135
POWER PRODUCTION FROM GASEOUS FUEL	136
A GAS ENGINE WRINKLE	141
ANSWERS TO INQUIRIES	142
BOOK REVIEWS	145
POST, PRESENT AND FUTURE OF MARINE PROPULSION	146
AUTOMOBILE DEPARTMENT	148
THE ULTIMATE LIMIT OF SPEED IN GAS ENGINES	149
RAILWAY MOTOR CAR	153
THE KINGSTON AUTOMATIC CARBURETER	154
THE WESTERN GAS ENGINE	156
PROGRESS OF THE GAS ENGINE	157
TRADE PUBLICATIONS	158
ITEMS	159
FOX'S REVERSIBLE ENGINE	160

Vol.
VII

PUBLISHED BY
THE GAS ENGINE PUBLISHING CO.
CINCINNATI · OHIO

No.
5

B & C Friction Clutch Pulley

PATENTED
FOR GASOLINE OR OIL ENGINES



BOLTS DIRECTLY ON ENGINE FLYWHEEL.
Is Simple, Durable, Powerful, and Effective.

FOR SALE BY
PATTERSON, GOTTFRIED & HUNTER, Limited,
146-150 Center St., NEW YORK CITY.

Write for
Prices and
Particulars

One of the most important points
in favor of

GORDON CELL

is the
Simplicity of its Construction.

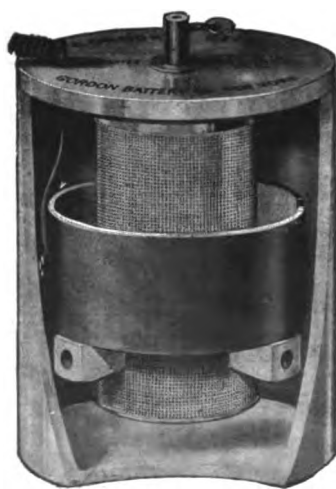

It is easy to set up and re-charge. Gordon Cells are easily connected together, there being only two connections on top. The construction prevents any conffliction of the elements inside the cell.

Only the highest grade material obtainable is used throughout making them last longer than any other cell on the market.

Write for Catalogue and Prices

GORDON BATTERY COMPANY.

439-445 East 144th St.,

NEW YORK.

Index to Advertisers

Buyers' Guide, page 12
For Sale and Wants, page 18

Advance Mfg. Co.,	- - - - -	5
Altemus, C. L. & Co.,	- - - - -	18
Beaver Machine Co.,	- - - - -	16
Boker, Hermann & Co.,	- - - - -	2
Bruce-Meriam-Abbott Co.,	- - - - -	7
Buchanan, John A.,	- - - - -	16
Byrne, Kingston & Co.,	- - - - -	19
Carlisle & Finch Co.,	- - - - -	9
Cincinnati Electric Tool Co.,	- - - - -	9
Cochran & Co.,	- - - - -	11
Columbus Machine Co.,	- - - - -	16
Continental Engine Co.,	- - - - -	2
Dayton Electrical Mfg Co.,	- - - - -	7
Dean-Waterman Co., The	- - - - -	11
Draftsman, The	- - - - -	8
Edison Mfg Co.,	- - - - -	4
Erle Foundry Co.,	- - - - -	2
Fairbanks, Morse & Co.,	- - - - -	8
Fischer Special Mfg. Co.,	- - - - -	16
Foos Gas Engine Co.,	- - - - -	10
Fort Wayne Foundry & Machine Co.,	- - - - -	18
Fox's Reversible Engine Works,	- - - - -	16
General Compressed Air Co.,	- - - - -	9
Gillespie, L. W. & Co.,	- - - - -	16
Goodson Electric Ignition Co.,	- - - - -	17
Gordon Battery Co.,	- - - - -	2d Cover
Hardy, R. E. Co.,	- - - - -	18
Henley, N. A., Pub. Co.,	- - - - -	6
Henricks Novelty Co.,	- - - - -	11
Hercules Electric & Manufacturing Co.,	- - - - -	16
International Harvester Co. of America	- - - - -	1
International Power Vehicle Co.,	- - - - -	16
Jacobson Machine Mfg Co.,	- - - - -	10
Johns-Manville Co., H. W.,	- - - - -	4
Kitselman Bros.,	- - - - -	8
Lambert Gas & Gasoline Engine Co.,	- - - - -	17
McDonald & Erickson	- - - - -	15
"M. E."	- - - - -	17
Motsinger Device Mfg. Co.,	- - - - -	15
Neustadt Co., J. H.,	- - - - -	17
New Era Gas Engine Co.,	- - - - -	11
Obermayer Co., S.,	- - - - -	16
Olds Gasoline Engine Works	- - - - -	11
Otto Gas Engine Works	- - - - -	7
Patterson, Gottfried & Hunter, Ltd.,	- - - - -	2d Cover
Perfection Magneto Co.,	- - - - -	15
Powell, The Wm. Co.,	- - - - -	10
Remy Electric Co.,	- - - - -	16
Richardson Engineering Co.,	- - - - -	17
Roberts, E. W.,	- - - - -	22
Roth Bros & Co.,	- - - - -	10
Sargent, C. E.,	- - - - -	17
Strang Engine Co.,	- - - - -	15
Temple Pump Co.,	- - - - -	8
Turner Brass Works	- - - - -	19
Union Drop Forge Co.,	- - - - -	1
Watkins, The Frank M. Mfg. Co.,	- - - - -	8
Western Iron Works,	- - - - -	16

THE NEW YORK
PUBLIC LIBRARY.
ASTOR, LENOX AND
TILDEN FOUNDATIONS.

BEAU
DE
ROCHAS
1862

CLARK
BATES
HUGER
BARNETT
MARTZELLE
MUYCHERS
ATKINSON
OTTO
LEMOIR
KATRUCCI
BARNETT
PAPIN

THE GAS ENGINE

A MONTHLY MAGAZINE
Devoted to the interests of the
GAS-ENGINE INDUSTRY
STATIONARY · AUTOMOBILE · MARINE
JUNE, 1905.

C O N T E N T S

EDITORIAL	161
THE REASONING GAS ENGINE OPERATOR	162
EXPERIENCE	164
A COKE GAS PRODUCER	165
GAS ENGINE INQUIRIES	167
THE GAS ENGINE IN THE BLACKSMITH SHOP	168
GASOLINE ENGINES IN CHINA	169
FOOS GAS ENGINES	170
DECISION INVOLVING HORSEPOWER	171
THE GAS ENGINE AND THE CIRCUS	173
ANSWERS TO INQUIRIES	174
POWER GAS	175
BOOK REVIEWS	177
PRODUCER GAS UNITS	178
WEIGHT AND SPEED OF THE GAS ENGINE	181
PICKING COTTON BY GASOLINE ENGINE	182
AUTOMOBILE DEPARTMENT	183
CARBURETERS	184
GASOLINE ENGINE FOR COMMERCIAL VEHICLES	189
MOTORS FOR AGRICULTURAL PURPOSES	191
TRADE PUBLICATIONS	192
ITEMS	193

Vol.
VII

PUBLISHED BY
THE GAS ENGINE PUBLISHING CO.
CINCINNATI · OHIO

No.
6

The Smith Automatic Suction Gas Producer

Is the only gas producer that will operate successfully on

**One charge of fuel
per twenty-four
hours**

We have several plants installed that have been in daily operation for from one to three years and which regularly receive absolutely no attention save for **ONE CLEANING AND CHARGING PER 24 HOURS.**

These producers have many other valuable features. We will tell you more about them in this space from time to time. Our catalogue will reach you more quickly, however.

May we send you one?

Smith Gas Power Co.

Lexington, Ohio, U. S. A.

Index to Advertisers

**Buyers' Guide, page 12
For Sale and Wants, page 18**

Altemus, C. L. & Co.	8
Beaver Machine Co.,	16
Boker, Hermann & Co.	2
Bruce-Meriam-Abbott Co.,	8
Burt Manufacturing Co.	3, 11
Byrne, Kingston & Co.	5
Carlisle & Finch Co.	9
Cincinnati Electric Tool Co.,	9
Cochran & Co.,	5
Columbus Machine Co.	16
Continental Engine Co.	2
Dayton Electrical Mfg Co.	7
Dean-Waterman Co., The	11
Edison Mfg Co.	16
Erie Foundry Co.,	2
Fairbanks, Morse & Co.	9
Fischer Special Mfg. Co.	16
Foos Gas Engine Co.	10
Fort Wayne Foundry & Machine Co.	15
Fox's Reversible Engine Works,	16
General Compressed Air Co.	7
Gillespie, L. W. & Co.	16
Goodson Electric Ignition Co.	5
Gordon Battery Co.	19
Hardy, R. E. Co.	8
Henricks Novelty Co.	11
Hercules Electric & Manufacturing Co.,	17
International Harvester Co. of America	4
Jacobson Machine Mfg Co.	10
Johns-Manville Co., H. W.	4
Kendrick & Davis	16
Lambert Gas & Gasoline Engine Co., K.	10
McCord & Co.	3
McDonald & Erickson	18
Motsinger Device Mfg. Co.	15
National Carbon Co.	8
Neustadt Co., J. H.	17
New Era Gas Engine Co.	11
Obermayer Co., S.	17
Olds Gasoline Engine Works	11
Otto Gas Engine Works	1
Patterson, Gottfried & Hunter, Ltd.	19
Perfection Magneto Co.	16
Powell, The Wm. Co.	10
Remy Electric Co.	16
Richardson Engineering Co.	15
Roberts, E. W.	4th Cover
Roth Bros & Co.	5
Sargent, C. E.	16
Smith Gas Power Co.	2nd Cover
Strang Engine Co.	18
Temple Pump Co.	17
Turner Brass Works	3
Union Drop Forge Co.	1
Watkins, The Frank M. Mfg. Co.	7
Western Gas Engine Co.	16
Wile Power Gas Co.,	8

BEAU
DE
ROCHAS
1862

CLARK

ATKINSON

OTTO

BLAYTON

HUGER

BABBARTY

MATEVILLE

HOYCHERS

LEONARD NEW YORK
PUBLIC LIBRARY

MATTEUCCI
ARTON
TILDE

BARNETT

PAPIN

THE GAS ENGINE

A MONTHLY MAGAZINE

Devoted to the interests of the
GAS-ENGINE INDUSTRY
STATIONARY · AUTOMOBILE · MARINE

JULY, 1905.
CONTENTS

EDITORIAL	195
THE REASONING GAS ENGINE OPERATOR	196
SOME GAS POWER TESTS	198
SHIPPING PORTABLE GASOLINE ENGINES	199
FACTORS IN GAS ENGINE DEVELOPMENT	200
THE SMITH GAS PRODUCER	201
A GASOLINE DRIVEN ROCK DRILL	203
MOTOR BOATS IN NORWAY	205
ANSWERS TO INQUIRIES	207
SPECIAL GENERATORS FOR GAS ENGINES	210
"ECHOES FROM THE OIL COUNTRY"	211
RELATIVE ADVANCEMENT OF SPARK SYSTEMS	214
A HIGH COMPRESSION GAS ENGINE	216
AUTOMOBILE DEPARTMENT	217
ALCOHOL AS A FUEL FOR MOTORS	218
LENGTH OF MOTORS	220
COMPRESSION	221
GASOLINE PROPELLED RAILWAY CARS	222
MOTOR CAR IN ENGLISH LAUNDRY SERVICE	224
BALL-BEARING CRANKSHAFT	226
STOPPING TESTS--MOTOR CAR VS HORSES	226
THE K. & D. IGNITER	227
BOOK REVIEWS	228

Vol.
VII

PUBLISHED BY
THE GAS ENGINE PUBLISHING CO.
CINCINNATI · OHIO

No.
7

B & C Friction Clutch Pulley

PATENTED
FOR GASOLINE OR OIL ENGINES



BOLTS DIRECTLY ON ENGINE FLYWHEEL.
Is Simple, Durable, Powerful, and Effective.

FOR SALE BY
PATTERSON, GOTTFRIED & HUNTER, Limited,
146-150 Center St., NEW YORK CITY.

Write for
Prices and
Particulars

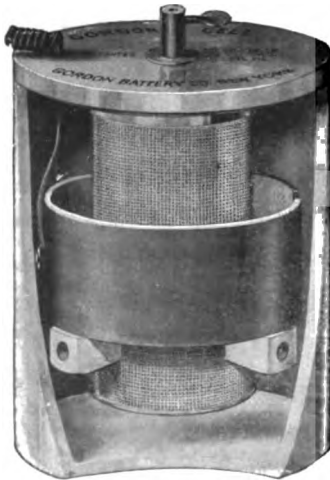

Gordon Cells

Simple in construction.

Easy to set up and recharge.

Only two connections on top—one a wire ready to be connected to next cell.

No possibility of short circuit inside the Cell.

Highest grade material obtainable used throughout.

No loss of energy while cell is idle.

Last longer and cost less to maintain than any other ignition device.

Will not freeze.

Our Catalogue tells all about them.

GORDON BATTERY CO.

439-445 East 144th Street - NEW YORK

Index to Advertisers

Buyers' Guide, page 12
For Sale and Wants, page 16

Advance Mfg. Co.	- - - - -	5
Altemus, C. L. & Co.	- - - - -	7
Audel & Co.	- - - - -	7
Beaver Machine Co., F.	- - - - -	14
Boker, Hermann & Co.	- - - - -	2
Bruce-Merlam-Abbott Co.,	- - - - -	7
Burt Manufacturing Co.	- - - - -	11
Byrne, Kingston & Co.	- - - - -	7
Carlisle & Finch Co.	- - - - -	9
Cincinnati Electric Tool Co.,	- - - - -	9
Cochran & Co.,	- - - - -	11
Columbus Machine Co.	- - - - -	14
Continental Engine Co.	- - - - -	2
Dayton Electrical Mfg Co.	- - - - -	4
Dean-Waterman Co., The	- - - - -	11
Draftsman, The	- - - - -	7
Edison Mfg Co.	- - - - -	3
Erie Foundry Co.,	- - - - -	2
Fairbanks, Morse & Co.	- - - - -	9
Fischer Special Mfg. Co.	- - - - -	14
Foos Gas Engine Co.	- - - - -	10
Fort Wayne Foundry & Machine Co.	- - - - -	8
Fox's Reversible Engine Works,	- - - - -	14
Gas Engine Supply Co.	- - - - -	15
General Compressed Air Co.	- - - - -	4
Godson Electric Ignition Co.	- - - - -	6
Gordon Battery Co.	- - - - -	2nd Cover
Hardy, R. E. Co.	- - - - -	8
Henricks Novelty Co.	- - - - -	14
Jacobson Machine Mfg Co.	- - - - -	10
Johns-Manville Co., H. W.	- - - - -	6
Kendrick & Davis	- - - - -	14
Lambert Gas & Gasoline Engine Co., K.	- - - - -	10
McCord & Co.	- - - - -	3
McDonald & Erickson	- - - - -	7
National Carbon Co.	- - - - -	8
Nungesser Electric Battery Co.	- - - - -	15
Olds Gasoline Engine Works	- - - - -	11
Otto Gas Engine Works	- - - - -	1
Patterson, Gottfried & Hunter, Ltd.,	- - - - -	2nd Cover
Perfection Magneto Co.	- - - - -	14
Powell, The Wm. Co.	- - - - -	10
Remy Electric Co.	- - - - -	14
Richardson Engineering Co.	- - - - -	7
Richmond Electric Co.	- - - - -	15
Roberts, E. W.	- - - - -	4th Cover
Roth Bros & Co.	- - - - -	6
Sargent, C. E.	- - - - -	14
Schug Electric Mfg. Co.	- - - - -	3
Smith Gas Power Co.	- - - - -	8
Southern Machine Mfg. Co.	- - - - -	7
Strang Engine Co.	- - - - -	3
Strelinger, Co., C. A.	- - - - -	15
Temple Pump Co.	- - - - -	14
Turner Brass Works	- - - - -	15
Union Drop Forge Co.	- - - - -	1
Watkins, The Frank M. Mfg. Co.	- - - - -	4
Western Gas Engine Co.	- - - - -	14

BEAU
DE
ROCHAS
1862

HUYGHERS
MATEUCCI
BARNETT
PAPIN
LENOIR
OTTO
ATKINSON
CLERK
DYWIDOFF
FUGON
BARSAFTI
MATEUCCI

• THE • GAS ENGINE

A MONTHLY MAGAZINE
Devoted to the interests of the
GAS-ENGINE INDUSTRY
STATIONARY · AUTOMOBILE · MARINE

AUGUST, 1905.
CONTENTS

EDITORIAL	231
THE REASONING GAS ENGINE OPERATOR	232
THE GROWTH OF LARGE GAS ENGINES ON THE CONTINENT	234
SOUNDING FOR BRIDGE AND DAM FOUNDATIONS	238
GAS PRODUCER POWER PLANTS	240
SOME GAS ENGINE ACCIDENTS	244
SOME GAS ENGINES AT THE LIEGE EXHIBITION	246
THE MECHANICAL EFFICIENCY OF THE GAS ENGINE	247
ANSWERS TO INQUIRIES	249
SOME EUROPEAN GAS ENGINE OUTPUT	250
GAS AND OIL ENGINES IN SWEDEN	250
AUTOMOBILE DEPARTMENT	251
SOME EUROPEAN TENDENCIES	252
AUTOMOBILE TRANSPORTATION IN MINING DISTRICTS	258
ALCOHOL AS A FUEL FOR MOTORS	260
PRODUCER GAS TESTS AT ST. LOUIS	261
BOOK REVIEWS	262
MOTOR BOAT FALLACIES	263
THE STEAM TURBINE AND THE GAS ENGINE	263
THE GORDON-BENNETT RACE	264
MOTOR PROPELLED CANAL BOATS	254
WOOD GAS FOR POWER	265
ITEMS	266

Vol.
VII

PUBLISHED BY
THE GAS ENGINE PUBLISHING CO.
CINCINNATI · OHIO

No.
8

B & C
Friction Clutch Pulley
PATENTED
FOR GASOLINE OR OIL ENGINES



Write for
 Prices and
 Particulars

BOLTS DIRECTLY ON ENGINE FLYWHEEL.
 Is Simple, Durable, Powerful, and Effective.

FOR SALE BY

PATTERSON, GOTTFRIED & HUNTER, Limited,
 146-150 Center St., NEW YORK CITY.



Gordon

Cells

Simple in construction.

Easy to set up and recharge.

Only two connections on top—one a wire ready to be connected to next cell.

No possibility of short circuit inside the Cell.

Highest grade material obtainable used throughout.

No loss of energy while cell is idle.

Last longer and cost less to maintain than any other ignition device.

Will not freeze.

Our Catalogue tells all about them.

GORDON BATTERY CO.

439-445 East 144th Street - NEW YORK

Index to Advertisers

Buyers' Guide, page 12

For Sale and Wants, page 15

Altemus, C. L. & Co. -	7
Audel & Co. - - - - -	7
Beaver Machine Co., F. - - - - -	14
Boker, Hermann & Co. - - - - -	2
Bruce-Merriam-Abbott Co., - - - - -	7
Burt Manufacturing Co. - - - - -	11
Byrne, Kingston & Co. - - - - -	7
Carlisle & Finch Co. - - - - -	9
Cincinnati Electric Tool Co., - - - - -	9
Columbus Machine Co. - - - - -	14
Continental Engine Co. - - - - -	2
Dayton Electrical Mfg Co. - - - - -	4
Dean-Waterman Co., The - - - - -	11
Draftsman, The - - - - -	7
Edison Mfg Co. - - - - -	3
Erle Foundry Co., - - - - -	2
Fairbanks, Morse & Co. - - - - -	9
Fischer Special Mfg. Co. - - - - -	14
Foos Gas Engine Co. - - - - -	10
Fort Wayne Foundry & Machine Co. - - - - -	5
Fox's Reversible Engine Works, - - - - -	14
Gas Engine Supply Co. - - - - -	15
General Compressed Air Co. - - - - -	4
Goodson Electric Ignition Co. - - - - -	4th Cover
Gordon Battery Co. - - - - -	2nd Cover
Hardy, R. E. Co. - - - - -	5
Henricks Novelty Co. - - - - -	14
Jacobson Machine Mfg Co. - - - - -	10
Johns-Manville Co., H. W. - - - - -	8
Kendrick & Davis - - - - -	14
Lambert Gas & Gasoline Engine Co., K. - - - - -	10
McCord & Co. - - - - -	3
McDonald & Erickson - - - - -	7
National Carbon Co. - - - - -	1
Nungesser Electric Battery Co. - - - - -	5
Olds Gasoline Engine Works - - - - -	11
Otto Gas Engine Works - - - - -	1
Patterson, Gottfried & Hunter, Ltd., 2nd Cover	
Perfection Magneto Co. - - - - -	14
Powell, The Wm. Co. - - - - -	10
Remy Electric Co. - - - - -	14
Richardson Engineering Co. - - - - -	7
Richmond Electric Co. - - - - -	5
Roberts, E. W. - - - - -	3d Cover
Sargent, C. E. - - - - -	14
Schug Electric Mfg. Co. - - - - -	3
Smith Gas Power Co. - - - - -	8
Southern Machine Mfg. Co. - - - - -	7
Strang Engine Co. - - - - -	3
Strelinger, Co., C. A. - - - - -	5
Temple Pump Co. - - - - -	14
Turner Brass Works - - - - -	5
Union Drop Forge Co. - - - - -	1
Watkins, The Frank M. Mfg. Co. - - - - -	4
Western Gas Engine Co. - - - - -	14
Wile Gas Power Co. - - - - -	11

THE NEW YORK
PUBLIC LIBRARY

BEAU
DE
ROCHAS
1862

THE GAS ENGINE

A MONTHLY MAGAZINE

Devoted to the interests of the
GAS-ENGINE INDUSTRY

STATIONARY · AUTOMOBILE · MARINE

SEPTEMBER, 1905

CONTENTS

EDITORIAL	267
THE REASONING GAS ENGINE OPERATOR	268
THE GASOLINE ENGINE AND THE CIRCUS	269
THE DESIGNER SHOWN IN HIS ENGINE	270
GAS NEWS	271
GAS FOR POWER	273
UNDERWRITERS' REGULATIONS ON GAS PRODUCERS	274
SOME SCOTCH ENGINE AND PRODUCER TESTS	275
A SPECIAL ELECTRIC GAS ENGINE	276
ANSWERS TO INQUIRIES	279
GOVERNMENT INVESTIGATION OF GAS ENGINES	281
THE LAUNCH GREGORY	284
THE GAS TURBINE	286
AUTOMOBILE DEPARTMENT	287
SOME EUROPEAN TENDENCIES	288
A TWO-CYCLE AIR-COOLED ENGINE	295
INSTALLING GASOLINE ENGINES	295
GAS ENGINE SOUNDS	297
GAS AS A MOTIVE POWER AND ITS RELATIVE COST	298
BOOK REVIEWS	298
THE "WONDER" GASOLINE MOTOR	299
INDUSTRIAL ITEMS	300
TRADE PUBLICATIONS	302

Vol.
VII

PUBLISHED BY
THE GAS ENGINE PUBLISHING CO.
CINCINNATI · OHIO

No.
9

B & C Friction Clutch Pulley

PATENTED
FOR GASOLINE OR OIL ENGINES

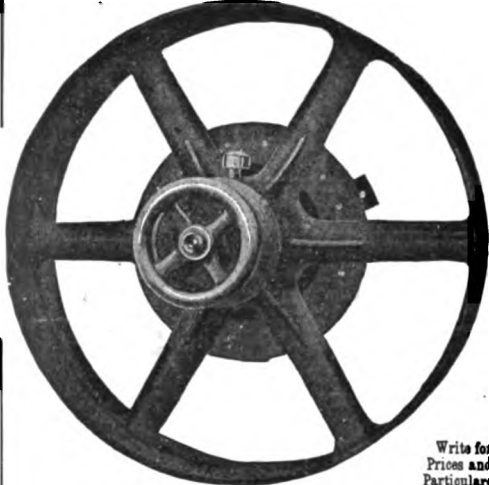

Write for
Prices and
Particulars

BOLTS DIRECTLY ON ENGINE FLYWHEEL.
Is Simple, Durable, Powerful, and Effective.

FOR SALE BY
PATTERSON, GOTTFRIED & HUNTER, Limited,
146-150 Center St., NEW YORK CITY.

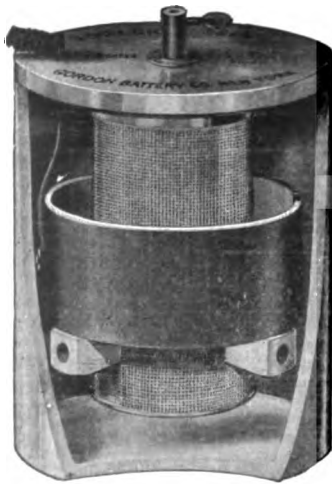

Gordon Cells

Simple in construction.

Easy to set up and recharge.

Only two connections on top—one a wire ready to be connected to next cell.

No possibility of short circuit inside the Cell.

Highest grade material obtainable used throughout.

No loss of energy while cell is idle.

Last longer and cost less to maintain than any other ignition device.

Will not freeze.

Our Catalogue tells all about them.

GORDON BATTERY CO.

439-445 East 144th Street - NEW YORK

Index to Advertisers

Buyers' Guide, page 12

For Sale and Wants, page 15

Advance Mfg. Co.	- - -	4th Cover
Altemus, C. L. & Co.	- - -	7
Audel & Co.	- - -	7
Beaver Machine Co., F.	- - -	14
Boker, Hermann & Co.	- - -	2
Bruce-Meriam-Abbott Co.,	- - -	11
Burt Manufacturing Co.	- - -	11
Byrne, Kingston & Co.	- - -	7
Carlisle & Finch Co.	- - -	3
Cincinnati Electric Tool Co.,	- - -	9
Columbus Machine Co.	- - -	14
Continental Engine Co.	- - -	2
Dayton Electrical Mfg Co.	- - -	1
Dean-Waterman Co., The	- - -	11
Draftsman, The	- - -	7
Edison Mfg Co.	- - -	7
Erie Foundry Co.,	- - -	2
Fairbanks, Morse & Co.	- - -	9
Fischer Special Mfg. Co.	- - -	14
Foos Gas Engine Co.	- - -	10
Fort Wayne Foundry & Machine Co.	- - -	5
Fox's Reversible Engine Works,	- - -	14
General Compressed Air Co.	- - -	4
Goodson Electric Ignition Co.	- - -	9
Gordon Battery Co.	- - -	2nd Cover
Hardy, R. E. Co.	- - -	5
Henricks Novelty Co.	- - -	14
I. X. L. Steam Packing Mfg. Co.	- - -	3
Jacobson Machine Mfg Co.	- - -	10
Johns-Manville Co., H. W.	- - -	8
Kendrick & Davis	- - -	14
Lambert Gas & Gasoline Engine Co., K.	- - -	10
McCord & Co.	- - -	3
McDonald & Erickson	- - -	7
National Carbon Co.	- - -	4
Nungesser Electric Battery Co.	- - -	5
Olds Gasoline Engine Works	- - -	11
Otto Gas Engine Works	- - -	1
Patterson, Gottfried & Hunter, Ltd.,	2nd Cover	
Perfection Magneto Co.	- - -	14
Powell, The Wm. Co.	- - -	10
Remy Electric Co.	- - -	14
Richardson Engineering Co.	- - -	7
Richmond Electric Co.	- - -	5
Roberts, E. W.	- - -	3d Cover
Sargent, C. E.	- - -	14
Schug Electric Mfg. Co.	- - -	6
Smith Gas Power Co.	- - -	8
Southern Machine Mfg. Co.	- - -	7
Strang Engine Co.	- - -	6
Strelinger, Co., C. A.	- - -	5
Temple Pump Co.	- - -	14
Union Drop Forge Co.	- - -	1
Watkins, The Frank M. Mfg. Co.	- - -	4
Western Gas Engine Co.	- - -	14

106 2 06

NEW YORK
PUBLIC LIBRARY
ASTOR, LENOX AND
TILDEN FOUNDATIONS

BEAU
DE
ROCHAS
1862

BRAYTON
CLARK
ATKINSON
OTTO
LEMOIRE
MATEUCCI
BARNETT
PAPIE
HUGGER
BASSARTI
MATEFVILLE
HUYGHERS

• THE • GAS ENGINE

A MONTHLY MAGAZINE
Devoted to the interests of the
GAS-ENGINE INDUSTRY
STATIONARY · AUTOMOBILE · MARINE

OCTOBER, 1905
CONTENTS

EDITORIAL	303
AN INDIANA GAS PRODUCER PLANT	304
A FLY WHEEL FORMULA	309
THE REASONING GAS ENGINE OPERATOR	310
PATIENCE WITH THE GASOLINE ENGINE	311
CLIFTON MARINE ENGINES	313
OIL IN THE GAS ENGINE CYLINDER	314
PRONY BRAKE CAPACITY	315
BOOK REVIEWS	315
A COMBUSTION SIGHT-HOLE	316
PRODUCER GAS VS. GASOLINE IN MINE HOISTS	318
A COOLING WATER ARRANGEMENT FOR GAS ENGINES	319
IMPLEMENT DEALERS AND GAS ENGINES	320
SOME RECENT ENGLISH INVENTIONS	323
AUTOMOBILE DEPARTMENT	325
SOME EUROPEAN TENDENCIES	326
KNABENSHUE'S AIRSHIP	332
THE McCLELLAND OIL PURIFIER	333
ANSWERS TO INQUIRIES	334
TRADE PUBLICATIONS	336
INDUSTRIAL ITEMS	337
DE DION ENGINE DIMENSIONS	338
NON FREEZING SOLUTIONS	338

Vol.
VII

PUBLISHED BY
THE GAS ENGINE PUBLISHING CO.
CINCINNATI · OHIO

No.
10

B & C Friction Clutch Pulley

PATENTED
FOR GASOLINE OR OIL ENGINES

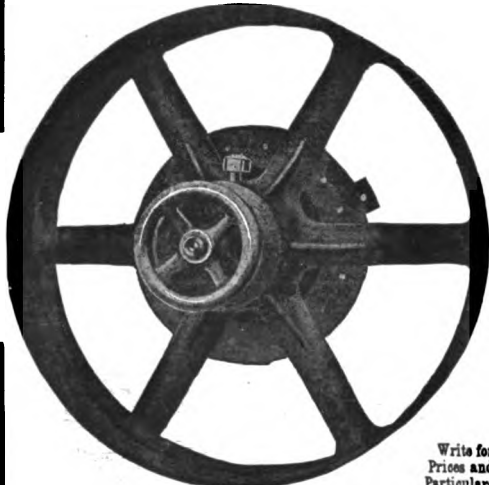

Write for
Prices and
Particulars

BOLTS DIRECTLY ON ENGINE FLYWHEEL.
Is Simple, Durable, Powerful, and Effective.

FOR SALE BY
PATTERSON, GOTTFRIED & HUNTER, Limited,
146-150 Center St., NEW YORK CITY.

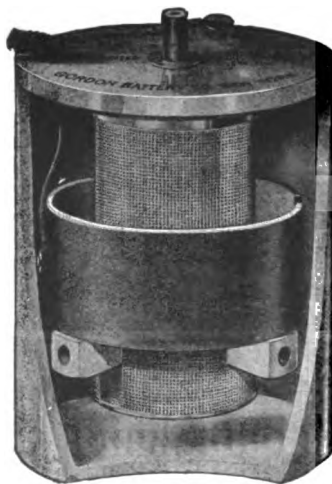

Gordon Cells

Simple in construction.

Easy to set up and recharge.

Only two connections on top—one a wire ready to be connected to next cell.

No possibility of short circuit inside the Cell.

Highest grade material obtainable used throughout.

No loss of energy while cell is idle.

Last longer and cost less to maintain than any other ignition device.

Will not freeze.

Our Catalogue tells all about them.

GORDON BATTERY CO.

439-445 East 144th Street - NEW YORK

Index to Advertisers

Buyers' Guide, page 12
For Sale and Wants, page 18

Altemus, C. L. & Co. - - - - -	5
Audel & Co. - - - - -	14
Beaver Machine Co., F. - - - - -	15
Boker, Hermann & Co. - - - - -	2
Bruce-Meriam-Abbott Co., - - - - -	11
Bullock Ignitor Co. - - - - -	3
Burt Manufacturing Co. - - - - -	11
Byrne, Kingston & Co. - - - - -	7
Cincinnati Electric Tool Co., - - - - -	9
Clifton Motor Works, - - - - -	16
Columbus Machine Co. - - - - -	15
Continental Engine Co. - - - - -	2
Dayton Electrical Mfg Co. - - - - -	1
Dean-Waterman Co., The - - - - -	11
Draftsman, The - - - - -	14
Edison Mfg Co. - - - - -	16
Erie Foundry Co., - - - - -	2
Fairbanks, Morse & Co. - - - - -	9
Fischer Special Mfg. Co. - - - - -	15
Foos Gas Engine Co. - - - - -	10
Fort Wayne Foundry & Machine Co. - - - - -	5
Fox's Reversible Engine Works, - - - - -	15
Gas Engine Whistle Co. - - - - -	7
General Compressed Air Co. - - - - -	4
Goodson Electric Ignition Co. - - - - -	9
Gordon Battery Co. - - - - -	2nd Cover
Hardy, R. E. Co. - - - - -	5
Henricks Novelty Co. - - - - -	15
I. X. L. Steam Packing Mfg. Co. - - - - -	3
Jacobson Machine Mfg Co. - - - - -	10
Johns-Manville Co., H. W. - - - - -	17
Kendrick & Davis - - - - -	15
Lambert Gas & Gasoline Engine Co., K. - - - - -	10
McCord & Co. - - - - -	3
McDonald & Erickson - - - - -	14
Motsinger Device Mfg. Co. - - - - -	14
National Carbon Co. - - - - -	4
Nungesser Electric Battery Co. - - - - -	5
Olds Gasoline Engine Works - - - - -	11
Otto Gas Engine Works - - - - -	1
Patterson, Gottfried & Hunter, Ltd., 2nd Cover	
Perfection Magneto Co. - - - - -	15
Powell, The Wm. Co. - - - - -	10
Remy Electric Co. - - - - -	15
Richardson Engineering Co. - - - - -	14
Richmond Electric Co. - - - - -	5
Roberts, E. W. - - - - -	20
Ruprecht Igniter & Electric Co. - - - - -	14
Sargent, C. E. - - - - -	15
Schug Electric Mfg. Co. - - - - -	14
Smith Gas Power Co. - - - - -	7
Southern Machine Mfg. Co. - - - - -	14
Strang Engine Co. - - - - -	14
Strelinger, Co., C. A. - - - - -	5
Temple Pump Co. - - - - -	15
Union Drop Forge Co. - - - - -	1
Watkins, The Frank M. Mfg. Co. - - - - -	4
Western Gas Engine Co. - - - - -	15
Wile Gas Power Co. - - - - -	18

THE NEW YORK
PUBLIC LIBRARY
ASTOR, LENOX AND
TILDEN FOUNDATIONS.

BEAU
DE
ROCHAS
1862

CLARK
BRAYTON
FUGER
BARBANTI
MARTINELLI
HUYGHERS
ATKINSON
OTTO
LENGIER
MATTUCCI
BARRETT
PAPIN

• THE • GAS ENGINE

A MONTHLY MAGAZINE

Devoted to the interests of the
GAS-ENGINE INDUSTRY
STATIONARY · AUTOMOBILE · MARINE

NOVEMBER, 1905

CONTENTS

EDITORIAL	339
THE REASONING GAS ENGINE OPERATOR	340
THE 5,000 H.P. GAS ENGINES OF THE CALIFORNIA GAS AND ELECTRIC CORPORATION	342
POWER FOR LIGHT MANUFACTURING FROM SUC- TION PRODUCER GAS	345
THE GASOLINE ENGINE ON THE FARM	347
ANSWERS TO INQUIRIES	351
SOME CANADIAN IMPORT FIGURES	352
APPLICATION OF GAS POWER TO ELECTRIC RAILWAY SERVICE	353
IS GAS POWER MORE ECONOMICAL THAN WATER POWER?	356
THE EFFECT OF HYDROGEN ON GAS ENGINE COMPRESSION	358
AUTOMOBILE DEPARTMENT	361
POSSIBILITIES OF THE AUXILIARY EXHAUST	362
SOME COMMON TROUBLES AND REMEDIES	363
ENGINE BRAKING	365
THE GASOLINE ENGINE PISTON	368
A GASOLINE ENGINE REPAIR JOB	370

Vol.
VII

PUBLISHED BY
THE GAS ENGINE PUBLISHING CO.
CINCINNATI · OHIO

No.
11

B & C Friction Clutch Pulley

PATENTED
FOR GASOLINE OR OIL ENGINES

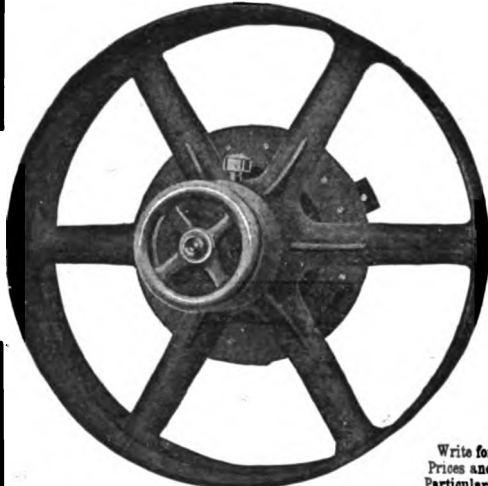

Write for
Prices and
Particulars

BOLTS DIRECTLY ON ENGINE FLYWHEEL.
Is Simple, Durable, Powerful, and Effective.

FOR SALE BY

PATTERSON, GOTTFRIED & HUNTER, Limited,
146-150 Center St., NEW YORK CITY.

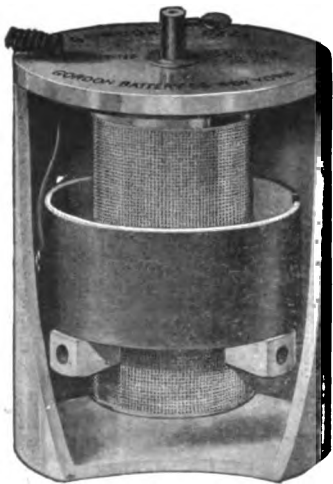

Gordon Cells

Simple in construction.
Easy to set up and recharge.

Only two connections on top—one a wire ready to be connected to next cell.

No possibility of short circuit inside the Cell.

Highest grade material obtainable used throughout.

No loss of energy while cell is idle.

Last longer and cost less to maintain than any other ignition device.

Will not freeze.

Our Catalogue tells all about them.

GORDON BATTERY CO.

439-445 East 144th Street - NEW YORK

Index to Advertisers

Buyers' Guide, page 12

For Sale and Wants, page 17

Advance Mfg. Co.	- - -	3rd Cover
Altemus, C. L. & Co.	- - -	5
Audel & Co.	- - -	14
Beaver Machine Co., F.	- - -	15
Boker, Hermann & Co.	- - -	2
Bruce-Meriam-Abbott Co.,	- - -	11
Bullock Ignitor Co.	- - -	3
Burt Manufacturing Co.	- - -	11
Byrne, Kingston & Co.	- - -	7
Cincinnati Electric Tool Co.,	- - -	8
Clifton Motor Works,	- - -	16
Columbus Machine Co.	- - -	15
Continental Engine Co.	- - -	2
Cornwell Co., The R. M.	- - -	14
Dayton Electrical Mfg Co.	- - -	1
Dean Gas Engine & Foundry Co.	- - -	11
Draftsman, The	- - -	17
Edison Mfg Co.	- - -	16
Erie Foundry Co.,	- - -	2
Excelsior Spark Plug Co.	- - -	4
Fairbanks, Morse & Co.	- - -	8
Field-Brundage Co., The	- - -	10
Fischer Special Mfg. Co.	- - -	15
Foos Gas Engine Co.	- - -	10
Fort Wayne Foundry & Machine Co.	- - -	5
Fox's Reversible Engine Works,	- - -	15
Gas Engine Whistle Co.	- - -	7
General Compressed Air Co.	- - -	4
Goodson Electric Ignition Co.	- - -	8
Gordon Battery Co.	- - -	2nd Cover
Hardy, R. E. Co.	- - -	5
Henricks Novelty Co.	- - -	15
I. X. L. Steam Packing Mfg. Co.	- - -	3
Kendrick & Davis	- - -	14
Lambert Gas & Gasoline Engine Co., K.	- - -	10
McCord & Co.	- - -	3
McClure-Buchner Co.	- - -	15
Motor Boat	- - -	16
Motsinger Device Mfg. Co.	- - -	14
National Carbon Co.	- - -	4
Nungesser Electric Battery Co.	- - -	5
Olds Gasoline Engine Works	- - -	11
Otto Gas Engine Works	- - -	1
Patterson, Gottfried & Hunter, Ltd.,	- - -	2nd Cover
Perfection Magneto Co.	- - -	15
Powell, The Wm. Co.	- - -	10
Remy Electric Co.	- - -	15
Richardson Engineering Co.	- - -	16
Richmond Electric Co.	- - -	5
Roberts, E. W.	- - -	20
Ruprecht Igniter & Electric Co.	- - -	14
Sargent, C. E.	- - -	14
Schug Electric Mfg. Co.	- - -	14
Smith Gas Power Co.	- - -	7
Southern Machine Mfg. Co.	- - -	16
Strang Engine Co.	- - -	14
Strelinger, Co., C. A.	- - -	5
Temple Pump Co.	- - -	15
Union Drop Forge Co.	- - -	1
Western Gas Engine Co.	- - -	15

57 6 05

Inlay

THE NEW YORK
PUBLIC LIBRARY.
ASTOR, LENOX AND
TILDEN FOUNDATIONS.

BEAU
DE
ROCHAS
1862

HUGER
BARSANTI
MATEVILLE
MUYGERS
CLARK
MATEY
ATTINSON
OTTO
LENOIR
MATTECCI
BARNETT
PAPIN

THE GAS ENGINE

A MONTHLY MAGAZINE

Devoted to the interests of the
GAS-ENGINE INDUSTRY
STATIONARY · AUTOMOBILE · MARINE

DECEMBER, 1905

CONTENTS

EDITORIAL	375
PRICE VS. QUALITY	376
TAKE CARE OF YOUR ENGINE	377
GAS VS. GASOLINE ENGINES	380
THE ETNA GREEN, IND. LIGHTING STATION	384
CALCIUM CHLORIDE SOLUTION	385
MOTOR BOATS IN AUSTRALIA	386
THE ENDER FRICTION CLUTCH PULLEY	387
A GAS DRIVEN COUNTRY HOUSE ELECTRIC LIGHT INSTALLATION	389
DESIGN OF LARGE GAS ENGINES	390
GAS ENGINE DRIVEN RAILWAY STATION	393
"WHAT CAUSED THE GAS ENGINE TO STOP?"	394
AUTOMOBILE DEPARTMENT	397
RESULTS OF ECONOMY TESTS	398
UNION PACIFIC MOTOR, No. 2	398
THE NUMBER OF CYLINDERS	399
PREVENTING SMOKE FROM MOTORS	404
A HOT GASOLINE ENGINE	406
A 400 H.P. RACING BOAT	407
INDUSTRIAL ITEMS	409
TRADE PUBLICATIONS	410

Vol.
VII

PUBLISHED BY
THE GAS ENGINE PUBLISHING CO.
CINCINNATI · OHIO

No.
12

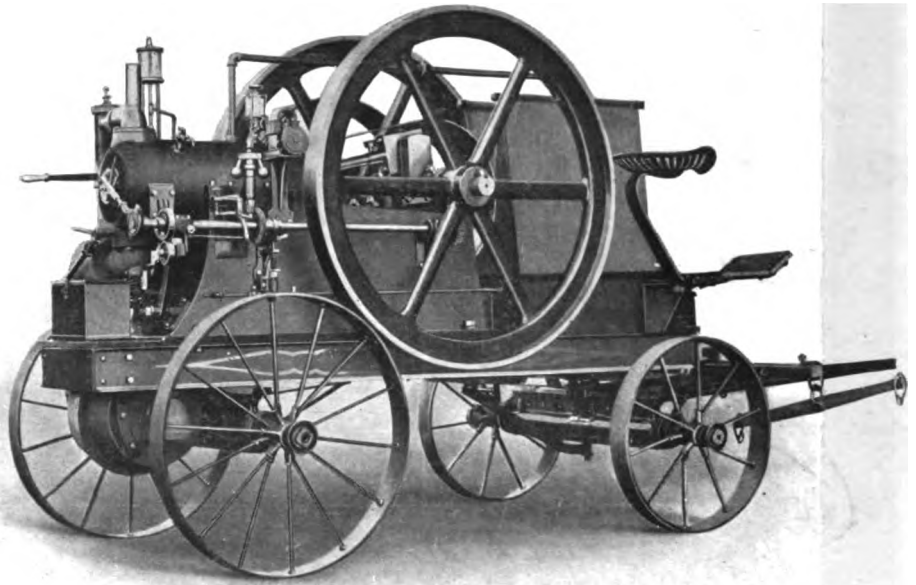

Get a sample engine, then get an agency for our full line of engines from 1 1/4 H.P. pumping engine to the largest size. Send for our new catalogue and after reading the points of merit, you will handle no other but

THE ANGOLA

The engine will do the rest. In all sizes, both portable and traction built.

ANGOLA ENGINE & FOUNDRY COMPANY, ANGOLA, INDIANA

Index to Advertisers

Buyers' Guide, page 12

For Sale and Wants, page 16

Altemus, C. L. & Co. - - - - -	4	General Compressed Air Co. - - - - -	9
Angola Engine & Foundry Co. - - 2nd Cover		Goodson Electric Ignition Co. - - - - -	7
Audel & Co. - - - - -	16	Gordon Battery Co. - - - - -	3
Beaver Machine Co., F. - - - - -	15	Hardy, R. E. Co. - - - - -	5
Boker, Hermann & Co. - - - - -	2	Henricks Novelty Co. - - - - -	15
Bruce-Meriam-Abbott Co., - - - - -	11	Hercules Electric & Mfg. Co. - - - - -	15
Bullock Ignitor Co. - - - - -	7	Kendrick & Davis - - - - -	14
Burt Manufacturing Co. - - - - -	11	Lambert Gas & Gasoline Engine Co., K. - - - - -	10
Byrne, Kingston & Co. - - - - -	7	McCord & Co. - - - - -	3
Clifton Motor Works. - - - - -	8	McClure-Buchner Co. - - - - -	14
Columbus Machine Co. - - - - -	14	Merriam G. & C. Co. - - - - -	4
Continental Engine Co. - - - - -	2	Motor Boat - - - - -	4
Cornwell Co., The R. M. - - - - -	15	Motsinger Device Mfg. Co. - - - - -	4
Cross Engine Co., M. O. - - - - -	14	National Carbon Co. - - - - -	1
Dayton Electrical Mfg Co. - - - - -	5	Nungesser Electric Battery Co. - - - - -	7
Dean Gas Engine & Foundry Co. - - - - -	11	Olds Gasoline Engine Works - - - - -	11
Draftsman, The - - - - -	16	Otto Gas Engine Works - - - - -	1
Edison Mfg Co. - - - - -	5	Patterson, Gottfried & Hunter, Ltd., - - - - -	3
Erie Foundry Co., - - - - -	2	Perfection Magneto Co. - - - - -	14
Excelsior Spark Plug Co. - - - - -	9	Powell, The Wm. Co. - - - - -	10
Fairbanks, Morse & Co. - - - - -	9	Remy Electric Co. - - - - -	14
Field-Brundage Co., The - - - - -	10	Rhodes, James H. & Co. - - - - -	14
Fischer Special Mfg. Co. - - - - -	14	Richmond Electric Co. - - - - -	5
Foos Gas Engine Co. - - - - -	10	Roberts, E. W. - - - - -	3d Cover
Fort Wayne Foundry & Machine Co. - - - - -	4	Ruprecht Igniter & Electric Co. - - - - -	14
Fox's Reversible Engine Works, - - - - -	15	Sargent, C. E. - - - - -	14
Gas Engine Whistle Co. - - - - -	7	Schug Electric Mfg. Co. - - - - -	5
Geer, Harry R. Co. - - - - -	15	Smith Gas Power Co. - - - - -	8
		Southern Machine Mfg. Co. - - - - -	14
		Springfield Gas Engine Co. - - - - -	9
		Strang Engine Co. - - - - -	15
		Strelinger, Co., C. A. - - - - -	5
		Temple Pump Co. - - - - -	15
		Union Drop Forge Co. - - - - -	1
		Western Gas Engine Co. - - - - -	3
		Wile Power Gas Co., - - - - -	8

THE GAS ENGINE.

1



Drop Forgings of all kinds.

For AUTOMOBILES, STATIONARY and MARINE GAS and GAS-OLINE ENGINES. Send for crank and valve sheet.

UNION DROP FORGE COMPANY,

70 to 72 East Ohio Street,

CHICAGO, ILL.

More work at 1/4 the expense

FRAND & COMPANY, Metal Workers, Camden N. J., say:-

"We are doing more work with our gas engine than we ever did with the steam plant and are only using one ton of coal per week, whereas, we used four to five tons per week with the steam plant. Our present plant is so near automatic in its operation that the attention required is inconsiderable. We firmly believe our OTTO power plant is superior to anything now on the market for efficiency and general satisfaction."

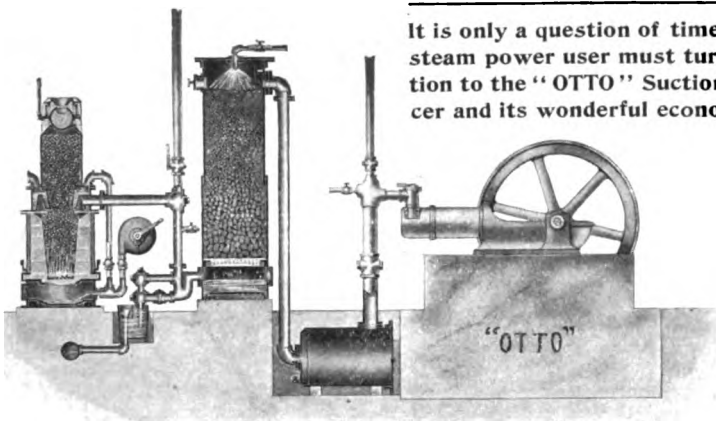

It is only a question of time when every steam power user must turn his attention to the "OTTO" Suction Gas Producer and its wonderful economy.

Details in Catalogue.

THE OTTO GAS ENGINE WORKS, Philadelphia, Pa.



BEST FOR IGNITION
COLUMBIA
DRY CELLS



SEND FOR CATALOGUE

NATIONAL CARBON COMPANY, Cleveland, Ohio

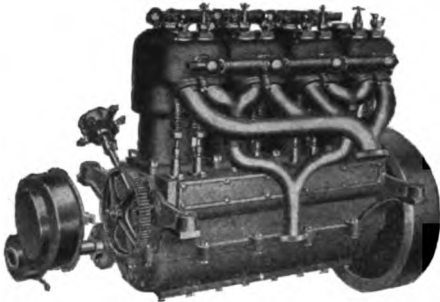

Type "B" One of 8 Types

Western GASOLINE MOTORS & Power Equipments

Both Portable and Stationary. } Air and
1½ to 60 H.P. 2 and 4 Cycle. } Water Cooled

Special Shop Facilities

All Types Transmission Outfits.
Every Accessory for Motor Boats.

We Build and Estimate for Business.

Solutions and Designs Furnished
to suit your requirements. Con-
sulting and Inspection.

Since the consolidation of our
several factories we are the only international builders in the world.

LET US PURCHASE YOUR CHASSIS MATERIAL

THE CONTINENTAL ENGINE CO. OFFICE & WORKS, COR. KINGSBURY & HURON STS CHICAGO

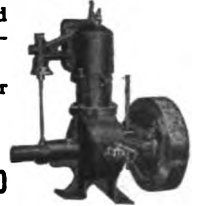

Reversing 2 H.P. 2-Cycle

NICKEL ALLOY Ignition TUBES

and RODS for Tubes.

LAST FROM 7-12 MONTHS.

OVER 175 GAS ENGINE BUILDERS USE THEM.

Exhaust Valve
Forgings

Never Break or Crystallize.
SEND FOR PARTICULARS.



Meteor Wire

::: FOR :::

SPARKING POINTS

(Non-Corrosive)

Fully Equal to Platinum - According to Testimonials.

HERMANN BOKER & CO., 101-103 Duane St., New York.

WESTERN OFFICE, No. 63 N. DESPLAINES ST., CHICAGO, ILL.

HIGH GRADE

Engine and Machinery Castings

LARGE AND SMALL

A FEW OF OUR CUSTOMERS: Otto Gas Engine Works, Lambert
Gas and Gasoline Engine Co.,
Olin Gas Engine Co., Ball Engine Co., Jacobson Machine Manufacturing Co.,
Burke Electric Co., Chicago Pneumatic Tool Co., De La Vergne Machine Co.

Try us. Write us. Let us come to see you.
No casting too difficult. No order too large or too small.

Erie Foundry Company

1218 W. 12th Street
ERIE, PENNA.

MENTION "THE GAS ENGINE" WHEN WRITING TO ADVERTISERS.

McKim

Copper

Asbestos

Gaskets

McCord & Co.

1429
Old
Colony
Building

Chicago, Illinois

McCanna

Force

Feed

Lubricators

Write for Catalogue

THE WESTERN

Burns Cheap Distillates, Kerosene,
Naphtha, Benzine or Gasoline

OPERATES WITH CRUDE OIL
AND WITH ANY KIND OF GAS

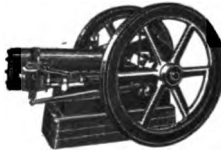

Send for new catalogue.

USES LESS THAN ANY
OTHER ENGINE BUILT

Sizes, 4 to 100 H. P.

• Stationary or Portable

WESTERN GAS ENGINE CO. Los Angeles, Cal.

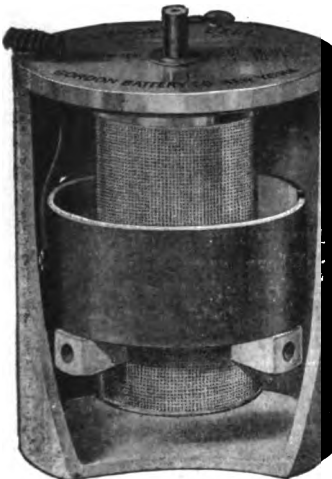

**Gordon
Cells**

Simple in construction.

Easy to set up and recharge.

Only two connections on top—one a wire ready to be connected to next cell.

No possibility of short circuit inside the Cell.

Highest grade material obtainable used throughout.

No loss of energy while cell is idle.

Last longer and cost less to maintain than any other ignition device.

Will not freeze.

Our Catalogue tells all about them.

GORDON BATTERY CO.

439-445 East 144th Street - NEW YORK

**B & C
Friction Clutch Pulley**
PATENTED
FOR GASOLINE OR OIL ENGINES



Write for
Prices and
Particulars

BOLTS DIRECTLY ON ENGINE FLYWHEEL.
Is Simple, Durable, Powerful, and Effective.

FOR SALE BY

PATTERSON, GOTTFRIED & HUNTER, Limited,
146-150 Center St., NEW YORK CITY.

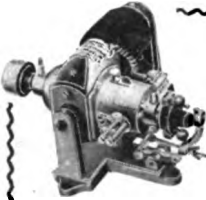

To Gas Engine Operators.
Dynamo Ignition.
**Motsinger
Auto-Sparker**

No battery to start or run. The original speed-controlled friction-drive Dynamo. Driven parallel with engine shaft. No belts No beveled pulley or beveled fly wheel necessary. For make and break and jump-spark system. Water and dust proof. FULLY GUARANTEED.

We have an attractive proposition for the Dealer in Gas Engine lines. Correspondence solicited. Write for 32-page catalogue, FREE. MOTSINGER DEVICE MANUFACTURING CO. 109 Main Street, Pendleton, Ind., U. S. A

The Motor Boat

Published Twice a Month
10th and 25th.

1133 BROADWAY, NEW YORK

Ten cents a Copy.
Two Dollars a Year.

From 64 to 100 Pages of Illustrated Boat and Engine Matter. Sample on request. Your newsdealer can get it for you.

For valuable information on

Jump Spark Ignition

Address

C. L. ALTEMUS & CO.
The Bourse, Philadelphia, Pa.

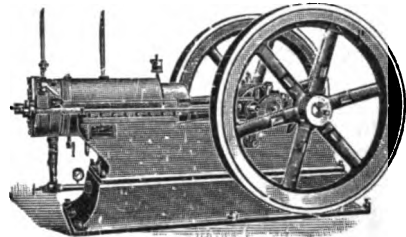

**6
to
150
H. P.**

“Wayne” Gas and Gasoline Engines.

SEND FOR CATALOGUE.

Fort Wayne Foundry and Machine Co.,
Fort Wayne, Ind.

**GRAND PRIZE
Highest Award
WORLD'S FAIR
ST. LOUIS**

**WEBSTER'S
INTERNATIONAL
DICTIONARY**

RECENTLY ENLARGED
WITH
25,000 New Words and Phrases
New Gazetteer of the World
New Biographical Dictionary
Edited by W. T. Harris, Ph.D., LL.D.,
United States Commissioner of Education.
2380 Quarto Pages. 5000 Illustrations.

Also Webster's Collegiate Dictionary
1116 Pages. 1400 Illustrations.
Regular Edition 7 x 10 x 2 3/8 inches. 3 bindings.
De Luxe Edition 5 3/4 x 8 5/8 x 1 1/2 in. Printed from
same plates, on bible paper. 2 beautiful bindings.

FREE, "Dictionary Wrinkles." Illustrated pamphlets.

G. & C. MERRIAM CO.
Publishers, Springfield, Mass.
GET THE BEST

The No. 16 Acme Dry Battery

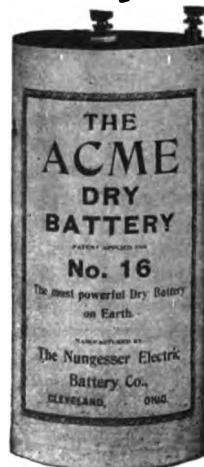

Represents
the
Power,
Life
and
Uniformity
necessary
for
perfect
Ignition
Service.

Manufactured by

THE NUNGESSER ELECTRIC BATTERY CO.
CLEVELAND, OHIO.

General Sales Office:

128 West Jackson Blvd, CHICAGO

MENTION "THE GAS ENGINE" WHEN WRITING TO ADVERTISERS.

Casalloy

for

Igniter Points

This alloy is very satisfactory. We have customers who prefer it to platinum or iridium, and a good many customers who like it just as well, and like the price much better.

The Chas. A. Strelinger Company
Box G-411, DETROIT, MICH.

Schug Spark Coils are Reliable Why?

Write us and we will tell you.



Schug Electric Mfg. Co.
DETROIT, MICH.



Generators for Gas Engines

We have made a special study of the requirements of this service. Our special accurately balanced fly wheel will not correct a racing governor, but will absorb explosion pulsation in belted service. Our direct connected type has flexible coupling which permits the fly wheel to absorb the pulsation just as in belted installations. Bulletin 7 gives further information.

The Richmond Electric Company,
P. O. Box 164, RICHMOND, VA.

We are Ignition Specialists

If you have any trouble with your ignition, write to us and we will tell you just what to do. Our **Apple Automatic Sparker** gives a strong, steady current that never fails. No trouble to put on any car or engine; our friction driving gear makes installation easy. See us at N. Y. and Chicago auto show. For full information write THE DAYTON ELECTRICAL MFG CO., 139 Beaver Building, Dayton, Ohio.



TRADE MARK

Thomas A Edison

Renew Edison Batteries with Edison Renewals.

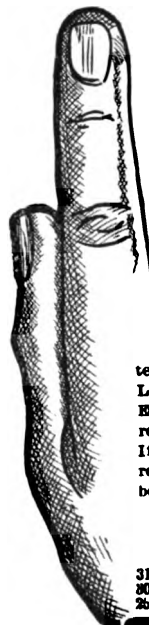

All the elements of the Edison Battery work together perfectly. The high constant electromotive force, the absence of polarization, or loss of energy during idleness, the low internal resistance—in fact, all the superior and distinctive features of the Edison Battery are due to the accurate and intelligent preparation of its elements. Only the highest grade of material is used and Mr. Edison's own formulas are carefully followed. See that your Edison Batteries are recharged with Edison Renewals. Look for the trade mark illustrated above. Edison Batteries recharged with substituted renewals do not give the same satisfaction. If you are having any trouble look into the renewal question. It's important. Send for booklet No. 4.

EDISON MFG. CO.
ORANGE, N. J.

31 Union Square, - - - - - NEW YORK
204 Wabash Ave. - - - - - CHICAGO
26 Clerkenwell Road. - - - - - LONDON



How would you like to have your engine develop 10 percent More Power?

We can make them do it for others, and can do as well for you. Our improved jump spark system of ignition is adaptable to any gas engine. State make. Spark coils and motor accessories.

THE R. E. HARDY CO.,
225 W. Broadway, NEW YORK CITY.

MENTION "THE GAS ENGINE" WHEN WRITING TO ADVERTISERS.

Special Clubbing List.

Offer No.		Regular Price.	Clubbing Price.
10	{ The Gas Engine, one year - - - -	\$1.00	\$3.50 FOR \$2.50
	{ The Gas Engine Handbook - - - -	1.50	
	{ Gas Engine Troubles and Remedies -	1.00	
11	{ The Gas Engine, one year - - - -	1.00	\$2.50 FOR \$2.00
	{ The Gas Engine Handbook - - - -	1.50	
12	{ The Gas Engine, one year - - - -	1.00	\$2.00 FOR \$1.50
	{ Gas Engine Troubles and Remedies -	1.00	
15	{ The Gas Engine, one year - - - -	1.00	\$3.50 FOR \$2.50 Blue Prints, \$4.00
	{ How to Build a 3 H. P. Launch Engine (Blue Prints, \$4.00 extra) - - -	2.50	
16	{ The Gas Engine, one year - - - -	1.00	\$6.00 FOR \$4.00 Blue Prints, \$4.00 Extra.
	{ The Gas Engine Handbook - - - -	1.50	
	{ Gas Engine Troubles and Remedies -	1.00	
	{ How to Build a 3 H. P. Launch Engine (Blue Prints, \$4.00 extra) - - -	2.50	
17	{ The Gas Engine, one year - - - -	1.00	\$2.00 FOR \$1.50
	{ Suction Gas - - - - -	1.00	

The AUTOMOBILE POCKETBOOK may be substituted for the GAS ENGINE HANDBOOK.

The Gas Engine Publishing Co.,

54 Blymyer Building, CINCINNATI, OHIO.

Kingston Carburetor

Over 30,000 in Use.

Patented May 17, 1908.

Other Patents
Pending

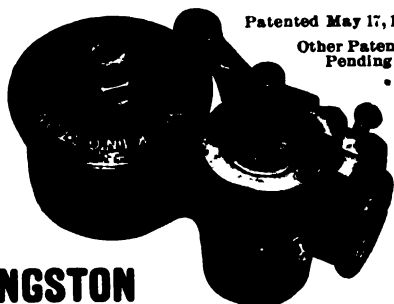

KINGSTON

Carburetors, Mufflers, Spark-Coils, Spark-Plugs, Steering Wheels, Pumps, Oiling Devices, Etc.

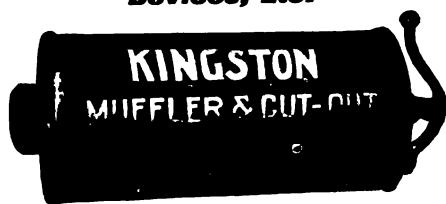

Byrne, Kingston & Co., Kokomo, Ind. U. S. A.

A Whistle for your Gas Engine is now possible.

THE

Watres Spent Gas Whistle

can be attached to any gas or gasoline engine and is always ready for a loud, strong blast.

It costs \$35.00, complete and is sent anywhere under absolute agreement to refund purchase price at end of one month, if not satisfactory in every way.

GAS ENGINE WHISTLE CO.

1133-B Broadway, New York

Send for Booklet No. 1, Boat Whistle; No. 2, Automobile Power Brake or No. 3, Stationary Engine Whistle.

Chicago Representative:

Wm. R. Johnston, 1336 Michigan Avenue

Do you use Jump Spark?

If so, you must get the

EXCELSIOR "Easy Clean" Spark Plug

It will do away with all of your spark plug troubles. Is more soot-proof than any plug heretofore produced. If fouled can be instantly cleaned, without removing the plug, stopping the engine or disconnecting the wiring. It also forms a very convenient compression relief cock.

A Revolution
in
Spark Plugs.

Write for particulars.

Excelsior Spark Plug Company,
Dept. G. CLEVELAND, OHIO

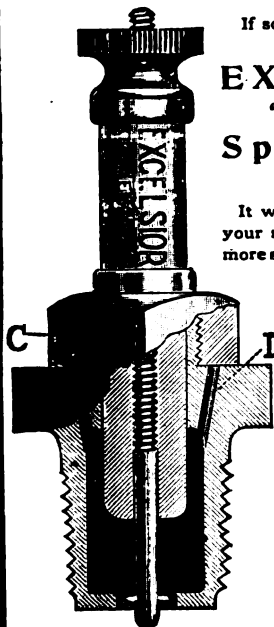

THE

Bullock Ignitor

was the Original Primary Sparker.

Can be readily applied to any engine. Beware of worthless imitations, ask for the new duplex model. If your dealer cannot supply you, order direct.

Bulletin "G"
Mailed on Request.

The Bullock Ignitor Co.

Cleveland, Ohio

**Clifton
Marine Gasoline Engines**

1½ to
80 H.P.

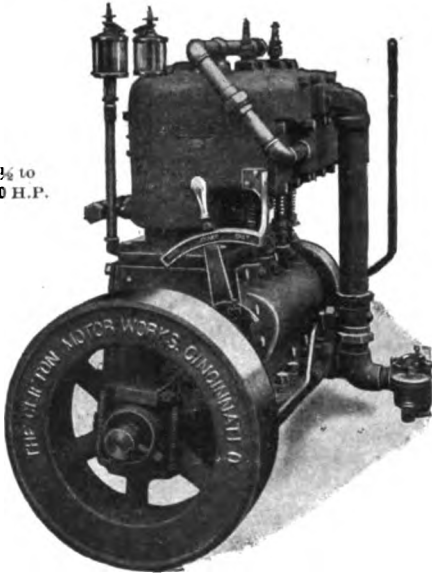

The Clifton Motor Works,

227 East Clifton Avenue, CINCINNATI, OHIO

PRODUCER

GAS

Reduces Cost of Power

Suction and pressure gas
producers for power and
all kinds of furnace work.

CATALOGS
ON APPLICATION

Wile Power Gas Co.

==== Rochester, N. Y. ====

A Car Load a Year

is the amount of coal
required for this plant.

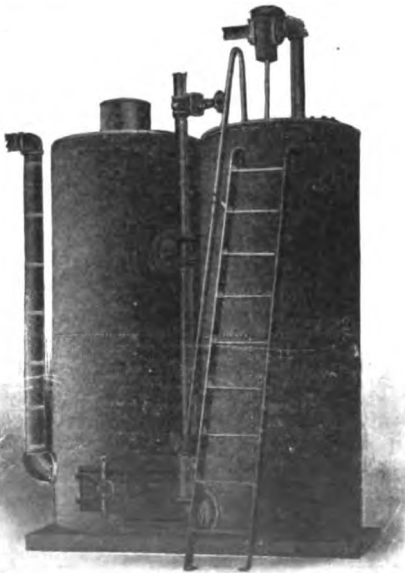

ETNA GREEN ELECTRIC ... LIGHT PLANT ...

T. M. JONES, Prop.

ETNA GREEN, IND.

"The gas engine plant is working every night and is working fine. It is the greatest money saver I ever saw.

"I got a car load of pea size hard coal the second of January, 1905 and burned it in a hard coal stove for two and a half months besides using it in the producer, and I have enough to run me a month yet. It all cost \$149.50 delivered here. Last year I ran my engine on gasoline, and it cost me \$660.00, and I did not run as long as I do now. You can bank on the Smith Producer. It is all right.

Yours truly,

Etna Green, Ind., Nov. 1, 1905.

T. M. JONES."

This plant was installed
in February, 1904.

SMITH GAS POWER CO., Lexington, Ohio, U. S. A.

MENTION "THE GAS ENGINE" WHEN WRITING TO ADVERTISERS.

Producer Gas

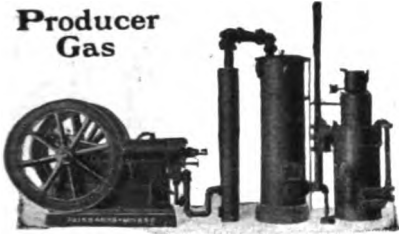

For Power

The saving in FUEL alone, over the usual Steam Engine, will almost buy the plant in a year or so.

The actual figures are startling.
It is almost as cheap as water power!

Send for Producer Gas Booklet No. 470 A

FAIRBANKS, MORSE & CO.,

Chicago
Cleveland
Cincinnati

St. Paul
Portland, Ore.
Minneapolis

St. Louis
Kansas City
Detroit

San Francisco
Los Angeles
Salt Lake City

Indianapolis
Louisville
New York

Omaha
Denver
London, Eng.

... The ...

Endter Friction Clutch Pulley



Especially adapted to Gas, Gasoline and Oil Engines. This is the original "short shaft" clutch and has been in use since 1898. It can be applied to any make of engine. Write for catalog 14.

Manufactured and sold by

The Springfield Gas Engine Co.

Springfield, O., U.S.A.

Gas Engines and Air Compressors of ever class for shops, marine, mines, building and bridge construction.

We manufacture Gasoline, Electrical and Belt Driven Air Compressors.

Our Gasoline Direct Connected Air Compressors are the only machines of their kind in the world.

Our Gasoline Engines or Compressors are mounted on wagons to make them portable.

Write for Catalog.

GENERAL COMPRESSED AIR CO., 3933 Olive St., ST. LOUIS, MO.



Do you use a Gas or Gasoline Engine?

If so our booklet "Points to be Considered in Selecting an Igniter" will interest you, because it contains many valuable points in regard to electric ignition and the economical operation of gas and gasoline engines. Send four cents in stamps for copy.

The Goodson Igniter will start your engine without batteries or spark coil, no belts, friction wheels, pulleys or switches are used.

Carbon, oil, grease, soot, etc., have no effect on the spark. Our catalogue sent free on request.

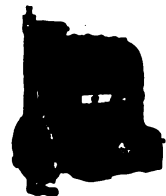

Goodson Electric Ignition Co. Providence, R. I.

THE GAS

FOOS

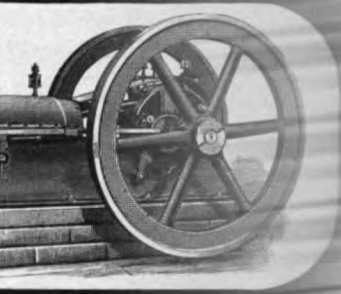

ENGINES
received the
GOLD MEDAL
at the Portland Exposition
40 page Catalogue, No. 26 is full of
facts and will tell you why
the **FOOS** always wins.

Gas Engine Co.,
Springfield, Ohio

Field Engine

Great in design; simple in
construction; quickly understood
and quiet in operation and exper-
ience demonstrates very econ-
omy in the consumption of fuel.
water-packing joints to
Automatic starting device.
Igniter that always ignites.
Simple and satisfactory in every
respect. Write for catalog.

Field-Brundage Co., Jack
M

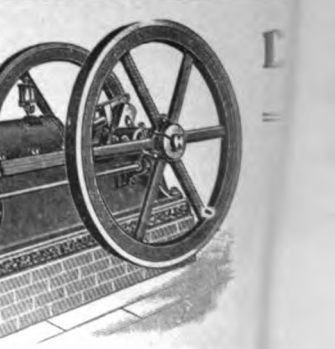

MENTION "THE GAS"



ENGINES

COULD YOU LI
aid your
ster Cycle

78

Buyer's Guide.

The Gas - Engine Industry and Allied Appliances.

ADVANCE MFG. CO.,

"Hamilton" Gas and
Gasoline Engines.
Hamilton, Ohio.

ALTEMUS, C. L. & CO.,

Circuit Breaker and Timer.
The Bourse, Philadelphia, Pa.

ANGOLA ENGINE & FOUNDRY CO.,

Gas and Gasoline Engines.
Angola, Ind.

AMERICAN COIL CO.,

Jump Spark Coils, Plugs,
Igniting Dynamos.
Foxboro, Mass.

AUDEL & CO.,

Book Publishers.
63 Fifth Avenue, New York, N. Y.

BEAVER, F., MACHINE CO.,

Gas and Gasoline Engines.
220 East Second Street, Cincinnati, O.

BOKER, HERMANN, & CO.,

Ignition Tubes and Materials.
101-103 Duane Street, New York, N. Y.
63 N. Desplaines Street. - Chicago, Ill.

BRUCE - MERIAM - ABBOTT CO.,

Gas and Gasoline Engines.
8-12 Columbus Street, Cleveland, O.

BULLOCK IGNITOR CO., THE,

Magnetic Igniters.
Cleveland, Ohio.

BURT MFG. CO., THE,

Oil Filters.
260 Main Street, Akron, O.

BYRNE, KINGSTON & CO.,

Kingston Carbureter, Mufflers, etc.
Kokomo, Ind.

CLIFTON MOTOR WORKS,

Marine Engines.
227 E. Clifton Ave., Cincinnati, O.

COLUMBUS MACHINE CO.,

Gas and Gasoline Engines.
Columbus, Ohio.

CONTINENTAL ENGINE CO., THE,

Gasoline Motors and
Power Equipment.
Kingsbury and Huron Sts., Chicago, Ill.

CORNWELL CO., THE R. M.,

Wonder Gasoline Engines,
448 S. Salina St., Syracuse, N. Y.

DAYTON ELECTRICAL MFG. CO.,

Ignition Apparatus.
139 Beaver Building, Dayton, Ohio.

**DEAN GAS ENGINE & FOUNDRY CO.,
THE,**

Gas and Gasoline Engines.
Newport, Ky.

DIXON, JOS., CRUCIBLE CO.,

Special Graphite No. 635.
For Gas Engines.
Jersey City, N. J.

EDISON MFG. CO.,

Edison Primary Batteries and Spark Coils.
Factory, Orange, N. J.
31 Union Square, New York.
304 Wabash Avenue, Chicago.

ERIE FOUNDRY CO.,

Gas Engine Castings.
Erie, Pa.

EXCELSIOR SPARK PLUG CO.,

"Easy Clean" Spark Plugs.
Dept. G Cleveland, Ohio

FAIRBANKS, MORSE & CO.,

Gas and Gasoline Engines.
Chicago, Ill.

FIELD-BRUNDAGE CO., THE,

Gas and Gasoline Engines.
Jackson, Mich.

FISCHER SPECIAL MFG. CO.,

Spark Plugs and Coils.
2076 Reading Road, Cincinnati, O.

FOOS GAS ENGINE CO., THE,

Gas and Gasoline Engines.
Springfield, Ohio.

**FORT WAYNE FOUNDRY AND
MACHINE CO.,**

"Wayne" Gas and Gasoline Engines.
Fort Wayne, Ind.

FOX'S REVERSIBLE ENGINE WKS,

Marine, Stationary,
Automobile Engines.
63 W. Eleventh Street, Covington, Ky.

GAS ENGINE WHISTLE CO.,

Whistles and Power Brakes,
1133-B Broadway, New York.

GENERAL COMPRESSED AIR CO.,
Gas Engines and Air Compressors.
3933 Olive Street. St. Louis, Mo.

GEER, HARRY R. CO.,
Motorcycles and Supplies.
1019 Pine St., St. Louis, Mo.

GOODSON ELECTRIC IGNITION COMPANY,
Gas Engine Igniters.
Providence, R. I.

GORDON BATTERY CO.,
Gordon Primary Batteries.
439-445 E. 144th Street, New York, N. Y.

HARDY, R. E., CO.,
"Sta-Rite" Ignition Specialties.
225 W. Broadway, New York, N. Y.

HARTIG STANDARD GAS ENGINE COMPANY,
Gas and Gasoline Engines
For Power and Pumping.
14 Commercial St., Newark, N. J.

HENRICKS NOVELTY CO.,
Ignition Magnets.
120 S. Capital Avenue, Indianapolis, Ind.

HERCULES ELEC. & MFG. CO.,
"Wizard Tubular" Magnets.
Indianapolis, Ind.

KENDRICK & DAVIS,
Gas Engine Igniters.
Lebanon, N. H.

LAMBERT, K., GAS AND GASOLINE ENGINE CO.,
Gas and Gasoline Engines.
Anderson, Ind.

M. O. CROSS ENGINE CO.,
Marine and Stationary Gasoline Engines.
Detroit, Mich.

McCLURE - BUCHNER CO.,
Hush Muffler,
911 S. Homan Ave., Chicago, Ill.

McCORD & CO.,
Asbestos Gaskets, Force Feed Lubricators.
1429 Old Colony Building, Chicago, Ill.

MILLER, CHAS. E.,
"The Largest Automobile Supply House
in America."
99-101 Reade Street, New York, N. Y.

MOTSINGER DEVICE MFG. CO.,
Auto-Sparkers.
109 Main St., Pendleton, Ind.

NATIONAL CARBON CO.,
Ignition Batteries.
Cleveland, Ohio.

NUNGESSER ELECTRIC BATTERY COMPANY,
Ignition Batteries.
Cleveland, Ohio.

O. K. GAS ENGINE WORKS,
Gas and Gasoline Engines.
Winchester, Ohio.

OLDS GASOLINE ENGINE WORKS,
Gas and Gasoline Engines.
212 River Street, Lansing, Mich.

OTTO GAS ENGINE WORKS,
Gas Engines and Gas Producers.
Philadelphia, Pa.

PATTERSON, GOTTFRIED & HUNTER, LTD.,
Friction Clutch Pulleys.
New York, N. Y.

PERFECTION MAGNETO CO.,
Igniting Magnets.
Anderson, Ind.

POWELL, WM., CO.,
Gas Engine Valves and Cocks.
Cincinnati, Ohio.

RHODES & CO., JAMES H.
Calcium Chloride for cooling water.
Chicago, Ill.

REMY ELECTRIC CO.,
Ignition Magnets, Dynamos.
First and Sherman Sts., Anderson, Ind.

RICHMOND ELECTRIC CO.,
Gas Engine Electric Generators.
Box 164, Richmond, Va.

RUPRECHT IGNITER & ELECTRIC COMPANY,
Ignition Devices,
Cleveland, Ohio.

SARGENT, C. E.,
Mechanical Engineer, Gas Engine Expert.
1320 First National Bank Bldg.,
Chicago, Ill.

SCHUG ELECTRIC MFG. CO., THE,
Spark Colls, Etc.,
Detroit, Michigan.

SHEPARD LATHE CO.,
Foot and Power Lathes, Planers,
Shapers, Drill Presses.
121 W. Second Street, Cincinnati, O.

SMITH GAS POWER CO.,
Suction Gas Producers.
Lexington, Ohio.

SOUTHERN MACHINE MFG. CO.,
Two Cycle Stationary Engines.
Richmond, Va.

SPRINGFIELD GAS ENGINE CO.,
Friction Clutch Pulleys.
Springfield, Ohio.

STRANG ENGINE CO.,
Kerosene and Gasoline Engines.
140 Dearborn Street, Chicago, Ill.

STRELINGER, THE CHAS. A., CO.,
"Casalloy" Igniter Points.
Box G411 Detroit, Mich.

TEMPLE PUMP CO.,
Stationary and Marine Engines.
Chicago, Ill.

UNION DROP FORGE CO.,
Crank Shaft, Valve, etc., Forgings.
70-72 E. Ohio Street, Chicago, Ill.

WESTERN GAS ENGINE CO.,
Gas and Gasoline Engines.
Los Angeles, Cal.

WILE GAS POWER CO.,
Automatic and Suction Gas Producers.
212 Cutler Building, Rochester, N. Y.

C. E. SARGENT, M. E.,
1320 First National Bank Bldg., CHICAGO, ILL.
Member W. S. Engineers, A. S. M. E., Franklin Institute,
Etc. Makes a specialty of gas engine calibration and tests.
Thermal and mechanical efficiency obtained, calorific value
of fuels determined.

SATISFACTION GUARANTEED.

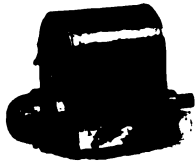

Remy Magneto

No batteries, No spark coils, no wiring, no trouble when using this apparatus. Specify

Remy Magneto

when ordering next year's car and be assured of reliability. Write

REMY ELECTRIC CO., ANDERSON, IND



K & D. GAS ENGINE IGNITER

This generator is self-contained, entirely closed and water tight. All parts are extremely well made interchangeable and easily duplicated. Furnished with friction or grooved pulleys, solid or tilting base. Send for catalogue No. 7 describing igniter in full.
Kendrick & Davis, Lebanon, N.H.

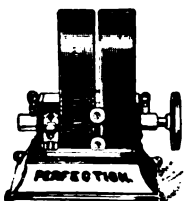

Perfection Magneto

Acknowledged by all users of gas and gasoline engines to be the very best igniter made.

In more general use than any other make. Send for catalogue and prices to

Perfection Magneto Co.

Anderson, Ind.

Mention THE GAS ENGINE.

"We Build 'em — All Sizes"

Our new 2 H.P. marine engine has features that will interest you. And the price is right. We build stationary engines, as well as marine types. Send for our circular.

M. O. Cross Engine Co.,

Atwater Street, - - - DETROIT, MICH.

"The Little Wender"

Engine is the simplest built, having No Valves, and but three moving parts. Will burn either Gasoline or Kerosene (Coal Oil) Oil as fuel. Prices, 3 H.P. Single Cylinder, \$125 00, Six H.P. Double Cylinder, \$250 00. Agents wanted. Manufactured by the

Southern Machine Mfg. Co. Richmond, Va.

CALCIUM CHLORIDE

for COOLING WATER.

Won't freeze · won't rust or affect metal; don't evaporate or precipitate. Used in automobiles and gas engines. Write for our circular.

JAMES H. RHODES & CO. - Chicago

Fischer Spark Plugs

\$1.00 Each.



They can't sputter. The tapered air space prevents it.

Send for Circular of Coils and Plugs.

Fisher Special Mfg. Co., 2076 Reading Rd., Cin., O

ALTERNATING CURRENT MAGNETO

Something New and Free from Complications.

SPARK COILS. One inch spark with four cells.

Coils for Wireless Telegraphy.

X Ray Apparatus of all kinds.

Ruprecht Electrical Co., Cleveland, O.

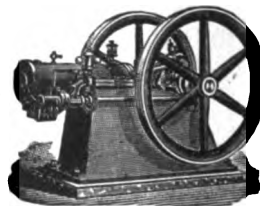

Columbus Engines

GAS and GASOLINE

Send for Catalogue No. 21.

Columbus Machine Co.
COLUMBUS, O.

— GET A —

"HUSH" MUFFLER

For that noisy exhaust. Money back if not satisfactory. For Automobiles, Marine and stationary.

McCLURE-BUCHNER CO.

911 S. Homan Avenue, - - - CHICAGO ILL.

MENTION "THE GAS ENGINE" WHEN WRITING TO ADVERTISERS.

DON'T BUY GASOLINE ENGINES UNTIL YOU HAVE INVESTIGATED "THE

MASTER WORKMAN." a two-cylinder gasoline engine superior to all one-cylinder engines. Costs less to buy, and less to run. Quicker and easier started; has a wider sphere of usefulness. Has no vibration, can be mounted on any light wagon as a portable. Weighs less than half of one-cylinder engines (Give size of engine required. Especially adapted for irrigation in connection with our centrifugal force pumps. (Sizes. 2, 2½, 4, 5, 6, 8, 10, 12 and 16 horsepower.) High-grade Gasoline Engines, 3 to 6 horsepower, adapted for Electric Lighting, Marine and Pumping purposes. **PLEASE** mention this paper. Send for catalogue. **THE TEMPLE PUMP CO.,** Mfrs., Meagher and 15th Sts **CHICAGO, ILL.** Established 1862.

POWER FROM ORDINARY KEROSENE

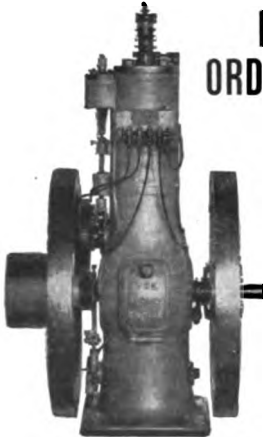

This highest grade engine is strong, handsome, simple, smooth running, quiet, economical and starts instantly. Burns ordinary Kerosene, Gasoline or distillate without change of parts, also equipped to burn gas if desired. Electric ignition, four cycle, direct pump sight feed and no insurance troubles. Specially geared pumping plants, 2500 and 4000 gallons hourly capacity.

Strang Engine Co.
140 Dearborn Street,
Chicago, Illinois.
Works at Harvey, I.I.

HOW WOULD YOU LIKE TO Build your own Motor Cycle?

1½ H.P. Castings, iron cases	\$8 00
1½ H.P. " aluminum cases	12 00
2 H.P. " iron cases	12 00
2 H.P. " aluminum cases	15 00
2½ H.P. " iron cases	15 00
2½ H.P. " aluminum cases	15 00
4 H.P. " iron cases	22 50
4 H.P. " aluminum cases	25 00
5 H.P. double cycle castings, iron	25 00
5 H.P. double cycle castings, aluminum	27 50

We have the finest line of gasoline engine and motor-cycle engine castings on the market. Catalogue sent upon your request upon receipt of five cents to pay postage.



Harry R. Geer Company

1019 Pine Street
ST. LOUIS, MO.

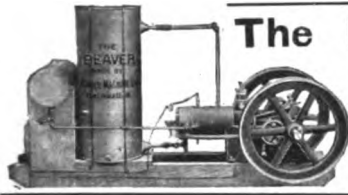

The Beaver

3½ and 6 H.P. GASOLINE Engine Complete, Ready to Run. Agents Wanted. **F. BEAVER MACH. CO.,** 220 E.2d St. Ch'go, Ill.



WONDER GASOLINE ENGINES

Something new and up-to-date. Furnishes more power for less money than any other engine on the market. Two cycle, jump spark, no valves, gears, etc., to get out of order. They are so simple, anyone can operate them.

R. M. CORNWELL CO., Syracuse, N. Y.
Gentlemen: The 1½ H.P. engine purchased of you, called Little Wonder, is appropriately named. I am using it to pump water with complete success. I am able to fill a tank containing 750 gallons at an elevation of 45 feet in 45 minutes and at an expense of less than two cents for fuel. I cheerfully recommend the Little Wonder to all who want cheap, effective and economical power.
J. W. T.

This is a most remarkable showing. You can use the Wonder with the same result. We manufacture engines for any purposes, both marine and stationary, up to five H.P. Send for our complete catalogue. Prices will surprise you. A fine agency proposition for you.

THE R. M. CORNWELL CO., 448 S. Salina Street, SYRACUSE, N. Y.



DON'T BUY until you have seen our Reversible Gasoline Engine. **MARINE, AUTOMOBILE AND STATIONARY** Fox's Reversible Engine Works 68 W. 11th St., - - - Covington, Ky.

"Wizard Tubular" Magneto



STOP all your ignition troubles. We have the remedy. Let us convince you. Send for catalogue and prices to

Hercules Electric & Mfg. Co.
Indianapolis, - Ind.

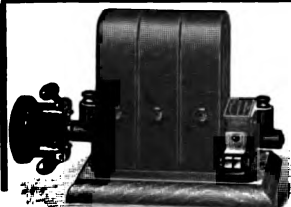

Henricks Magneto Fires your Gas or Gasoline

ENGINE WITHOUT THE AID OF BATTERIES. It is better and more durable than any Dynamo. Its Governor regulates the speed regardless of speed of flywheel. Its Governor adjusts to imperfect flywheels. Its Governor adjusts to imperfect fly wheels. Its Governor insures a constant and uniform spark. The spark does not burn the contacts of the engine. All strains are removed from the bearings of Magneto. Fully Guaranteed. **Henricks Novelty Co.,** 130 S. Capital Ave. Agents Wanted. Indianapolis, Ind.

FOR SALE and WANTS.

Advertisements for this column must invariably be paid in advance. All charges will be made at the rate of 25 cents per line for one insertion. The words "Situation Wanted," "Partner Wanted," "For Sale," the address either advertiser's location or in care of this Magazine, are a part of the advertisement, and will be so counted. Answers to advertisements must be accompanied by 3-cent stamp or stamped envelope, to be forwarded.

If you have an engine to sell; if you require help; if you want a situation, you will secure results by placing an advertisement in this column.

WANTED—An experienced foreman for gasoline engine machine shop. Must have ability to handle fifty men and produce results. Address with references, "Active," care THE GAS ENGINE, Cincinnati, Ohio.

WANTED—Mechanic, with ability to take charge of manufacturing end of well established gas and gasoline engine business in Ohio. Must be capable man who can invest \$3,500 in business. Address C. C. care THE GAS ENGINE, Cincinnati, Ohio.

WANTED—To buy complete sets of castings with drawings, for small marine engines; to be used in instruction work in manual training school. S. C. S. care THE GAS ENGINE, Cincinnati, Ohio.

FOR SALE—15 H.P. Columbus gas engine, complete with all attachments and fixtures except water tank, as engine has been used on city water. Engine is about 3 years old and in good condition. Price, \$400.00. Address "Printing Co." care THE GAS ENGINE, Cincinnati, Ohio.

BARGAINS in second-hand hand gas engines: One 25 H.P. two cylinder Walrath vertical, one 50 H.P. two cylinder horizontal Miller, one 9 H.P. portable Foos on trucks, one 8 H.P. Peerless vertical. For particulars write to The Chas. A. Strelinger Co., Box G 411, Detroit, Mich.

WANTED—Gas engine salesman. An experienced man at desk, able also to go out and close large agency contracts. Address Box 4, care THE GAS ENGINE, Cincinnati, Ohio.

WANTED—Gas engine men. We have room for several gas engine experts familiar with 4 cycle horizontal engines. State salary and experience. Address Box 5, care THE GAS ENGINE, Cincinnati, Ohio.

FOR SALE—8 H.P. automobile engines, air cooled, aluminum base, for \$59.00. Address H. C. March, Portage, Ohio.

FOR SALE. 25 H.P. Struthers-Wells gas engine, with extra valve chest and igniter. Too small for our work. Address Eagle Brass Works, Detroit, Mich.

WANTED. Two experienced Gas Engine Salesmen. Advise fully as to experience and income expected. Address THE FOOS GAS ENGINE Co., Springfield, Ohio.

WANTED. Machine shop foreman. Must be capable, willing to take hold and hustle. Are manufacturing a line of gasoline engines and electrical apparatus and can offer a good position to the right man. Address "Foreman" care THE GAS ENGINE, Cincinnati, Ohio.

FOR SALE. New 5 and 10 H. P. marine engines, price, \$100 and \$190, also second-hand engines 1 to 25 H.P. cheap. See our advertisement on page 15. Fox's Reversible Engine Works, 63 W. 11th Street, Covington, Ky.

FOR SALE. Gas engine factory. We have a line of stationary, gas and gasoline engines from 5 to 50 H.P. Have well equipped machine shop and foundry, with 3 acres of ground. In 1904 we did \$30,000 worth of business, in 1902 and 1903, six percent dividends were paid. Owing to improvement made in 1904 no dividend was declared. None of our stockholders are mechanical men, and as we have recently lost our manager, we desire to secure a competent manager for the factory on salary; or will sell all or a portion of the plant to such a man. In case of purchase will make payments extending over two years if desired. We have a good plant, a good line of engines, a good location. This is an opportunity that will bear investigation. Address "Factory" care THE GAS ENGINE.



A Look in Advance

Do not wait until an accident happens before learning why it occurred. Study the mechanism of your machine and watch for those things which lead up to such disasters. There is no other book published that can so fully inform you and help you as HOMER'S AUTOMOBILE DICTATOR. Sent post-paid on receipt of \$2.00.

THEO. AUDEL & CO.
No. 63 5th Avenue, New York City

THE DRAFTSMAN

A Monthly for ALL Draftsmen,
Especially fine for Students in DRAWING.

10c a copy. \$1.00 a year.
Send for Premium Lists.

Lock Drawer O. CLEVELAND, O.

IGNITION MATERIAL



HERZ & CO., 187 Elm St., New York, N. Y.



LATHE and PLANER TOOLS

THE NEW KIND.

Using Inserted Cutters of Self-Hardening Steel.
ARMSTRONG BROS. TOOL CO. 102 N. FRANCISCO AV., CHICAGO, ILL.

MENTION "THE GAS ENGINE" WHEN WRITING TO ADVERTISERS.

Suction Gas

By **OSWALD H. HAENSSGEN**

SUCTION GAS PRODUCERS promise to be one of the most important future applications of the gas engine. This book, by an eminent German gas engine expert, was the first work to be published in America on this subject.

It relates to the design, construction, method of operation and care of suction gas producers and producer gas engines.

Cloth Binding

4 Illustrations

90 Pages

PRICE \$1.00,

"It supplies the information which a number of inquiries we have received shows is needed."
—POWER.

"This little book has no waste words and deals with its topics in the simplest and most direct way."—THE AMERICAN MACHINIST.

**The Gas Engine
Publishing Co.**

54 Blymyer Building, Cincinnati, Ohio

Gas Engine Troubles and Remedies

By **ALBERT STRITMATTER**
SECOND EDITION

Explains in simple language the method of operation and care of gas and gasoline engines, tells how to avoid difficulty by intelligent use of the engine and what to do in case of trouble.

A large gas engine company has used about 200 copies, which were distributed among its various agents. Other companies place one in the hands of each of the purchasers of their engines.

CLOTH, 120 PAGES

PRICE, \$1.00

The Gas Engine Publishing Company
Blymyer Building, CINCINNATI, OHIO

The Automobile Pocketbook

By E. W. ROBERTS, M. E.

Member American Society Mechanical Engineers; Author "The Gas Engine Handbook,"
"On Marine Motors and Motor Launches," Etc.

This book was issued in March, 1905, and
has been received with only the best of praise

The following are what some of its reviewers have said of it:

“ HERE is a little volume of 300 pages, not a single page of which any man interested in automobiles or gas engines can afford to pass unread. The author knows his subject theoretically, practically, engineeringly and constructively and he is the only man in this country who does know the subject equally well from each of these four vital points.—THE AUTOMOBILE MAGAZINE.

THIS little book conveys the necessary information which is sought by every operator, and perhaps the designer of an automobile. And all this in language which can be easily understood and free from all higher mathematics.—POWER.

IT is the best small volume on the automobile which we have seen thus far.—THE SCIENTIFIC AMERICAN, (June 24, 1905.)

NO MOTORIST could purchase information likely to be of greater service to him than that contained in Mr. Roberts' latest book.

—THE RAMBLER MAGAZINE. ”

There are chapters on fuel mixing devices, ignition, engine design, radiators, mufflers, transmission gears, wheels, tires, springs, brakes, etc, in fact the book covers thoroughly the subject of gasoline automobile construction and operation. 325 pages, limp leather, 3½ x 5¼, 52 diagrams and illustrations.

PRICE, \$1.50

The Gas Engine Publishing Co.

54 BLYMYER BUILDING, CINCINNATI, OHIO

In Addition To Furnishing Designs

I am equipped to make tests

Gas Engines Tested for brake or indicated horsepower, valve settings, fuel consumption, etc.

Automobiles Tested for speed, power, transmission losses, reliability, hill climbing, tractive effort, etc.

Gases and Liquid Fuels Tested for heating power and in actual service on engines.

TESTS MADE ANYWHERE.

E. W. ROBERTS, M. E.

Member American Society Mechanical Engineers
Author of "The Automobile Pocketbook," "The Gas Engine Handbook," Etc.
Box 321, CLYDE, OHIO

The Gas Engine Hand Book

By E. W. ROBERTS, M. E.

Member American Society Mechanical Engineers, Author "The Automobile Pocketbook,"
"On Marine Motors and Motor Launches."

FIFTH EDITION

SIXTH THOUSAND

THE first edition of this work was issued in the Spring of 1900, since then over 6000 copies have been sold and the demand is as great as ever. No other work has been published which anywhere near equals it, in fact, no similar work has ever been published. ∴ It contains the most complete set of formulas on gas engine design ever published. The accuracy of these formulas has been tested in hundreds of gas engines which have been designed from them. In fact most of the formulas were developed from standard practice in United States gas engine factories. ∴ It has been adopted as a text book in schools and colleges.

264 Pages, Limp Leather, 3½ x 5½,
40 Diagrams and Illustrations.

The Gas Engine Publishing Company

54 Blymyer Building, - - - Cincinnati, Ohio

OFFER No. 18

An Extraordinary Value

A Big Bargain in PERIODICALS

\$6.00 FOR **\$3.00**

A Great Half Price Offer

THE GAS ENGINE	- - - -	\$1.00
THE REVIEW OF REVIEWS	- - -	\$3.00
THE COSMOPOLITAN	- - -	\$1.00
THE WOMAN'S HOME COMPANION	-	\$1.00

A year's subscription to the four periodicals for \$3.00. The greatest magazine combination ever offered. Mail remittance at once. We have secured only a limited number of combination subscriptions.

The Gas Engine Publishing Co.
Cincinnati, Ohio

