

In a recent bulletin published by the association, the editorial – translated here – seemed to me to sum up very conclusively the answers to the question so often asked: ‘Why save the windmills?’

Because men want and wish to know their origins and how their ancestors lived.

Mills had a preponderant place in simple everyday life. They were in effect the objects of many conflicts of right and gave rise to many expressions still used in our times.

Because men are curious about old techniques; think for a moment that these ‘machines’ have not for all practical purposes changed during 600 years – 25 generations.

Because men can once again by using mills utilise two natural sources of energy: water and wind, without using them up and without pollution.

Because men have converted with courage and love these magnificent edifices which in each region of France blend so well with the countryside.

Because men need once again the help of the windmills, to make flour and oil. To saw and turn wood, to grind and mix various products, to pump water for irrigation, to give life to fountains, and many other possible practical uses.

Because men should pass on their heritage to their children and to the men of tomorrow.

FIGURE 7a Gearing and stone layout of post mill with two underdriven sets of stones in the breast.
 FIGURE 7b Gearing and stone layout of 'head and tail' post mill with two overdriven sets of stones.
 FIGURE 7c Gearing and stone layout of post mill with a single stone in the breast.

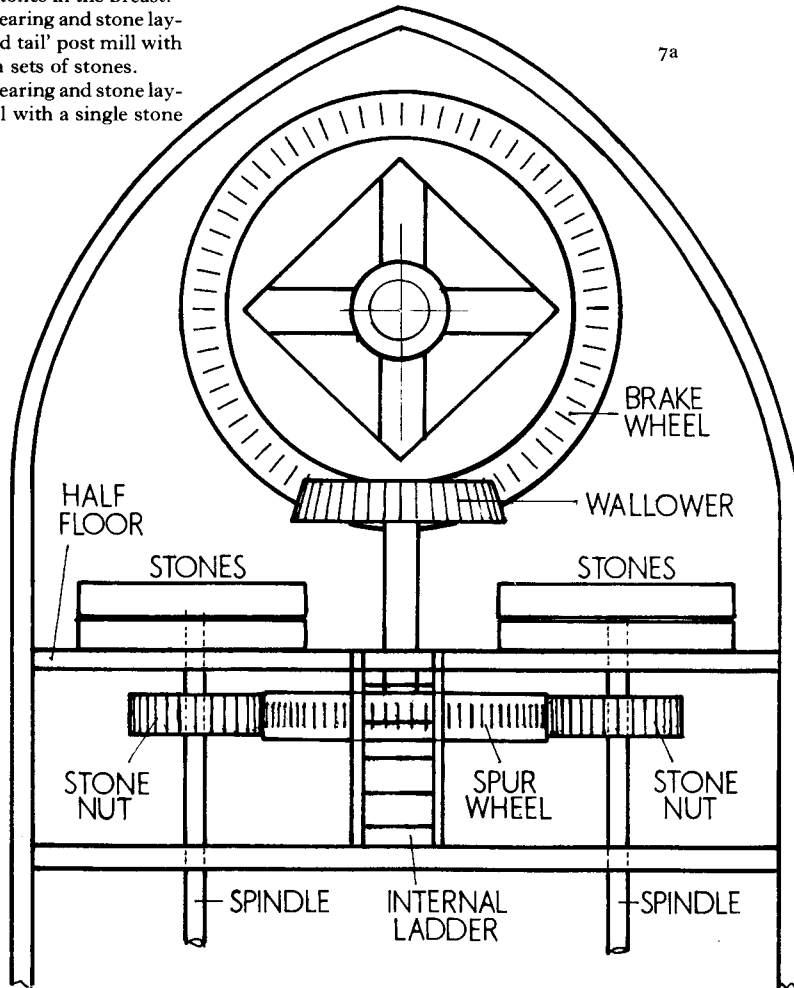

7a

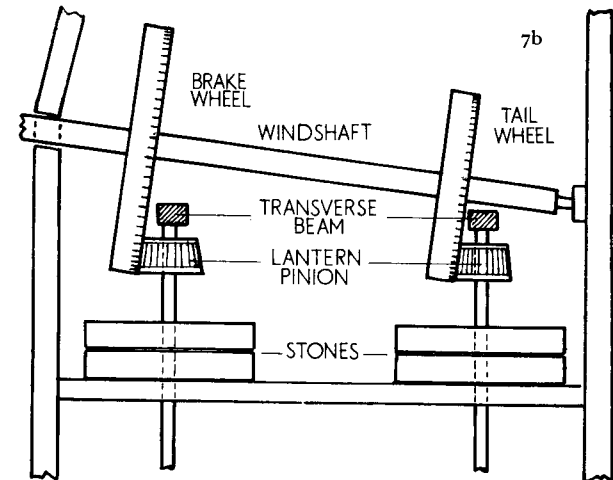

7b

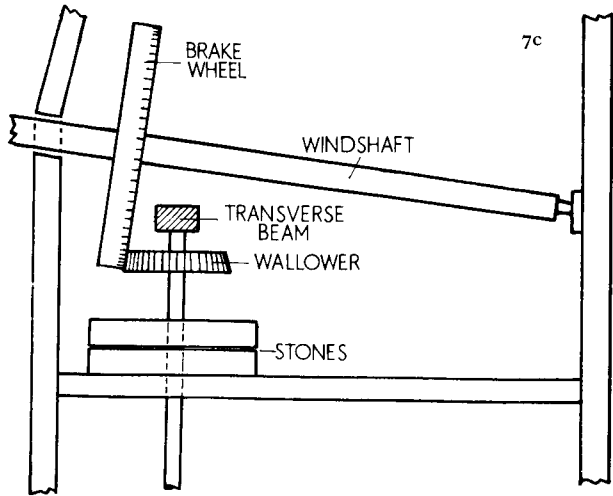

7c

FIGURE 6 Principles of the brake.

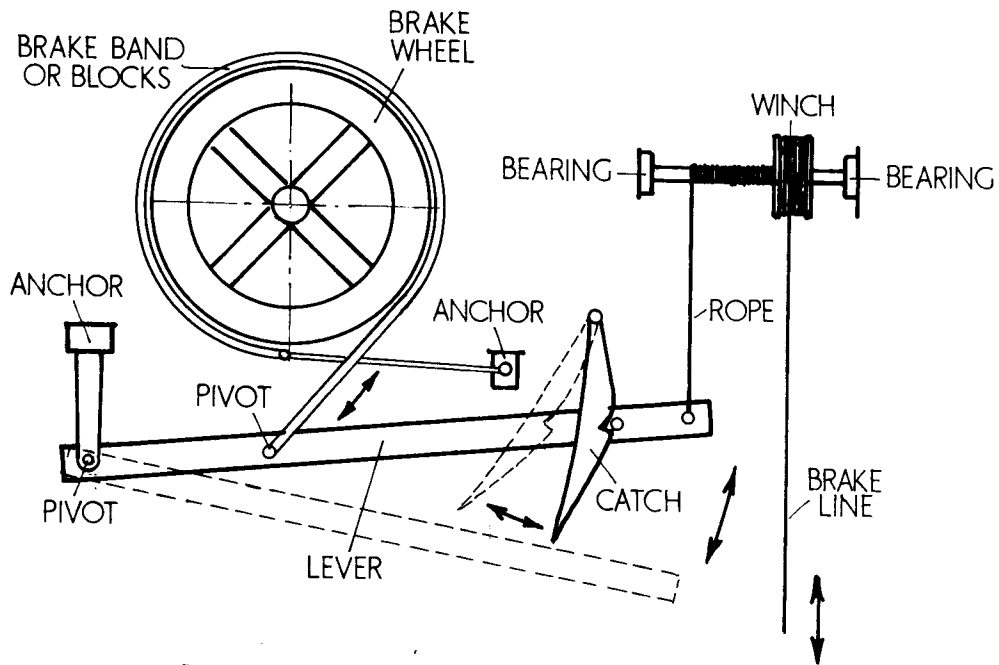
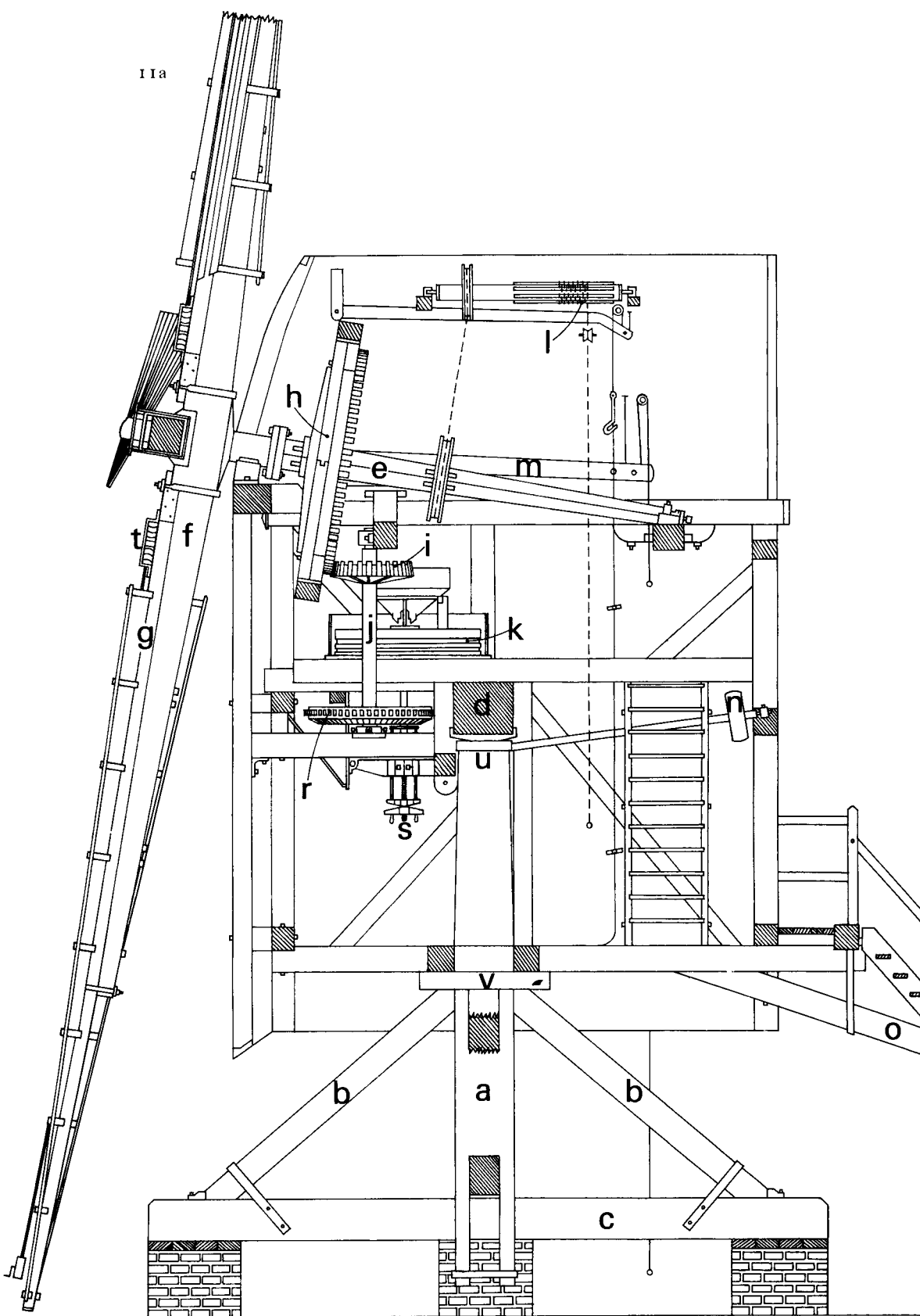
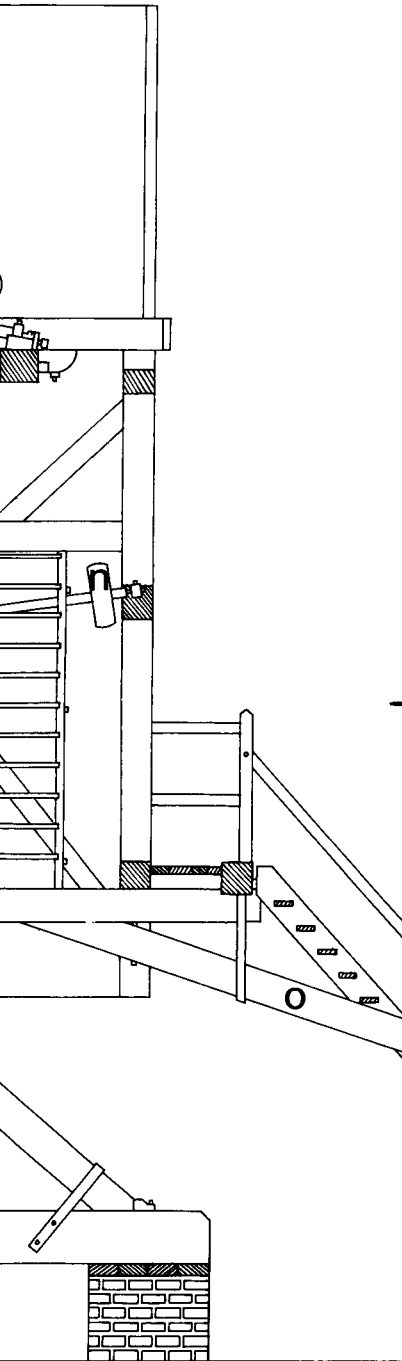

FIGURE 7a Gearing and stone layout of post mill with two under-driven sets of stones in the breast.

FIGURE 7b Gearing and stone layout of post mill with one under-driven set of stones in the breast.

11a





111b

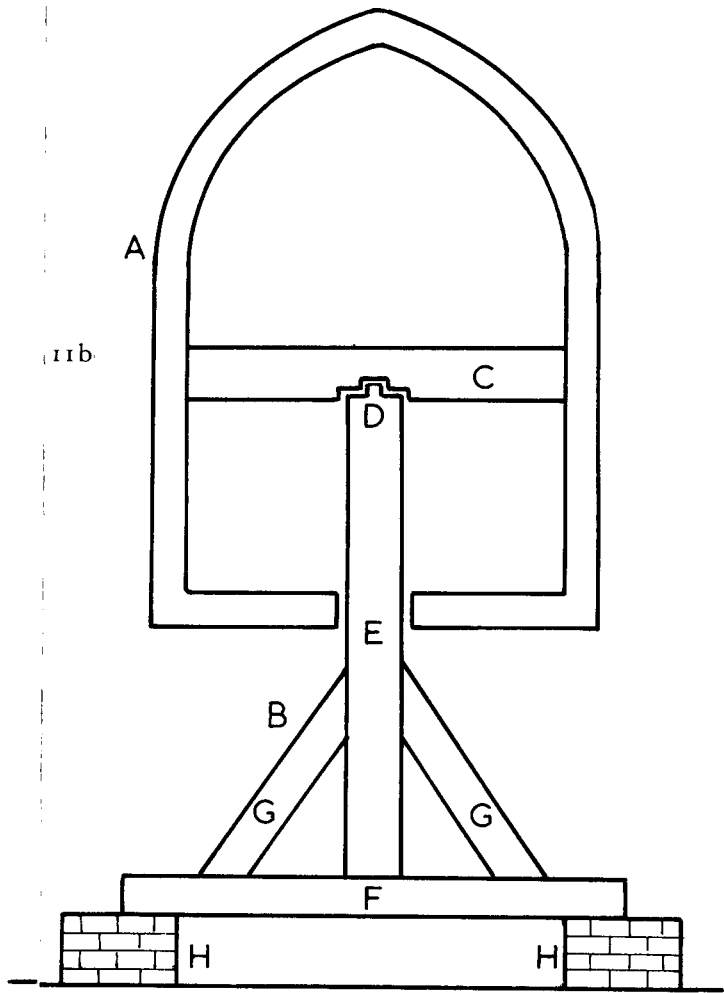

p

q

o

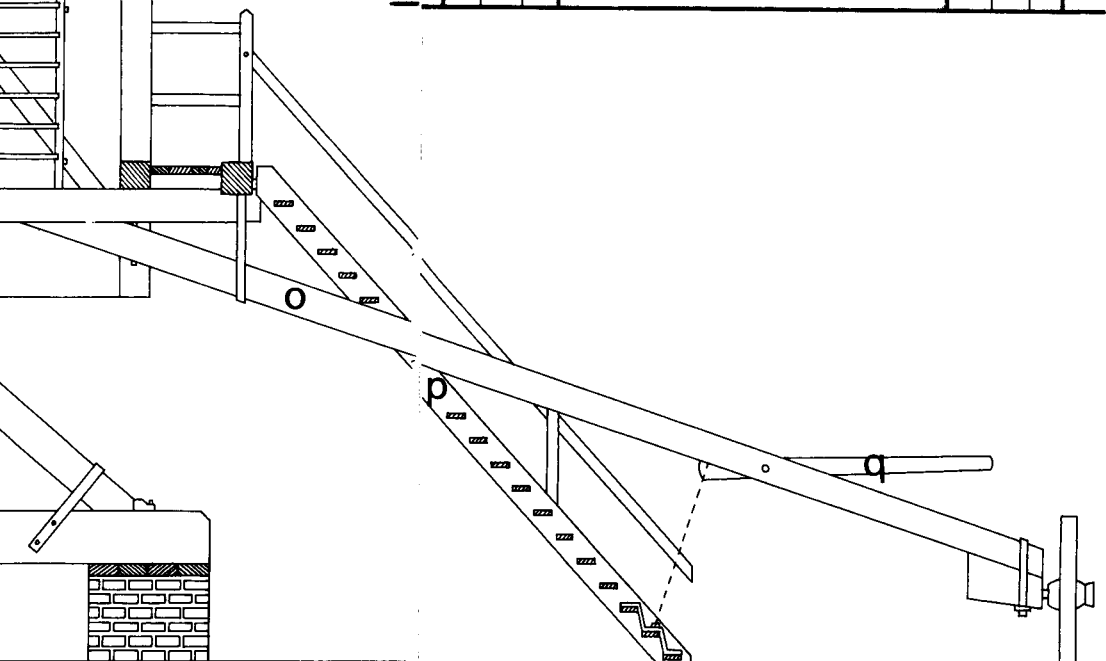
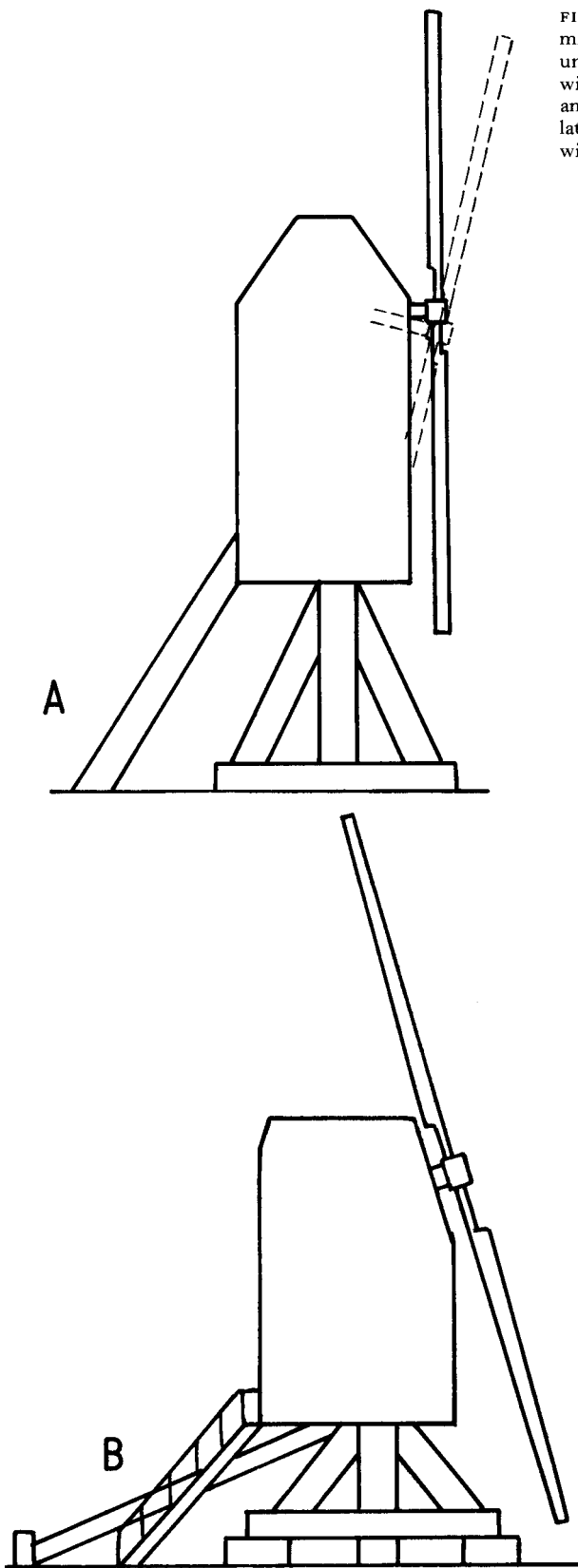

FIGURE 12 Old and new type post mills. A is the early type, clearly unbalanced. Horizontal windshaft will eventually wear its bearings and tip forward. B (below) is the later type obviously well balanced with inclined shafts.



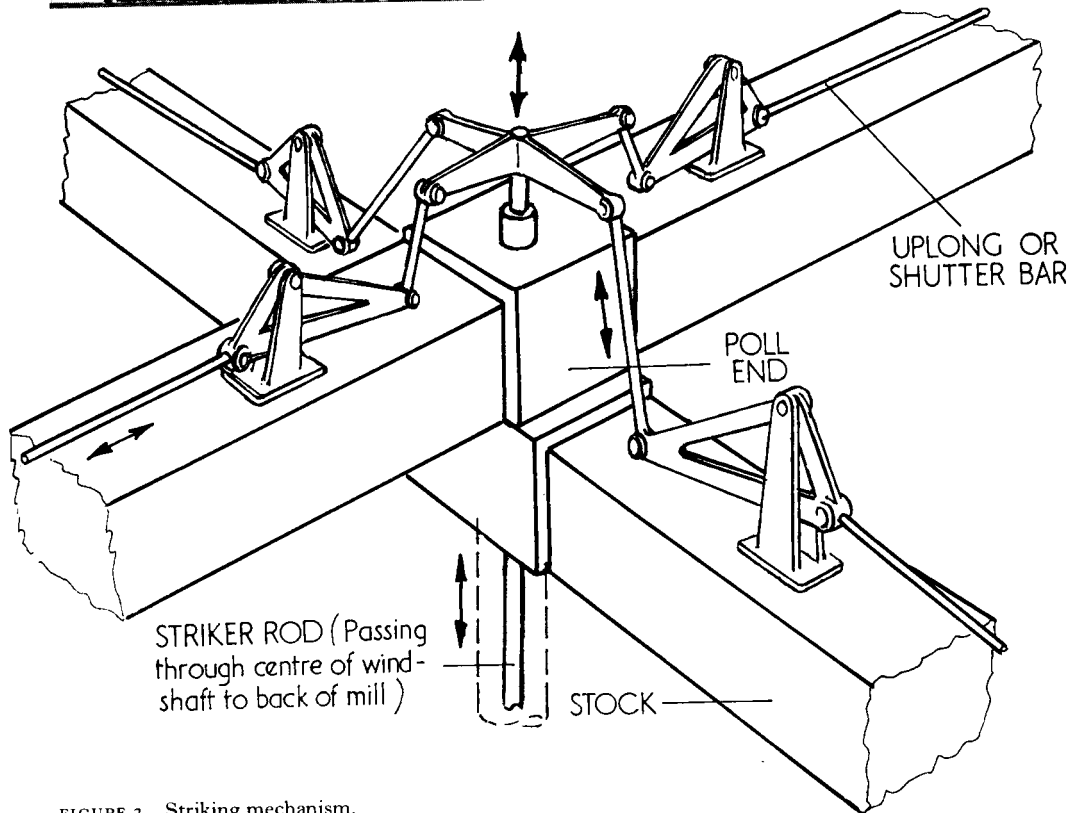
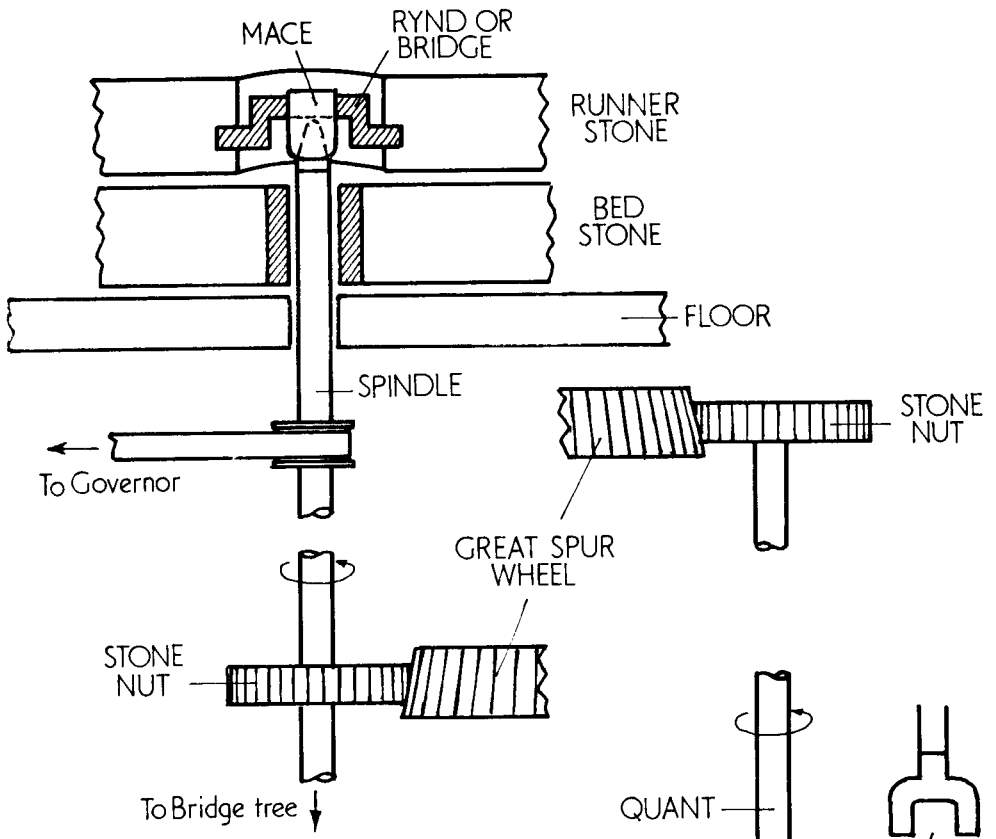

FIGURE 3 Striking mechanism.

A

UNDERDRIFT



B OVERDRIVE

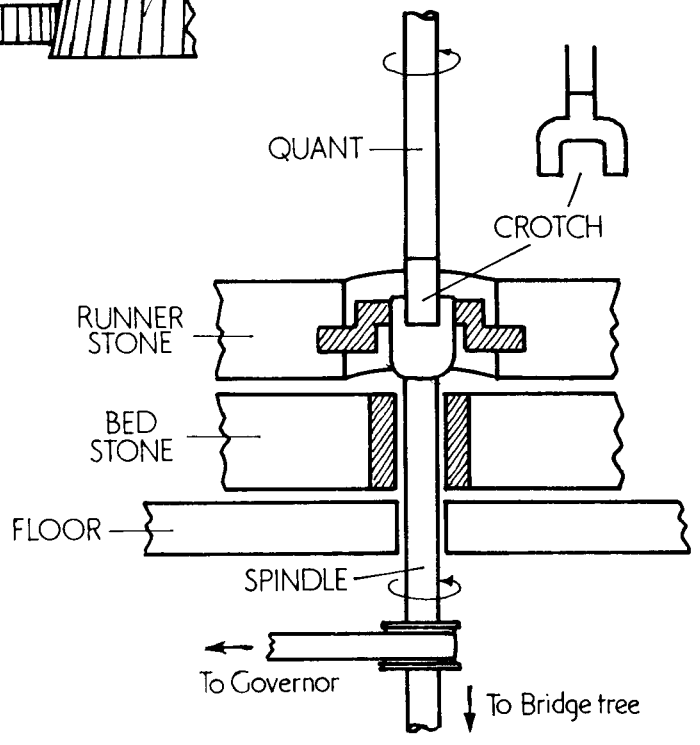

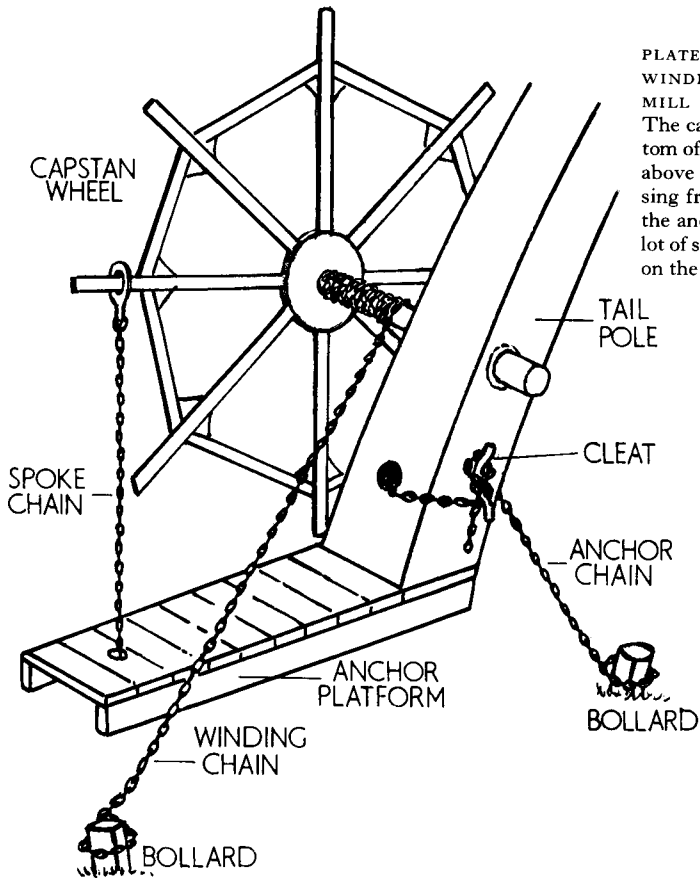
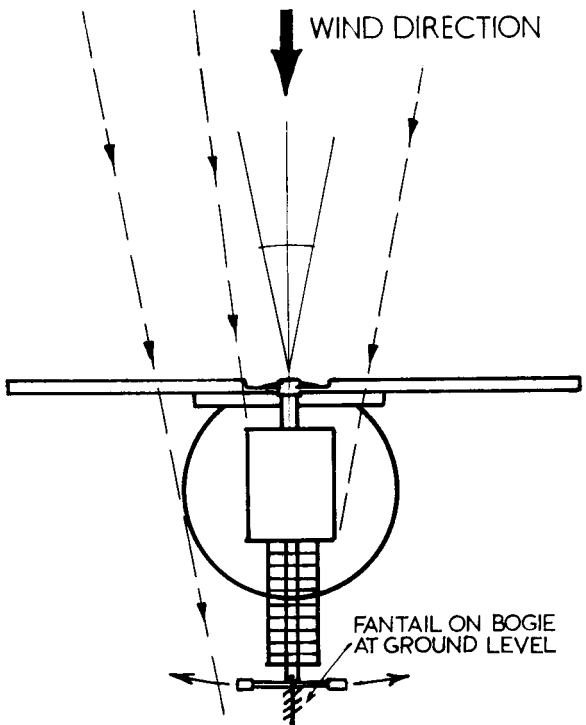
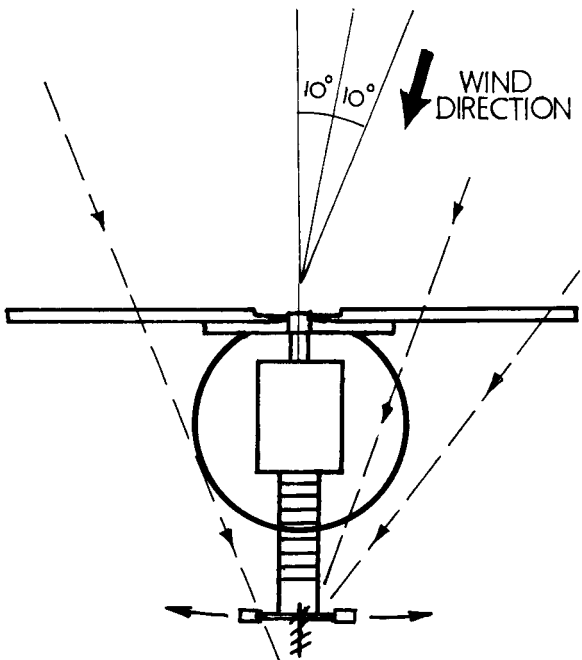

PLATE 32 (inner left)
WINDING CAPSTAN ON A DUTCH
MILL

The capstan is attached to the bottom of the tailpole and ladder, high above ground; note the chain passing from windlass to bollard, and the anchor chain. A man can get a lot of strength to bear pulling down on the capstan arms at this level.



WIND DEAD AHEAD Fantail in lee of mill will not react to winds inside 20° arc. Windmill with patent shutters will work 10° off the eye of the wind.



WIND 10° TO ONE SIDE Fantail on bogie at ground level will react to wind passing side of mill sufficiently to bring mill well within 10° of wind direction.

SOUTH-WEST TRADITION

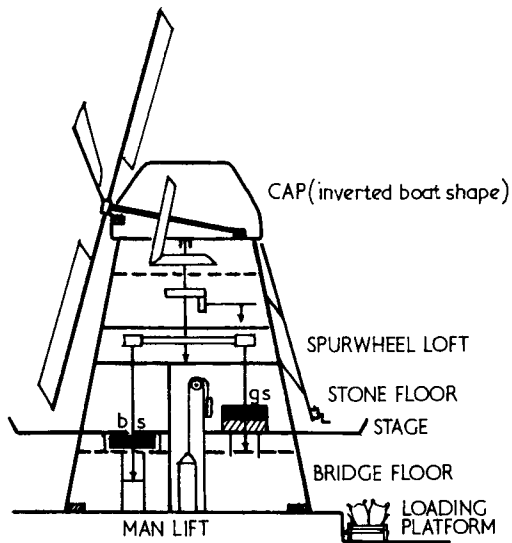

NORTH-EAST TRADITION

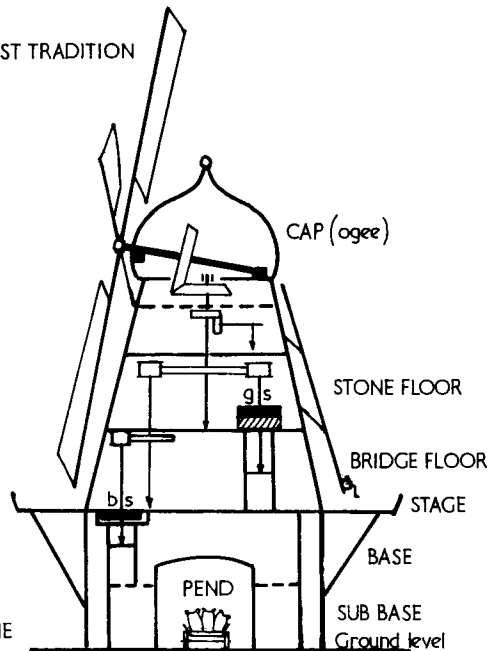

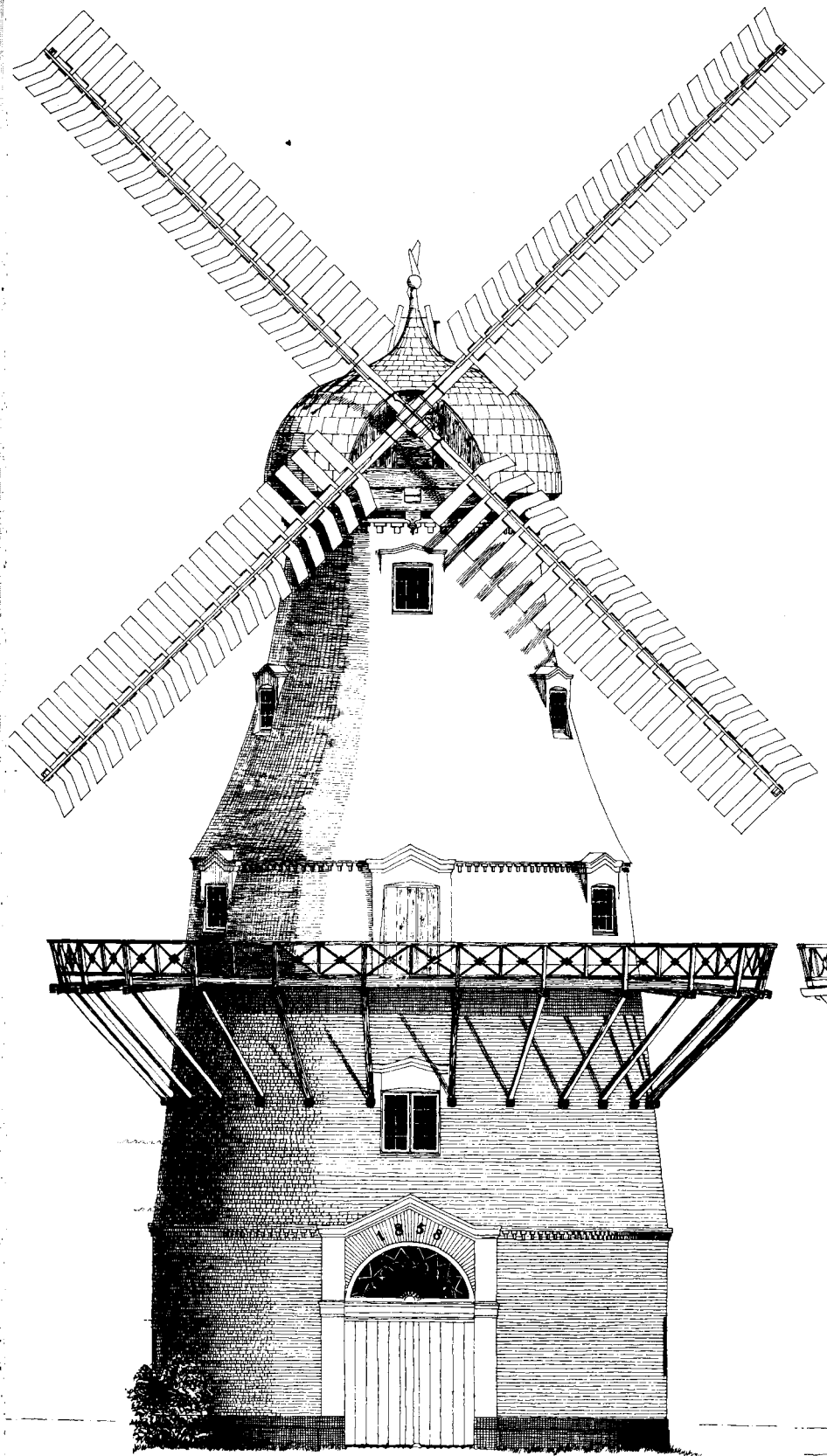
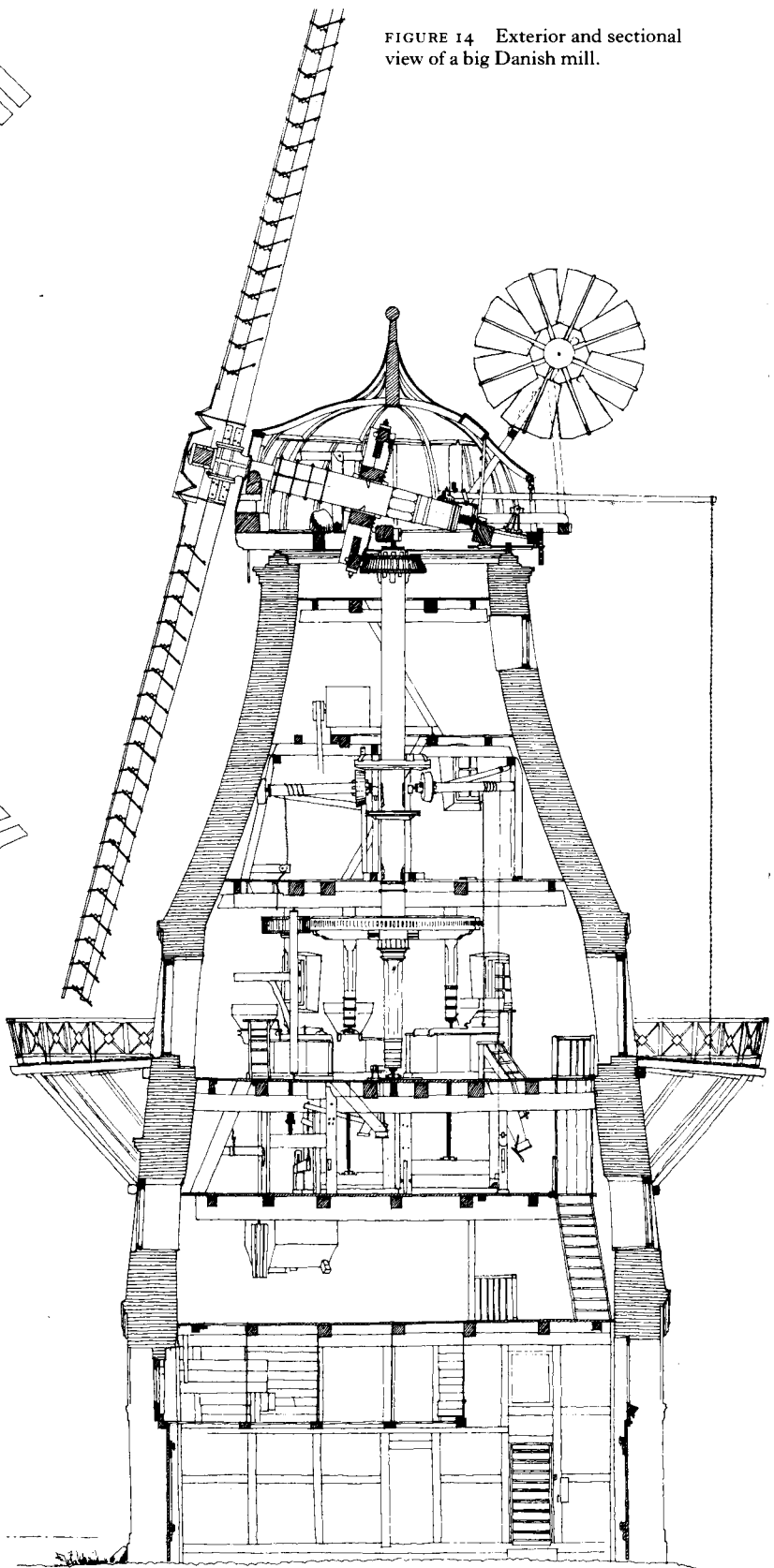

FIGURE 14 Exterior and sectional view of a big Danish mill.



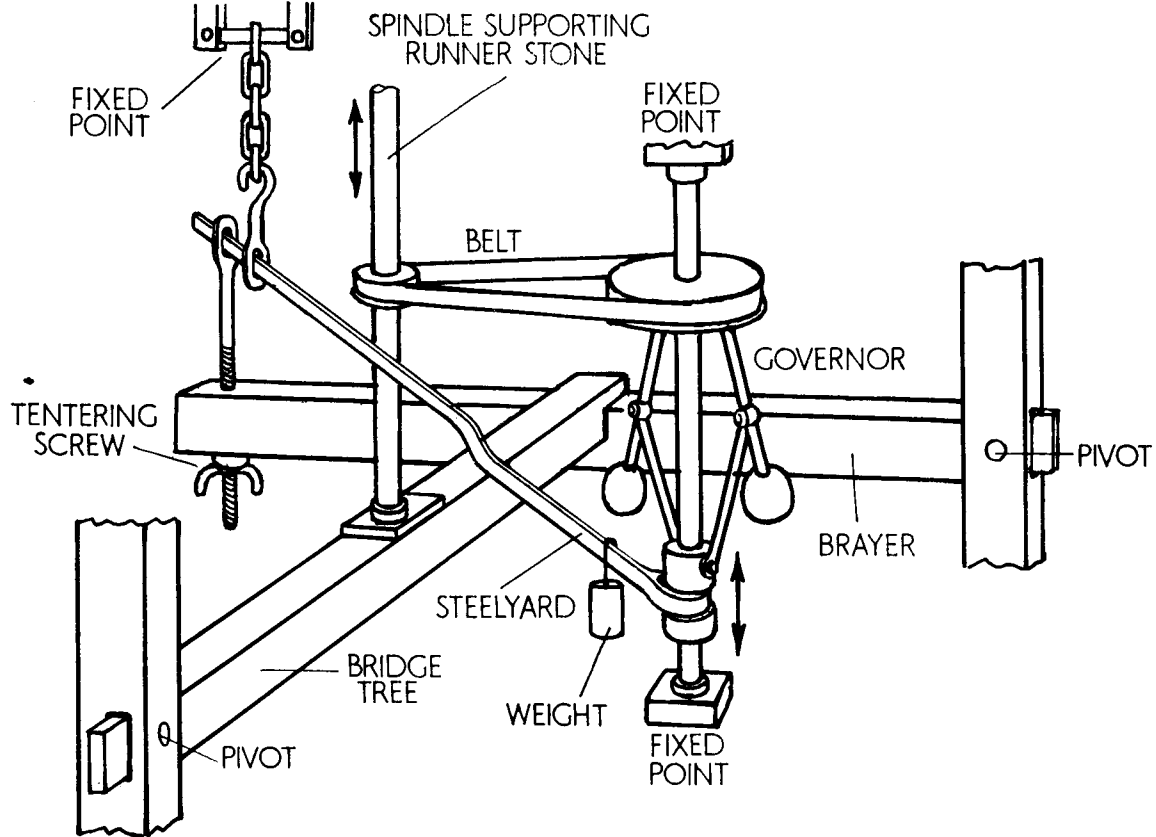
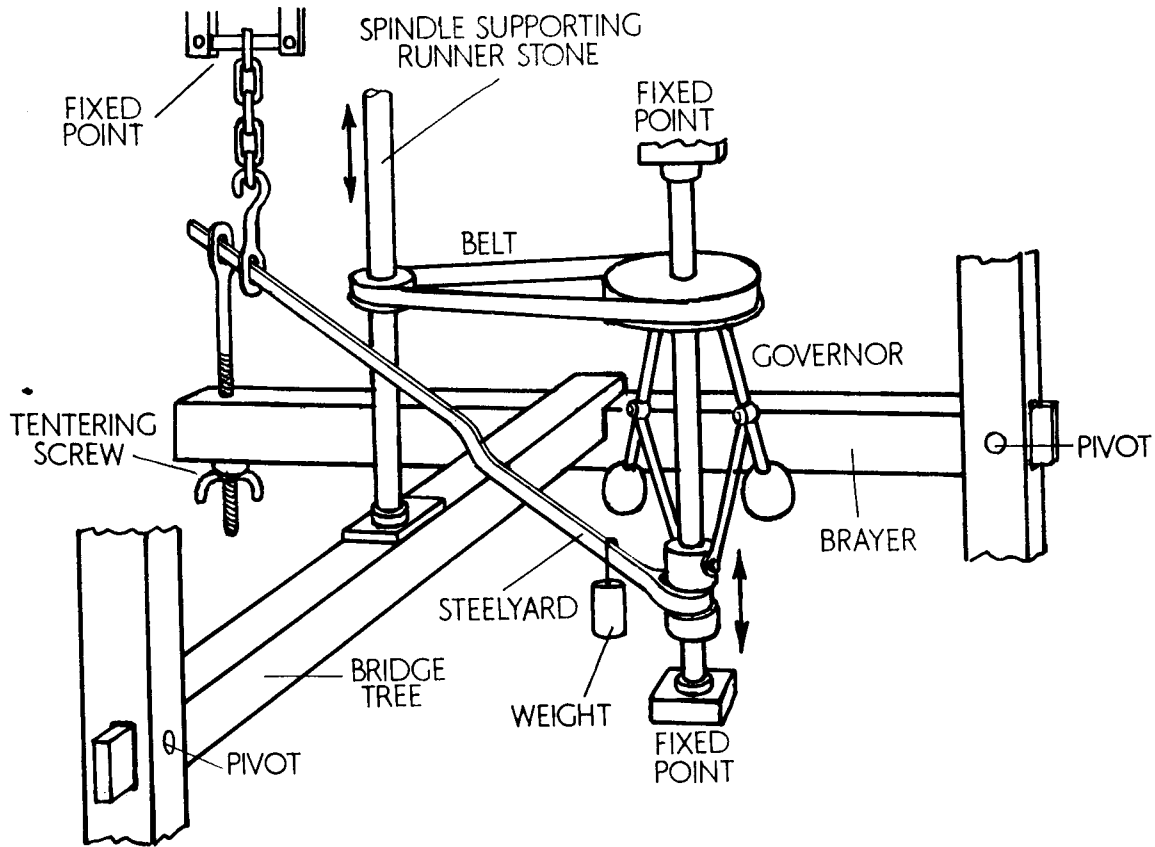
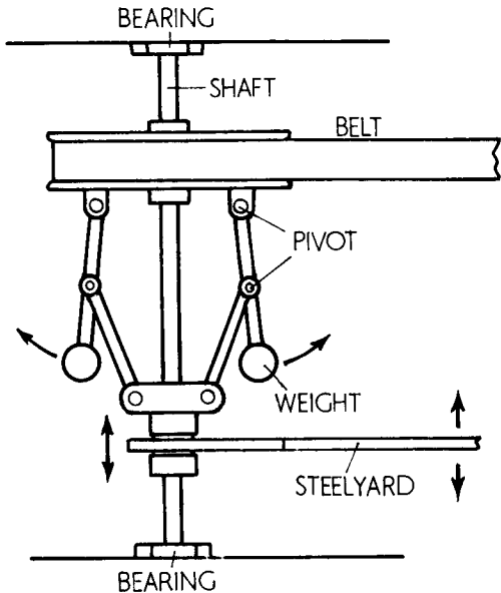

FIGURE 15 Action of governor and tentering screw (diagram not to scale).





TOTAL LIFT OF 15-18 FEET

WIND SHAFT MAKES 2-12 REVOLUTIONS TO TURN SCOOP WHEEL ONCE

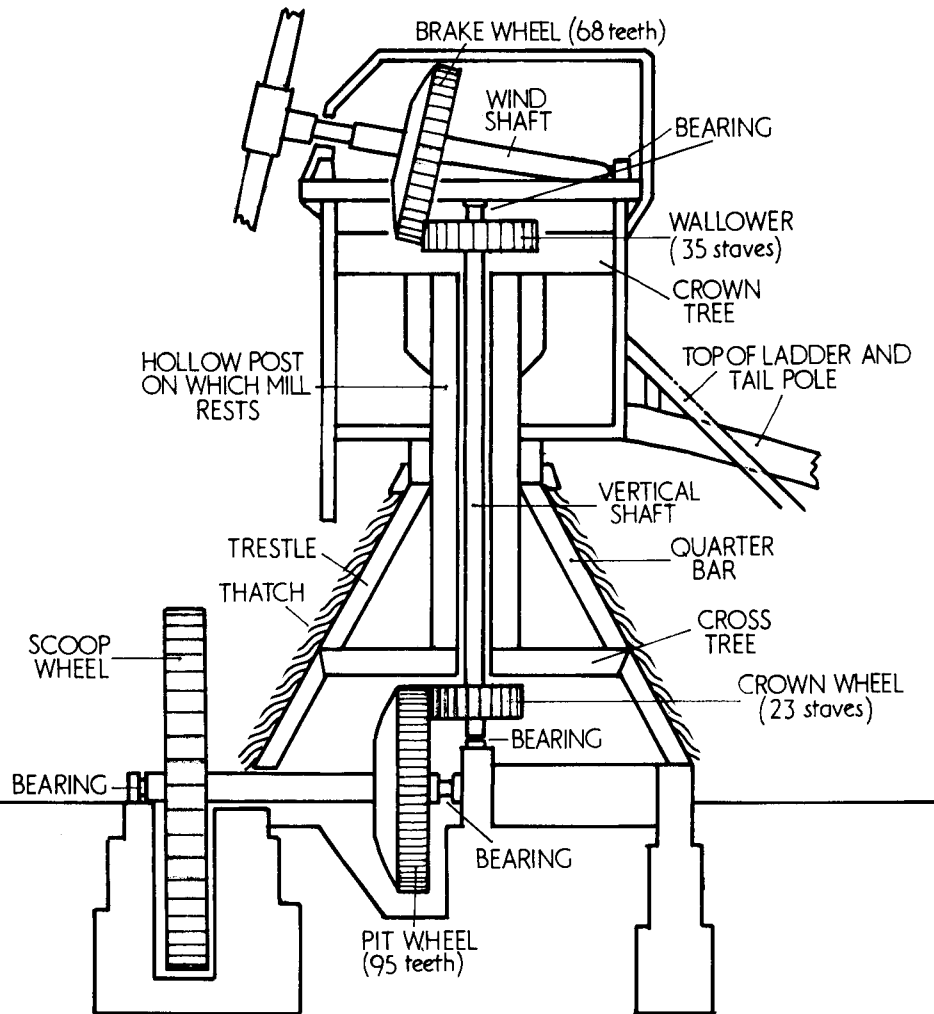

3rd Mill

2nd Mill

1st Mill

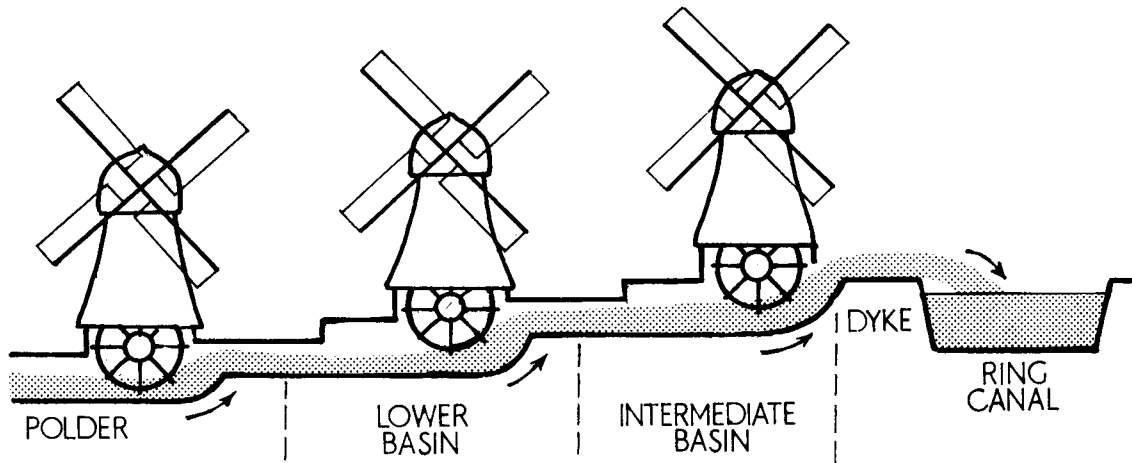

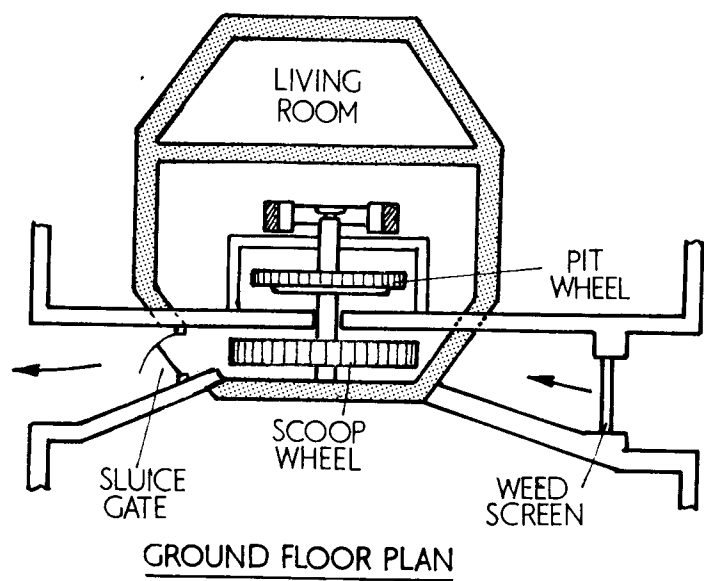
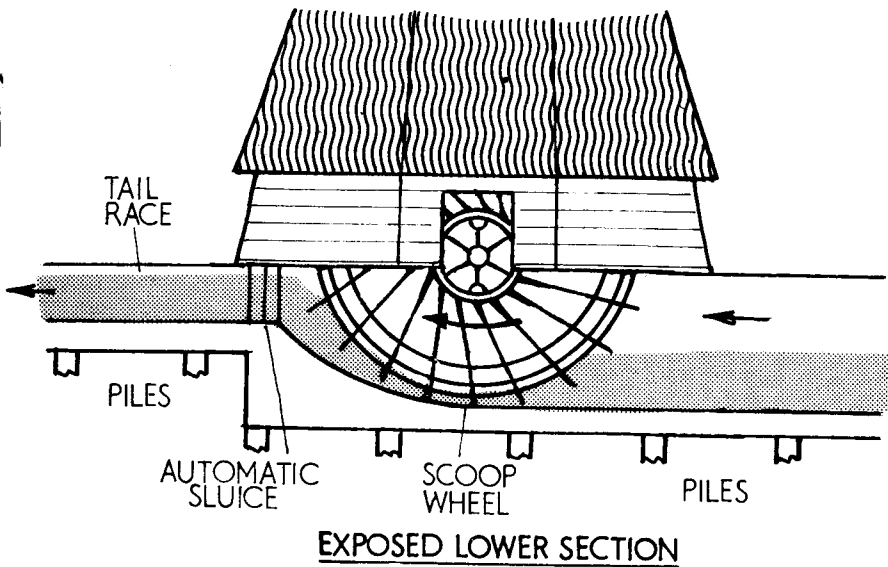

FIGURE 21 Edge mill.

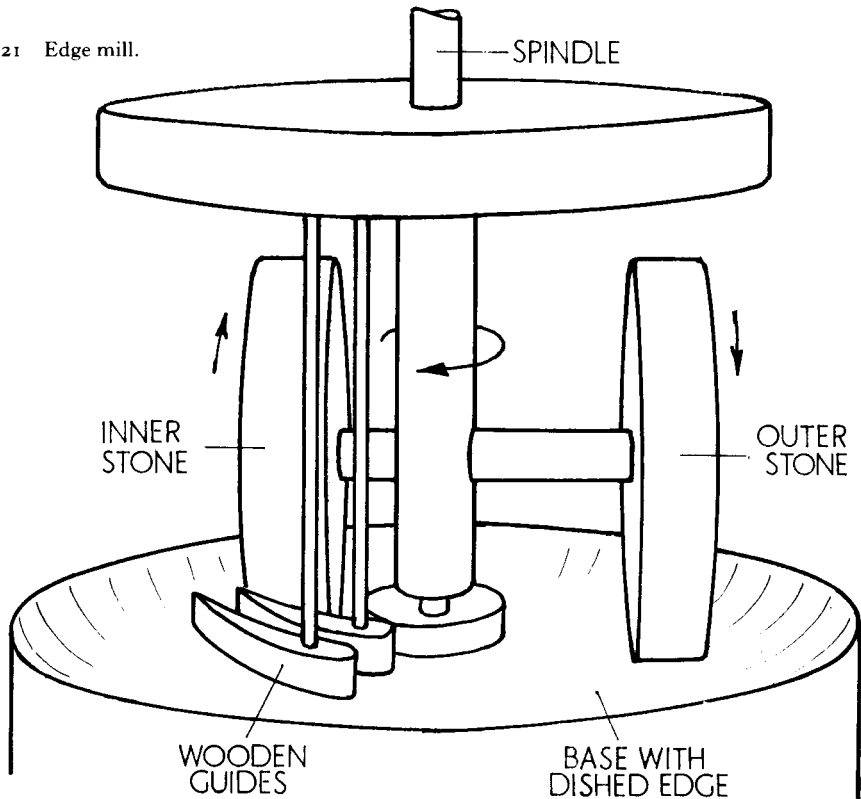

FIGURE 22 (right) Principle of cam shaft and rams.



CAM SHAFT

FIGURE 22 (right) Principle of cam shaft and rams.

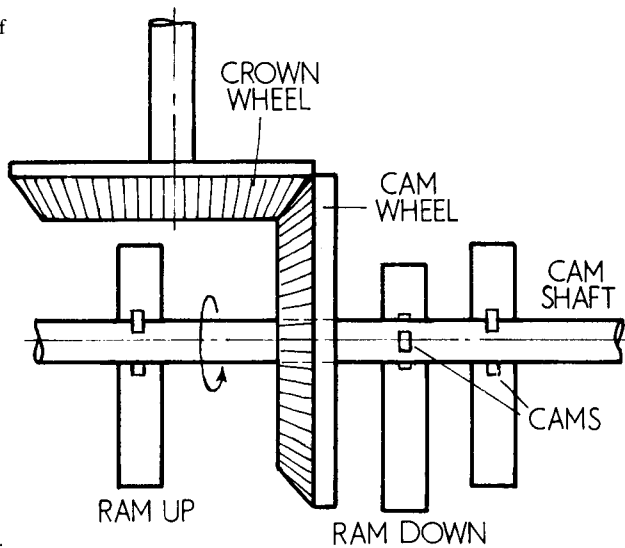
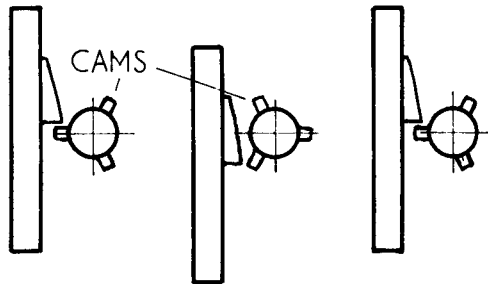
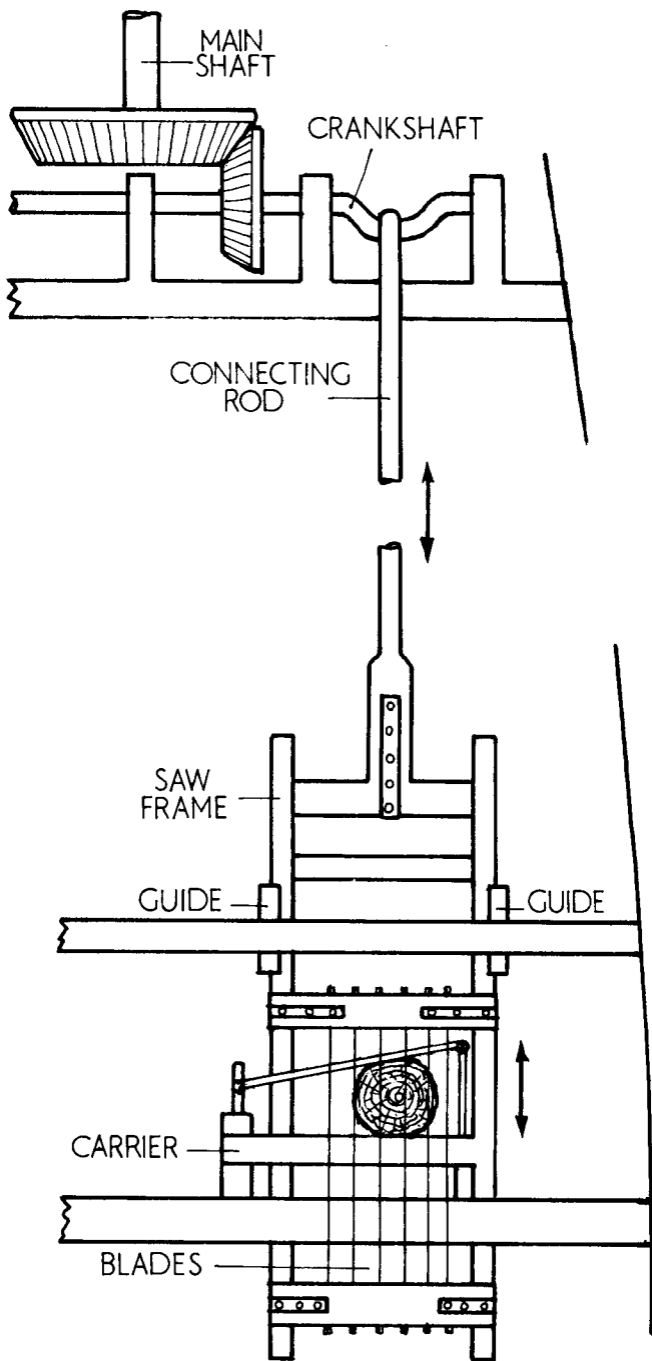
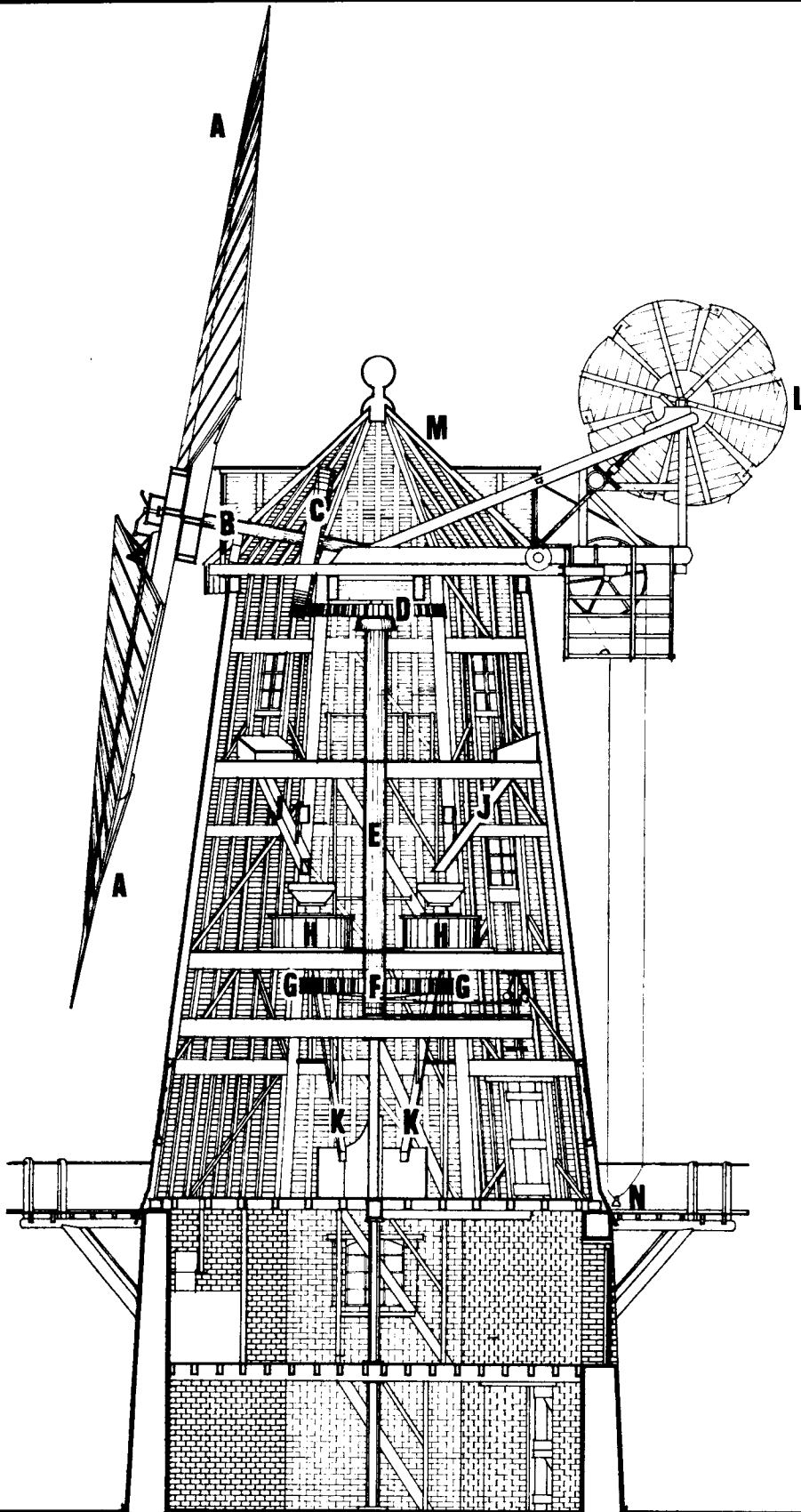

FIGURE 23 (inner right) Saw mill.





frames set in hardwood runners. These saw frames carry vertical blades under tension. The blades can be set at the widths required by the sawyer. The balk of timber to be cut is laid on a carrier, which moves it forward at each upstroke of the saw, by means of a ratchet and pawl wheel with a pinion at its centre gearing into a rack on the carrier. The saws cut on the downstroke only.



- A : Sweeps**
- B : Windshaft**
- C : Windshaft Wheel**
- D : Wallower**
- E : Central Shaft**
- F : Large Cogwheel**
- G : Small Cogwheels**
- H : Stones**
- J : Grain Shoots**
- K : Meal Shoots**
- L : Fan**
- M : Cap**
- N : Weight**

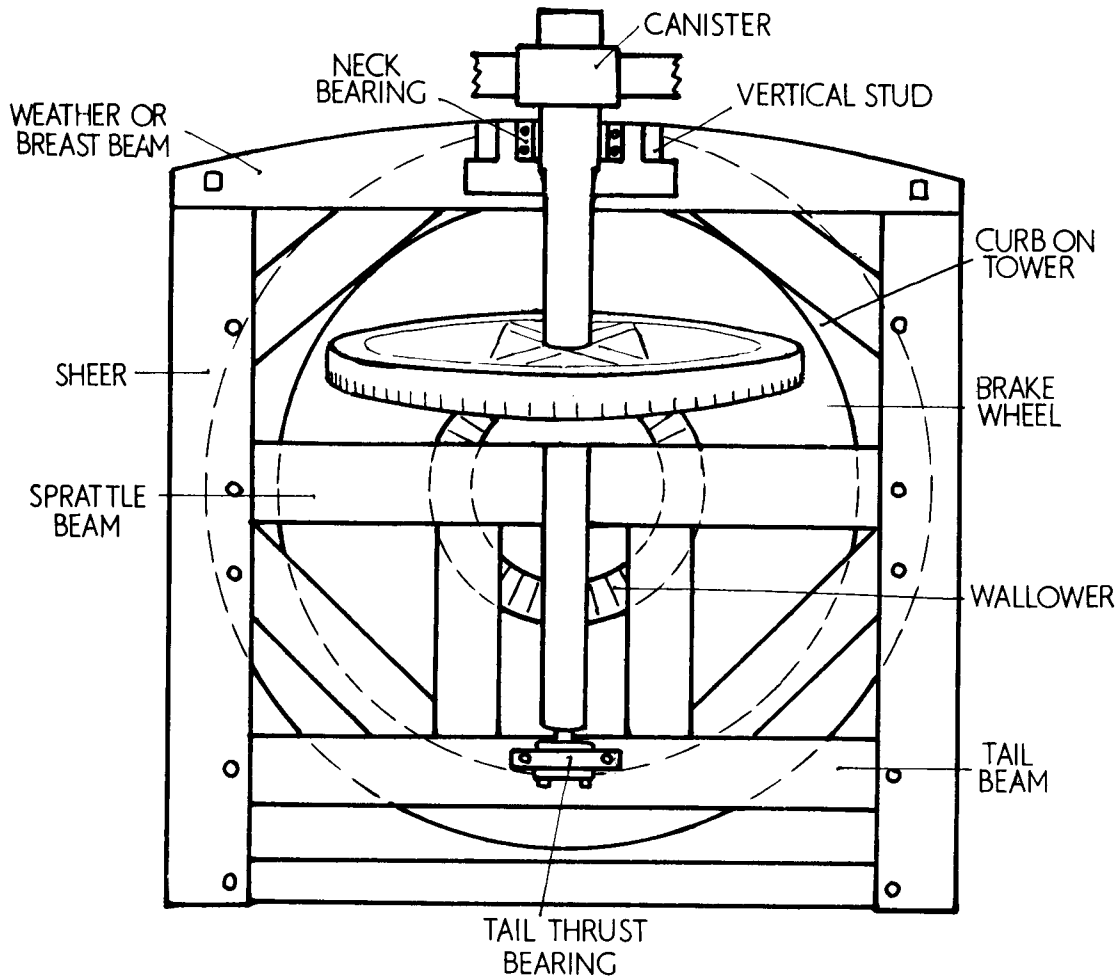

(A)

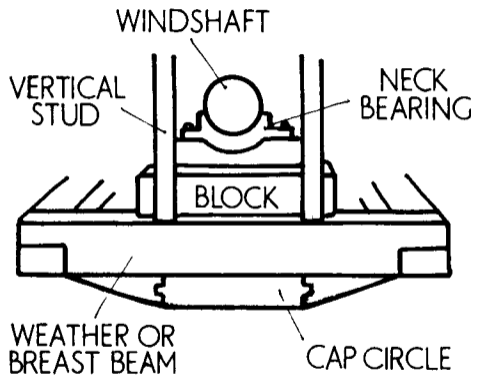

(B)

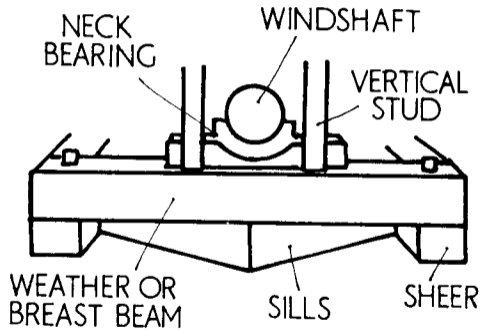

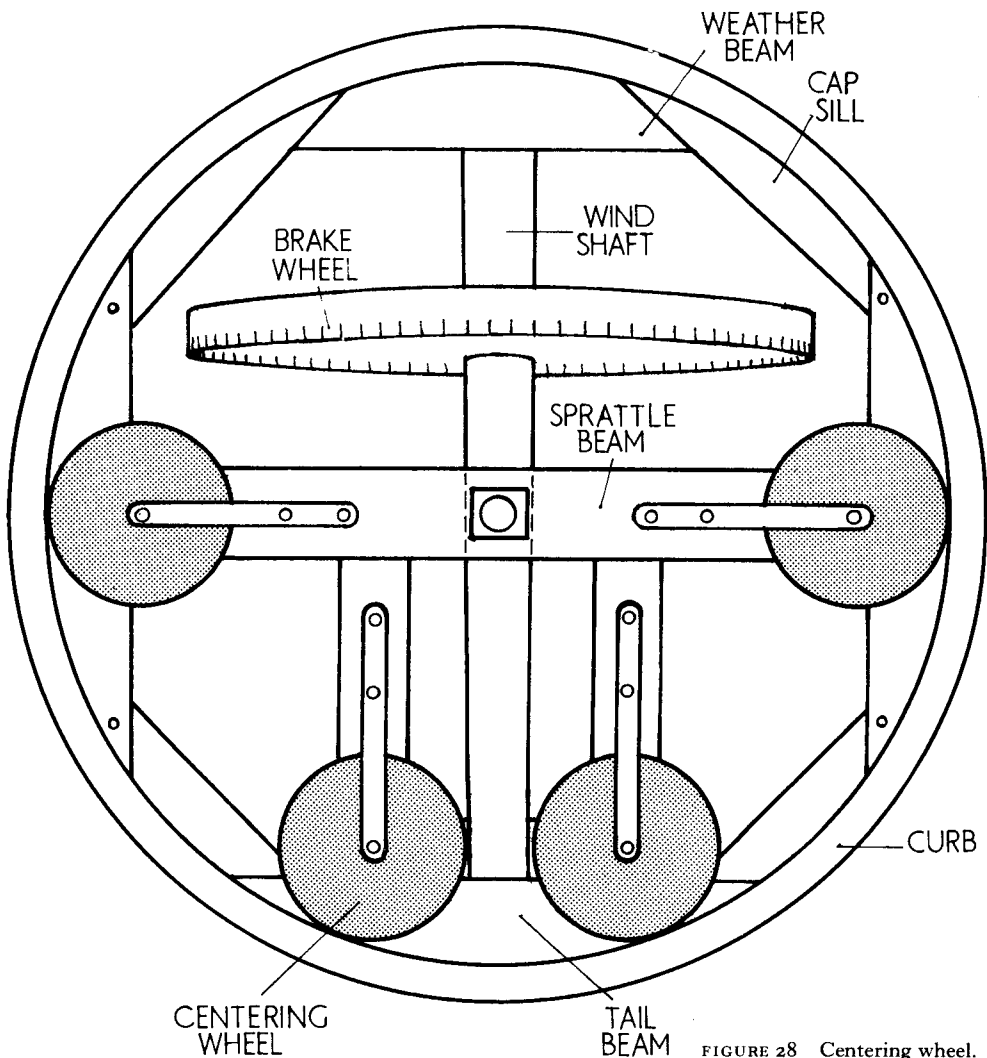
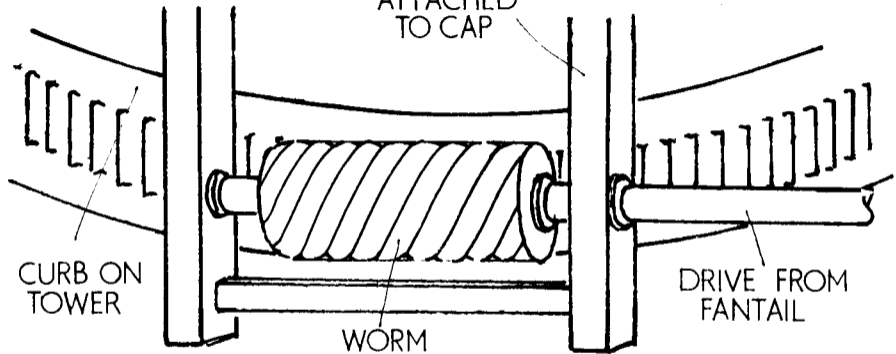

FIGURE 28 Centering wheel.

ATTACHED
TO CAP



CURB ON
TOWER

WORM

DRIVE FROM
FANTAIL

FIGURE 27 Worm and cap cogs.

FIGURE 31 Putting in stocks.

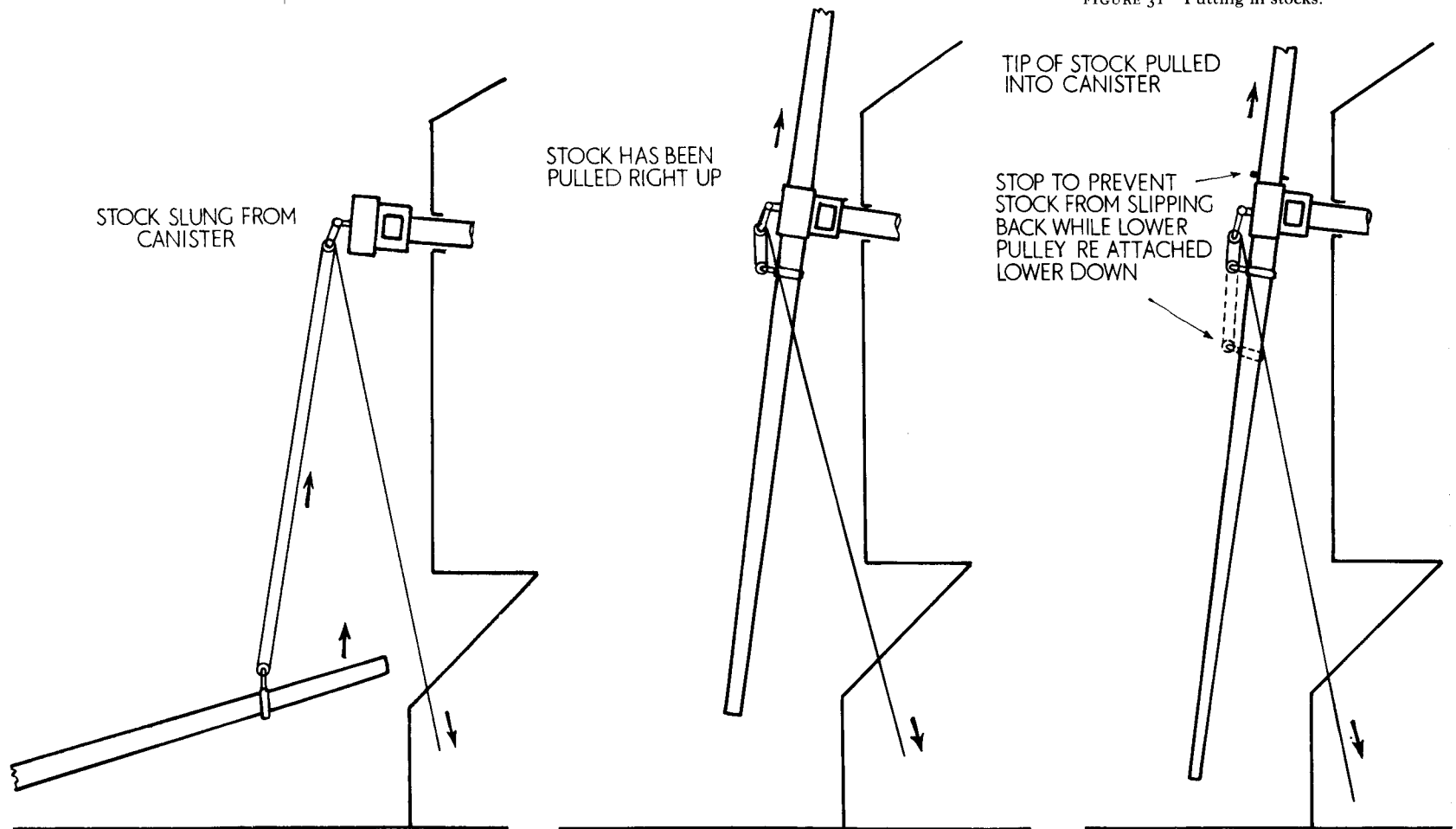



MILL NEAR LA MANGA, SPAIN

This tower mill, with its scalloped boards and massive tailpole, pumped up water and then moved it into irrigation channels by means of a scoop wheel, which is just visible behind the tower. The framework of the wooden poles and wire rigging is in good repair, and one can see exactly how the stresses of the sails were taken. The triangular cloth sails were set on the poles and rigging as the sail of a boat is set on mast and boom.

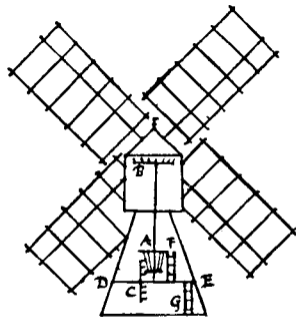
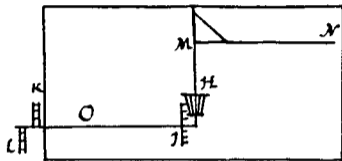

FIGURE 203—An original drawing by Simon Stevin of the drainage-mills described in his patent of 28 November 1589. (Left) Horse-mill driving scoop-wheel through right-angle gears; (right) turret-mill driving scoop-wheel.

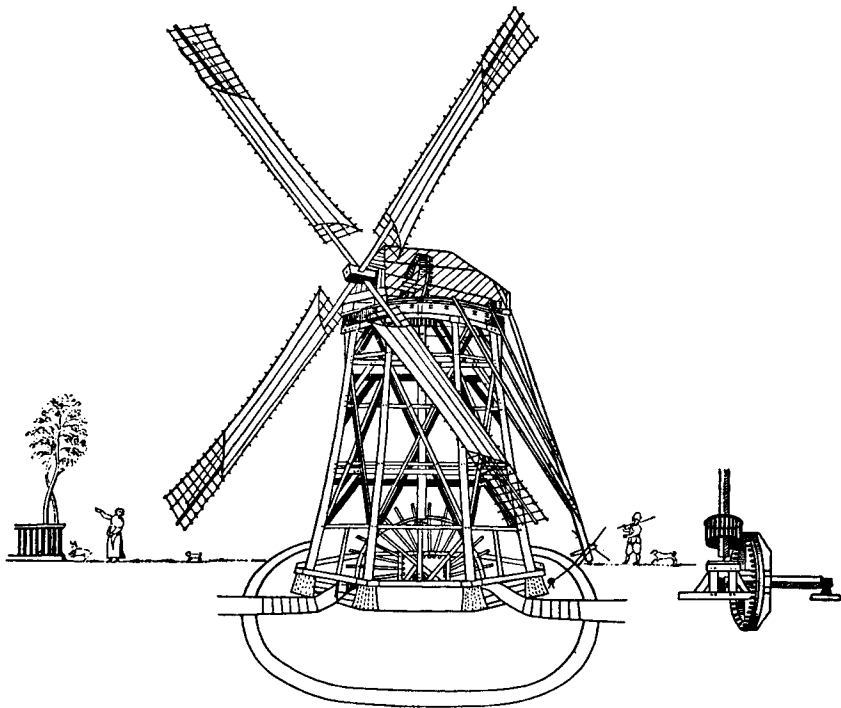

FIGURE 205—Drawing by Leeghwater of a mill used in draining the Beemster polder. The scoop-wheel rotates clockwise and the outflow is to the left.

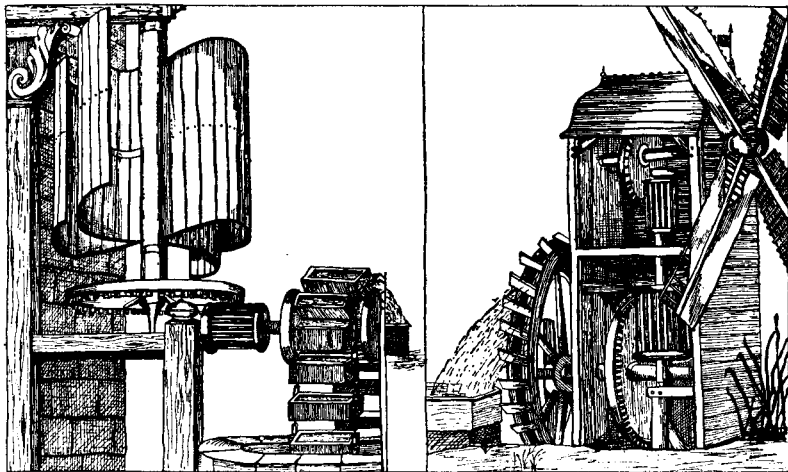
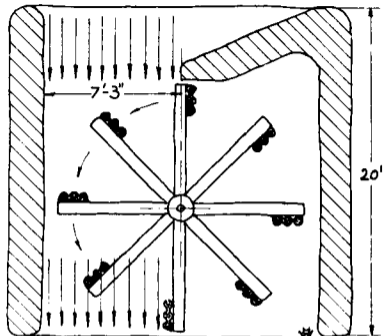
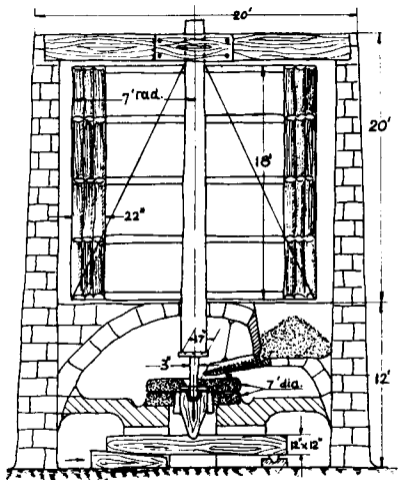

FIGURE 210—(Left) *Vertical windmill driving chain-of-buckets in a well; (right) fixed horizontal windmill driving scoop-wheel. 1652.*



Two views of a Persian vertical-axis windmill that has traditionally been used to grind grain (see grindstones at bottom left).

Traditional Crafts of Persia, book, 304 pages, Hans Wulff, 1966, \$7.95

Abbotstone Mill, Hampshire

The drawing shows the machinery of a traditional mill. The iron water wheel (right), by Hetherington and Parker of Alton, was installed in 1876 to replace an earlier wheel. The bevelled pit wheel (bottom centre) drives an iron wallower mounted at the foot of the main vertical shaft. Above the wallower can be seen the great spur wheel (centre) of timber 'compass arm' construction, supplying power to two pairs of millstones through wooden pinions, or stone nuts, mounted on iron spindles. These are supported on timber bridge trees (left, centre), centering being effected by handcrews. Near the top of the main shaft is a wooden 'clasp-arm' crown wheel, and a lay shaft (top left) from which the secondary machinery of the mill is driven by belting. Above the main shaft is the vertical ballard of the sack hoist (top centre) driven by an iron clutch and suspended from a heavy balance beam. Scale in metres.

