

let us consider the design, development and production of windmills. The windmills as produced in industrialised countries use high technology, requiring well-developed associated technologies to assist the design. Some of the complex blades used in certain windmills are actually the result of complicated computer programmes, complex materials and sophisticated presses to fashion the shapes. It would be inappropriate to introduce to a developing country a technology which is either static, or too advanced for manufacture in the country. In other words, a starting point has to be established which is compatible with technological skills available in the country at that particular time, so that as and when the country acquires high technology, a linkage can be readily created

whereby products or equipment are naturally and automatically improved through the use of that high technology. The drawings supplied in Figures 6.8 to 6.23 for the manufacture of windmills take into account that 'starting point', fully utilising available skills and technology, while leaving ample room for further development and improvement.

The windmill designated 12 PU 500 Windmill for Irrigation has been designed by Niek van de Ven for the Working Group on Development Technology (WOT), Twente University of Technology, Vrijhof 152, P.O. Box 217, 7500 AE ENSCHEDE, The Netherlands. Any technical assistance or further information needed will be gladly supplied by the Working Group on request.

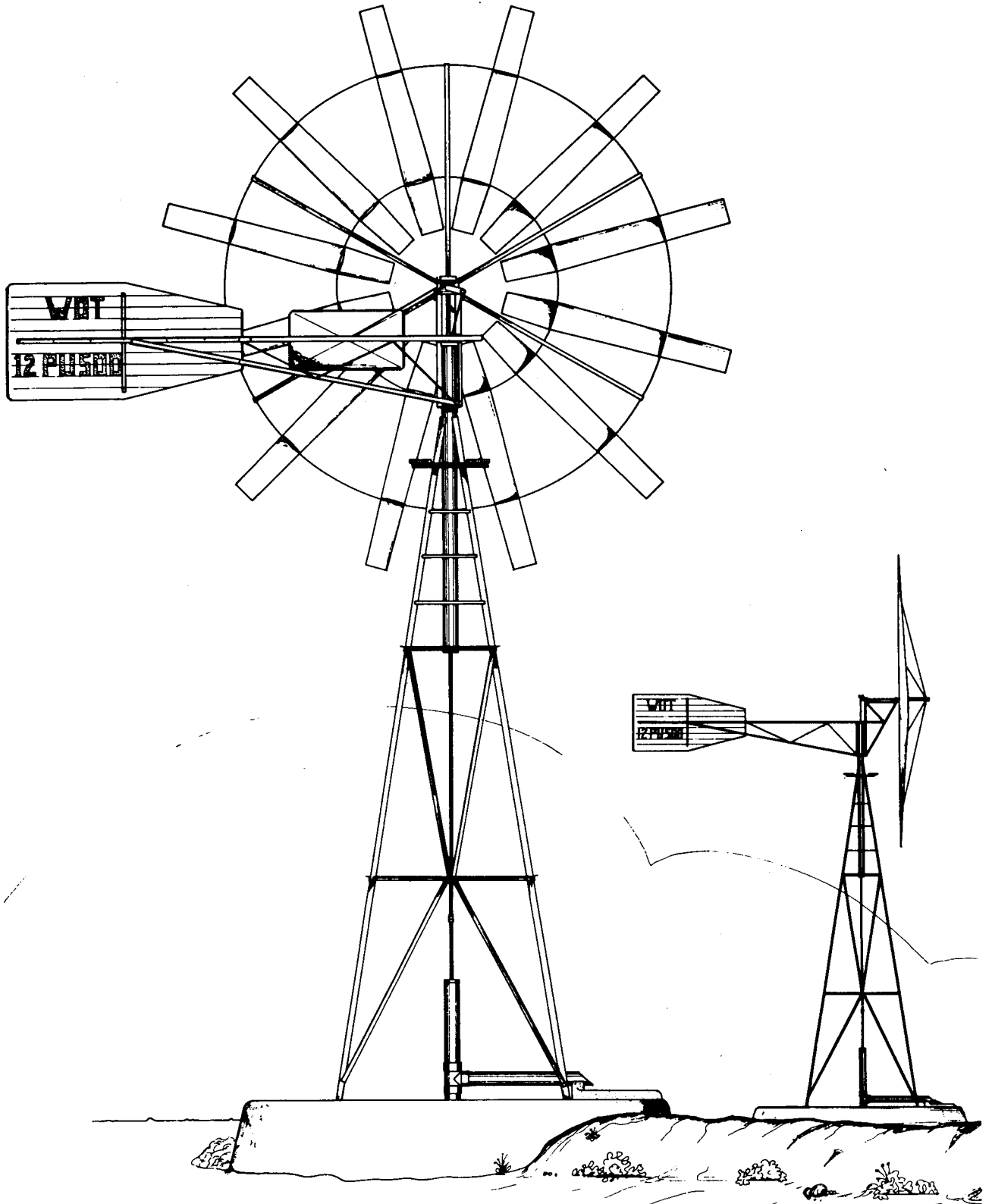

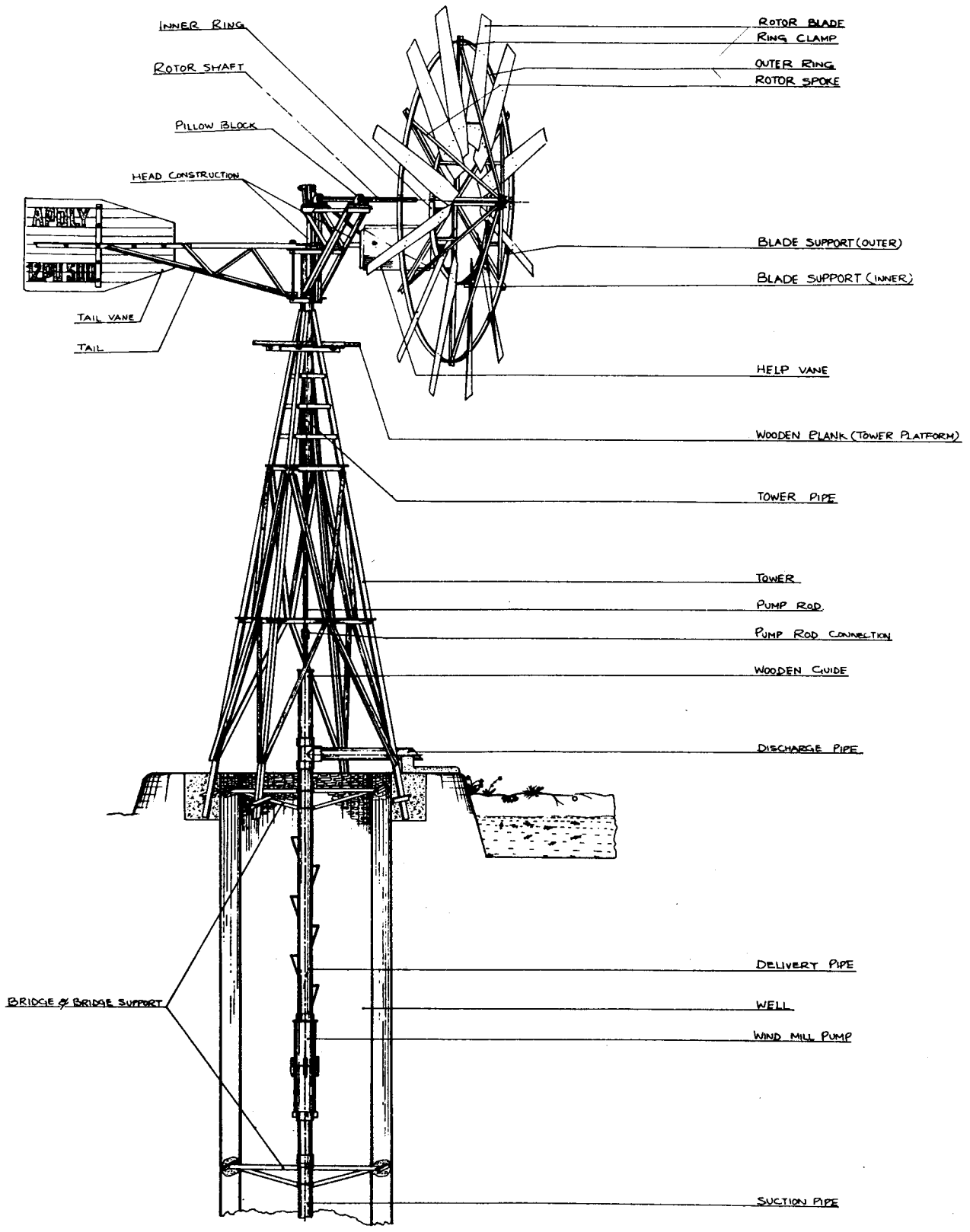
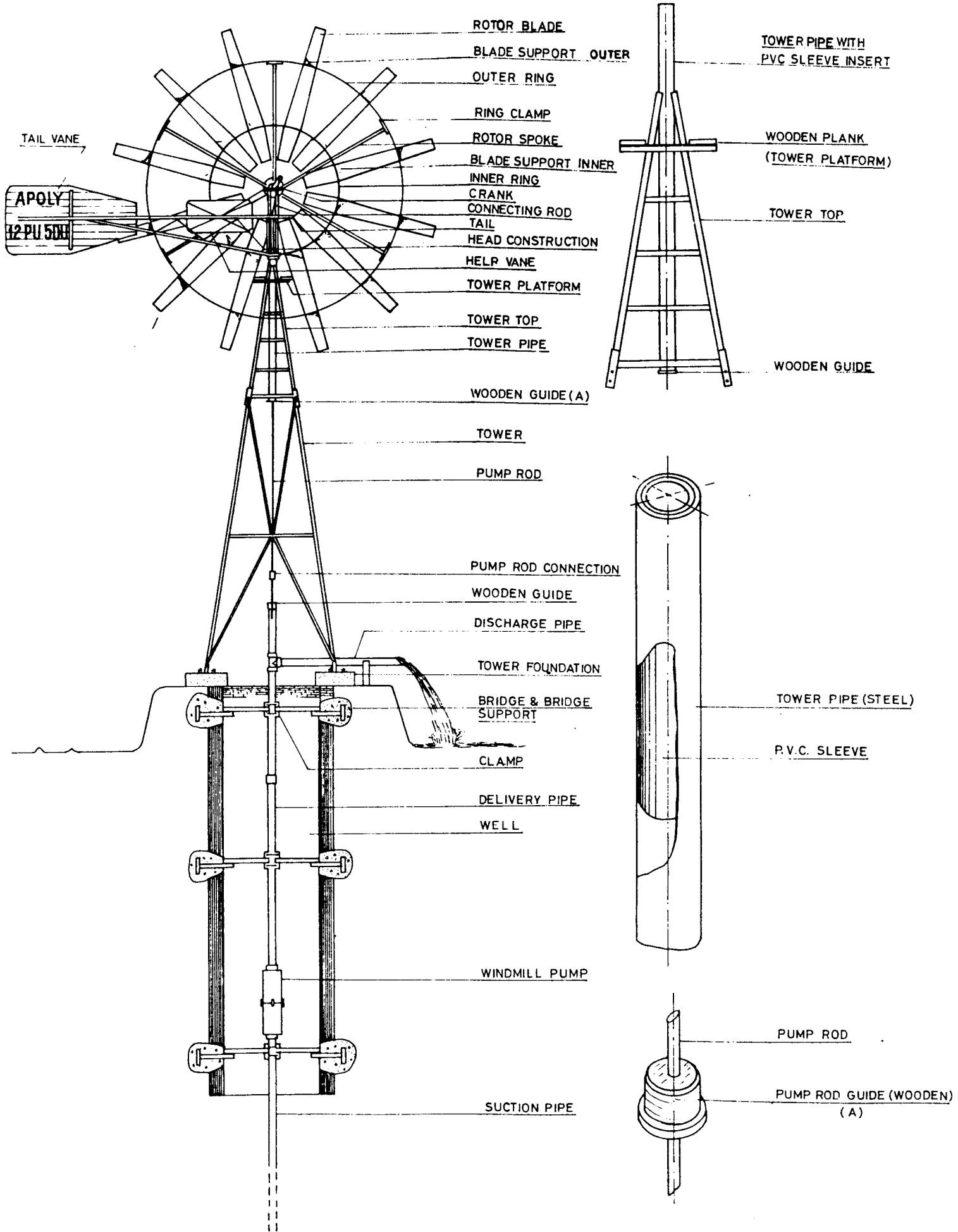
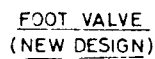
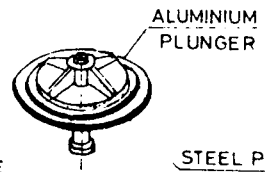
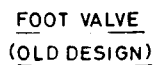
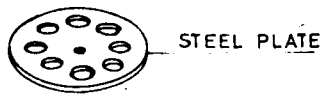
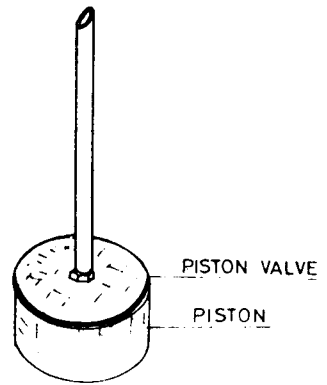
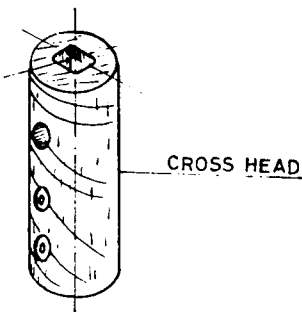
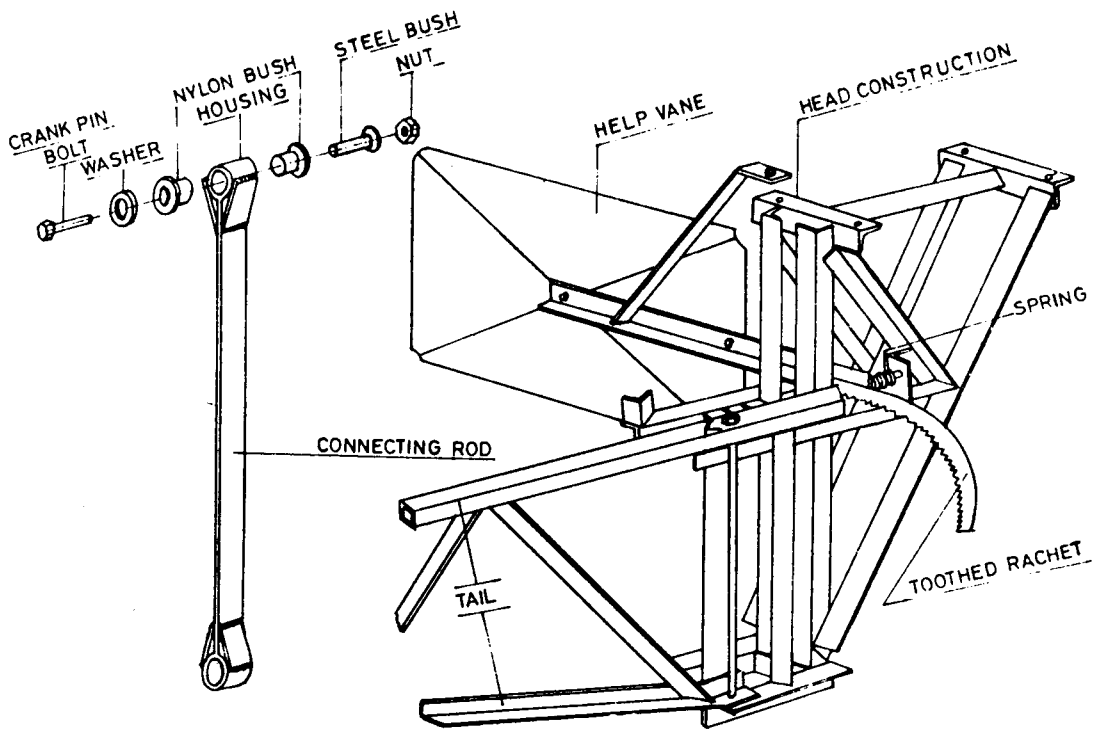

Fig. 5 12 P U 500 Water Pumping Windmill





SCHEMATIC OF
12 PU 500 WATER PUMPING WINDMILL
INSTALLATION

WIND ENERGY R & D CENTRE
INSTITUTE OF ENGG. & RURAL TECHNOLOGY

ALLAHABAD
211002

**7. Guidelines for Site Selection for
12-PU-500
Water Pumping Windmill**

GUIDELINES FOR SITE SELECTION

7.0 General

Water pumping windmills can be installed on an open well, a tube well, or near a canal, stream, pond, creek etc.

7.1 Surroundings of the Site

Taking the site as the centre there should not be any obstacle of more than 4 meter high height within an area of 100 m radius. If any such obstacle is there it should be cleared before the installation of the windmill. Alternatively, the height of the tower has to be increased suitably.

7.2 Well and Boring

- (a) If the diameter of the well is not small enough to accommodate "tower leg pitch", some modification has to be carried out in the tower design. In case the well is of a larger diameter than the tower, the legs have to be increased in length. Two legs then will be supported over a steel bridge or a girder spanning over the well and the remaining two legs will be outside the well.
- (b) The well should be in proper condition, otherwise repairs in the masonry work and cleaning of the well should be carried out before the installation.
- (c) The refilling capacity of the well should be about 25 cubic metre/hr. otherwise cleaning/boring of well has to be done. If it is a cavity boring, it should be cleaned preferably by compressor unit so as to achieve a discharge rate not less than 35 cubic metre/hr.
- (d) When the installation has to be done over a borewell, a masonry pit is prepared. The diameter of the pit may be 1.5 m, and its depth shall be the same as spring water level below the ground.
- (e) The total head over which the water is to be pumped should preferably be within 15 m and not more than 20m in any case.

7.3 Water Storage Tank

Before the construction of water storage tank near the windmill, it is necessary to test or evaluate the soil characteristics, specially its permeability. This will help in deciding whether the tank be an earthen one or lined by a suitable material.

A proforma has been designed to collect relevant site information to select a suitable installation site.

7.4 Proforma for Site Selection

1. (i) Name and address of the organisation.
.....
- (ii) Name and address of the representative of the organisation.
.....
2. Exact location of the place where the windmill is to be erected
.....
3. End use of the windmill
- (a) If drinking water supply, population to be served
.....
- (b) If minor irrigation, cultivated area in hectares with cropping pattern
.....
- (c) If brine pumping, quantity of salt water to be pumped in litres.
.....
4. Distance of the windmill site from the collaborating organisation (please mention the details of the route to the windmill site.
.....
.....
5. Surroundings of the site :
- (a) Obstacle, if any, within metre radius (taking site as centre) :
- (i) Nature of the obstacle
.....
- (ii) Distance of the obstacle from the windmill site
.....
- (iii) Height of the obstacle
.....
- (b) Whether it can be removed or not
.....
- (c) Whether it should be removed or not (considering main wind direction)
.....
.....

6. Available sources for water pumping

Open well/pond/river/sea/tube well/
canal/any other.

(a) If open well -

- (i) Inside diameter/size/depth
Please give dimensions
A,B,C,D,E and F on figure 7.
- (ii) Average depth of water
table in summer season
- (iii) Average depth of water
table in rainy season
- (iv) Refilling capacity of
well/tube well
- (v) Whether the capacity can be
increased or not

(b) If bore well -

- (i) Depth of boring
- (ii) Size of tube well
- (iii) Position of the boring at the
centre/out of centre
- (iv) Age of the boring/well
- (v) Whether the boring has been
cleaned.
- (vi) Date of boring
- Type of system used for
cleaning.
- (vii) Vertical distance between
the top of bore pipe and
the water table.
- (ix) Height of the boring pipe
above water level.
- In rainy season
- In summer season

Approximate value of soil bearing
capacity of the soil

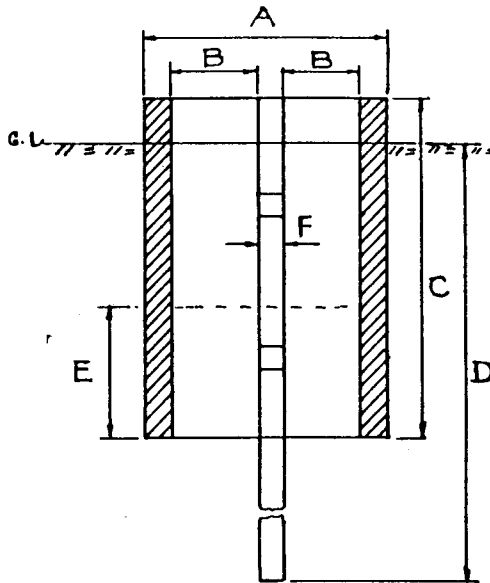

Fig.7 Dimensions of Well and boring to be measured and recorded

- 8. Approximate value of soil permeability (in view of water retention in storage tank built at the ground level)
- 9. Whether auxiliary structures are to be made in view of windmill erection like masonry pit boring in the open well, special foundation for the tower legs open wells or some odd situation
- 10. Further details, if any
- 11. Remarks

Signature of representative of organisation

Signature with seal of head of organisation.

8.0 Installation
12-PU-500
Water Pumping Windmill

INSTALLATION OF WINDMILL:

8.1 General

The following windmill parts are supposed to be prefabricated: tower, head construction, moving parts, rotor frame and blades, and the pump section. In addition to these, some more essential steps to be taken are listed here. First of all the parts are composed partly in order to check the fit. The head construction may be put on the tower to find out if it rotates smoothly over the crosshead and the connecting rod. The fit of some blades is also to be checked (at random). Until and unless these checks are confirmed the windmill is not ready for transport. Another important thing with regard to windmill installation should not be forgotten. Help devices like the jib crane and lifting hook, which are represented in the drawing, are not only helpful but are a must from the safety point of view.

The use of the jib crane is really necessary for lifting the head construction and rotor both. While fabricating the jib crane care should be taken to see that the pulling rope runs nicely in the pulley and cannot run off:

The lifting hook is a help device which provides a suitable attachment to the head construction which is situated above the point of gravity of the latter. One can imagine what happens if no lifting hook is applied: the head construction tumbles over and nobody will be able to handle it during the procedure of lifting and installing it.

8.2 Tools & tackle required during installation:

1. Spirit level	1
2. Plumb with 20 m fisher nets string	1
3. Steel tape (15 metre)	1
4. Manila rope 1½" x 30 metre long	one
5. Manila rope ¾" x 20 metre long	one
6. Mason's tool kit set	one set
7. Jib crane	1
8. Winch and wire rope 20 metres long x ½" or (chain pulley with chain 1½" size x 20 metres long)	one
9. Chain wrench (4" pipe size)	1
10. Chain wrench (4" B.S.P. pipe size)	2
11. Pipe wrench (2" pipe size)	1
12. Ball pin hammer 2 lb. with handle	1
13. Hand hacksaw with 6 spare blades	1
14. Double ended spanner set	1 set
15. Ring spanner set	1 set
16. Adjustable slide wrench 12" long	1
17. Bastered double cut flat file 12"	1
18. Round file rough 10" x 3/8" Dia.	1
19. Wood file 12"	1
20. Small grease gun	1

- | | |
|---|---|
| 21. Chisel 6" (Flat) | 1 |
| 22. Water Pump Plier | 1 |
| 23. Screw Driver 6" | 1 |
| 24. Screw driver 8" | 1 |
| 25. Centre Punch | 1 |
| 26. Hand drill with drilling capacity 1/2" Dia. | 1 |
| 27. Drill bits (Straight Shank) 1/2" | 1 |
| 28. Drill bits 3/8" Dia. | 3 |
| 29. Drill bits 5/8" Dia. with reduced shank | 1 |

* Hand tools should be of standard make such as Gedore, Taparia, Everest or equivalent.

8.3 Illustration showing the position of Tower Foundation Bolts.
(Refer. Fig. 8)

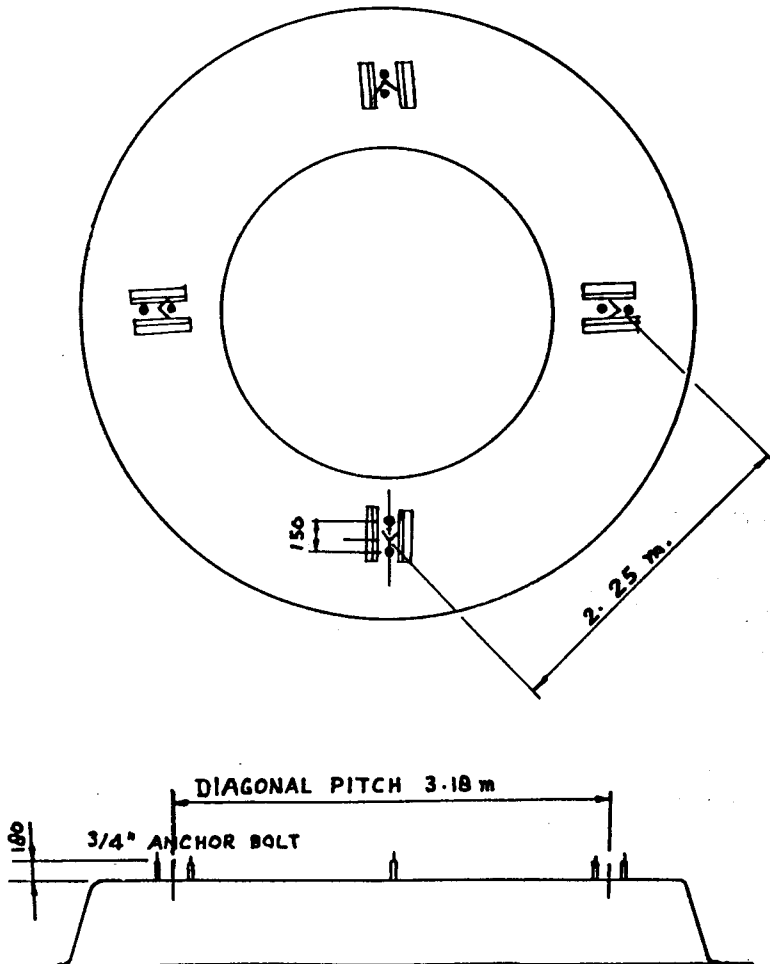

Fig. 8 Position of Tower Foundation Bolt

- 8.4 Details of Infra-structure to be prepared before the erection of the windmill.
(Refer Fig. 9, 10 & 11)
- 8.5 Details of Sub-structure and Puca alignment fixture of 12-PU-500
Water Pumping Windmill
(Refer Fig. 12)

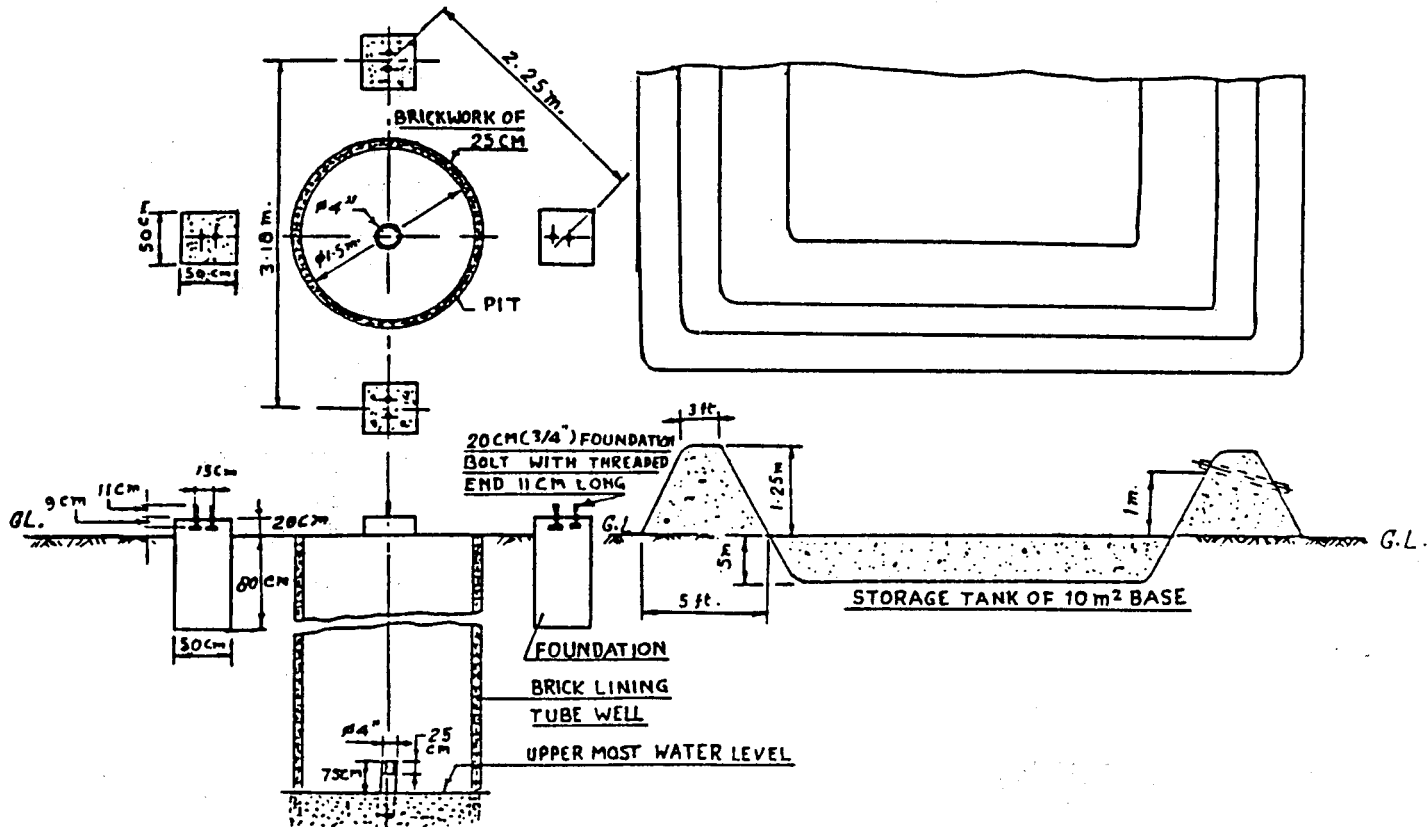

Fig. 9 Details of infrastructure to be prepared before erection of windmill

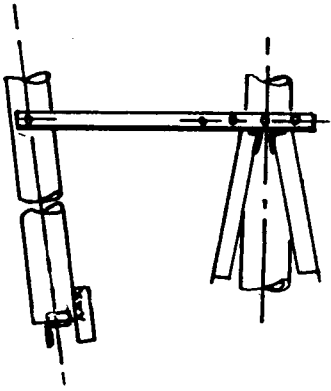

Fig. 10

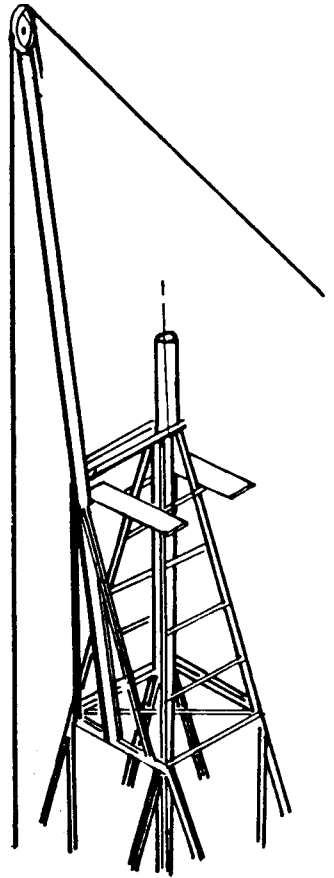
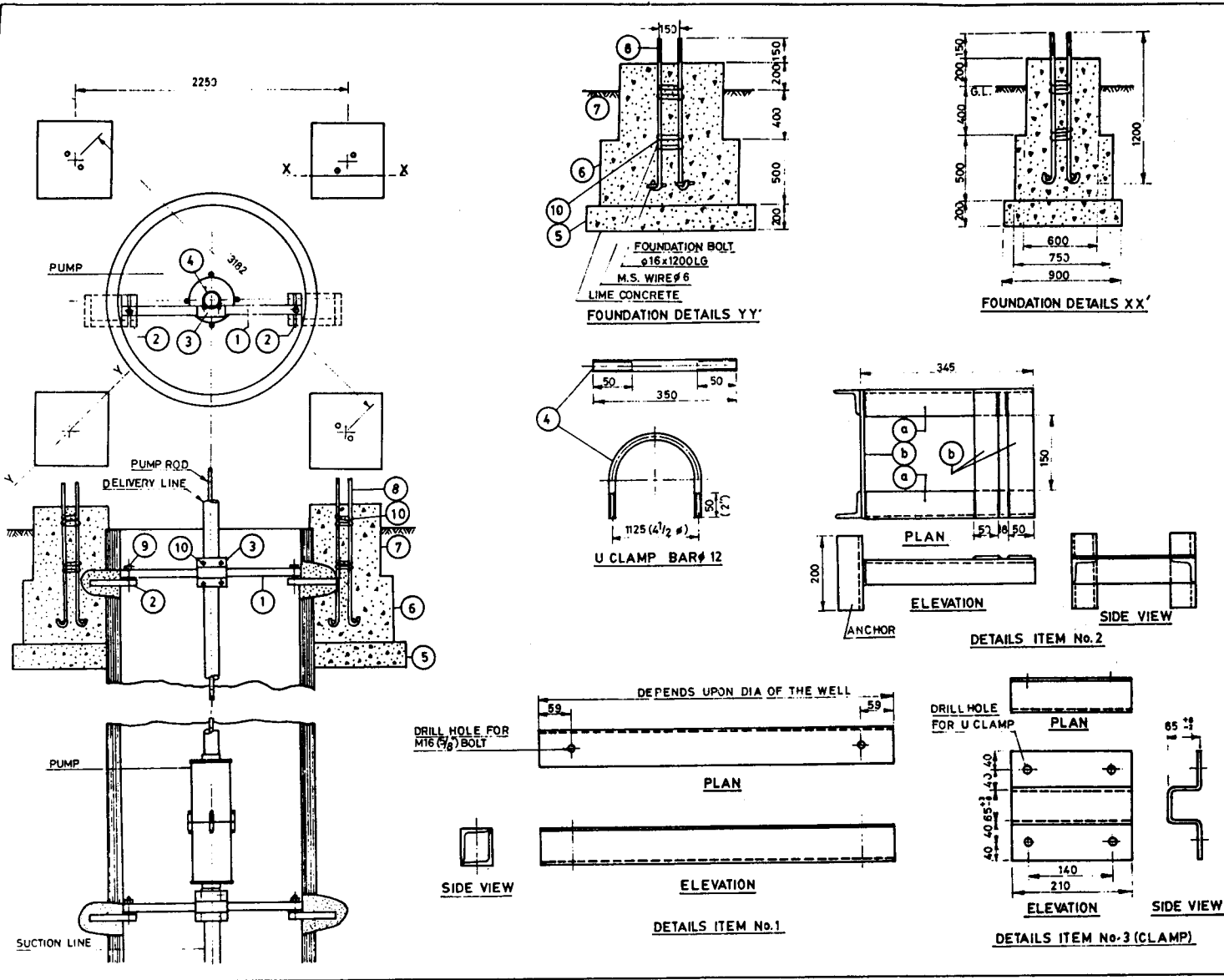

Fig. 11

Fixing of Jibcrane on the Tower



10.	WIRE	φ 8		
9.	NUT, POLT, WASHER	φ M16 x 100 (5/8" x 4)		
8.	FOUNDATION BOLT	φ 16 x 1200 LONG		
7.	SECOND STEP		M15 MIX CONCRETE 1:2:4 CEMENT FINE AGGREGATE COARSE AGGREGATE	
6.	FIRST STEP	750 x 750 x 500	DO	
5.	BOTTOM STEP	900 x 900 x 200	1:2:4 LIME CONCRETE	WELL RAMMED
4.	U CLAMP (4 No.)	BAR #12 (1/2") LENGTH 350 ± 14"	FOR φ 4" PIPE	FOR ONE TRUSS
3.	M. S. PLATE (1 No.)	THICKNESS 4 SIZE 355 x 250		FOR ONE TRUSS
2.	a M.S. ANGLE (2 No.) b M.S. PLATE (3 No.)	SIZE 50 x 50 x 6 LENGTH 345 SIZE 50 x 4 LENGTH 250		
1.	TRUSS M.S. ANGLE (2 No.)	LENGTH IN INSIDE OF WELL OR PIT SIZE 65 x 65 x 6		TRUSS DIMENSION WILL VARY WITH THE φ CONSIDER THE WELL DIA.
SL No.	ITEM	L B D H	SPECIFICATION	REMARKS
DETAILS OF SUB STRUCTURE AND PUMP ALIGNMENT FIXTURE OF 12 PU 500 WINDMILL				
FOR INFORMATION	INSTITUTE OF ENGG. & RURAL TECHNOLOGY (Near Prayag Rly. Stn.) ALLAHABAD 211002			

Fig. 12

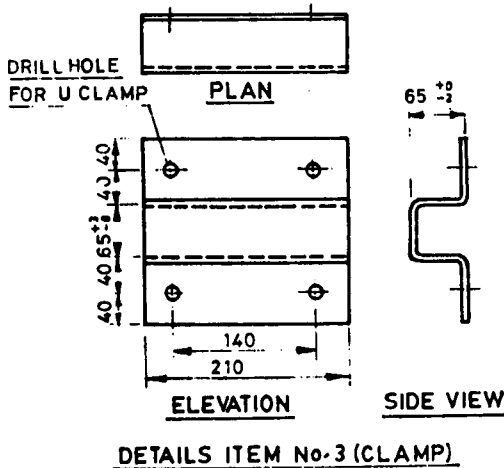
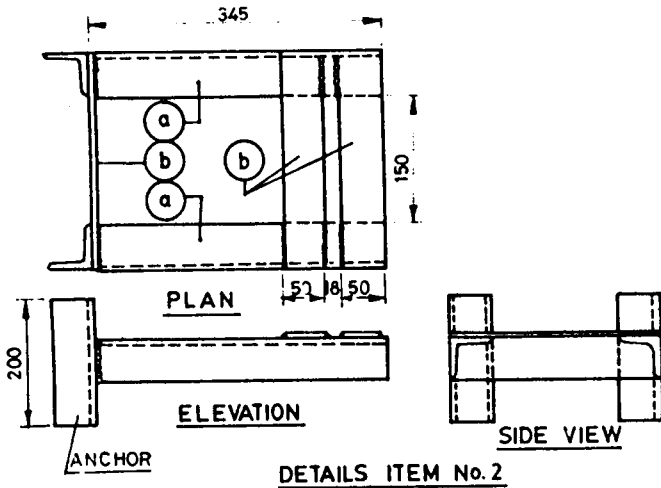
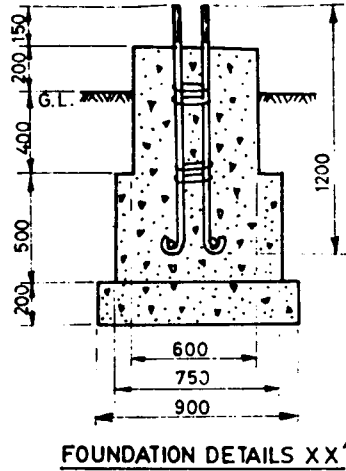

10.	WIRE	$\phi 6$		
9.	NUT, BOLT, WASHER	$\phi M16 \times 100$ (5/8" x 4")		
8.	FOUNDATION BOLT	$\phi 16 \times 1200$ LONG		
7.	SECOND STEP		M15 MIX CONCRETE 1:2:4 CEMENT FINE AGGREGATE COARSE AGGREGATE	
6.	FIRST STEP	750 x 750 x 500	DO	
5.	BOTTOM STEP	900 x 900 x 200	1:2:4 LIME CONCRETE	WELL RAMMED
4.	U CLAMP (4 No.)	BAR $\phi 12$ (1/2") LENGTH 350 = 14"	FOR $\phi 4$ " PIPE	FOR ONE TRUSS
3.	M. S. PLATE (1 No.)	THICKNESS 4 SIZE 355 x 250		FOR ONE TRUSS
2.	a M S ANGLE (2 No.)	SIZE 50 x 50 x 6 LENGTH 345		
	b M.S. PLATE (3 No.)	SIZE 50 x 4 LENGTH 250		
1.	TRUSS M.S. ANGLE (2 No.)	LENGTH IN INSIDE OF WELL OR PIT SIZE 65 x 65 x 6		TRUSS DIMENSION WILL VARY WITH THE ϕ (INSIDE OF THE WELL PIT)
SL No.	ITEM	L B D H	SPECIFICATION	REMARKS
DETAILS OF SUB STRUCTURE AND PUMP ALIGNMENT FIXTURE OF 12 PU 500 WINDMILL				
FOR INFORMATION		INSTITUTE OF ENGG. & RURAL TECH- NOLOGY (Near Prayag Rly. Stn.) ALLAHABAD 211002		

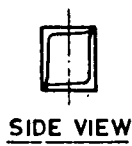
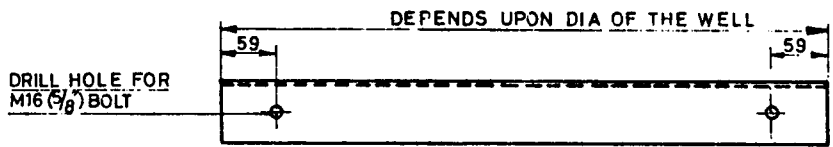
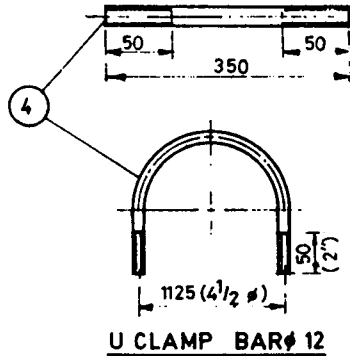
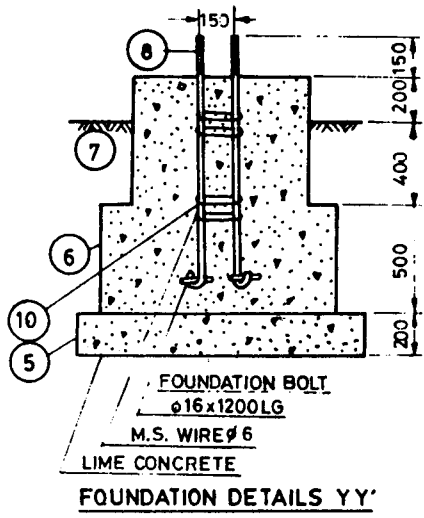

DETAILS ITEM No.1

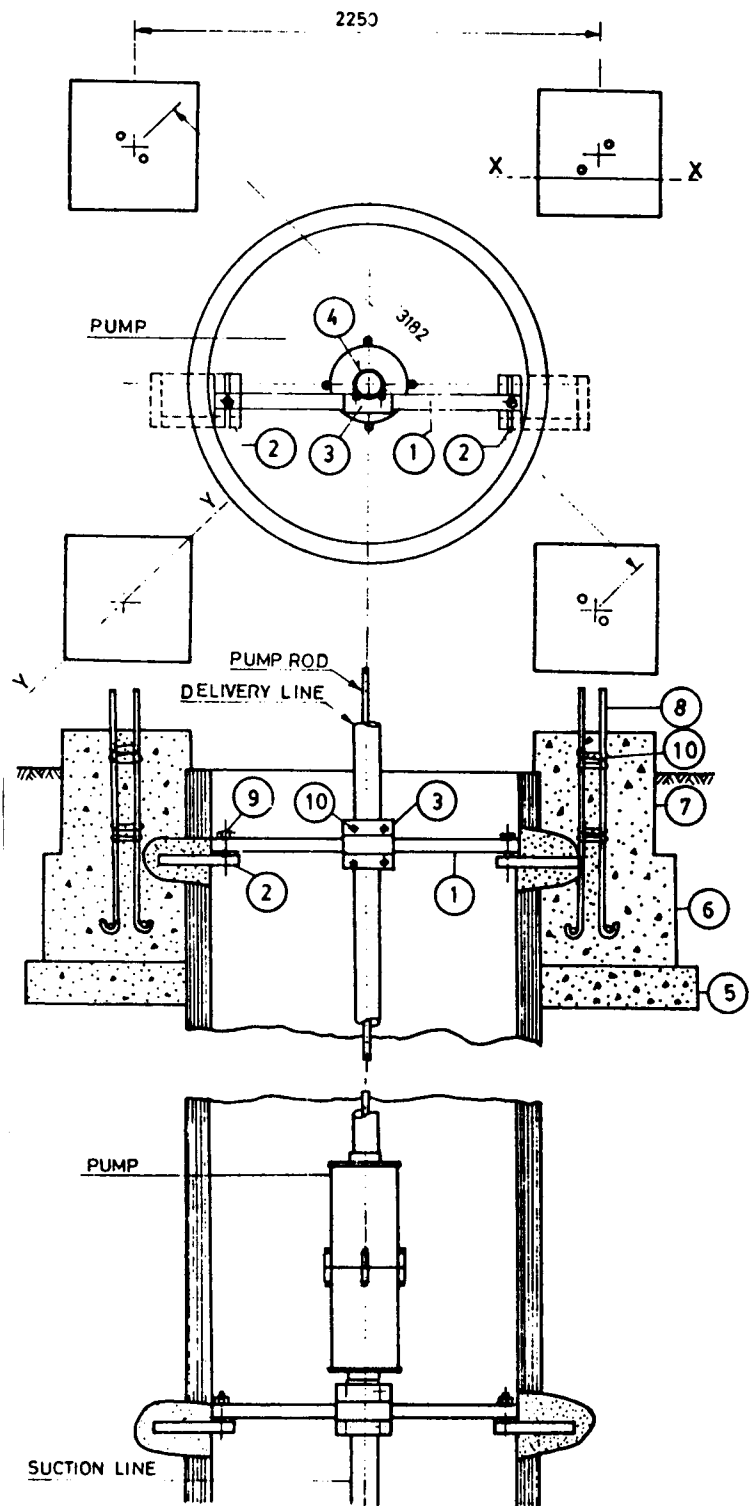

8.6 INSTALLATION OF THE TOWER

The Tower is supplied in a knocked-down state and has to be assembled. The holes for the foundation are dug at the desired pitch. They are made of equal depth and wide enough to provide sufficient space for the towerleg anchors and to enable the tower to shift to a certain extent. The tower is laid in position and a rope is connected to the top portion. A ladder (or some bamboos) are kept vertically over which the rope is laid. Before pulling the tower upright one has to be sure that the ladder (bamboos) as well as the tower itself will not fall sideways. Some extra hands can prevent this by guiding and supporting them with ropes. After the erection procedure the tower is placed vertically. This is checked by means of water level gauge which is kept beside the tower pipe (not at top of the tower pipe edge). Some filling material (e.g. bricks) are shifted under the tower leg angles temporarily during the adjustment in vertical sense. The desired position of the centre is checked by means of a rope and plumb bob with reference to the alignment of the tower with the centre of the well or the tubewell. The vertical position is checked again, and if both the positions are satisfactory the tower legs are grouted by means of cement and stone or brickchips.

The curing of the foundation needs at least 5 days, meanwhile, the time consuming fixation of the pump is carried out. For the grouting needed for pump fixation, the required mortar is made available during grouting the tower legs.

8.7 INSTALLING THE HEAD CONSTRUCTION

The jib crane is pulled and pushed up beside the tower and is finally set on angle of the tower. The jib is installed on the 'wind shadow' side of the tower (see drawing) while its two clamping angle-iron arms enclose the tower pipe on most outward position.

Now the complete head construction without the help vane is brought under the jib. The lifting hook is bolted to the tail at about 1.5 metres distance from the tail hinge. the head tends to turn towards the tail, since the lock mechanism of the help vane is kept out which makes the entire head construction difficult to handle. A locking device is arranged temporarily either by roping the upper tail-beam to the head construction or by putting a clamp overthere. A pin stuck through the head and ending up in the upper tail-beam may also serve the purpose very well.

The rope is connected to the lifting hook and 'balancing' of the head construction is tried out in such a way that the front part of the head is out of balance; (say: 5 degrees). This is essential to ensure that the framing of the head construction, which is going to surround the tower pipe, will grip and throttle it. (This is a most essential precaution which seems to be even contradictional).

The head is now lifted slowly by pulling the rope (by about 6-persons) and two persons guide the head while climbing the tower. The head is allowed to seek its position in the wind (do not force it and lift it till it floats just above the tower pipe). The two persons, each standing on the platform now, guide the bottom part of the head just over the tower pipe. The head is lowered down very slowly and the persons keep the head pressed down over the tower pipe. Actually they should maintain the '5 degrees out of balance' state of the head while the head itself is lowered down stepwise. The last few centimetres may be difficult as the inside angles of the head might touch the tower pipe edge and so obstruct a further sliding over of the head. If extra attention is paid to a proper centering, no problems appear and the head sinks into its final position. Loosen the rope and remove the lifting hook, and preparations are undertaken now to install the rotor frame.

8.8 INSTALLING THE ROTOR

First of all the position of the jib crane is adjusted. The jib crane is put in the most upright position, and the head construction is turned 180 degrees so that the front part of the head is touching the jib crane. For security reasons a rope connection is made overthere so that the head on which the rotor, shaft and bearing blocks are going to be placed, remains under the pulley of the jib crane. This is necessary as appearing wind might turn the head construction.

Both the rotor halves are connected now and the shaft is slid into the hub to take its normal position. The hub bolts are tightened stepwise as well as the securing clamping angle iron, care-

fully the rotor frame is lifted and carried to the tower where it is put in vertical position, standing on one of its six spokes. Now it sets against the tower, right under the jib crane. Care should be taken of the extending shaft pointing into to lattice of the tower construction, as this may cause problems.

The rope is lowered down now from the jib crane and it is connected to the hub of the rotor frame, so that the rope passes both the inside and outside ring from the back of the rotor.

Carefully and slowly the rotor is lifted and two persons guide it while climbing the tower. Extra attention is paid to the extending shaft which tends to get stuck in the lattice of the tower. Finally, reaching the level of the platform it is seen that the shaft is positioned on the correct side of the jib crane, since the latter itself will be an obstacle.

The entire rotor and shaft are hovering above the head now. With some effort the bearing blocks are positioned above their supports and the rotor is lowered down very slowly. The bolts are put quickly and the nuts are screwed on by hand first. The position is secured now and the rope is removed from the rotor and jib crane and the latter is lowered down. The rotor is revolved through a few revolutions in order to enable the bearing blocks to settle on their supports. The bolts of these bearing blocks are tightened.

The windmill is put in a secured position and the mounting of the blades can start now. One person sits on the platform and the other stands on angle 6 of the tower. The bolts, nuts and the tools can be kept conveniently in a basket which is hung temporarily from the platform during this bolting activity. It is necessary that the blades are mounted in crosswise sequence e.g. 1-7, 8-2, 3-9, 10-4 etc.

After this the crosshead, assembled with connecting rod and the pump rod both, is pushed into the tower pipe and the crank bush and central bolt are assembled. It is to be seen that the locking bolt of the PVC tower pipe insert is removed temporarily in order to allow the crosshead to pass in. Also important is to install the crank bush with its collar facing the crank plane and the application of the washer in between the bolt head and the bush edge is to be removed. The bolt is tightened up strongly and the locking screw for the PVC tower pipe insert is re-installed. The wooden pump rod guide is fitted on the bottom side of the tower pipe and locked with the bolt.

Now the help vane arrangement is assembled and the windmill can be put to face the wind.

8.9 INSTALLING THE PUMP

It is preferable to have the pump section installed and completed by the time the windmill itself has been assembled.

As expressed earlier the installation of this very essential part should not be underrated as many difficulties are felt with regard to the alignment and fixation in the well. The reciprocating forces, which act on this section, can be considerable and a minor play in the suspension, either in axial or in radial sense, can lead to a "noisy dancing and swinging" performance of the pump. In the long run the grouted parts of the suspension will come out, the nuts and bolts will run loose and hammer their way through their counterparts.

A good deal of attention, therefore, is to be paid to the proper alignment and strong fixation of the pump and delivery pipe in order to prevent the above mentioned malfunctioning.

Though the wells for windmill sites differ in depth of water table, diameter and structure, at least some general guidance can be given to obtain suitable suspension :

In case of centrally situated installation of the windmill above the well it is advisable to fix at least one "bridge construction". This structure lends the needed suspension, provided of course, that its legs are grouted thoroughly in the well casing.

Centralisation at the bottom part of the pump section is provided by the tube well (if applied) or by the application of a similar "bridge construction" which embraces the suction pipe on which the pump has been screwed.

In the latter case grouting of the bridge into the well casing might be complicated since the bottom part of the pump is situated preferably under the water table in order to make the pump

self priming and to assure the desired minimum suction head. The problem is overcome either by grouting the bridge legs during a period for which the lowest water level exists (dry season, after excessive water removal by another pumping device) or by using an expanding clamp mechanism in the bridge legs themselves. This can be obtained by applying at each leg a bolt/nut combination in such a way that by screwing out the bolt the expanding effect occurs.

In case of an off-centre installation of the windmill not much choice is left and clamps, equipped with strong anchors which are grouted into the well casing, prove to be the best solution.

As far as the fixation under the waterline is concerned (in case of no tube well) it is advisable to apply a connection in the well casing based on key-wedge principle.

IMPORTANT NOTE

After the completion of the erection the installation should be checked with reference to the check list, and a record of all readings taken, be maintained.

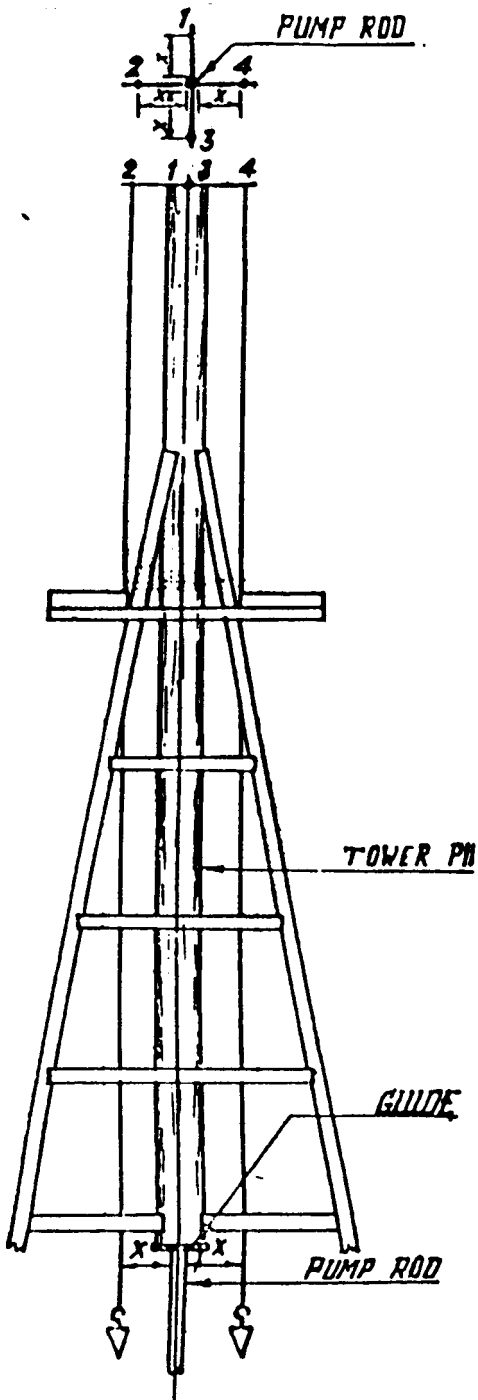

8.10 Check List for Installation of Windmill

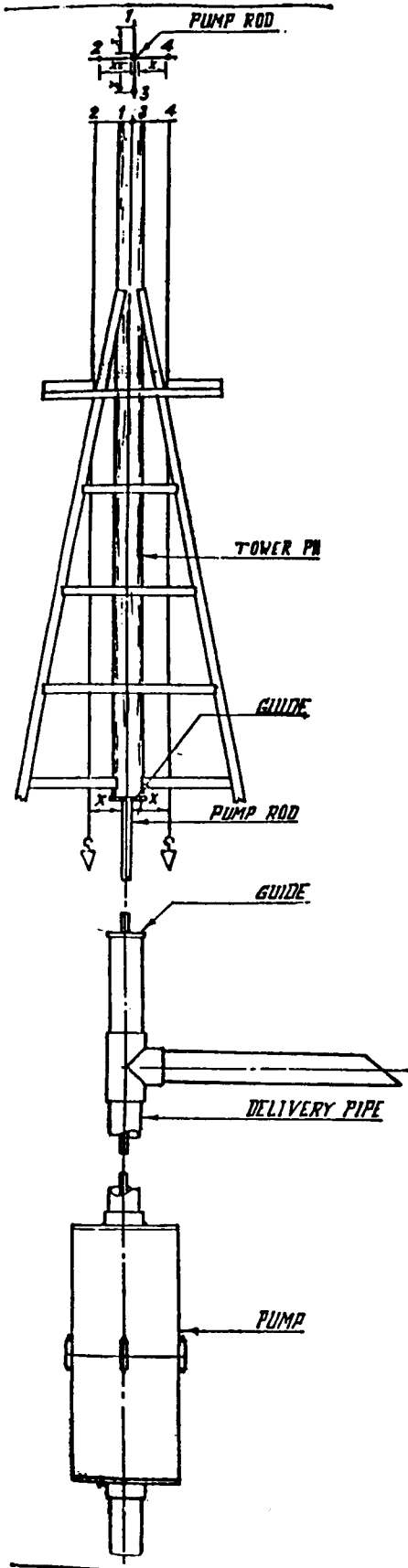

CHECKS IN WINDMILL INSTALLATION

पवन चक्की स्थापना के समय निरीक्षण

(A) Verticality (Sahul, Scale Try-square, Spirit Level)

(अ) सम्बन्धित निरीक्षण (साहुल, स्केल, गुनिया, स्प्रिट लेवल)

(a) Tower pipe (Take 4 readings)

(ए) टावरपाईप (चार रीडिंग लीजिए)

(b) Pump rod with reference to lower pipe (about 150 mm below the upper wooden guide)

(ब) टावर पाईप के सापेक्ष पम्प राड का निरीक्षण (टावर पाईप से गाइड १५० मि० मी० नीचे)

(c) Perpendicularity of tower top Face with reference to the side of the pipe.

If the distance between the two wooden guides is more than 3 metres then.

(३) टावर टॉप सतह की सम्बन्धिता पाईप के चारों ओर के सापेक्ष।

अगर पम्प राड की सम्झाई दोनों गाइड के मध्य तीन मीटर से अधिक हो तब।

(d) Measure perpendicularity of pump rod at a distance of about 150 mm above the lower guide.

(द) पम्पराड की सम्बन्धिता निचली गाईड से १५० मि० मी० ऊपर निरीक्षण कीजिए।

(e) Measure verticality of delivery pipe.

(इ) डिलीवरी पाईप सम्बन्धिता का निरीक्षण कीजिए।

1	2	3	4

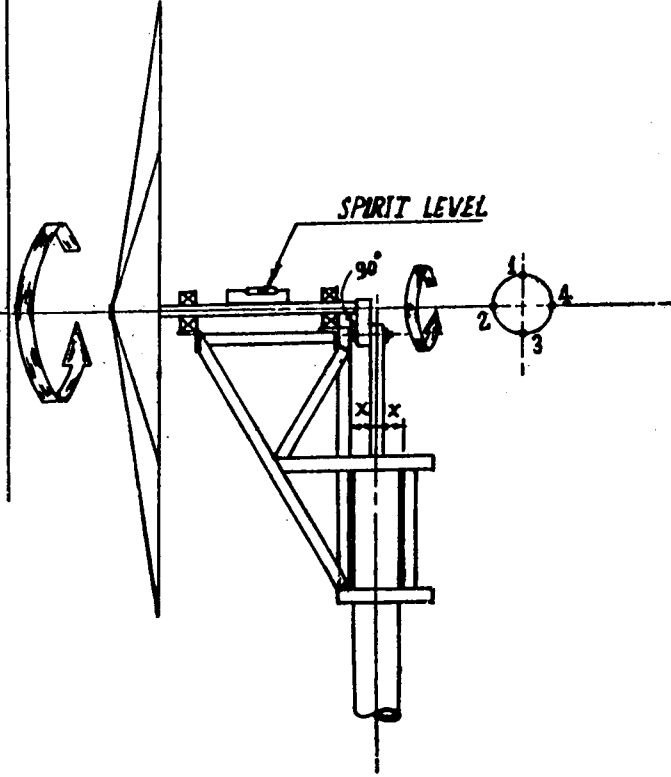

(B) SHAFT (Spirit level & Scale)

(ब) साफ्ट (स्प्रिट लेवल और स्केल)

(a) Turn the rotor around tower axis, measure level in rotor facing North, West, South & East (NWSE) w. e. at 4 positions.

(१) टावर के अक्ष के चारों तरफ रोटर घुमाइये एवं सतह का निरीक्षण कीजिए । (दूरब, पश्चिम, उत्तर, दक्षिण) चारों स्थितियों में ।

(b) Rotate rotor around the axis of the shaft and measure perpendicularity of the crank with reference to the shaft. (Measure distance between the connecting rod and head construction X).

(२) साफ्ट के अक्ष के चारों ओर रोटर को घुमाइये और क्रेक की लम्बवता जात कीजिए ।

(c) Measure clearance between the head construction & tovertop pipe surface.

(३) (हेड कन्स्ट्रक्शन एवं कनेक्टिंग राड के बीच की दूरी नापिये)

Position
स्थिति

Reading
प्रेक्षण

1.	mm मि० मी०
2.	mm मि० मी०
3.	mm मि० मी०
4.	mm मि० मी०

I II

1.	mm मि० मी०
2.	mm मि० मी०
3.	mm मि० मी०
4.	mm मि० मी०

gauge / mm
गेज / मि० मी०

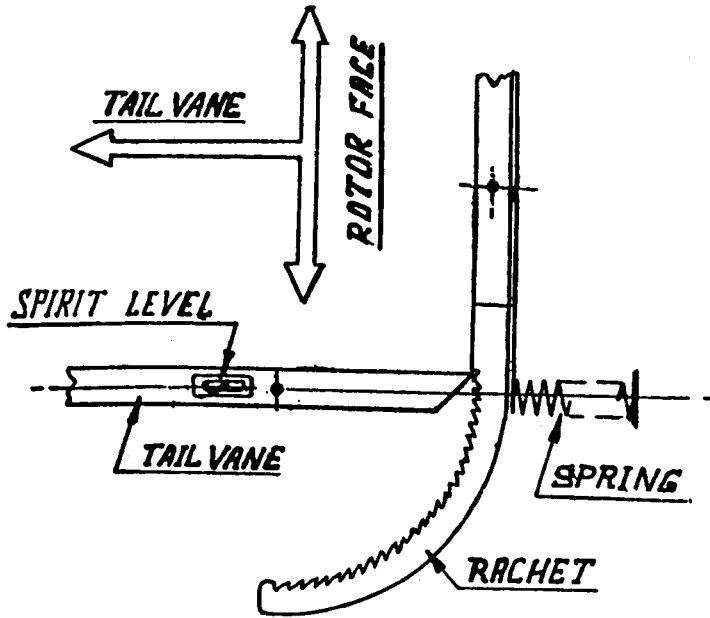

(B) Measure spring tension of the tail with the help of spring balance.

..... kg.

(१) स्प्रिंग बैलेंस की सहायता से टेल स्प्रिंग का तनाव ज्ञात कीजिए ।

(C) (a) Check meshing of the tail with toothed sector.
 (b) Measure horizontality of the tail with the help of spirit level & scale.

... .. mm.

(२) टुपेड रचेट भाग का टेल के साथ मैचिंग का निरीक्षण कीजिए ।
 टेल की क्षैतिजता स्प्रिट लेबल एवं स्केल की सहायता से ज्ञात कीजिए ।

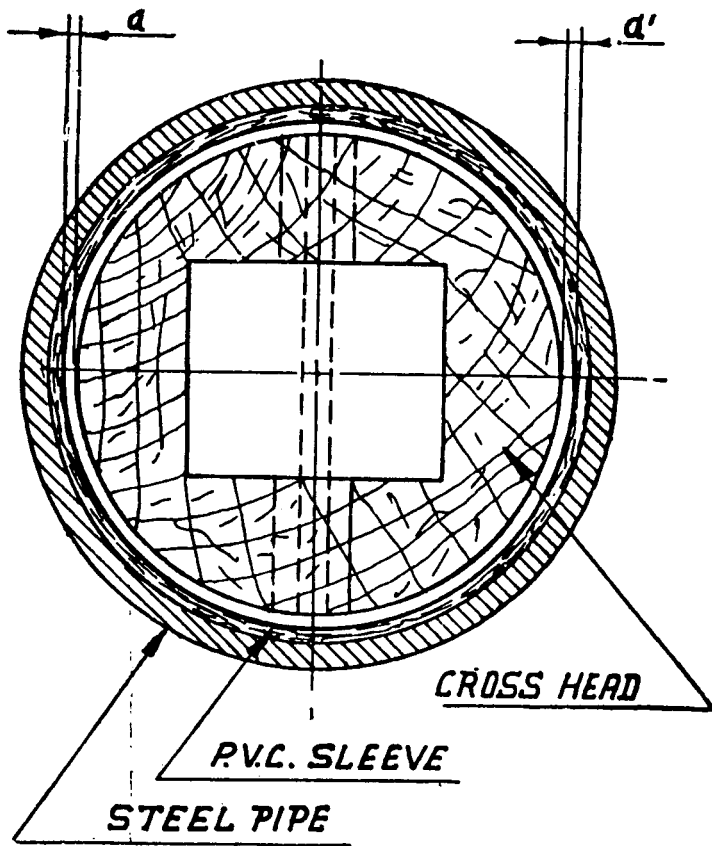

(E) Measure clearance $d \times d$ between the PVC sleeve & cross head.

..... gauge/mm.

(१) पी० वी० सी० स्लीव एवं क्रॉसहेड के बीच अन्तराल डी एवं डी, नापिए ।

गेज/मि० मी०

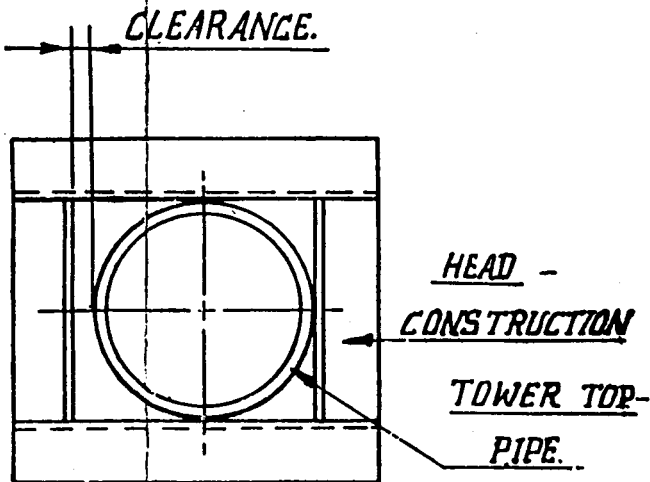

(D) Measure clearance between the head construction & tower top pipe surface.

..... gauge/mm.

(१) हेड कन्स्ट्रक्शन एवं टावर टॉप पाइप सतह के बीच अन्तराल ज्ञात कीजिए ।

गेज/मि० मी०

9. MAINTENANCE OF THE WINDMILL

Though the number of moving parts in the windmill is limited yet certain regular checkups and lubrication services should be undertaken from time to time. Also, in the long run some moving parts might wear out and need replacement. Fortunately, in this design, such parts are cheap in the material costs. They can be made easily and replaced.

9.1 THE OVERALL STRUCTURE

Actually corrosion of the steel structure is the greatest enemy of the windmill. If the corrosion problem is tackled in the right way the technical lifetime of the windmill is expected to reach at least 15 years and probably far beyond this figure.

It is advisable, therefore, to have the structure painted thoroughly with one coat of primer and two coats of finish, after chipping off the weldings. The need for these preventive measures is more in areas where the air is humid or saline as along a coast-line. The best anticorrosive zinc-based paints should be applied.

9.2 TOWER

Generally it is expected that the tower will not need any specific attention with regard to wear and tear, since it is a static structure. One should realise however, that the tower pipe serves multiple functions:-

- o It carries head construction the edge (this is in axial sense).
- o Its outside provides support to the head construction by enclosing it at the top and bottom parts (in radial sense).
- o Its inside provides the guidance to the crosshead via the contact of PVC insert.

The 'steel to steel' contact of tower pipe and head construction needs some lubrication (grease) from time to time. As long as the grease is present no excessive wear is going to occur there. Also, as long as the PVC insert remains locked in the tower pipe, the insert will serve its purpose well.

However, corrosion of the tower has to be taken into account and check-ups should be undertaken at half yearly intervals.

9.3 HEAD CONSTRUCTION

Besides its contact with the tower pipe only a few moving parts of this structure need attention for maintenance. It should be ensured that the locks of the security device remain free of any play. The functioning of the hinges of the help vane and tail vane both should be checked up from time to time since they have the tendency either to run loose or to corrode: The former will lead to loose and noisy, and hence clumsy joints, and the latter to a struggling and faltering functioning of the mechanism. The best remedy is to apply a few oil drops from time to time.

If, the help vane lock or the final lock is worn out. It would be better to take it out, apply some welding and reshape it by filing, and get it re-installed properly. There is no need to explain the necessity of a proper functioning of storm security device.

9.4 MOVING PARTS

It is assumed that the main bearings have been positioned and tightened properly. Generally the lubrication is sufficient for millions of revolutions and as long as no dust particles enter the "grease" no complications are expected. However, in course of time the grease is "rolled out" of the bearing and will change its lubricating properties. This takes years, though, to happen, but moment it is noticed, new grease (not oil) should be applied. If no grease nipple is there, the bearing housing has to be opened to apply fresh grease.

Generally the nylon (or bronze) bearings of the connecting rod keep their lubricant well. Some fresh oil drops from time to time will serve the purpose satisfactorily. The same counts for the wooden cross-head and pump rod guides. Properly soaked in oil they contain the lubricant themselves and from safety point of view it is best to keep them in that condition. Generally a "generous filling up" of the square hole in top of the crosshead with oil, provides the best guarantee that these essential wooden parts will maintain their functioning. The appearance of play in these parts after some time of functioning might seem to be bothersome, but they have a long way to go before replacement is really necessary. In short, the wear is acceptable as long as no noisy and clumsy malfunctioning occurs. The replacement is cheap and easy to carry out specially, as far as the wooden pump rod guides are concerned. With regard to replacement of the crosshead it is advisable to drill complete new holes for the pump rod crosshead connection. It will be evident that in case of replacement of worn out crosshead the replacement of the PVC insert is also recommended.

9.5 THE ROTOR

Besides maintenance concerning corrosion, the rotor does not need any maintenance. However, in some cases bolts and nuts become loose due to the alternating character of the load on them. A "cracky" noise indicates such fault.

The remedy is to check-up all bolt and nut connections, especially at the start. In a fair number of cases some fatigue cracks appear either in the outside blade supports (shearing fatigue) and/or in the blades somewhere at their edge. If it happens, supports and/or blades should be replaced by new ones.

9.6 THE PISTON PUMP

In the windmill the pump section remains the most bothersome part. Besides the checks of its suspension, checks are to be made with regard to its delivery. Depending on the purity of the lifted water the piston wears out sooner or later, resulting in a poor delivery. It should be replaced then.

If time has come to change the piston, it is better to replace the valves too. This will ensure that the newly overhauled pump will serve its purpose for the next period of time without any failure. The span of this time will depend on the purity of the water which is pumped from the source. Presence of sand particles play a significant role in the life of the piston and precautions should be taken. In case of water delivery from a tube well, a proper "washing" procedure is necessary.

Maintenance checks as given in the following pages should be carried out at half yearly intervals.

**9.7 Preventive Maintenance Schedule
Water Pumping Windmill
12-PU-500**

Sl. No.	Major Parts	Sub Components	Insepction Schedule				Suggested Remedial measures.
			D	M	Q	Y	
1.	Rotor	Hub bolts			✓		If loose, tighten
		Hub clamp bolt			✓		-do-
		All the Rotor Fasteners			✓		-do-
		Upper and lower tips of the blades	✓				If bent, remove the blades with bent tips, straighten and fix again, If badly damaged, replace it.
		Condition of paint				✓	Retouch/Repaint
		Blade supports			✓		If cracked, replace
		Inner and outer rings			✓		Repair/Replace
2.	Head Construction Tail and the security mechanism	Blades	✓				If damaged badly, replace.
		All the fasteners and joints			✓		If loose, tighten
		Condition of security lock in both secured and operational positions.			✓		If functioning is improper and it suffers from vibration check the ratchet arm and spring and the locking edge of the tail, replace the worn out part.
		Movement of head construction around the tower pipe.		✓		If the rotation around the tower pipe is not smooth, lubricate with grease. if the clearance between the tower pipe and head construction is abnormal put a shim in the gap.	

Sl. No.	Major Parts	Sub Components	Inseption Schedule				Suggested Remedial measures.
			D	M	Q	Y	
3.	Mechanical Power Transmission system.	Condition of the bearing block		✓			If cracked replace the complete bearing with housing immediately.
		Condition of the bearing for any unusual sound axial movement or play.		✓			If running dry, lubricate, if sound still persist or there is axial movement or play then replace the complete bearing.
		Bearing fixing bolts.		✓			If loose, tighten firmly.
		Rear bearing safety bracket		✓			If loose, tighten firmly.
		Hub screw of bearing		✓			If loose, tighten firmly.
		Condition of crank holes		✓			If holes are enlarged, remove the shaft with crank repair by welding and drilling repairing and reinstall properly.
		Welding joint of the crank with main shaft.		✓			If cracked or deformed remove the shaft with the crank, repair and refix properly.
		Crank bolt		✓			If loose tighten firmly.
		Collar Bush				✓	If sign of wear appears change and lubricate with grease.
		Connecting rod		✓			If broken, bent or crack appears on any joint, replace.
		Nylon bushes at both ends of connecting rod				✓	If play has developed or bushes have worn out replace them.
		Crosshead				✓	If unusual sound or play appears, replace.
		PVC Sleeve				✓	If worn out replace.
Pump rod joints				✓	If loose, tighten firmly.		
Wooden/Polypropelene guides				✓	If wornout, replace.		

Sl. No.	Major Parts	Sub Components	Insepction Schedule				Suggested Remedial measures.
			D	M	Q	Y	
4.	Piston Pump	Pipe line joints	✓				If there is any leakage check the flange and socket joints, repair.
		Coupling bolts			✓		If there is any leakage from middle section through the rubber gasket, replace the gasket, open the pump and check.
		Abnormal noise from the pump	✓				The complete assembly consisting of the piston rod, nut, brass guide, foot valve, piston barrel, replace the faulty component.
5.	Tower	All the fasteners of joints		✓			If loose, tighten firmly.
		Condition of tower pipe				✓	If bent change the tower top.
		Welded joint of tower pipe with stand legs.				✓	If cracked remove the tower top, repair and reinstall.
		Condition of protective coating.				✓	If peeled off, carry out touching with primer and paint.
6.	Foundation and Aux. Structure	Physical insp. of work	✓				If any vibrations have caused cracks, stop the windmill and repair the civil constructions.
		Supporting bridges & clamps		✓			If the clamps are loose tighten them.
		Delivery pipe bracket		✓			If fitting is disturbed, fix it correctly.

D = Daily; M = Monthly; Q = Quarterly; Y = Yearly

9.8 PART LIST OF 12-PU-500 WINDMILL

TOWER :

Sl.No.	Item	Material	Size mm	Measurements mm	No. Regd.
T/1	ANGLE IRON	M.S.	35x35x5	250	8
T/2	ANGLE IRON	M.S.	40x40x5	4500	4
T/3	ANGLE IRON	M.S.	35x35x5	1940	16
T/4	ANGLE IRON	M.S.	35x35x5	1400	4
T/5	ANGLE IRON	M.S.	50x50x6	250	4
T/6	ANGLE IRON	M.S.	35x35x5	700	4
T/7	ANGLE IRON	M.S.	40x40x5	2000	4
T/8	ANGLE IRON	M.S.	35x35x5	660	2
T/9	FLAT IRON	M.S.	32x6	580	2
T/10	FLAT IRON	M.S.	32x6	460	2
T/11	FLAT IRON	M.S.	32x6	340	2
T/12	WOODEN PLANK	WOOD	30x200	700	2
T/13	PIPE (SLEEVE)	PVC	4" BORE	710	1
T/14	TOWER PIPE	M.S.	4" N.B.	2650	1
T/15	FLAT	M.S.	32x6	410	4
T/16	PLATE	M.S.	170x160x6		4
T/17	NUT,BOLT,WASHERS	M.S.	M12x40(W $\frac{1}{2}$ "x1 $\frac{1}{2}$ "')		52
T/18	MACHINE SCREW		$\frac{1}{2}$ " ϕ x 2" long		4
T/19	MACHINE SCREW		$\frac{1}{2}$ " ϕ x 1" long		4

HEAD CONSTRUCTION :

01/15/2017

Sl.No.	Item	Material	Size mm	Measurement mm	No. Regd.
HC/1	ANGLE IRON	M.S.	40x40x5	200	1
HC/2	ANGLE IRON	M.S.	40x40x5	200	1
HC/3	ANGLE IRON	M.S.	40x40x5	155.5	4
HC/4	ANGLE IRON	M.S.	40x40x5	555	2
HC/5	ANGLE IRON	M.S.	40x40x5	590	1
HC/6	ANGLE IRON	M.S.	40x40x5	1000	2
HC/7	ANGLE IRON	M.S.	40x40x5	1110	2
HC/8	ANGLE IRON	M.S.	40x40x5	540	2
HC/9	ANGLE IRON	M.S.	40x40x5	460	2
HC/10	ANGLE IRON	M.S.	40x40x5	500	1
HC/11	ANGLE IRON	M.S.	65x65x6	250	2
HC/12	ANGLE IRON	M.S.	40x40x5	1500	1
HC/13	ANGLE IRON	M.S.	40x40x5	4000	1
HC/14	ANGLE IRON	M.S.	40x40x5	3000	1
HC/15	ANGLE IRON	M.S.	40x40x5	125	1
HC/16	ANGLE IRON	M.S.	40x40x5	60	1
HC/17	ANGLE IRON	M.S.	40x40x5	45	1
HC/18	ANGLE IRON	M.S.	40x40x5	1000	1
HC/19	FLAT IRON	M.S.	32x6	115.3	2
HC/20	FLAT IRON	M.S.	32x6	65	2
HC/21	FLAT IRON	M.S.	32x6	150	1
HC/22	FLAT IRON	M.S.	32x6	115.5	1
HC/23	FLAT IRON	M.S.	32x6	830	1
HC/24	FLAT IRON	M.S.	32x6	750	3
HC/25	FLAT IRON	M.S.	32x6	200	1
HC/26	RACHET (FLAT, HARDENED)	M.S.		480	1
HC/27	TAIL VANE (1mm SHEET)	M.S.		2000x1000	1
HC/28	HELP VANE (1mm SHEET)	M.S.		1000x500	1
HC/29	ROD	M.S.		30Diax650	1
HC/30	WASHER	M.S.		M12(1/2" Dia.)	1
HC/31	NUT	M.S.		M22(W 7/8")	1
HC/32	BOLT,NUT,WASHER	M.S.		M12x40(W1/2"x1 1/2")	1
HC/33	BOLT,NUT,WASHER	M.S.		M12/100(W1/2"x4")	1
HC/34	BOLT,NUT,WASHER	M.S.		M6x25-(W1/4"x1")	12
HC/35	SPRING	SPRING STEEL	App. 30Dia.x1000x14		1

MOVING PARTS

Sl.No.	Item	Materials	Size mm	Measurements mm	No.
MP/1	MAIN SHAFT	M.S.	∅ 50(∅2")	1300	1
MP/2	PILLOW BLOCK (BEARING)-FYH & NTN		P210J-50±0.01 bore		2
MP/3	BUSH	M.S.	33x43x33		2
MP/4	BUSH (MOULDED)	NYLON	∅ 25x∅38x18		4
MP/5	BUSH	M.S.	∅20x∅40x44		1
MP/6	WASHER	M.S.	∅20x40∅x3		1
MP/7	CRANK BOLT (GKW MAKE)	M.S.	M20x75(W3/4"x3")		1
MP/8	NUT	M.S.	M20(W3/4")		1
MP/9	BOLT,NUT,WASHER	M.S.	M12x50(W1/2"x2")		2
MP/10	BOLT,NUT,WASHER	M.S.	M10x100(W3/8"x4")		2
MP/11	CROSS PIN	M.S.	∅ 25x92		1
MP/12	CROSS HEAD	WOOD	∅97x5x300		1
		(SEASONED In OIL)			
MP/13	CONNECTING ROD (FLAT)	M.S.	30x6	650	1
MP/14	FLAT	M.S.	30x6	50	4
MP/15	FLAT	M.S.	15x6	300	2
MP/16	FLAT	M.S.	40x10	165	1
MP/17	FLAT	M.S.	25x6	135	2
MP/18	FLAT	M.S.	25x6	250	2
MP/19	GREASE CUP				1
MP/20	PIPE (Q.S.T. MAKE) CLASS 'A' G.I.		∅1"		*
				(Amount or size depend upon - circumstances)	
MP/21	PUMP ROD GUIDE	(TEAK WOOD)	∅120x100		1

ROTOR:

Sl.No.	ITEM	MATERIAL	SIZE mm	MEASUREMENTS mm	NO. REQD.
R/1	PLATE	M.S.	260Dia.x6		2 (Two piece in one)
R/2	ANGLE IRON	M.S.	50x50x5	625	2
R/3	ANGLE IRON	M.S.	50x50x5	100	4
R/4	ANGLE IRON	M.S.	50x50x5	350	2
R/5	ANGLE IRON	M.S.	40x40x5	1880	6
R/6	FLAT IRON	M.S.	30x5	1880	6
R/7	FLAT IRON	M.S.	30x5	495	6
R/8	FLAT IRON	M'S'	30x5	275	6
R/9	RING CLAMP (FFLAT)	M.S.	40x10	150	12
R/10	OUTER RING (FLAT)	M.S.	30x5	2000	6
R/11	INNER RING (FLAT)	M.S.	30x5	3000	2
R/12	ROTOR BLADE (SHEET)	M.S.	2000x300x1.5		12
R/13	OUTER BLADE SUPPORT (SHEET)	M.S.	220x157x2.65		12
R/14	INNER BLADE SUPPORT (SHEET)	M.S.	250x247x2.65		12
R/15	BOLT, NUT, WASHER	M.S.	M16x100(W5/8"x4")		12
R/16	BOLT, NUT, WASHER	M.S.	M16x125(W5/8"x5")		2
R/17	BOLT, NUT, WASHER	M.S.	M10x25(W3/8"x1")		64
R/18	BOLT, NUT, WASHER	M.S.	M6x25(W1/4"x1")		120

PISTON PUMP

Sl.No.	Item	Material	Size mm	No. Reqd.
PP/1	PUMP ROD EXTENSION	G.I. PIPE	3/4"-----x*	*
PP/2	PUMP ROD	G.I. PIPE	3/4"-----x900	1
PP/3	PIPE	G.I. PIPE	5/8"-----x100	4
PP/4	TOP PIPE	BLACK PIPE	4"-----x750	1
PP/5	EXHAUST PIPE	BLACK PIPE	4"-----x*	1
PP/6	DELIVERY PIPE	BLACK PIPE	4"x-----x*	*
PP/7	T-SOCKET	G.I.	4"-----	1
PP/8	SOCKET	BLACK	4"-----	*
PP/9	DELIVERY PIPE	BLACK PIPE	4"-----	1
PP/10	CYLINDER	SEAMLESS BLACK PIPE	6" GASPIPE X 460	1
PP/11	CASING FLANGE	M.S.	φ 290	2
PP/12	CASING FLANGE	M.S.	φ 290	1
PP/13	CASING	C.R. SHEET	500x900	2
PP/14	FOOT VALVE	8 mm M.S. SHEET	φ 170	1
PP/15	FLAT IRON		-----35	12
PP/16	FLAT IRON		-----80	4
PP/17	FLAT IRON		-----x180	1
PP/18	FLAT IRON		-----x450	1
PP/19	FLAT IRON		-----x300	*
PP/20	FLAT IRON		40x6(1½"x¼")	3
PP/21	ANGLE IRON		40x40x4(1½"x1½")	2
PP/22	FILLING PIECES	M.S. ROD	φ 8mm x 10mm	8
PP/23	RING	M.S. ROD	φ 8(0 3/8")x870	1
PP/24	VALVE	NITRILE RUBBER WITH NYLON FABRIC INSERT/ LEATHER	φ 150 x 5	2
PP/25	GASKET	NITRILE RUBBER SOLE LEATHER	φ 290 x 6 mm	1
P/26	PISTON	POLYPROPELENE/ TEAK WOOD POLYPROPELENE		1
PP/27	STEEL BUSH		φ 43 x 33	*
PP/28	GUNMETAL BUSH		φ 33 x 30	*
PP/29	THREADED STUD	C.I.	M24x150(W7/8"x65)	1
PP/30	THREADED STUD	C.I.	M24x100(W7/8"x4")	*
PP/31	NUTS	G.I.	M24x(W7/8")	*

Sl.No.	Item	Material	Size mm	No. Reqd.
PP/32	SPRING WASHER	G.I.	M24(W7/8")	*
PP/33	BOLT,NUT,WASHER *	G.I.	M12x125(W1/2"x5")	4
PP/34	BOLT,NUT,WASHER *	G.I.	M12x120(W1/2"x3/4")	1
PP/35	CLAMP (U BOLT)	M.S.	φ 12 (1/2") x370	
PP/36	TEAK WOOD/POLYPRO- PELENE GUIDE	TEAK WOOD	(5"x5"x4")	1

**Nylock bolts x nuts are preferred to avoid their frequent loosening.*

9.9 INVENTORY OF MINIMUM SPARES OILS AND LUBRICANTS

Sl. No.	Component	Qty.	Reference of fabrication drawing	Part number on the drawing
1.	Help vane spring	1	Head construction 12-PU-500	35
2.	Help vane frame with ratchet	1	"	18,25,26
3.	Tail pin	1	"	29
4.	Connecting rod	2	Moving parts	3,13,14,15,19
5.	Nylon bush (4 nos. at a time)	8	"	4
6.	Crank pin	2	"	5
7.	Crank pin bolt and nut	1	"	7 & 8
8.	Cross head with cross pin	1 st.	"	11 & 12
9.	Wooden guides	2 pairs	"	21
10.	Pillow blocks N.T.N. Japan	1 pairs	"	2
11.	PVC sleeve for tower pipe	1	Tower 12-PU-500	13
12.	Blades coated with 90% zinc rich primer and enamel paint	3	Rotor & blade	12
13.	Blade supports (inner & outer)	3 pairs	"	13 & 14
14.	Piston valve & suction valves	3 each	Windmill pump	18,37,38,4
15.	Pump gasket	1	"	17
16.	Piston (polypropelene)	2	"	27
17.	Pump rod guide (brass)	2	"	25
18.	Pump rod guide bush	2	"	23
19.	Pump rod connection	1	"	30,32
20.	Galvanised fasteners with nylock nuts and plain washers (1/4" x ϕ x 1" long)	10	"	-
21.	Galvanised fasteners with nuts and plain washers (3/8" ϕ x 1 1/2")	40	"	-
22.	Galvanised fasteners with nylock nuts and plain washers 1/2" ϕ x 1 1/2" long)	10	"	-
23.	Galvanised fasteners with nylock nuts and plain washers 5 1/8" ϕ x 1 1/2" long)	10	"	-
24.	Grease for bearings	1/2 Kg.	"	-
25.	SAE 40 mobile oil	1 Lit.	"	-

9.10 SOURCES OF AVAILABILITY OF SPARES

(a) State Nodal Agencies:

1. Andhra Pradesh (BHEL) Bharat Heavy Electricals Ltd.
Vikas Nagar,
Hyderabad-500 593.
2. Andhra Pradesh (NEDCAP) Non-Conventional Energy Development Corporation
10-2-318/1/A/5/1, Indranagar Colony
Hyderabad-500 457.
3. Bihar Executive Engineer,
Solar Division,
Sone Bhawan,
Beer Chand Patel Marg,
Patna.
4. Delhi (DEDA) Delhi Energy Development Agency,
11, Lancer Road, Timarpur,
Delhi-110 007.
5. Gujarat (GEDA) Gujarat Energy Development Agency,
P.N. Chambers, 3rd Floor,
Vadodra- 390 005.
6. Himachal Pradesh (HPSEB) Himachal Pradesh State Electricity Board,
Shimla, H.P.
7. Madhya Pradesh (MRUVN) Madhya Pradesh Urja Vikas Nigam,
B-Block, G.B.T. Complex, T.T. Nagar,
Bhopal, M.P.
8. Maharashtra (MEDA) Maharashtra Energy Development Agency,
3rd Floor, Mantralaya,
Bombay-400 023.
9. Orissa (OREDA) Orissa Renewable Energy Development Agency,
5-57, Mancheswar, Industrial Estate,
Bhubaneswar-751 010.
10. Rajasthan (REDA) Rajasthan State Agro Industries Corporation Ltd.
O.I. Subhash Nagar, Ghotwara Road,
Jaipur-6.
11. Tamilnadu (TEDA) Tamil Nadu Energy Development Agency,
Jhaver Plaza, IVth Floor,
1-Nungambhakkam High Road,
Madras.
12. Uttar Pradesh (NEDA) Non-Conventional Energy Development Agency,
B-46, Mahanagar Extension,
Lucknow-226 006.

9.11 FABRICATING AGENCIES

(b) Fabricating Agencies:

(Involved during demonstration Programme)

1. Andhra Pradesh Non-Conventional Energy Development Corporation,
10-2-3/8/1/A/5/1, Indranagar Colony,
Hyderabad-500 457.
2. Gujarat Principal,
Community Polytechnic Wing,
Government Polytechnic,
Porbandar,
Gujarat-360 577.
3. Madhya Pradesh Principal,
Government Polytechnic,
Khurai,
Distt. Sagar-470 117, M.P.
4. Orissa Chief Executive,
Orissa Renewable Development Agency,
5-57, Mancheshwar Industrial Estate,
Bhubaneswar-751 010.
5. Punjab Principal,
Ramagarthia Polytechnic
Phagwara
P.O. Satnampura-144 402.
6. Uttar Pradesh Works Manager,
Training-Cum-Production-Centre,
Institute of Engineering & Rural Technology,
26, Chatham Lines,
Allahabad-211002, U.P.

LORP
(TOOL-ORP Project)
Kusumikalan,
Gazipur, U.P.
7. Tamilnadu Principal,
Murugappa Polytechnic
Satyamurthy Nagar,
Avadi,
Madras-600 062.

10.1 POLYPROPELENE CROSS HEAD

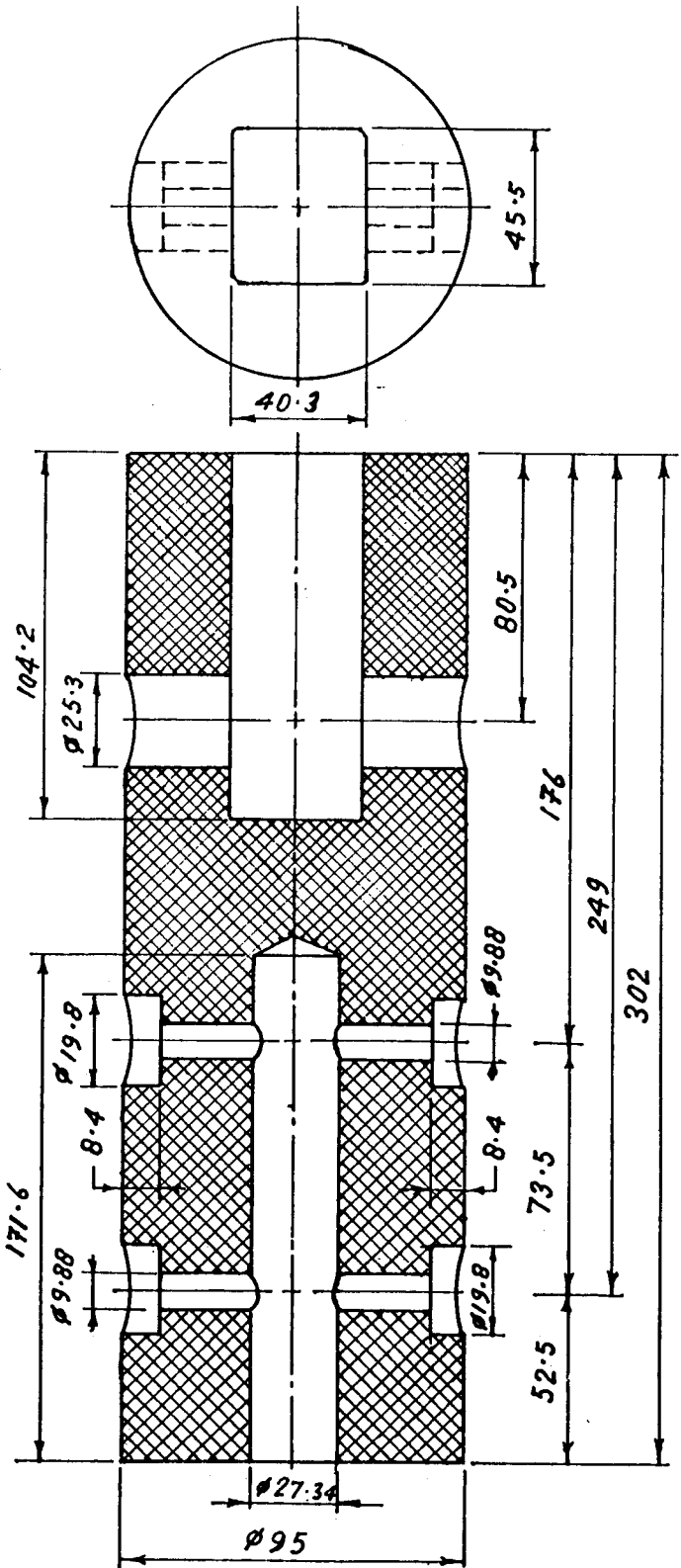

Fig, 13 Polypropelene cross head

10.2 BALL & SOCKET JOINT

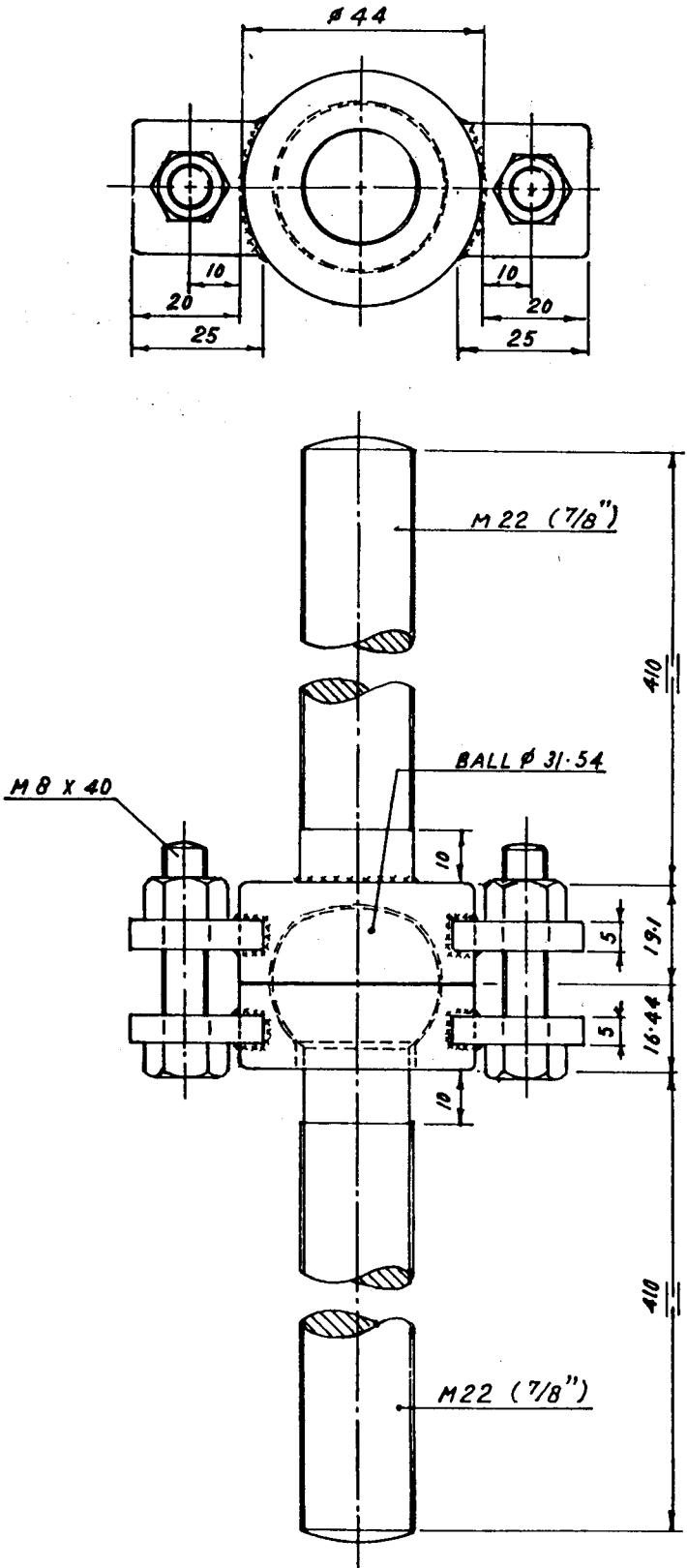
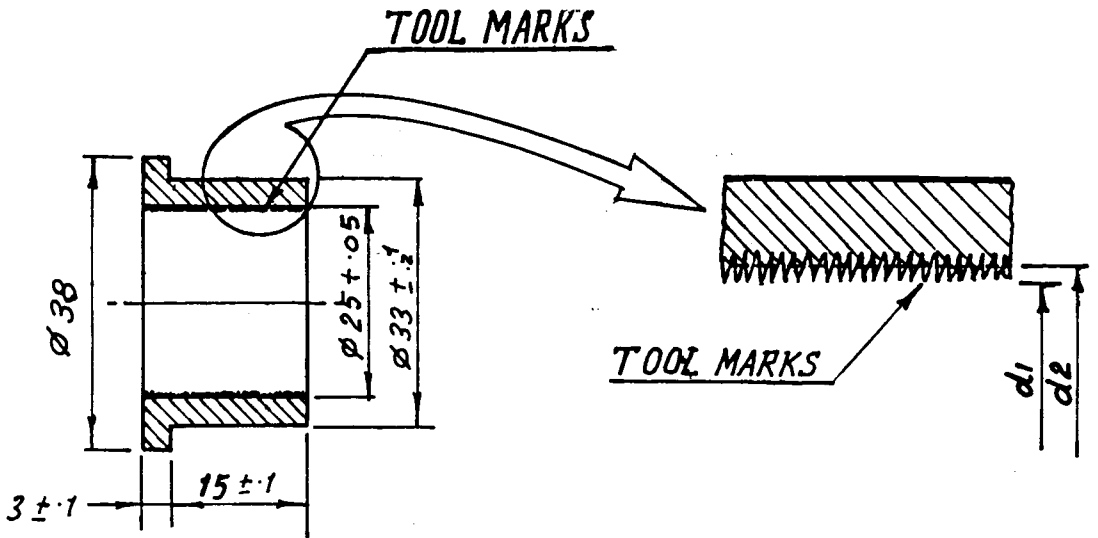
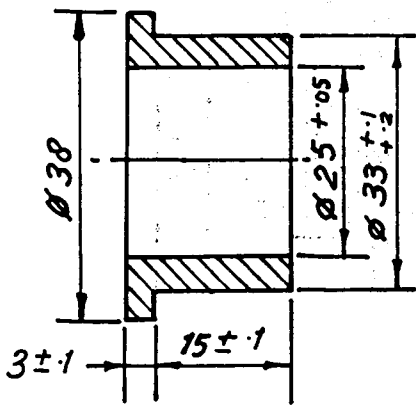

Fig. 14 Ball & Socket joint

10.3 NYLON BUSH FABRICATED AND NYLON BUSH MOULDED



Nylon Bush (fabricated)



Nylon Bush (Moulded)

10.4 NEOPRENE VALVE WITH NYLON FABRIC INSERT

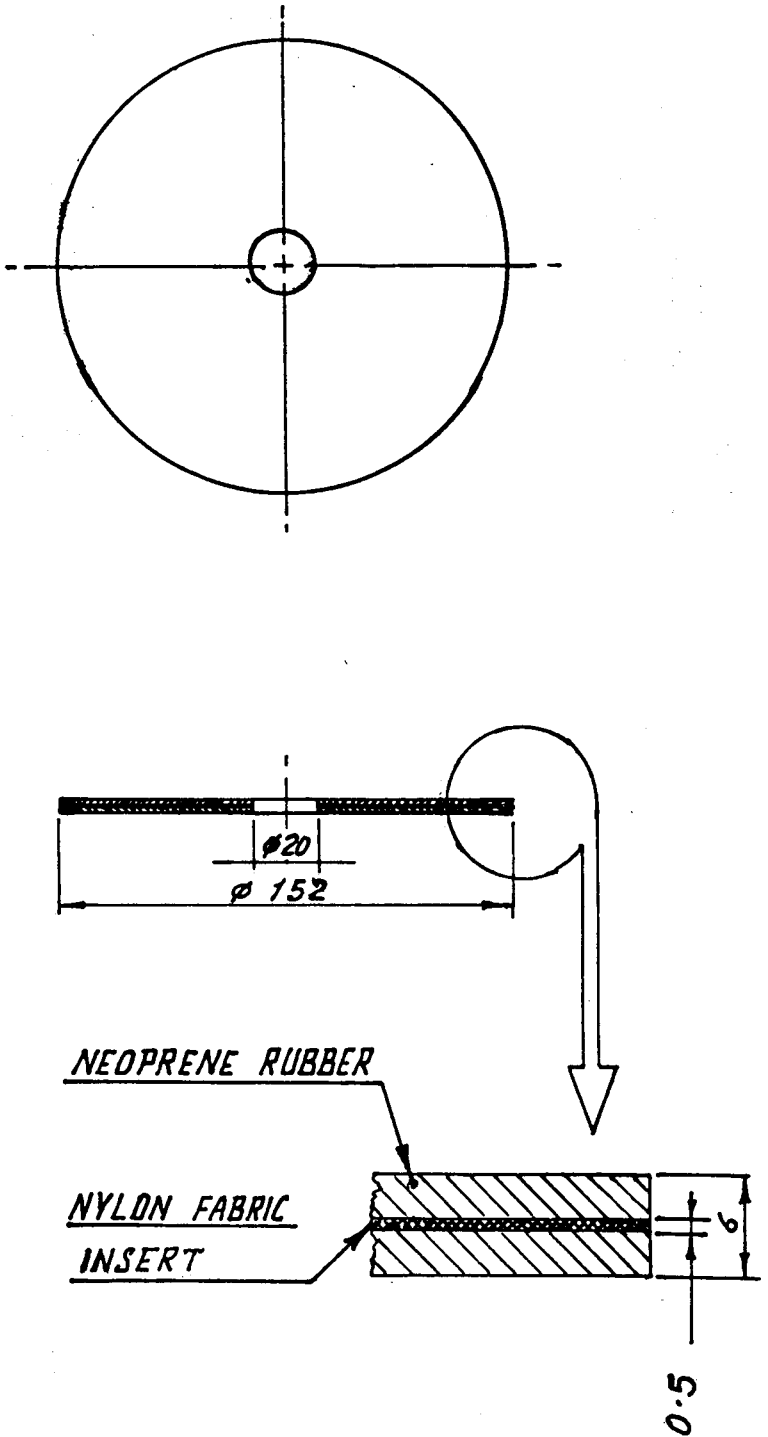

Fig. 16 Neoprene Valve with Nylon Fabric Insert

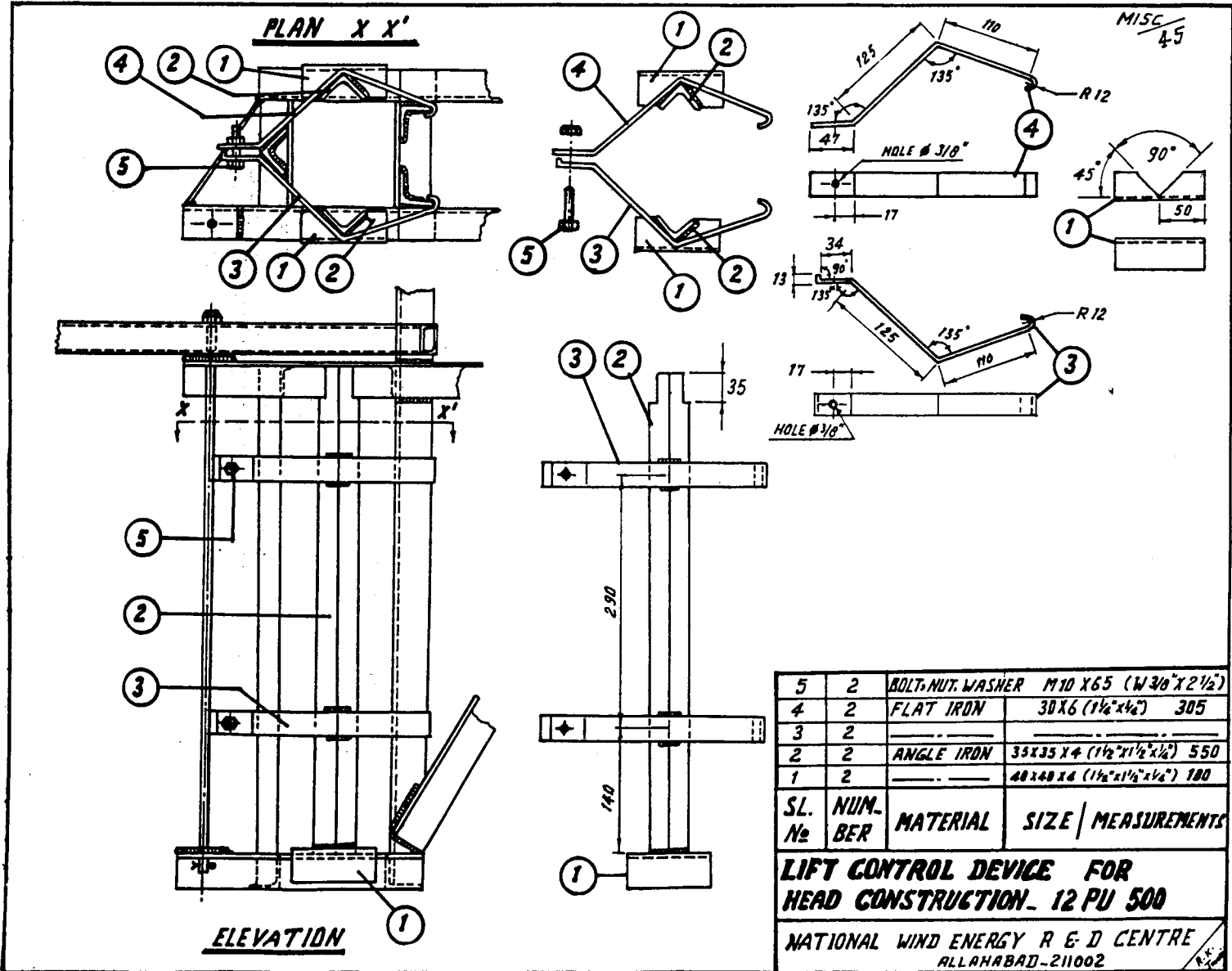
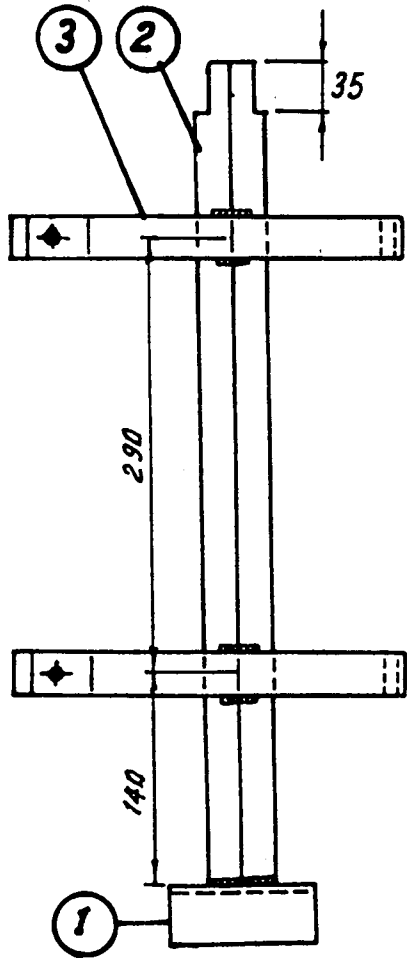
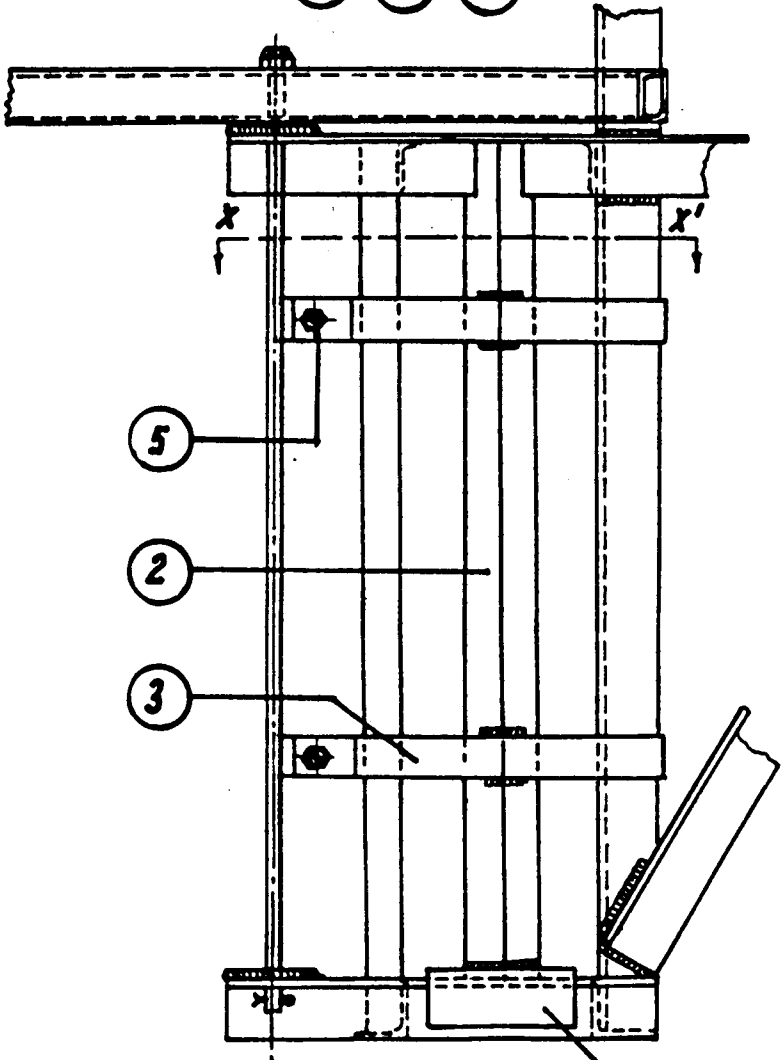
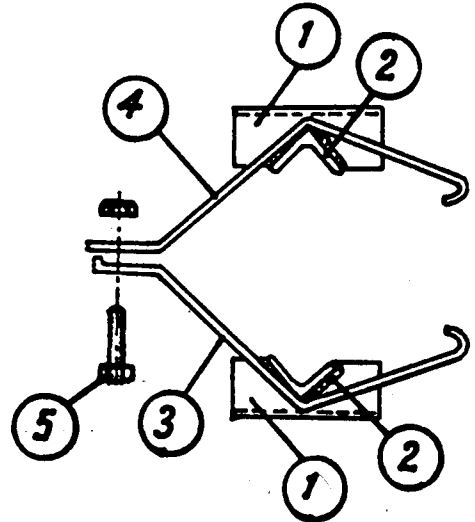
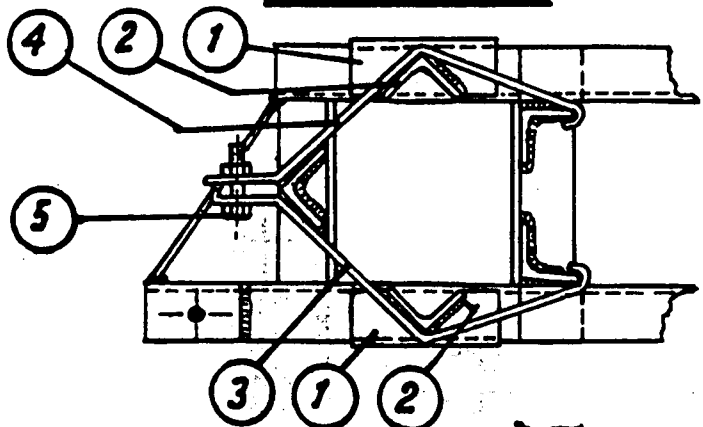

Fig. 17

PLAN X X'



ELEVATION

1

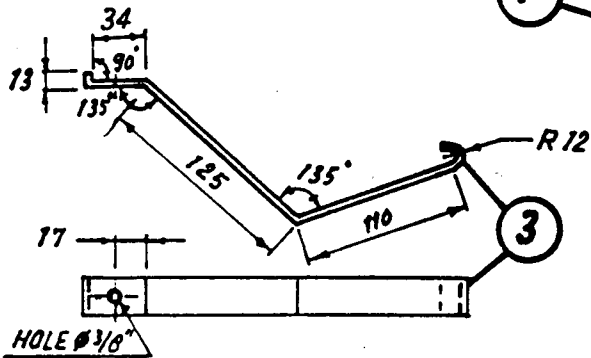
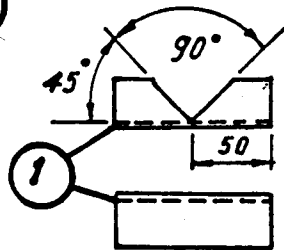
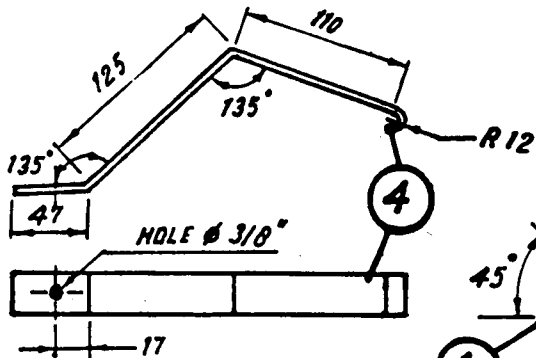

10.6 WOODEN CROSS HEAD WITH STEEL REINFORCEMENT

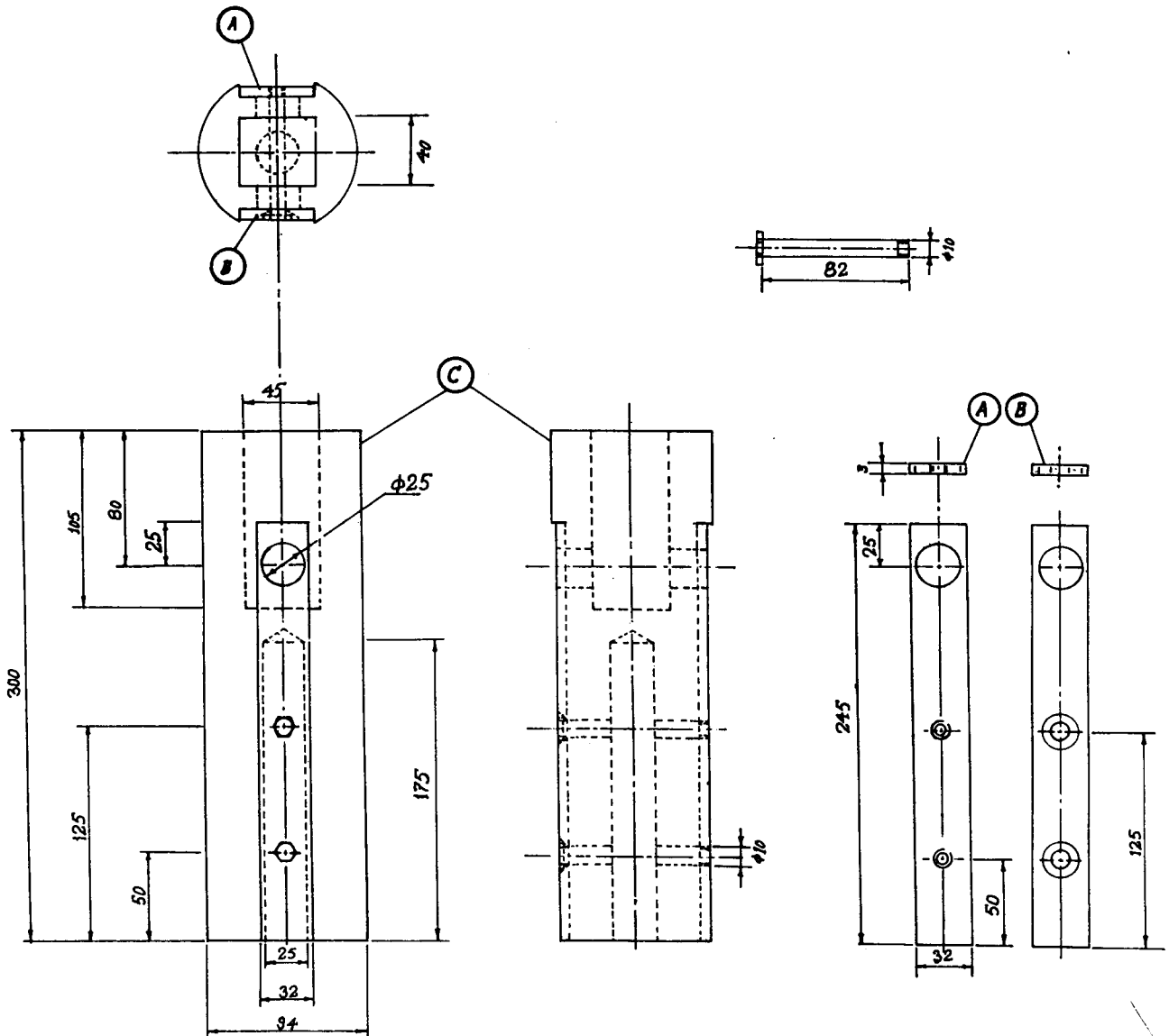

A	FLAT IRON WITH INTERNAL THREAD $M25$
B	CHAMFERED DRILL
C	WOODEN CROSS HEAD

Fig. 23 Wooden Cross Head with Steel Reinforcement

11. MERITS OF THE NEW PUMP "A RECIPROCATING PUMP WITH C.I. CYLINDER"

NEW WINDMILL PUMP WITH CAST IRON CYLINDER:

(Special features over the old pump of Nick design).

- (1) Volumetric efficiency is comparable. It is as high as 95.00 percent as compared to 69.00 percent of old pump of Nick design.**
- (2) Can be installed above the well, integrated with tower structure, so that pump axis coincides with the axis of the tower pipe thus eliminating the problem of misalignment which has hitherto being treated as difficult to achieve practically. This is because of the fact that the suction valve is all metallic (brass) and does not contain leather or rubber washers.**
- (3) Accurately machined and honed cylinder gives uniform bore and eliminates the ovality which is almost impracticable in the case of cylinders made out of M.S. pipes.**
- (4) Clearance between the bore and the piston has also been reduced to 0.1 mm uniformly. (The minimum achievable clearance in case of old pump of Nick design is 0.75 mm) with further decrease in clearance, the cylinder wall which is made of M.S. pipe, becomes too thin. The corrosion sets in the thin wall which leads to leakage within a short period.**

The cylinder made of cast iron, ensures longer operational life and makes it rust resistant.

- (5) Spherical suction valve makes it priming free provided, of course, the water is free from substances, like coarse grit, pebbles, floating leaves, twigs etc.**
- (6) Light in weight, fully galvanised pump body ensures corrosion and rust free service in adverse atmospheric conditions.**
- (7) Totally metallic suction valve assembly offers long life and trouble free service.**
- (8) Detachable suction valve of the pump makes the inspection of the suction valve and the piston of the pump easier and simplifies the replacement if necessary, unlike the old system where the complete heavy pump is to be taken out of the well for even petty repairs.**
- (9) Inspection and repairs can be further simplified because of convenience in installation of the pump above the well.**

18	120	NYLOCK NUT, BOLT, WASHER, M6 X 25 (W 1/4" X 1")	
17	64	NUT, BOLT, WASHER, M10 X 25 (W 3/8" X 1")	
16	2	" " " M16 X 125 (W 5/8" X 5")	
15	4	" " " M16 X 100 (W 5/8" X 4")	
14	12	1' BLADE SUPPORT M.S. SHEET, 11 B.G. 2.80 MM. THICK	9.90
13	12	0' BLADE SUPPORT " " " " " " "	5.04
12	12	ROTOR BLADE " " 16 B.G. 1.6 MM. " "	90.00
11	2	INNER RING M.S. FLAT 30 X 5 3000	7.2
10	6	OUTER RING " " " " 2000	14.4
9	12	RING CLAMP " " 40 X 10 150	5.58
8	6	M.S. FLAT ————— 30 X 5 275	2.22
7	6	" " ————— " " 495	3.6
6	6	" " ————— 1880	13.56
5	6	ANGLE IRON ————— 40 X 40 X 5 1880	8.8
4	2	" " ————— 50 X 50 X 5 350	2.6
3	4	" " ————— " " 100	1.52
2	2	" " ————— " " 625	4.5
1	2	M. S. PLATE ————— ϕ 260 X 6	2.4

SL. No.	No REQD.	MATERIAL NAME / SIZE / MEASUREMENTS	Wt. IN KG.
---------	----------	-------------------------------------	------------

ROTOR - FOR - 12 PU 500 WINDMILL

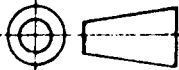
	DESIGNED BY	DRAWN BY <i>(K.K. Tiwari)</i> TRD. - Man Singh	CHECKED BY <i>(Signature)</i> PRATAP SINGH	APPROVED BY	SCALE N.T.S.
---	-------------	--	--	-------------	---------------------

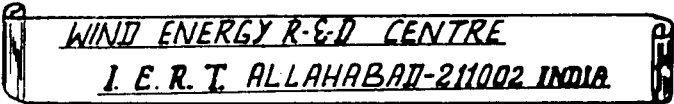
FOR INFORMATION	 <p style="text-align: center;">WIND ENERGY R-&D CENTRE I. E. R. T. ALLAHABAD-211002 INDIA</p>
----------------------------	--

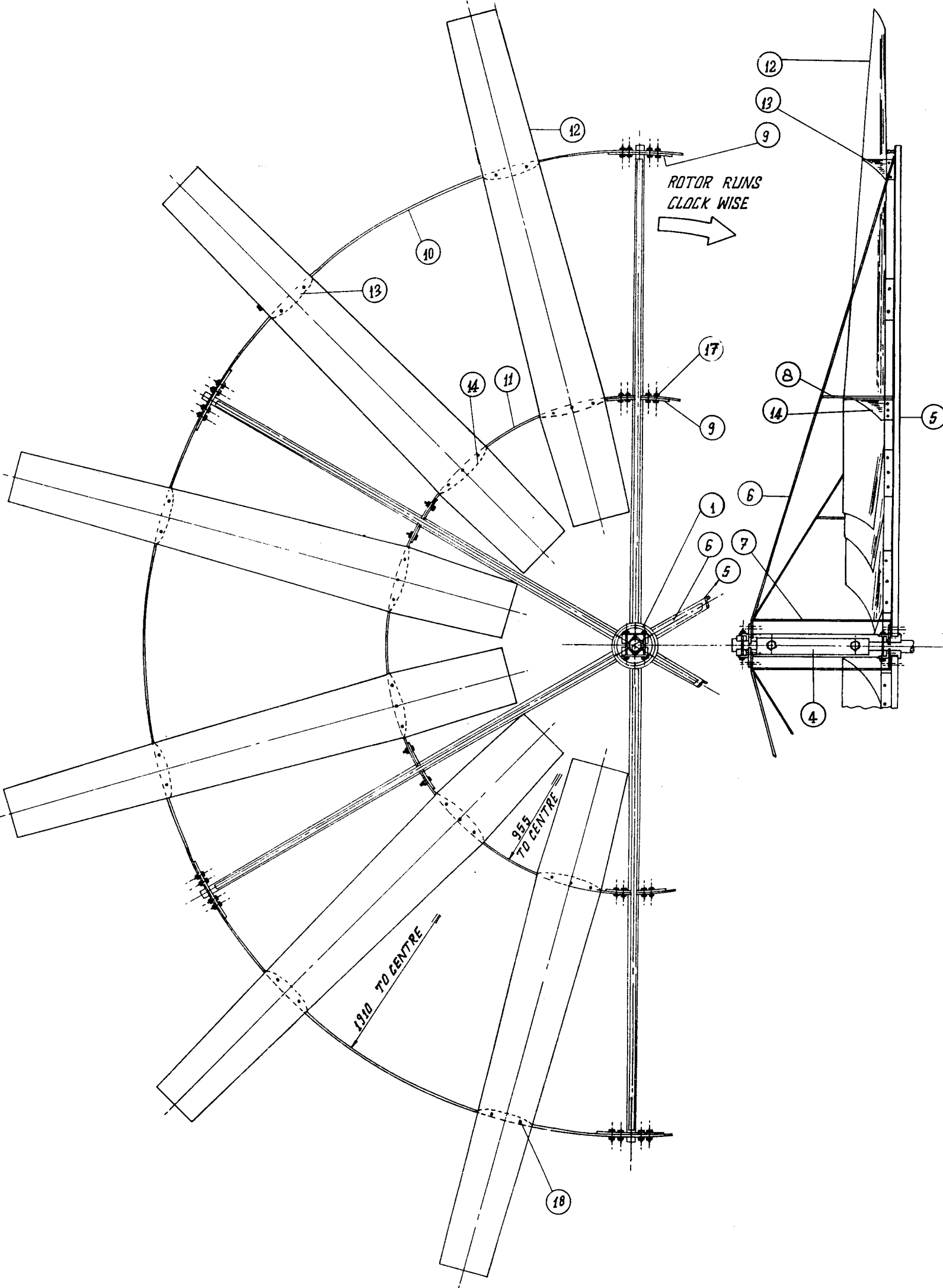

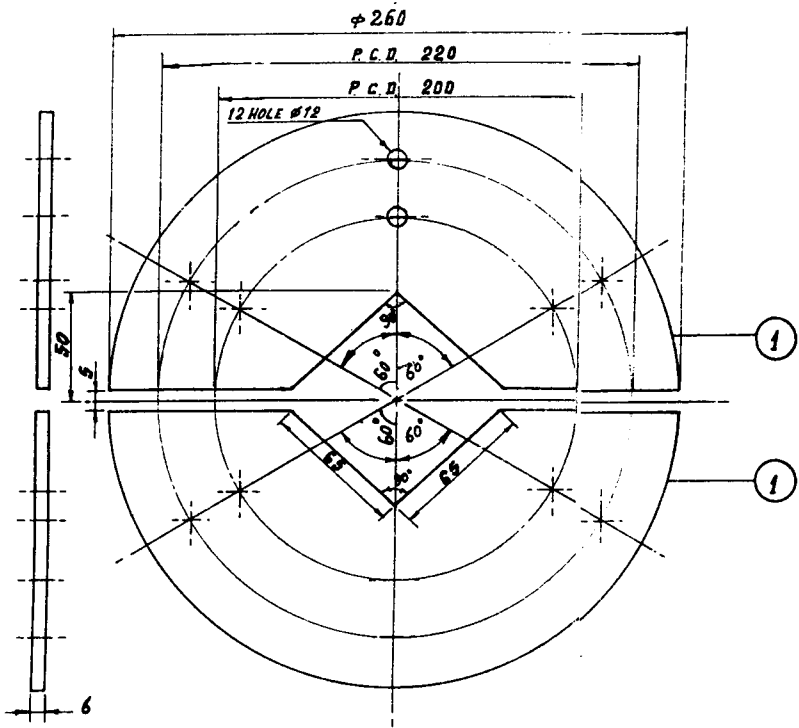

DETAIL ITEM No 1 (HUB PLATE)

DETAIL ITEM No 2 & 3 ROTOR (HUB)

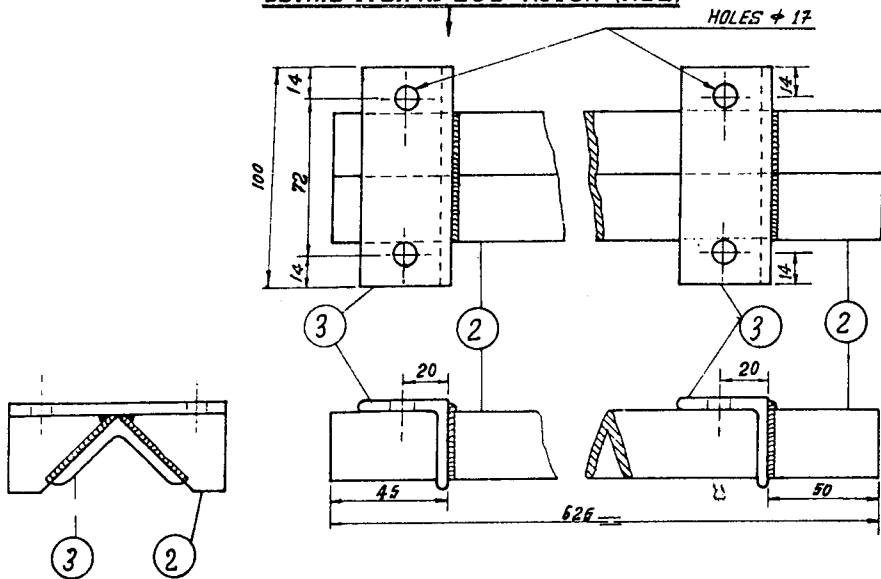

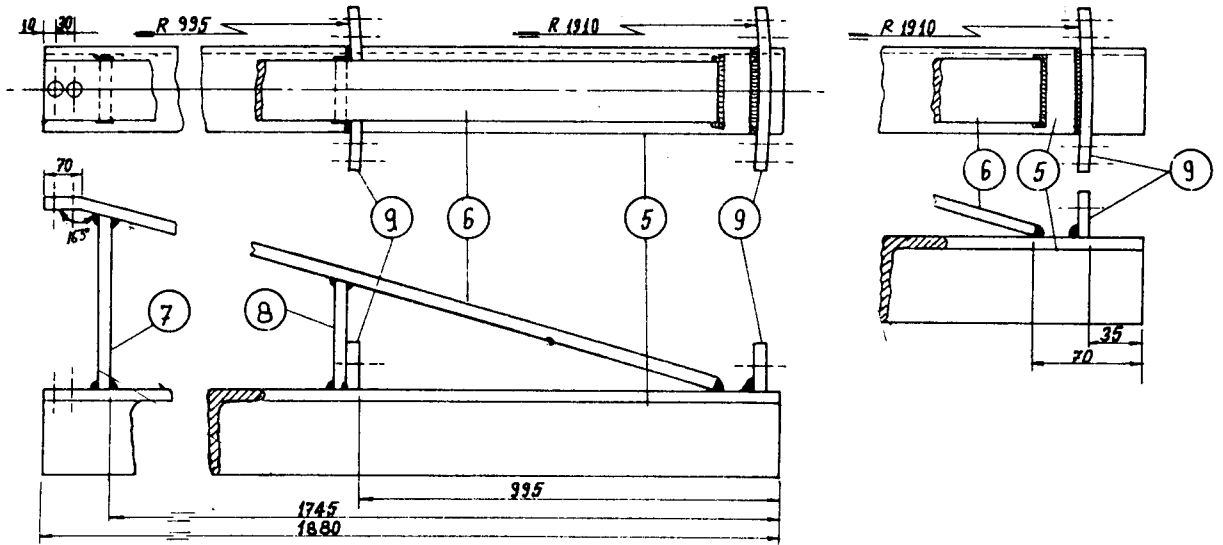

DETAIL ITEM No 5, 6, 7, 8, 9, ROTOR SPOKE

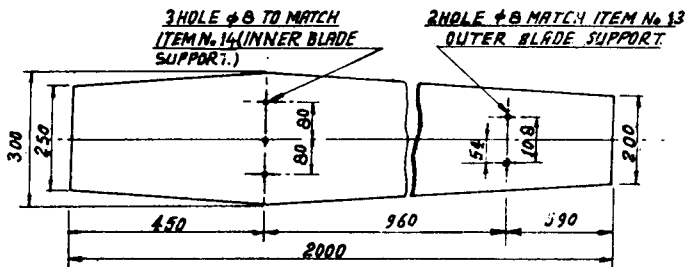

DETAIL ITEM No 12 (ROTOR BLADE)

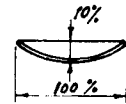

SHEET IS ROLLED IN A BENDING RADIUS OF APPR. 200 mm.

AFTER CUTTING THE RADIUS IS CORRECTED SO THAT 10% CURVED AIRFOILS WILL RESULT.

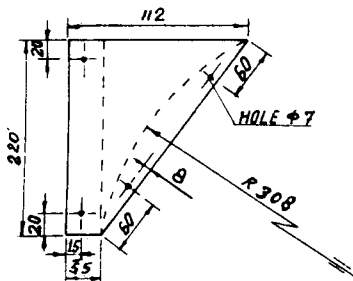

**DETAIL ITEM No 13
OUTER BLADE SUPPORT**

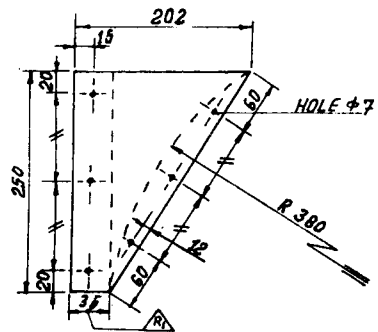

**DETAIL ITEM No 14
INNER BLADE SUPPORT**

DETAIL ITEM No 11 (INNER RING)

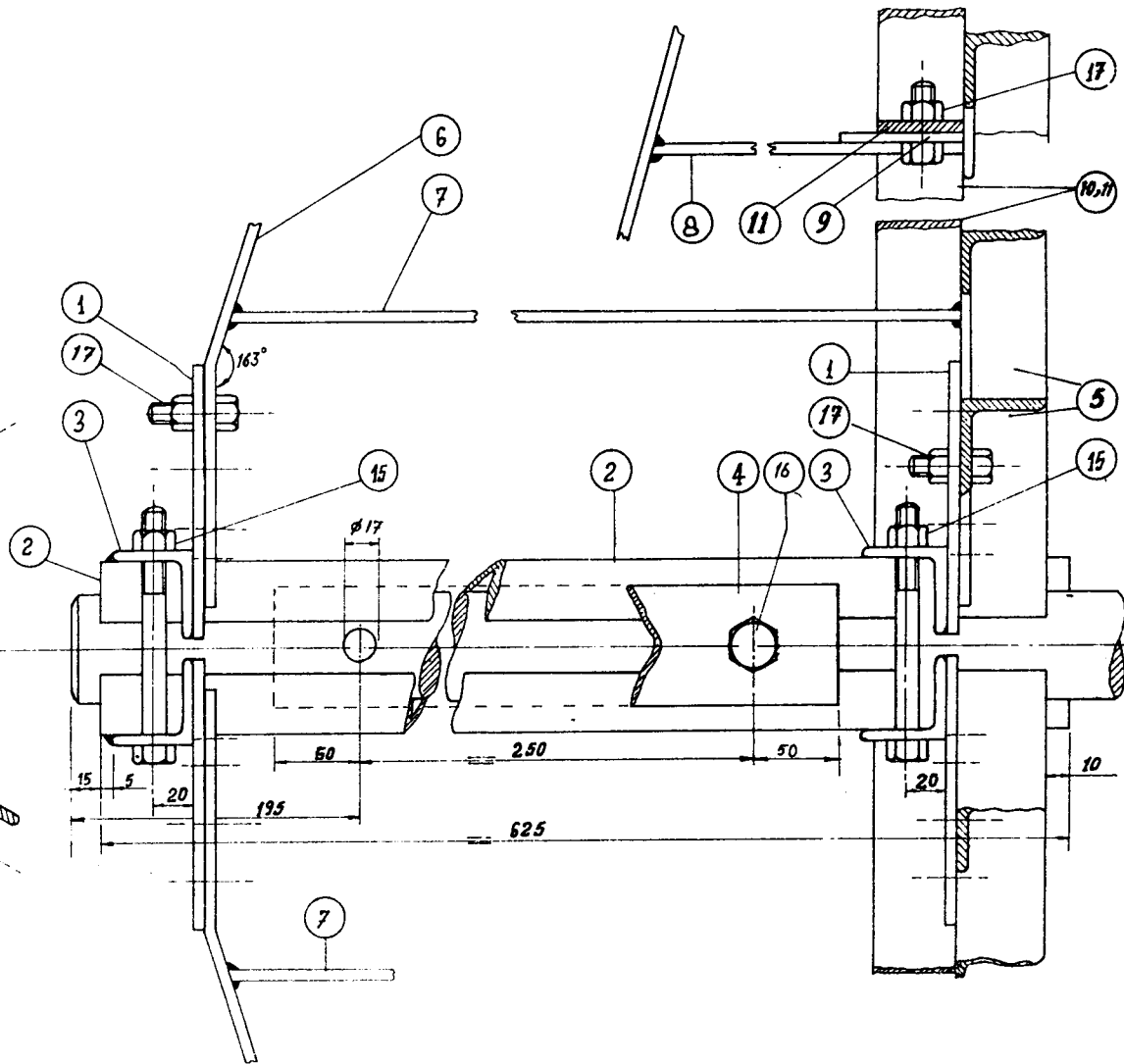
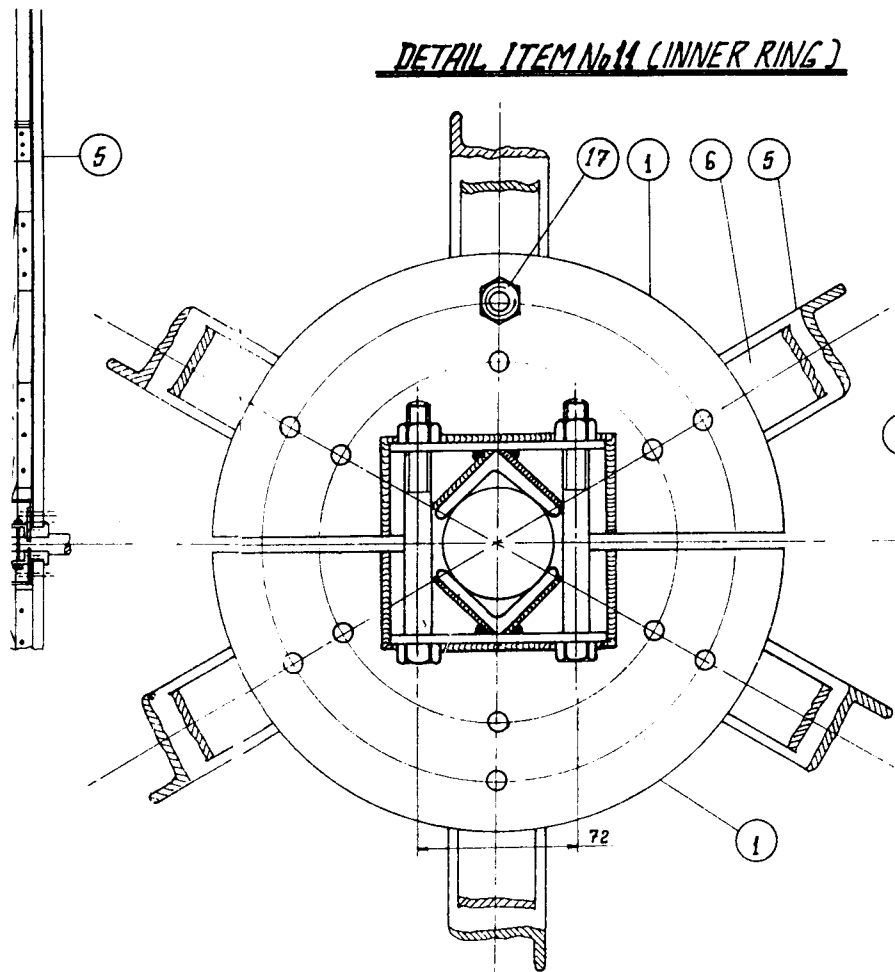

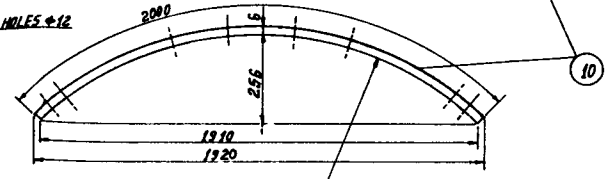
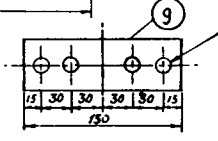
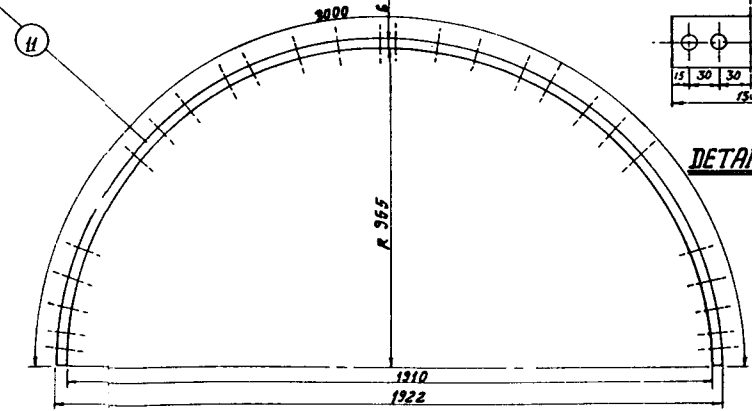
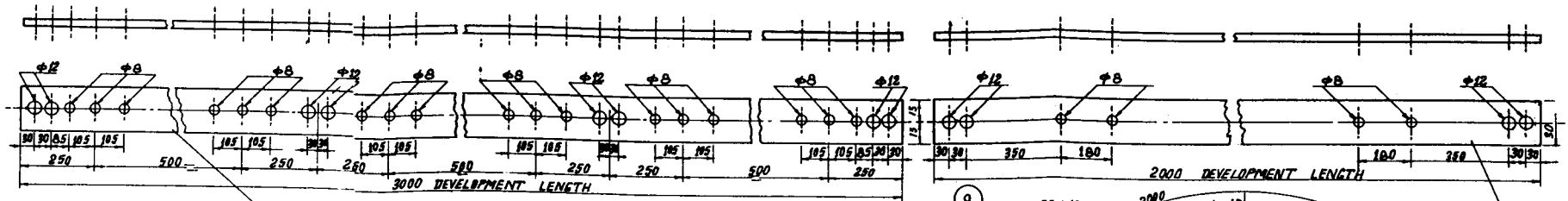

DETAIL ITEM # 11 (INNER RING)

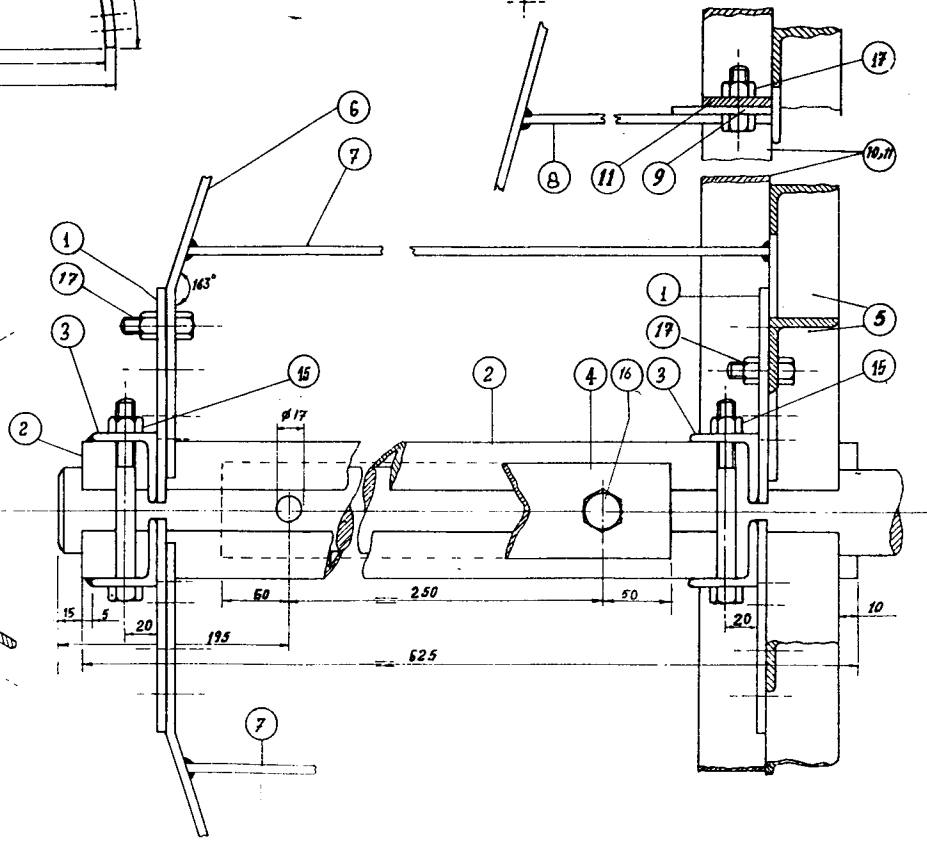
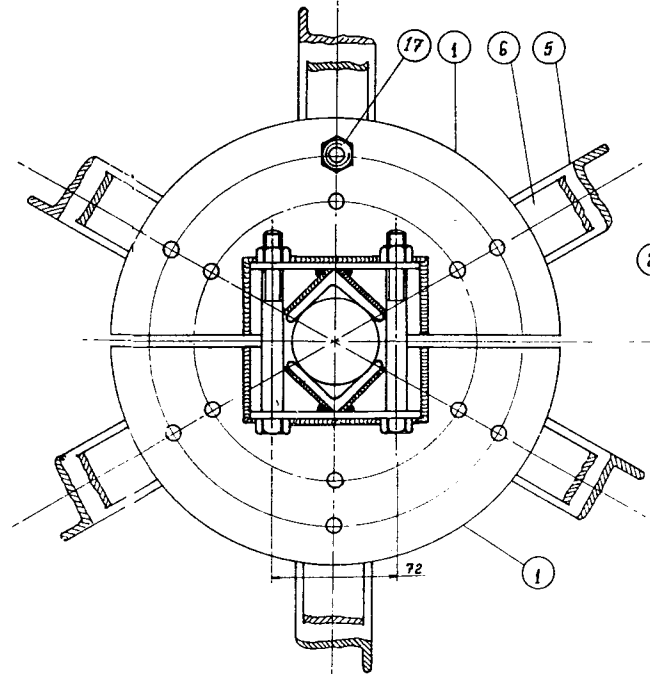

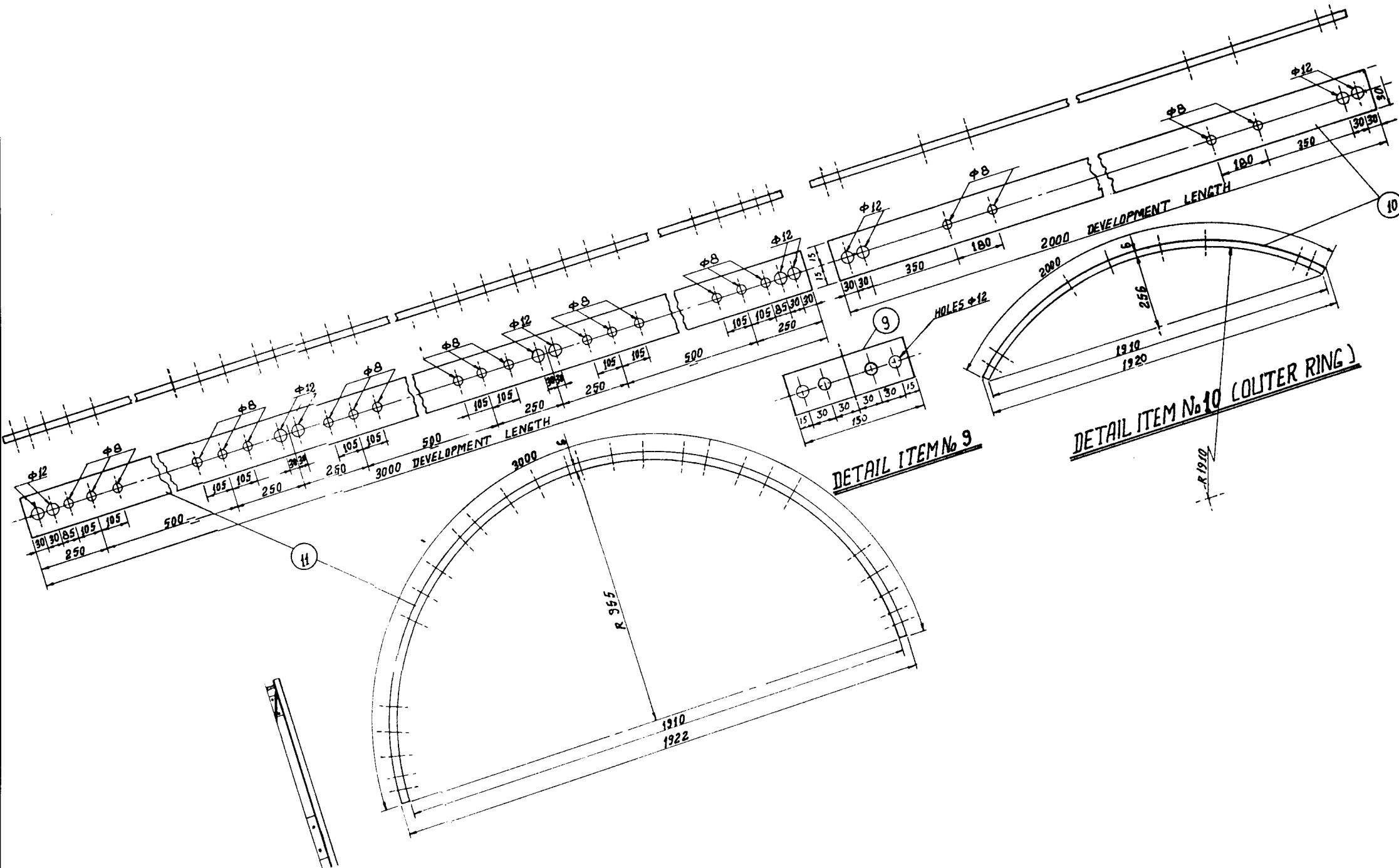

17	52	NUT, BOLT, WASHER, M12 X40 (W $\frac{1}{2}$ " X $\frac{1}{2}$ ")	
16	4	M.S PLATE ----- 170X150X6	
15	4	FLATE IRON ----- 32X6	410
14	1	TOWER PIPE ----- (4" N.B) B-GRADE	2650
13	1	P. V. C SLEVE PIPE - (4" BORE)	710
12	2	PLANK ----- 30X200X700	
11	2	FLATE IRON ----- 32 X 6	340
10	2	" " ----- " "	460
9	2	" " ----- " "	580
8	2	ANGLE IRON ----- 35X35X5	660
7	4	" " ----- 40X40X6	2000
6	4	" " ----- 35X35X5	700
5	4	" " ----- 50X50X6	250
4	4	" " ----- 35X35X5	1400
3	16	" " ----- " " "	1940
2	4	" " ----- 40X40X5	4500
1	8	" " ----- 35X35X5	250

S.L. No	No REQD	MATERIAL NAME/SIZE / MEASUREMENTS	REMARKS
---------	---------	-----------------------------------	---------

TOWER-FOR 12 PU 500 WIND MILL

DESIGNED BY	DRAWN BY E.H.H. SHARADWAN SINGH	CHECKED BY <i>[Signature]</i> PRATAP SINGH	APPROVED BY	SCALE, N.T.S.
-------------	---------------------------------------	--	-------------	------------------

FOR
INFORMATION

WIND ENERGY R-&D CENTRE
I.E.R.T. ALLAHABAD - 211002. INDIA.

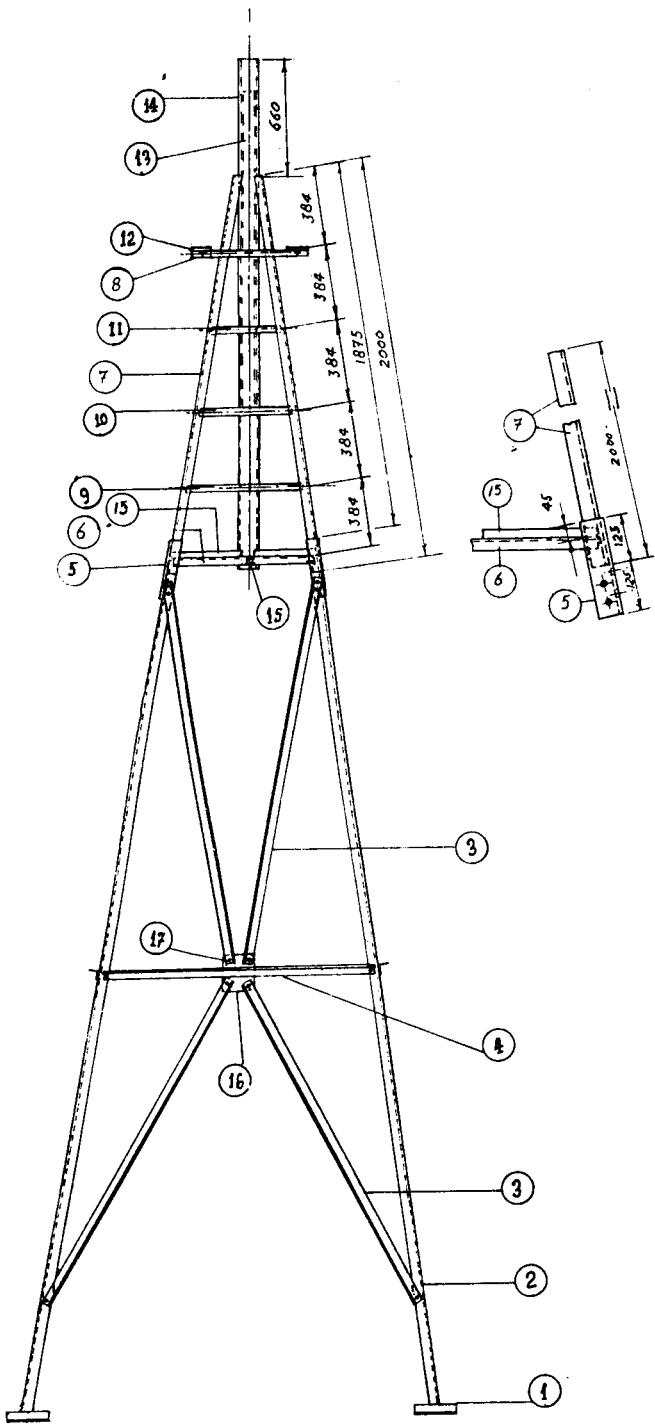

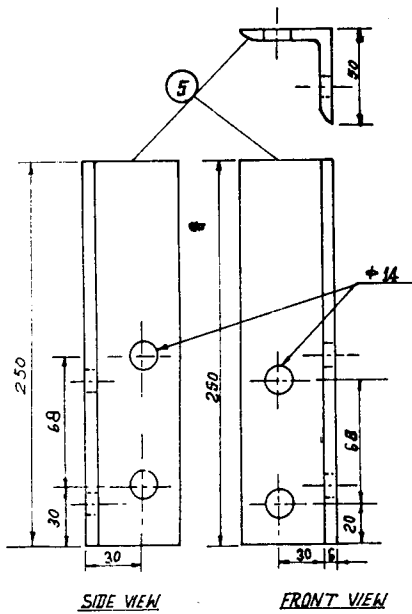
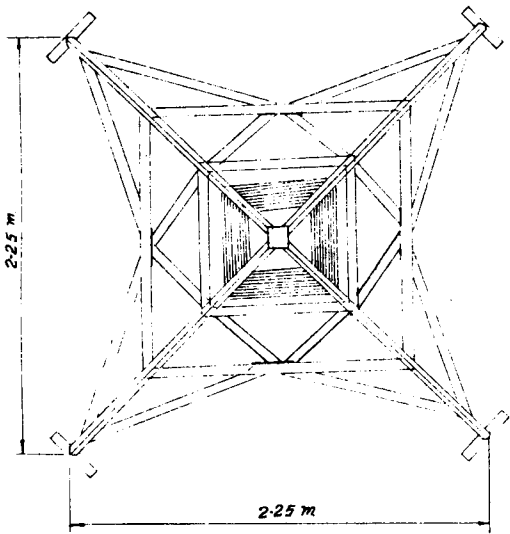

TOWER TOP & TOWER LEG JOINTER (OUTER)

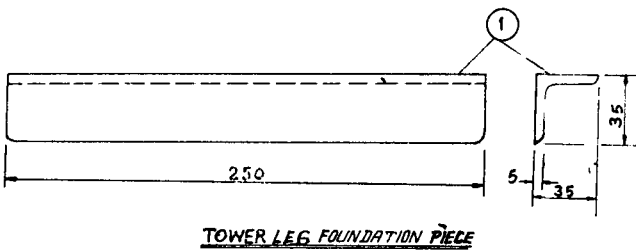
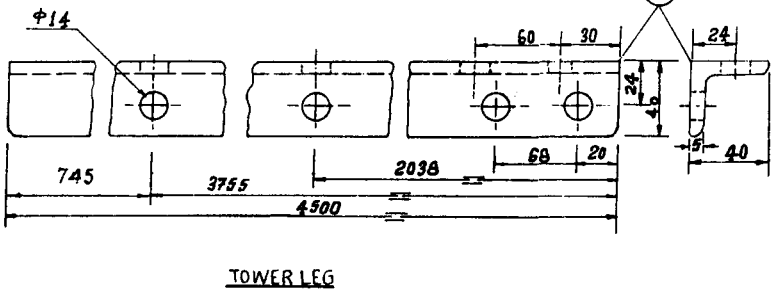
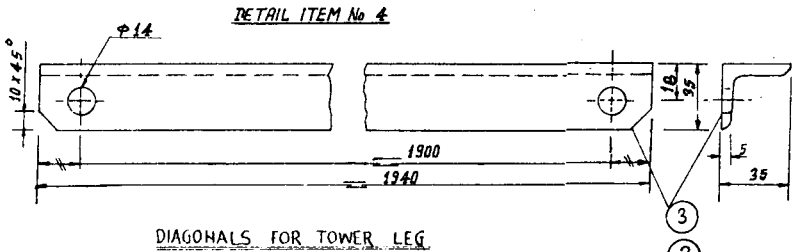
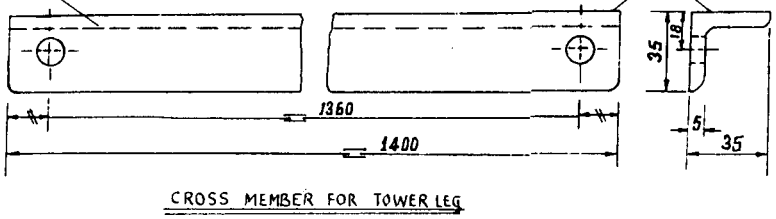
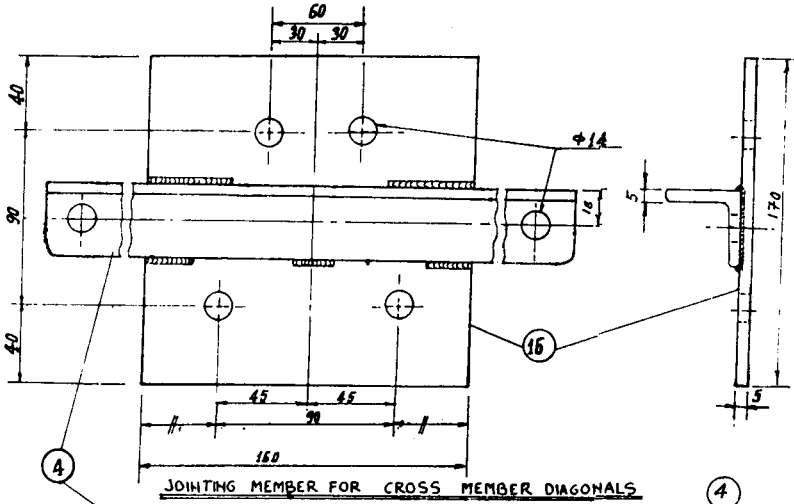
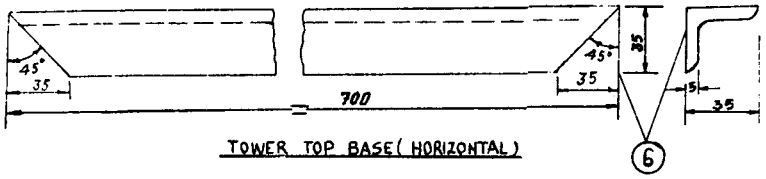

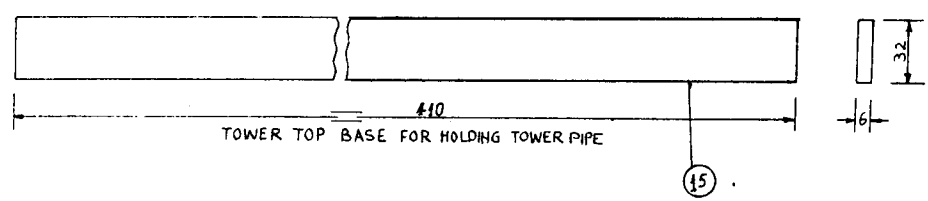
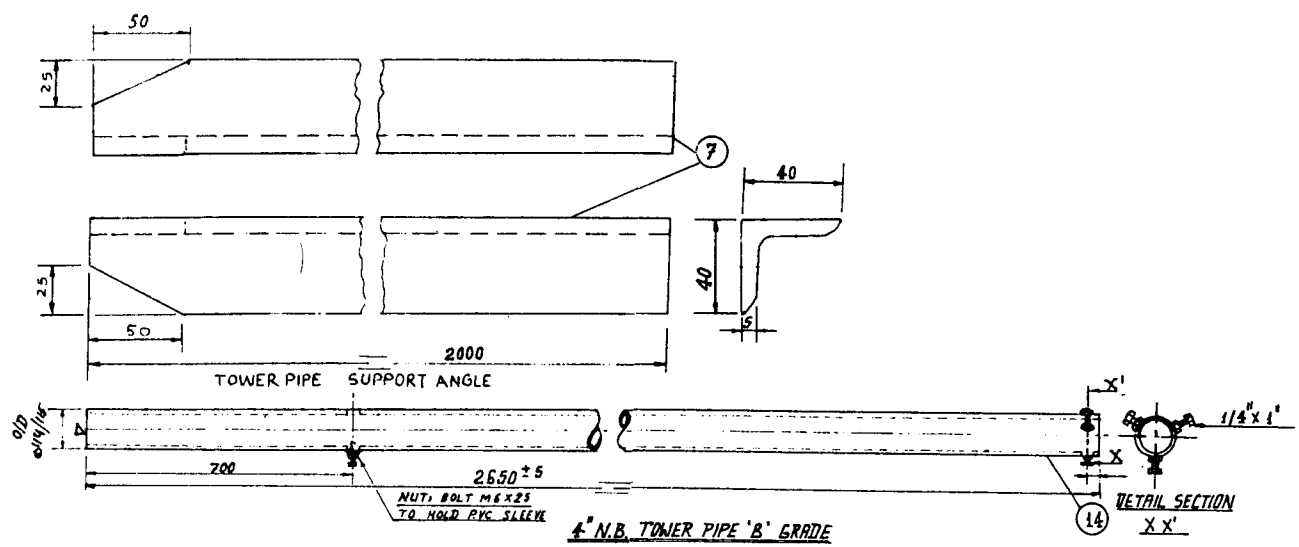
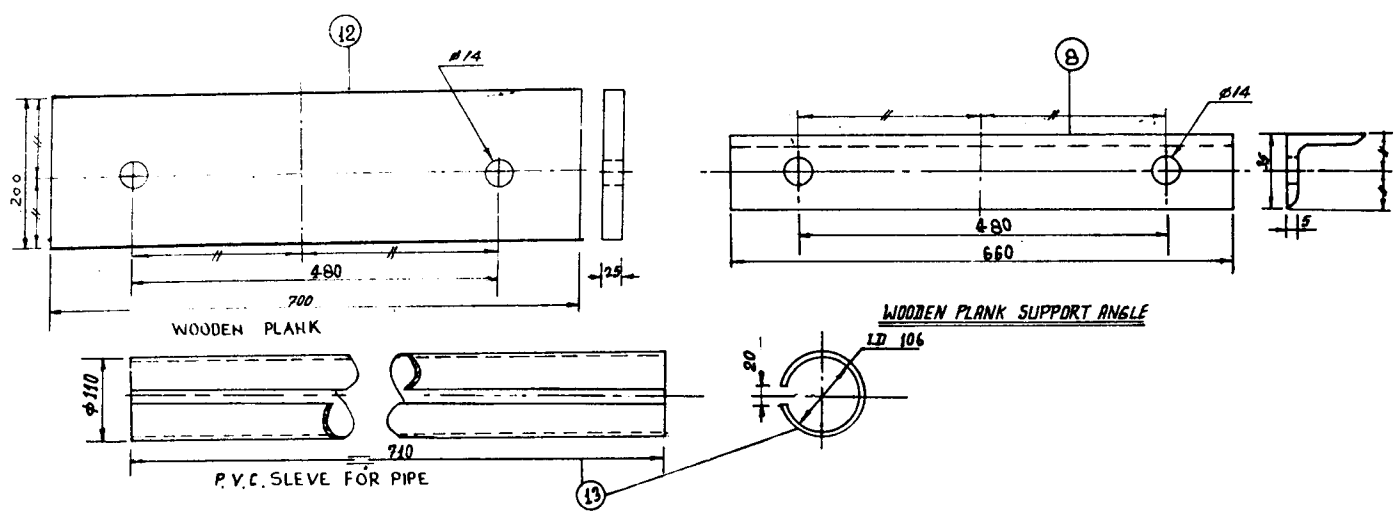
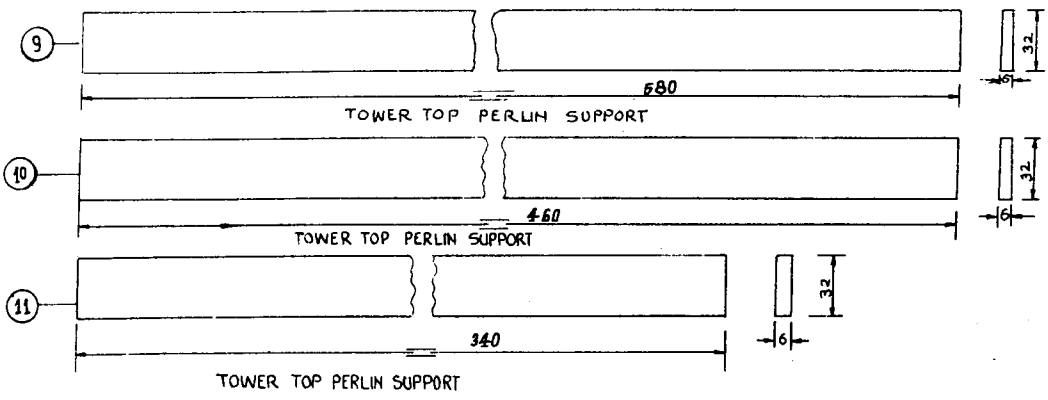

35	1	SPRING APP	$\phi 30 \times 100 \times \phi 4$	
34	12	M.S. BOLT, NYLOCK NUT, WASHER	M6 X 25 (W $\frac{1}{2}$ " X 1")	
33	1	M.S. BOLT, " " "	M12 X 100 (W $\frac{1}{2}$ " X 4")	
32	1	M.S. BOLT, " " "	M12 X 40 (W $\frac{1}{2}$ " X 1 $\frac{1}{2}$ ")	
31	1	M.S. NYLOCK NUT	M22 (W 7/8")	
30	1	M.S. WASHER	M12 (W 1/2")	
29	1	M.S. ROD	$\phi 20 \times 690$	
28	1	HELP VANE 1 M.M SHEET	1000 X 500	
27	1	TAIL VANE	2000 X 1000	
26	1	RACHET FLAT IRON HARDEND	32 X 6 LENGTH - 480	
25	1	FLAT IRON	32 X 6 " - 900	
24	3	" "	" " - 750	
23	1	" "	" " - 830	
22	1	" "	" " - 115.5	
21	1	" "	" " - 130	
20	2	" "	" " - 60	
19	2	" "	(WEARING FLATES) " " - 115.5	
18	1	ANGLE IRON	40 X 40 X 5 - 1000	
17	1	" "	" " - 45	
16	1	" "	" " - 60	
15	1	" "	" " - 125	
14	1	" "	" " - 3000	
13	1	" "	" " - 4000	
12	1	" "	" " - 1500	
11	2	" "	65 X 65 X 6 - 250	
10	1	" "	40 X 40 X 5 - 500	
9	2	" "	" " - 460	
8	2	" "	" " - 540	
7	2	" "	" " - 1110	
6	2	" "	" " - 1000	
5	1	" "	" " - 590	
4	2	" "	" " - 555	
3	4	" "	" " - 155.5	
2	1	" "	" " - 280	
1	1	" "	" " - 200	

SL. No	No REQD	MATERIAL NAME / SIZE / MEASUREMENTS	REMARKS
--------	---------	-------------------------------------	---------

HEAD CONSTRUCTION - 12 PU 500 - WINDMILL

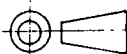
	DESIGNED - BY	DRAWN - BY <i>Pratap</i>	CHECKED - BY <i>Pratap Singh</i>	APPROVED - BY	SCALE N. T. S.
		By. No. 2/94	PRATAP SINGH		

FOR INFORMATION

WIND ENERGY R.-&D. CENTRE
I.E.R.T. ALLAHABAD - 211002-INDIA

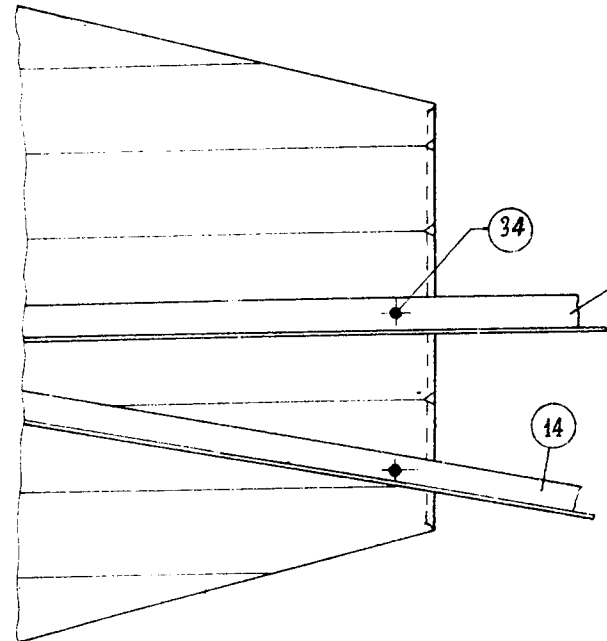
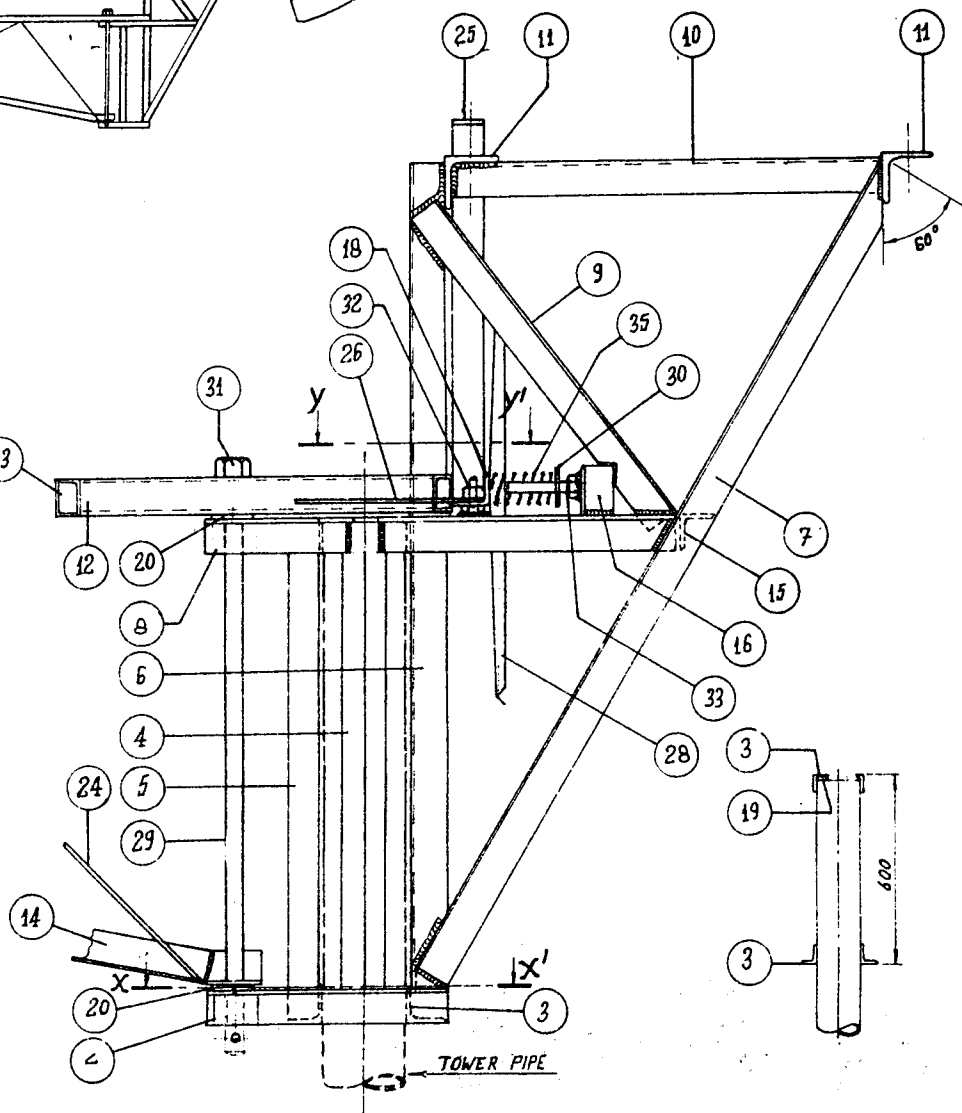
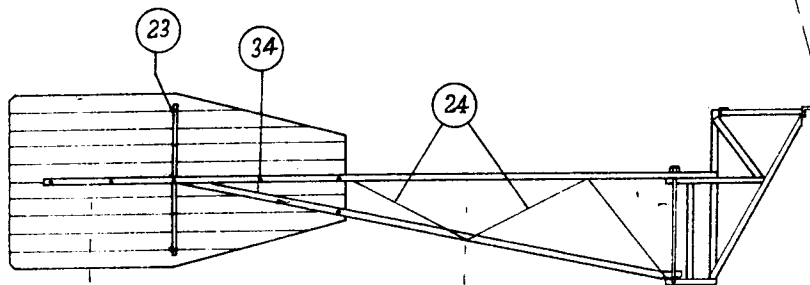
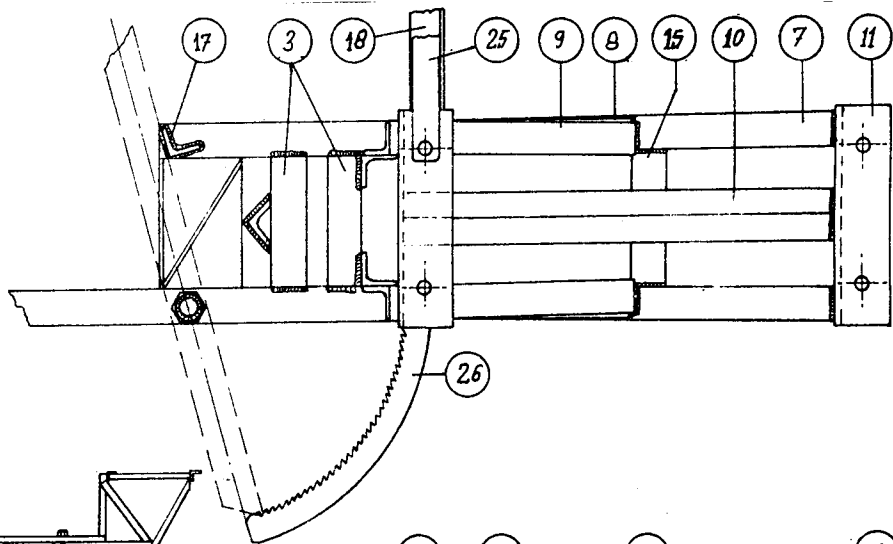

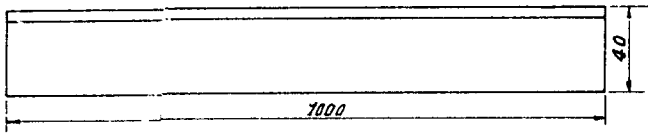

DETAIL ITEM No 6

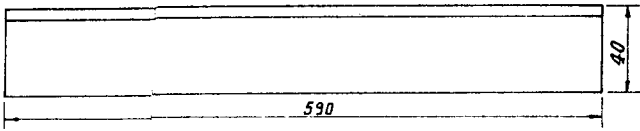
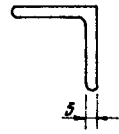

DETAIL ITEM No 5

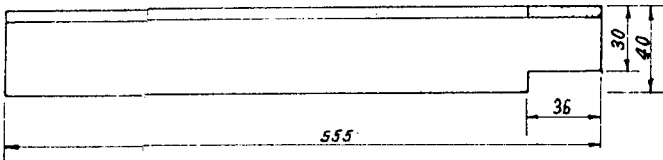
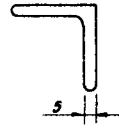

DETAIL ITEM No 4

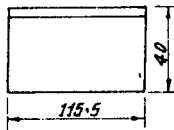
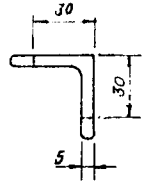

DETAIL ITEM No 3

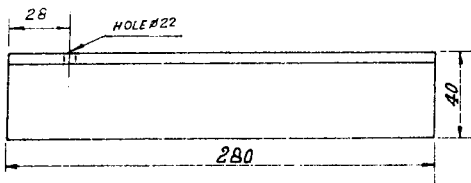
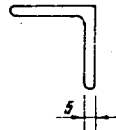

DETAIL ITEM No 2

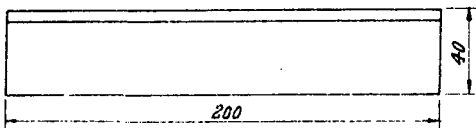
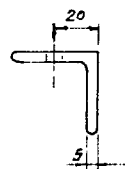

DETAIL ITEM No 1

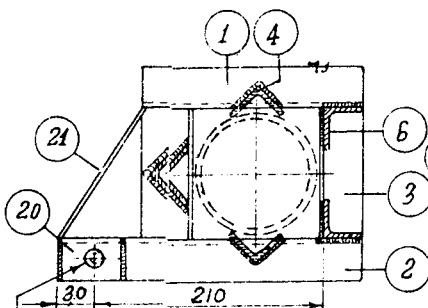
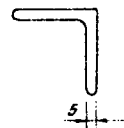

DETAIL SECTION-X X'

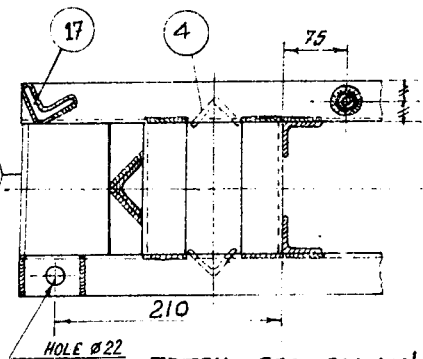

DETAIL SECTION-Y Y'

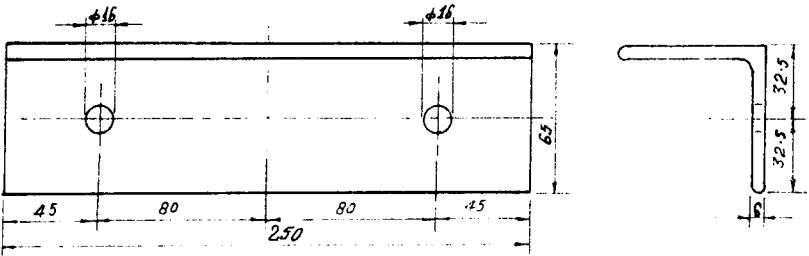

DETAIL ITEM No 11

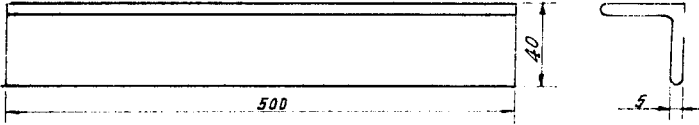

DETAIL ITEM No 10

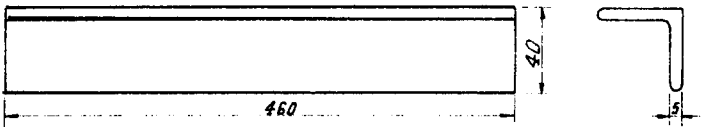

DETAIL ITEM No 9

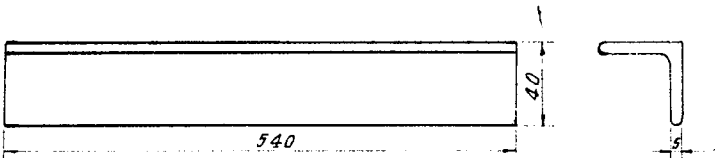

DETAIL ITEM No 8

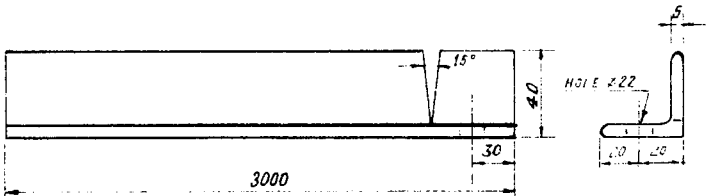

DETAILS ITEM No 14



DETAIL ITEM No 29

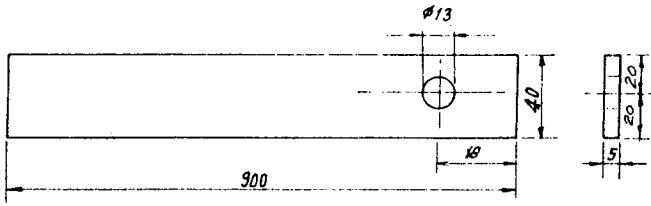
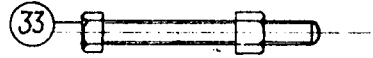

DETAIL ITEM No 25

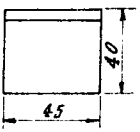

DETAIL ITEM No 17

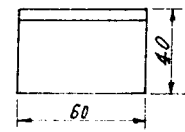
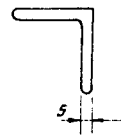

DETAIL ITEM No 16

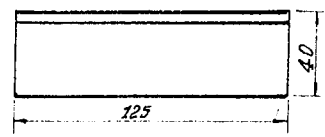
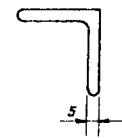

DETAIL ITEM No 15

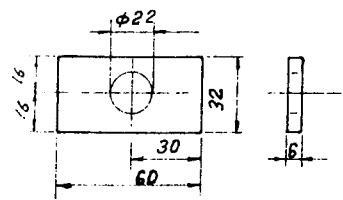
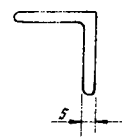

DETAIL ITEM No 20

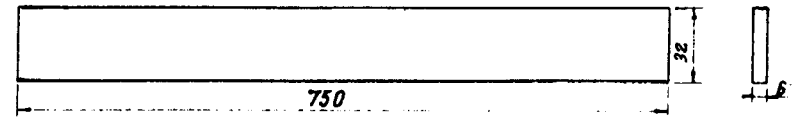

DETAIL ITEM No 24

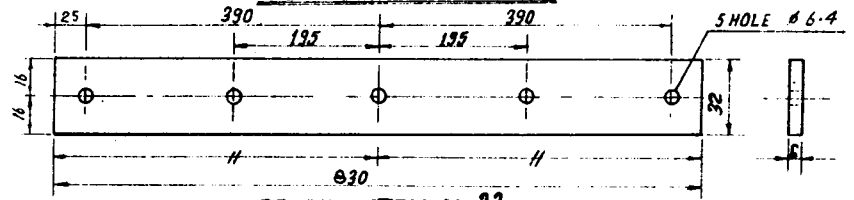

DETAIL ITEM No 23

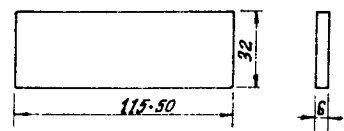

DETAIL ITEM No 22

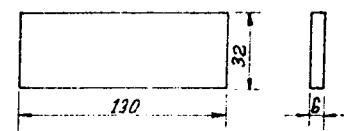

DETAIL ITEM No 21

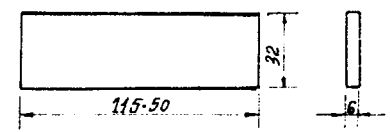

DETAIL ITEM No 19

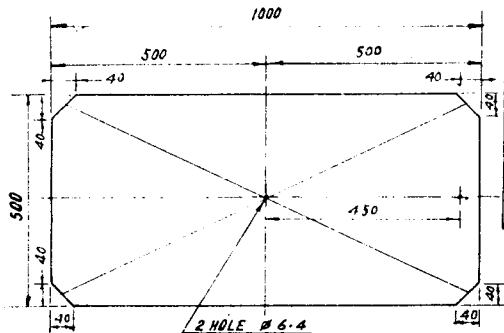

DETAIL ITEM No 28

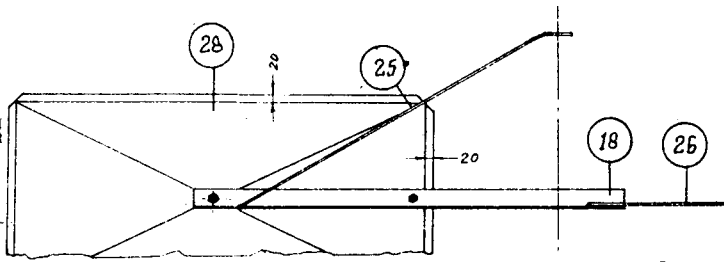

DETAIL ITEM No 18, 25, 26, & 28.

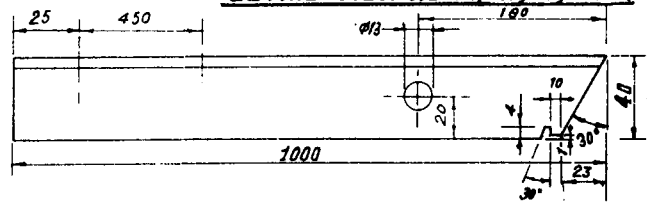

DETAIL ITEM No 18

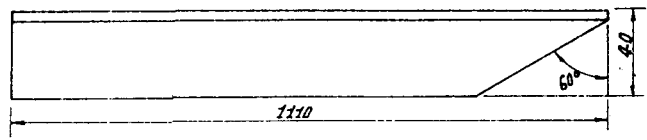
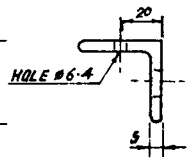

DETAIL ITEM No 7

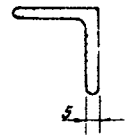

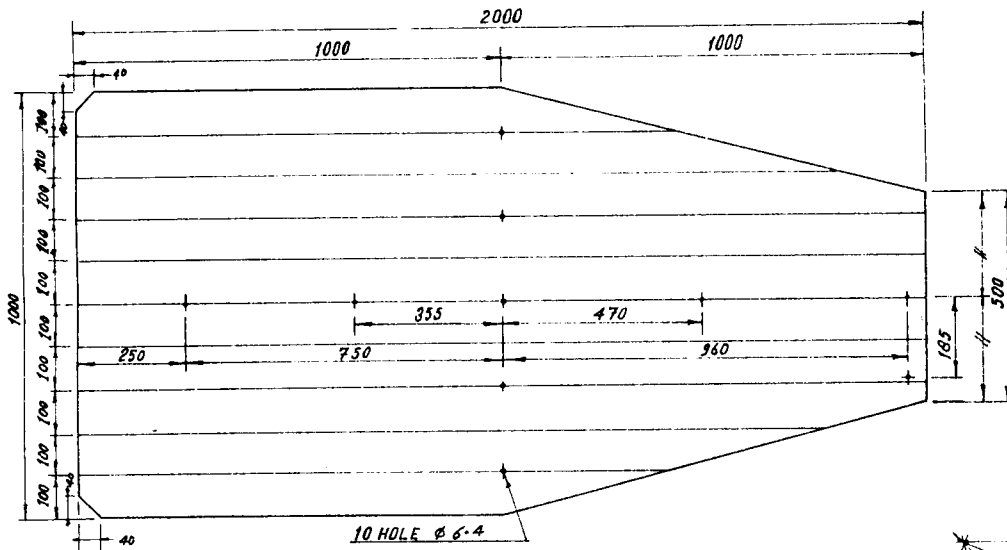

DETAIL ITEM No 27

10 HOLE ϕ 6.4

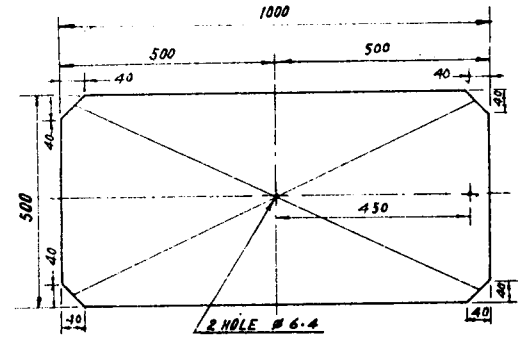

DETAIL ITEM No 28

R HOLE ϕ 6.4

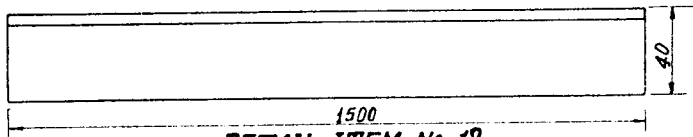

DETAIL ITEM No 12

1500

40

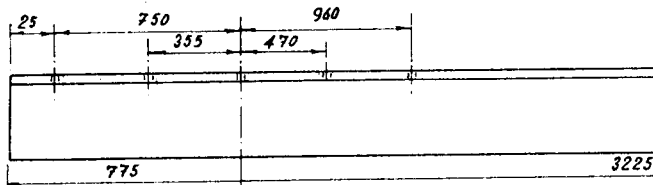

DETAIL ITEM No 13

775

3225

HOLE ϕ 6.4

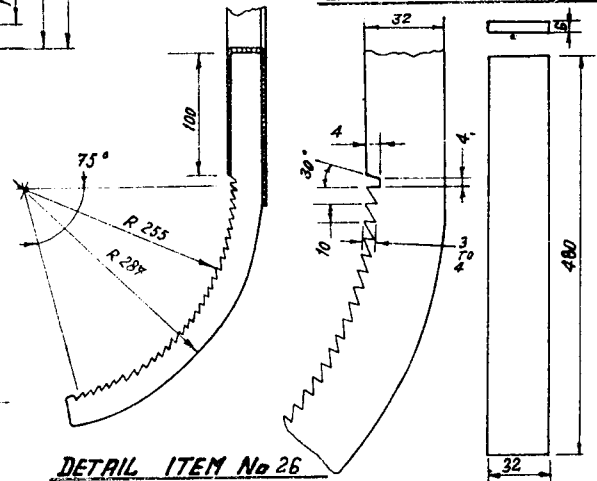

DETAIL ITEM No 26

75°

R 255

R 287

30°

4

4

10

3

4.80

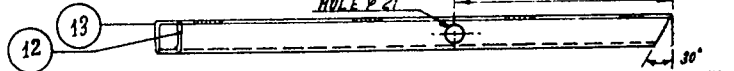

HOLE ϕ 21

255

30°

12

13

* LENGTH DEPEND UPON CIRCUMSTANCES.

21	2	TEAK WOOD PLUMP ROD GLIDE _____	
20	*	G.I. PIPE (B.S.T. MAKE) CLASS 'A' _____	
19	1	GREASE CUP _____	
18	1	FLAT IRON. _____ 25x6 250	
17	2	" " " " _____ 135	
16	1	" " _____ 40x10 165	
15	2	" " _____ 15x6 300	
14	4	" " _____ 30x6 50	
13	1	" " CONNECTING ROD-30x6 650	
12	1	POLYPROPELENE _____ CROSS HEAD.	
11	1	M.S. CROSS PIN. _____ $\phi 25$ 92	
10	2	M.S. BOLT, NUT, WASHER _____ M10x100 (W $\frac{3}{8}$ "x4")	
9	4	M.S. BOLT, NUT, WASHER. _____ M12x50 (W $\frac{1}{2}$ "x2)	
8	1	M.S. NUT. _____ M20 (W $\frac{3}{4}$ "x")	
7	1	M.S. CRANK BOLT (G. K.W MAKE)-M20x75 (W $\frac{3}{4}$ "x3")	
6	1	M.S. WASHER _____ $\phi 20 \times \phi 40 \times 3 \text{mm}$	
5	1	M.S. BUSH _____ $\phi 20 \times \phi 40 \times 44$	
4	4	NYLON BUSH (MOLDED) - $\phi 25 \times \phi 38 \times 18$	
3	2	M.S. BUSH _____ $\phi 33 \times \phi 43 \times 33$	
2	2	PILLOW BLOCK (BEARING) $\phi 50$ C.F.Y.H & NTN P 210J 50mm ± 0.01 BORE	
1	1	M.S. MAIN SHAFT _____ $\phi 50 \times 1300$	

SL. No	N. REQD.	MATERIAL NAME / SIZE / MEASUREMENTS	REMARKS.
--------	----------	-------------------------------------	----------

MOVINGPARTS OF 12 PU 500 WINDMILL

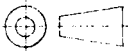
	DESIGNED BY	DRAWN BY <i>Bhavani</i>	CHECKED BY <i>[Signature]</i>	APPROVED BY	SCALE
		TRD. BY <i>[Signature]</i>	PRATAP SINGH		N. T. S.

FOR
INFORMATION

WIND ENERGY R.S.D CENTRE
INSST. OF ENGINEERING AND RURAL TECHNOLOGY
ALLAHABAD - 211002

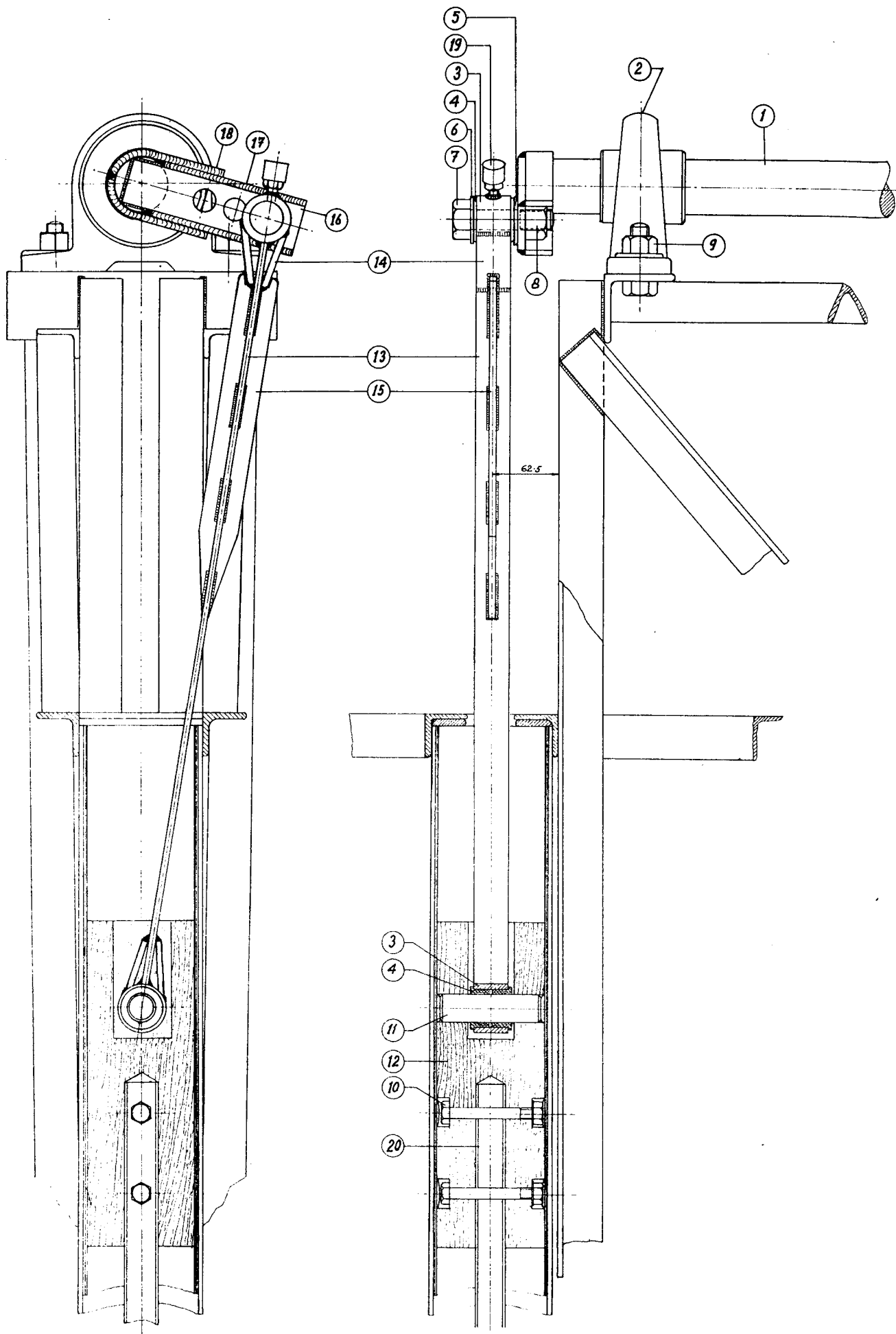

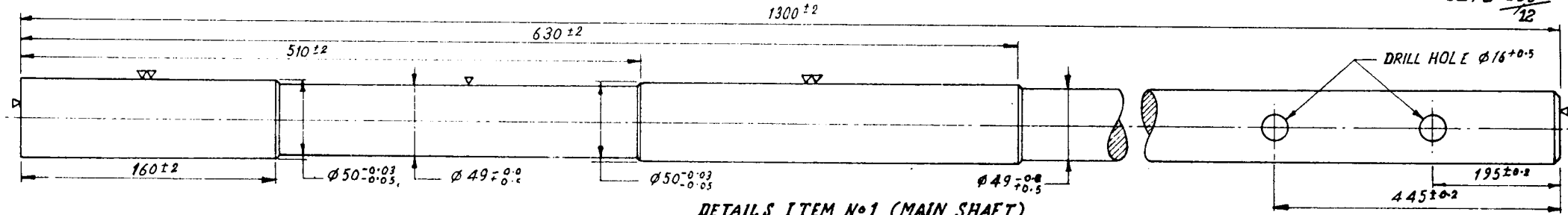

DETAILS ITEM No 1 (MAIN SHAFT)

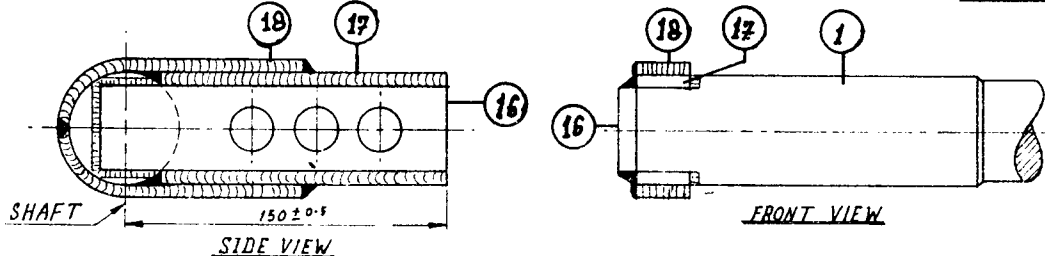

(CRANK) DETAILS ITEM No 16, 17 & 18 WITH SHAFT ASSY. (WELDING)

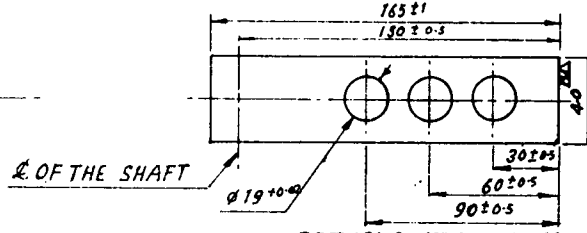

DETAILS ITEM No 16

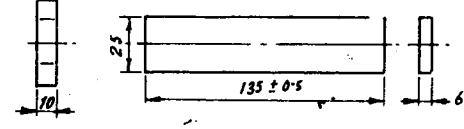

DETAILS ITEM No 17

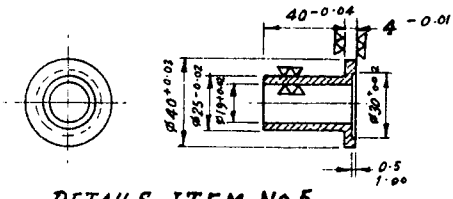

DETAILS ITEM No 5

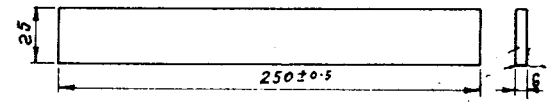

DETAILS ITEM No 18

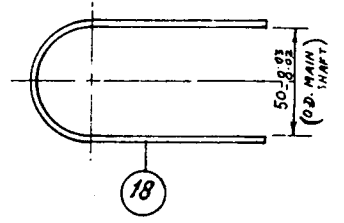

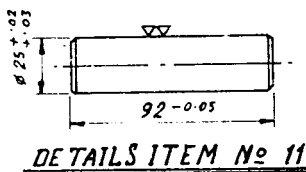
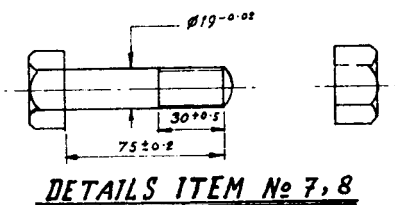
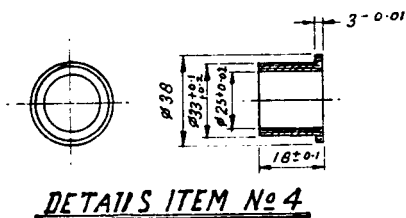
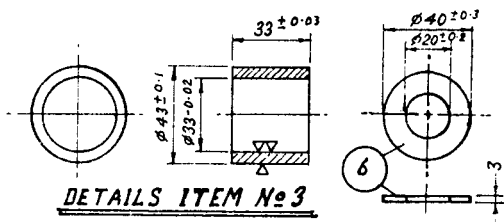

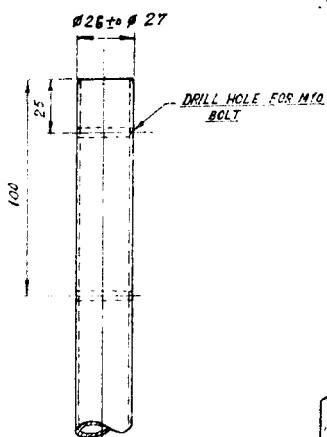

PUMPROD & PISTON ROD
ITEM No 20

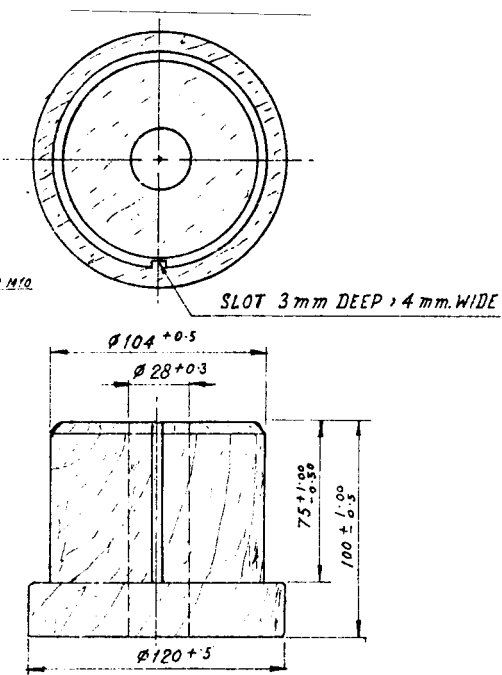

PUMPROD WOODEN GUIDE
(SL.No 42 ON 12 PU 500 PUMP DESIGN)

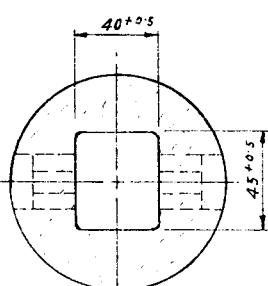

TOP VIEW

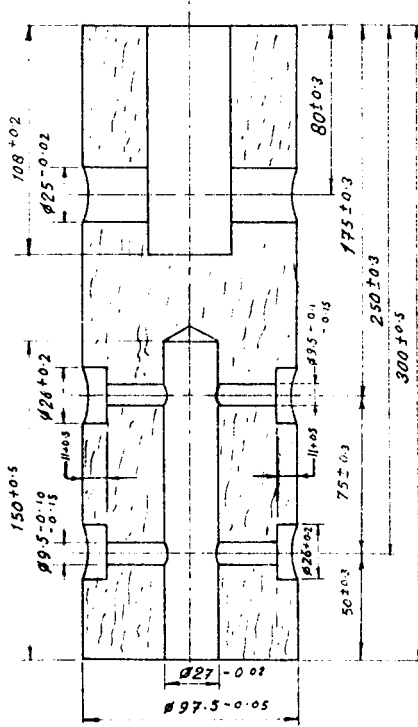

SECTIONAL FRONT VIEW

(CROSSHEAD)- DETAILS ITEM No 12

NOTE :—

* MARKED THUS INDICATES THAT
LENGTH OR QUANTITY WILL VARY
ACCORDING TO CIRCUMSTANCES

36	1	TEAK WOOD / POLYPROPELENE— TEAK WOOD— 5"x5"x4"
35	2	CLAMP ROD $\phi 12$ (1 1/2")X370 mm.
34	1	BOLT, NUT, WASHER M12 X 20 (W 1/2" X 3/4")
33	4	BOLT, NUT, WASHER M12 X 125 (W 1/2" X 5")
32	*	SPRING WASHERS M24 (W 7/8")
31	*	NUTS M24 (W 7/8")
30	*	THREADED STUD M24 X 100 (W 7/8" X 4")
29	1	THREADED STUD M24 X 125 (W 7/8" X 5")
28	*	GUN METAL BUSH $\phi 33$ X 30 mm.
27	*	STEEL BUSH $\phi 43$ X 33 mm.
26	1	PISTON TEAK WOOD / POLYPRDPELENE
25	1	GASKET NITRILE RUBBER / SOLE LEATHER $\phi 290$ X 6 mm
24	2	VALVE $\phi 150$ X 6
23	1	RING ROD $\phi 8$ (3/8")— 870 mm.
22	8	FILLING PIECE ROD $\phi 8$ (3/8")— 40 mm.
21	2	ANGLE IRDN 40 X 40 X 4 (1 1/2" X 1 1/2")— *
20	3	FLAT IRDN 30 X 6 (1 1/4" X 1/4")
19	*	" " " " — 700 mm.
18	1	" " " " — 450 mm.
17	1	" " " " — 180 mm.
16	4	" " " " — 60 mm.
15	12	" " " " — 85 mm.
14	1	FOOT VALVE 3mm. SHEET $\phi 170$ mm.
13	2	CASING 500 X 900 mm.
12	1	CASING FLANGE $\phi 290$ mm.
11	2	CASING FLANGE $\phi 290$ mm.
10	1	CYLINDER SEAMLESS 6" GAS PIPE— 460 mm.
9	1	DELIVERY PIPE 4" " " — 560 mm.
8	*	SOCKET FOR 4" " "
7	1	T- SOCKET " " " "
6	*	DELIVERY PIPE 4" " " — *
5	1	EXHAUST PIPE 4" " " — *
4	1	TOP PIPE 4" " " — 750 mm.
3	4	PIPE 5/8" " " — 100 mm.
2	1	PUMP ROD 3/4" " " — 900 mm.
1	*	PUMP ROD EXTENSION 3/4" " " — *

SL. No. No. REQD. MATERIAL NAME / SIZE / MEASUREMENTS / REMARKS

PISTON PUMP FOR 12 PU 500 WIND MILL

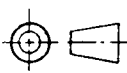
	DRN. BY <i>Biswas</i> (R. K. Tiwari)	TRD. BY <i>Biswas</i> (R. K. Tiwari)	CHD. BY	APPVD. BY	SCALE NTS
---	--	--	---------	-----------	--------------

FOR
INFORMATION

WIND ENERGY R. & D. CENTRE
I. E. R. T. ALLAHABAD - 211002 - INDIA

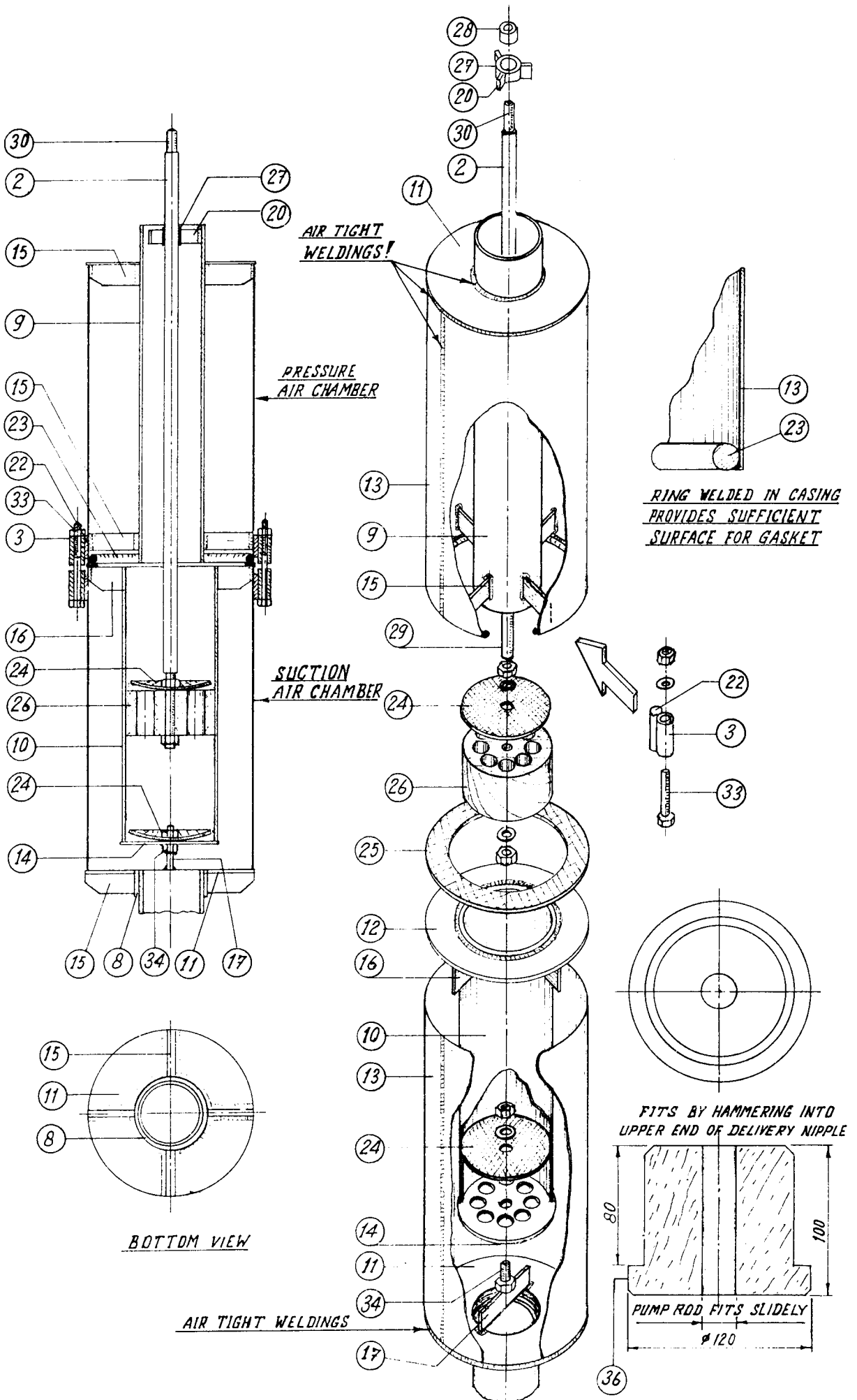

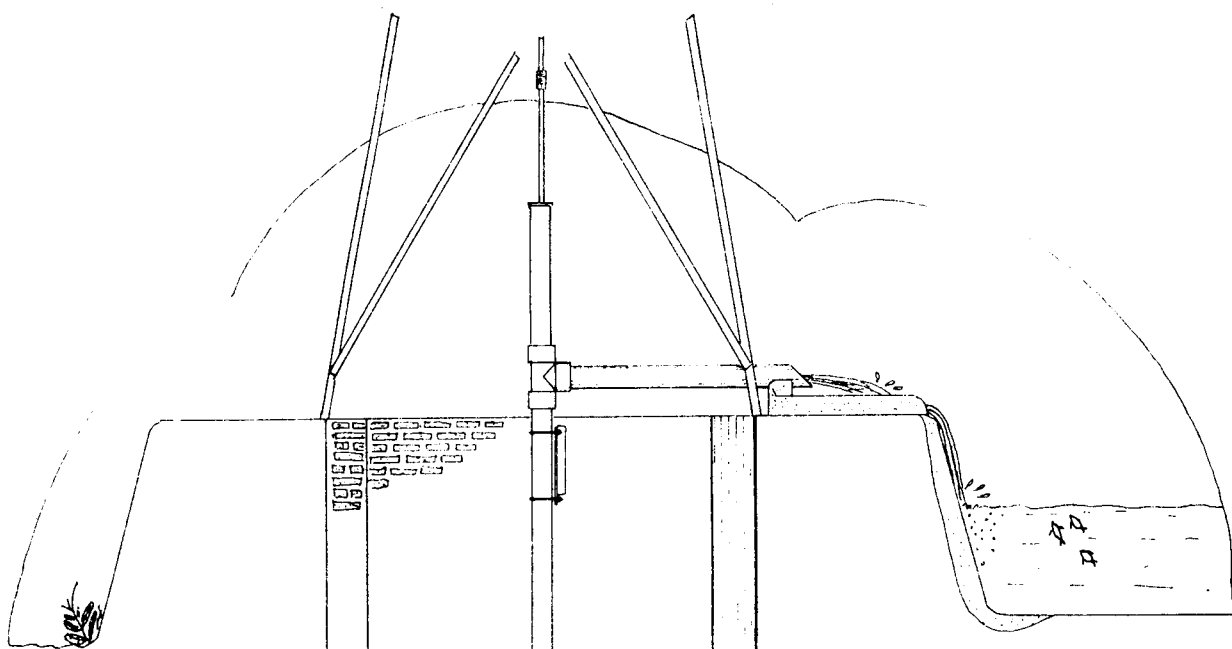

BRICK MASONED WELL

PRESSURE SECTION

SUCTION SECTION

